

Netra t 1120/1125 System Reference Manual



THE NETWORK IS THE COMPUTER™

Sun Microsystems, Inc.
901 San Antonio Road
Palo Alto, CA 94303-4900 USA
650 960-1300 Fax 650 969-9131

Part No. 805-6805-10
Revision A, August 1998

Copyright 1998 Sun Microsystems Computer Company • 901 San Antonio Road • Palo Alto • California 94303 • U.S.A. 415-960-1300 • Fax 415 969-9131. All rights reserved.

This product or document is protected by copyright and distributed under licenses restricting its use, copying, distribution, and decompilation. No part of this product or document may be reproduced in any form by any means without prior written authorization of Sun and its licensors, if any.

Portions of this product may be derived from the UNIX[®] system, licensed from Novell, Inc., and from the Berkeley 4.3 BSD system, licensed from the University of California. UNIX is a registered trademark in the United States and in other countries and is exclusively licensed by X/Open Company Ltd. Third-party software, including font technology in this product, is protected by copyright and licensed from Sun's suppliers. RESTRICTED RIGHTS: Use, duplication, or disclosure by the U.S. Government is subject to restrictions of FAR 52.227-14(g)(2)(6/87) and FAR 52.227-19(6/87), or DFAR 252.227-7015(b)(6/95) and DFAR 227.7202-3(a).

Sun, Sun Microsystems, the Sun logo, Solaris, Netra and the Netra logo are trademarks or registered trademarks of Sun Microsystems, Inc. in the United States and in other countries. All SPARC trademarks are used under license and are trademarks or registered trademarks of SPARC International, Inc. in the United States and in other countries. Products bearing SPARC trademarks are based upon an architecture developed by Sun Microsystems, Inc.

The OPEN LOOK[®] and Sun[™] Graphical User Interfaces were developed by Sun Microsystems, Inc. for its users and licensees. Sun acknowledges the pioneering efforts of Xerox Corporation in researching and developing the concept of visual or graphical user interfaces for the computer industry. Sun holds a nonexclusive license from Xerox to the Xerox Graphical User Interface, which license also covers Sun's licensees who implement OPEN LOOK GUIs and otherwise comply with Sun's written license agreements.

THIS PUBLICATION IS PROVIDED "AS IS" WITHOUT WARRANTY OF ANY KIND, EITHER EXPRESS OR IMPLIED, INCLUDING, BUT NOT LIMITED TO, THE IMPLIED WARRANTIES OF MERCHANTABILITY, FITNESS FOR A PARTICULAR PURPOSE, OR NON-INFRINGEMENT.

Copyright 1998 Sun Microsystems Computer Company • 901 San Antonio Road • Palo Alto • California 94303 U.S.A. • 415-960-1300 • Fax 415 969-9131. Tous droits réservés.

Ce produit ou document est protégé par un copyright et distribué avec des licences qui en restreignent l'utilisation, la copie et la décompilation. Aucune partie de ce produit ou de sa documentation associée ne peut être reproduite sous aucune forme, par quelque moyen que ce soit, sans l'autorisation préalable et écrite de Sun et de ses bailleurs de licence, s'il y en a.

Des parties de ce produit pourront être dérivées du système UNIX[®] licencié par Novell, Inc. et du système Berkeley 4.3 BSD licencié par l'Université de Californie. UNIX est une marque enregistrée aux Etats-Unis et dans d'autres pays, et licenciée exclusivement par X/Open Company Ltd. Le logiciel détenu par des tiers, et qui comprend la technologie relative aux polices de caractères, est protégé par un copyright et licencié par des fournisseurs de Sun.

Sun, Sun Microsystems, le logo Sun, Solaris, Netra et le logo Netra sont des marques déposées ou enregistrées de Sun Microsystems, Inc. aux Etats-Unis et dans d'autres pays. Toutes les marques SPARC, utilisées sous licence, sont des marques déposées ou enregistrées de SPARC International, Inc. aux Etats-Unis et dans d'autres pays. Les produits portant les marques SPARC sont basés sur une architecture développée par Sun Microsystems, Inc.

Les utilisateurs d'interfaces graphiques OPEN LOOK[®] et Sun[™] ont été développés de Sun Microsystems, Inc. pour ses utilisateurs et licenciés. Sun reconnaît les efforts de pionniers de Xerox Corporation pour la recherche et le développement du concept des interfaces d'utilisation visuelle ou graphique pour l'industrie de l'informatique. Sun détient une licence non exclusive de Xerox sur l'interface d'utilisation graphique, cette licence couvrant aussi les licenciés de Sun qui mettent en place les utilisateurs d'interfaces graphiques OPEN LOOK et qui en outre se conforment aux licences écrites de Sun.

CETTE PUBLICATION EST FOURNIE "EN L'ETAT" SANS GARANTIE D'AUCUNE SORTE, NI EXPRESSE NI IMPLICITE, Y COMPRIS, ET SANS QUE CETTE LISTE NE SOIT LIMITATIVE, DES GARANTIES CONCERNANT LA VALEUR MARCHANDE, L'APTITUDE DES PRODUITS A REpondre A UNE UTILISATION PARTICULIERE OU LE FAIT QU'ILS NE SOIENT PAS CONTREFAISANTS DE PRODUITS DE TIERS.



Contents

Figures vii

Tables ix

Preface xi

- 1. Product Overview** 1-1
 - 1.1 System Features 1-2
 - 1.2 To Power On the System 1-5
 - 1.3 To Power Off the System 1-6
 - 1.4 To Attach the Wrist Strap 1-7
 - 1.5 To Remove the Top Access Cover 1-10
 - 1.6 To Replace the Top Access Cover 1-12

- 2. Back Panel Connectors** 2-1
 - 2.1 Connector Layout 2-1
 - 2.2 Serial Connectors 2-2
 - 2.3 Media Independent Interface (MII) Connector 2-3
 - 2.3.1 Cable-Type Connectivity 2-4
 - 2.3.2 External Cable Length 2-4
 - 2.4 Twisted-Pair Ethernet (TPE) Connector 2-5
 - 2.4.1 TPE Cable-Type Connectivity 2-5

- 2.5 SCSI Connector 2-6
 - 2.5.1 SCSI Implementation 2-7
 - 2.5.2 SCSI Cabling and Configuration 2-8
 - 2.5.2.1 SCSI Cabling Procedure 2-8
 - 2.5.2.2 SCSI-2 (Fast Wide SCSI) External Devices 2-9
- 2.6 Alarms Port 2-10
 - 2.6.1 Alarm Output Description 2-10
- 2.7 Parallel Interface 2-11

- 3. Twisted-Pair Ethernet Link Test 3-1**
 - 3.1 Overview 3-1
 - 3.2 Technical Discussion 3-4
 - 3.3 Troubleshooting 3-4
 - 3.4 Moves and Changes 3-5
 - 3.5 To Check or Disable the Link Test 3-5
 - 3.6 To Enable the Link Test 3-6

- 4. Modem Setup 4-1**
 - 4.1 To Set Up the Modem 4-1
 - 4.2 Serial Port Speed Change 4-2
 - 4.3 Recommendations 4-2

- 5. Main Logic Board Jumpers 5-1**
 - 5.1 To Identify Jumpers 5-2
 - 5.2 Flash PROM Jumpers 5-3
 - 5.3 Serial Port Jumpers 5-3

- A. Functional Description A-1**
 - A.1 System A-1
 - A.2 UPA A-3
 - A.3 PCI Bus A-4
 - A.3.1 U2P ASIC A-4

- A.3.2 Symbios 53C876 SCSI Controller A-5
- A.3.3 PCIO ASIC A-5
- A.4 UltraSPARC II Processor A-5
- A.5 Memory System A-6
 - A.5.1 SIMM A-9
 - A.5.1.1 Memory System Timing A-10
- A.6 Peripherals A-12
 - A.6.1 Disk Drives A-12
 - A.6.2 Optional CD-ROM Drive A-12
 - A.6.3 Optional 2.5Gbyte, 4mm and 8mm Tape Drives A-13
 - A.6.3.1 2.5Gbyte Tape Drive A-13
 - A.6.3.2 4mm Tape Drive A-13
 - A.6.3.3 8mm Tape Drive A-13
- A.7 Parallel Port A-14
 - A.7.1 Parallel Port Cables A-14
 - A.7.2 Electrical Characteristics A-14
- A.8 Serial Port A-15
 - A.8.1 Serial Port Components A-16
 - A.8.2 Serial Port Functions A-16
 - A.8.3 EIA Levels A-16
 - A.8.3.1 Synchronous Rates A-17
 - A.8.3.2 Asynchronous Rates A-17
 - A.8.3.3 Slew Rate and Cable Length A-17
- A.9 Ethernet A-17
 - A.9.1 Automatic Negotiation A-18
 - A.9.2 External Transceivers A-19
 - A.9.3 External Cables A-19
 - A.9.4 Connectors A-19
 - A.9.5 MII Power A-19
 - A.9.6 MII Port Timing A-20

A.10 Alarms Card	A-21
A.11 Ebus Connector	A-22
A.12 SCSI	A-23
A.12.1 Host Adapter	A-24
A.12.2 Supported Target Devices	A-24
A.12.3 External Cables	A-25
A.12.4 Internal SCSI Subassembly	A-25
A.12.5 SCSI ID Selection	A-27
A.13 ASICs	A-27
A.13.1 QSC	A-27
A.13.2 XB9+	A-28
A.13.3 PCIO	A-28
A.13.4 U2P	A-28
A.13.5 RISC	A-29
A.13.6 SuperIO	A-29
A.14 Power Supply	A-30
A.14.1 Netra t 1120	A-30
A.14.2 Netra t 1125	A-31

Index	Index-1
-------	---------

Figures

- FIGURE 1-1 Netra t 1120 System Front View 1-3
- FIGURE 1-2 Netra t 1125 System Front View 1-3
- FIGURE 1-3 Netra t 1120 System Rear View 1-4
- FIGURE 1-4 Netra t 1125 System Rear View 1-4
- FIGURE 1-5 System Power-On (Front Panel) 1-5
- FIGURE 1-6 System Power-Off (Front Panel) 1-7
- FIGURE 1-7 Attaching the Wrist Strap to the Front of the Chassis 1-8
- FIGURE 1-8 Attaching the Wrist Strap to the Rear of the Chassis 1-9
- FIGURE 1-9 Removing the Top Access Cover 1-11
- FIGURE 1-10 Replacing the Top Access Cover 1-13
- FIGURE 2-1 Back Panel Connectors 2-1
- FIGURE 2-2 DB-25 Serial Connectors 2-2
- FIGURE 2-3 40-Pin Miniature-D MII Connector 2-3
- FIGURE 2-4 RJ45 TPE Socket 2-5
- FIGURE 2-5 68-Pin SCSI Connector 2-6
- FIGURE 2-6 Connecting External Mass Storage Devices 2-9
- FIGURE 2-7 Alarms Connector Configuration 2-10
- FIGURE 2-8 Dry Contact Outputs 2-10
- FIGURE 2-9 DB-25 Parallel Connector 2-11

- FIGURE 3-1 Hosts and Hub in a Local Area Network 3-2
- FIGURE 3-2 Ensuring Host Hub Communication in a 10BASE-T Network 3-3
- FIGURE 5-1 Jumper Locations on the Main Logic Board 5-1
- FIGURE 5-2 To Identify Jumper Pins 5-2
- FIGURE A-1 System Unit Functional Block Diagram A-2
- FIGURE A-2 UPA Address and Data Buses Functional Block Diagram A-4
- FIGURE A-3 Memory System Functional Block Diagram A-6
- FIGURE A-4 SIMM Mapping A-7
- FIGURE A-5 Memory Module Functional Block Diagram A-8
- FIGURE A-6 120MHz (8.33ns) Timing – Two Reads to the Same Bank A-10
- FIGURE A-7 120MHz (8.33ns) Timing – Two Writes to the Same Bank A-10
- FIGURE A-8 120MHz (8.33ns) Timing – Read/Write to Same Bank A-11
- FIGURE A-9 120 MHz (8.33ns) Timing – Write/Read to Same Bank A-11
- FIGURE A-10 120 MHz (8.33ns) Timing – Refresh Cycle A-11
- FIGURE A-11 Serial Port Functional Block Diagram A-15
- FIGURE A-12 MII Port Timing Model A-20
- FIGURE A-13 Alarms Card Functional Block Diagram A-21
- FIGURE A-14 Configuration for the SCSI Bus A-23
- FIGURE A-15 SCSI Sub-Assembly Block Diagram A-26

Tables

TABLE 2-1	Serial Connector Pinouts, RS423/RS232	2-2
TABLE 2-2	Connector Pinouts	2-3
TABLE 2-3	MII External Cable Lengths	2-4
TABLE 2-5	TPE STP-5 Cable Lengths	2-5
TABLE 2-4	TPE Connector Pinouts	2-5
TABLE 2-6	68-Pin SCSI Connector Pinouts	2-6
TABLE 2-7	Determining SCSI Bus Length	2-8
TABLE 2-8	Alarms Connector Line Assignments	2-10
TABLE 2-9	Parallel Connector Pinouts	2-11
TABLE 5-1	User-Configurable Jumpers	5-2
TABLE 5-2	Flash PROM Jumper Settings	5-3
TABLE 5-3	Serial Port Jumper Settings	5-3
TABLE A-1	UPA Port Identification Assignments	A-3
TABLE A-2	DIMM Bank-to-U-Number Mapping	A-9
TABLE A-3	IL = 0, DIMM Bank-to-Physical Address Mapping	A-9
TABLE A-4	Supported Disk Drives	A-12
TABLE A-5	Ebus Connector Pinouts	A-22
TABLE A-6	SCSI Devices Supported	A-24
TABLE A-7	DC Power Supply Output Voltages	A-30
TABLE A-8	AC Power Supply Output Voltages	A-31

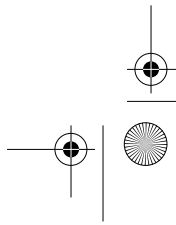
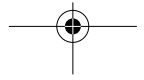
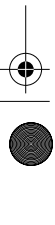
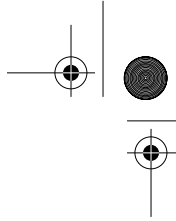

Preface

The *Netra t 1120/1125 System Reference Manual* provides information on the configuration of the subsystems in the Netra t 1120 (order code N04) and Netra t 1125 (order code N03).

Note – This Guide does not apply to the version of Netra t 1120 supplied as order code N02.

Note – All illustrations in this manual are of the Netra t 1125, except where the two types of system differ, in which case examples of both are shown.

Who Should Use This Guide

This manual is intended to be read by OEM engineers, system designers and application programmers who have to perform advanced tasks concerned with the maintenance and configuration of the system.

How This Guide Is Organized

The guide is arranged as follows:

Chapter 1, “Product Overview”, describes the key features of the Netra t 1120/1125 system.

Chapter 2, “Back Panel Connectors”, provides information on the Netra t 1120/1125 system board and its components.

Chapter 3, “Twisted-Pair Ethernet Link Test”, describes how to connect your Netra t 1120/1125 system to a 10BASE-T Twisted-Pair Ethernet (TPE) network.

Chapter 4, “Modem Setup”, provides information on modem setup specifications. Any modem compatible with CCITT V.24 can be connected to the Netra t 1120/1125 serial ports.

Chapter 5, “Main Logic Board Jumpers”, provides information about the main logic board jumpers.

Appendix A, “Functional Description”, is a functional description of the Netra t 1120/1125 system.

Accompanying Documentation

- Netra t 1120/1125 Compliance and Safety Manual (805-6806-10)

Note – It is important that you read the *Netra t 1120/1125 Compliance and Safety Manual* before doing anything else.

- Netra t 1120/1125 Installation and Basic Maintenance Guide (805-6803-10)
- Netra t 1120/1125 Service Manual (805-6804-10)
- Netra t 1120/1125 User’s Guide (805-6040-05)

Conventions used in this Guide

The following table shows the type changes and symbols used in this guide.

TABLE P-1 Typographic Conventions

Typeface or Symbol	Meaning	Example
AaBbCc123	The names of commands, files, and directories; on-screen computer output	Edit your <code>.login</code> file. Use <code>ls -a</code> to list all files. system% You have mail.
AaBbCc123	What you type, as opposed to on-screen computer output	system% su Password:
<i>AaBbCc123</i>	Command-line placeholder: replace with a real name or value	To delete a file, type <code>rm filename</code> .
<i>AaBbCc123</i>	Book titles, new words or terms, or words to be emphasized	Read Chapter 6 in <i>User's Guide</i> . These are called <i>class</i> options. You <i>must</i> be root to do this.
%	UNIX C shell prompt	system%
\$	UNIX Bourne and Korn shell prompt	system\$
#	super-user prompt, all shells	system#

Symbols

The following symbols mean:

Note – A note provides information which should be considered by the reader.



Caution – Cautions accompanied by this Attention icon carry information about procedures or events which if not considered may cause damage to the data or hardware of your system.



Caution – Cautions accompanied by this Hazard icon carry information about procedures which must be followed to reduce the risk of electric shock and danger to personal health. Follow all instructions carefully.

1125

Paragraphs accompanied by this 1125 icon apply only to Netra t 1125 systems.

1120

Paragraphs accompanied by this 1120 icon apply only to Netra t 1120 systems.

CHAPTER 1

Product Overview

The Netra t 1120/1125 system is a multi-processor device that uses the family of UltraSPARC™ II processors. Housed within a rack-mounting enclosure, the Netra t 1120/1125 provides the following:

- One or two UltraSPARC II processors
- Increased power and cooling for high performance processors
- Extensive I/O expansion and a wide range of options
- Modular internal design
- High performance disk, system, memory and I/O subsystem
- High-performance peripheral component interconnect (PCI) I/O expansion with comparable options to existing SBus options.

The Netra t 1120 is a $-48V/-60V$ dc-powered system. The Netra t 1125 is powered by a standard AC mains supply. There are no other differences between the systems.

FIGURE 1-1 and FIGURE 1-2 on page 1-3 and FIGURE 1-3 and FIGURE 1-4 on page 1-4 show the Netra t 1120/1125 system. The following sections provide a brief description of the Netra t 1120/1125 I/O devices and a detailed overview of the system's features.

1.1 System Features

System components are housed in a rack-mounting enclosure. Overall enclosure dimensions (width x depth x height) are 431.8mm x 496.1mm x 177mm (17.13in x 19.53in x 7in (4U)). System electronics are contained on a single printed circuit board (motherboard). The motherboard contains the CPU module(s), memory, system control application-specific integrated circuits (ASICs), and I/O ASICs.

The system unit has the following features:

- Rack-mountable enclosure with power supply.
- Support for up to two modular UltraSPARC II processor(s) with 1, 2 or 4 Mbyte Ecache, at operating frequencies from 300MHz to 400MHz.
- UPA coherent memory interconnect.
- Use of SIMMs, with an interleaved memory system. Each pair of SIMM slots (four rows of two pairs each) accepts 32, 64, or 128Mbyte SIMM modules. Populating with two pairs of identical capacity SIMMs enables the memory controller to interleave and overlap, providing optimal system performance. There are a total of 16 SIMM slots.
- Four PCI slots:
 - Three 33MHz, 64- or 32-bit, 5Vdc slots.
 - One 66MHz or 33MHz, 64- or 32-bit, 3.3Vdc slot.

Universal PCI cards can be used in any of the four PCI slots.

- 10/100Mbps Ethernet.
- 40Mb/s UltraSCSI (Fast-20).
- Two DB-25 serial ports (synchronous and asynchronous protocols).
- One parallel port.

FIGURE 1-2 and FIGURE 1-2 show the system unit front view. FIGURE 1-4 and FIGURE 1-4 shows the system unit rear view.

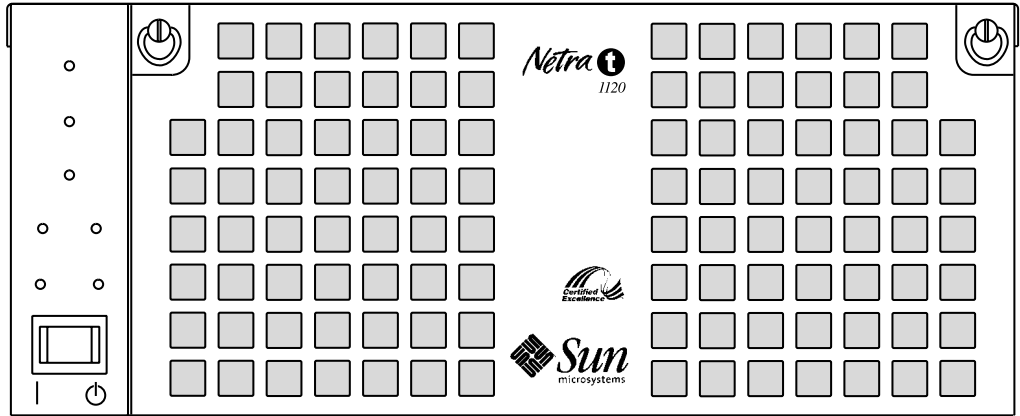

FIGURE 1-1 Netra t 1120 System Front View

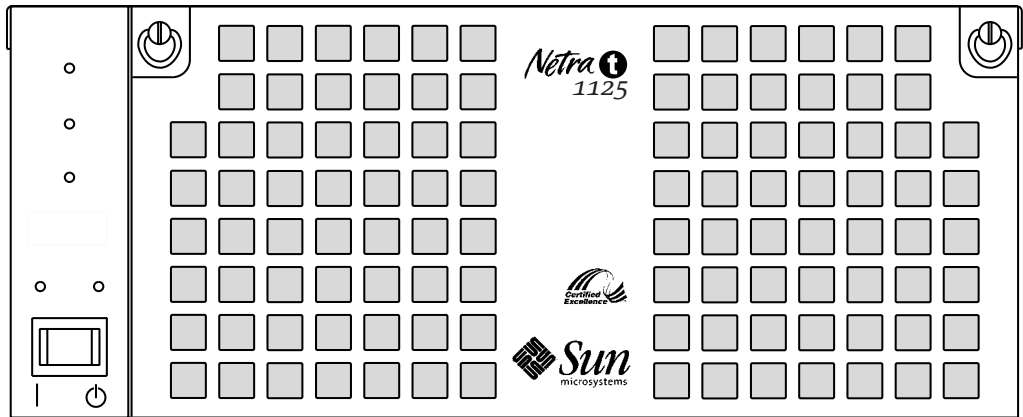

FIGURE 1-2 Netra t 1125 System Front View

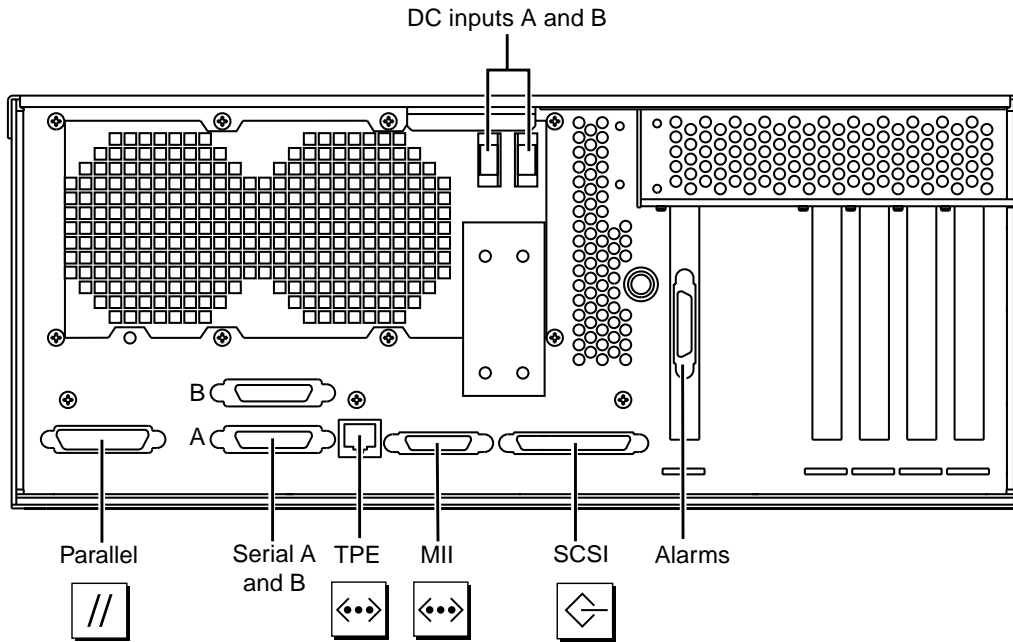

FIGURE 1-3 Netra t 1120 System Rear View

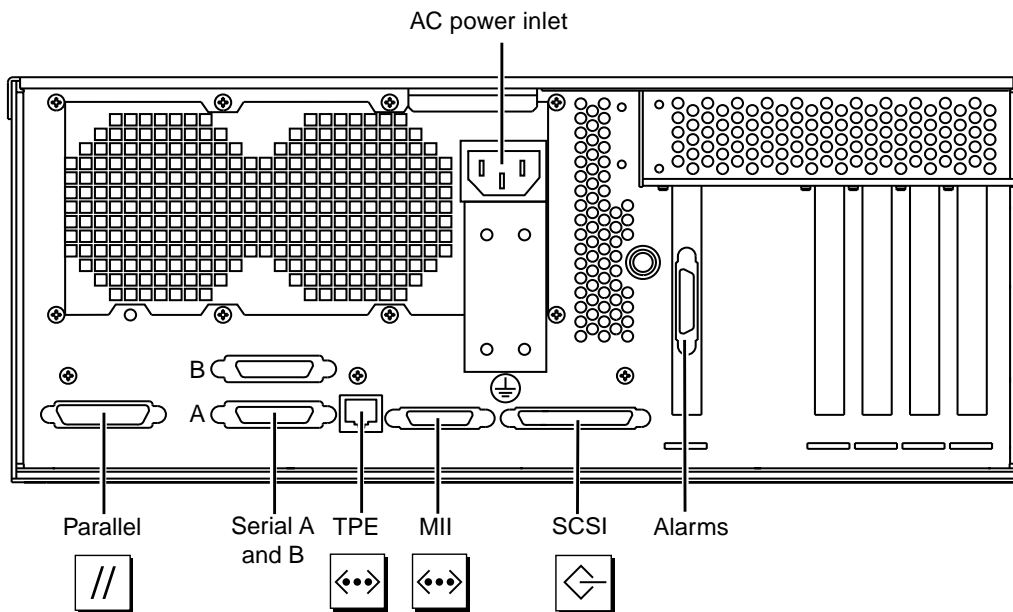

FIGURE 1-4 Netra t 1125 System Rear View

1.2 To Power On the System

1. Prior to powering on, inspect the supply connector(s) for correct polarity and mechanical security.

1125

2. Apply power to the system power inlet, or

1120

activate the external circuit breakers for input A and input B.

3. Momentarily set the front panel ON/STBY system switch to the ON | position and hold it until the system starts to power up.

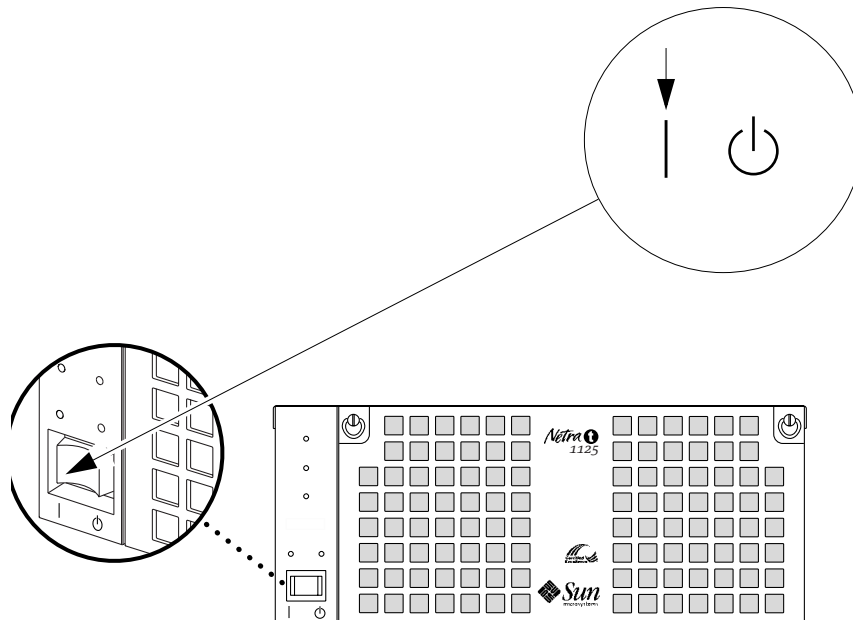



FIGURE 1-5 System Power-On (Front Panel)

1.3 To Power Off the System



Caution – Prior to turning off system power, exit from the operating system. Failure to do so may result in data loss.

1. Where necessary, notify the users that the system is going down.
2. Back up system files and data.
3. Halt the operating system.
4. Momentarily set the front panel ON/STBY system switch to the STBY  position until the system powers down.
5. Verify that the Power LED is off.
6. Disconnect the input power connector(s) from the unit, or open the circuit breaker(s) associated with the unit.



1125

Caution – Regardless of the position of the ON/STBY switch, where an AC power cord remains connected to the system, hazardous voltages are always present within the power supply.

1120

Regardless of the position of the ON/STBY switch, where a DC power cord remains connected to the system, DC voltage is always present within the power supply.

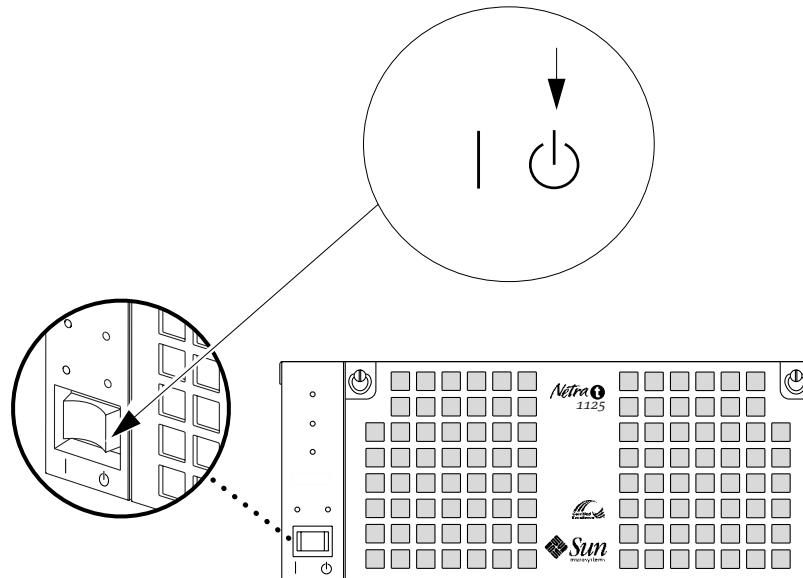

FIGURE 1-6 System Power-Off (Front Panel)

1.4 To Attach the Wrist Strap



Caution – Wear an antistatic wrist strap and use an ESD-protected mat when handling components. When servicing or removing system unit components, use a wrist strap with a 10mm press stud connection and attach the wrist strap to the press stud at the front or rear of the chassis. This should be performed before the top cover is removed.

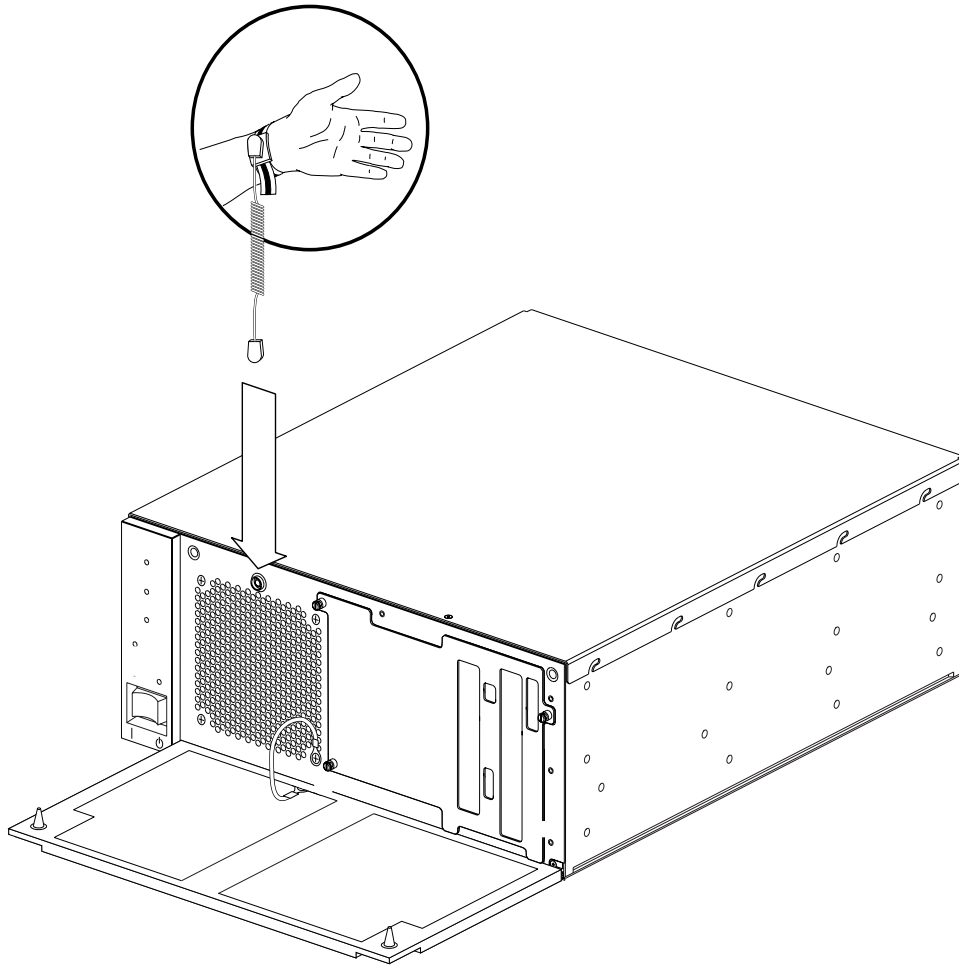

FIGURE 1-7 Attaching the Wrist Strap to the Front of the Chassis

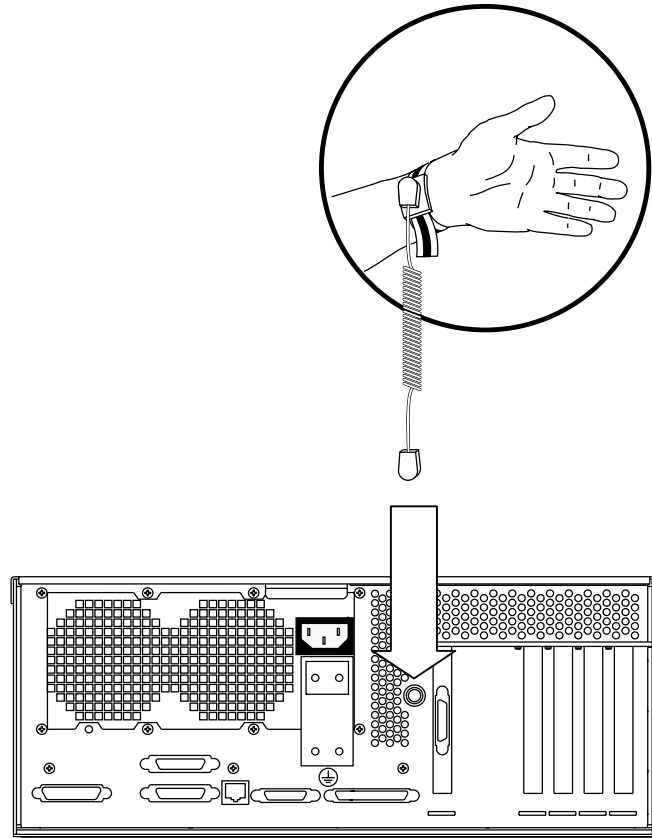

FIGURE 1-8 Attaching the Wrist Strap to the Rear of the Chassis

1.5 To Remove the Top Access Cover

Note – This operation should be performed by qualified personnel only.

1. Power off the system.

See Section 1.3 “To Power Off the System” on page 1-6.



Caution – Wear an antistatic wrist strap and use an ESD-protected mat when handling components. When servicing or removing system unit components, an ESD Strap should be attached to the wrist, then to one of the connection points provided on the system, and then the power connectors should be removed from the system unit. Following this caution equalizes all electrical potentials with the system unit.

2. Disconnect the input power connector(s) from the rear of the unit or open the associated circuit breaker(s), if fitted.

3. Attach the wrist strap.

See Section 1.4 “To Attach the Wrist Strap” on page 1-7.

4. Remove the rack fixing screws and withdraw the unit on its slides (if fitted). Refer to FIGURE 1-9 on page 1-11.

To remove the top access cover, the unit may need to be completely removed from the rack. If slides are fitted, disconnect the cables and release the slides. Place the system on an approved work station/position.

5. Remove the two screws from the front of the top access cover and carefully store them away from the system unit.

6. Place the system so that the extended tab of the top access cover is facing you. To release the top cover, pull the tab towards you and lift the cover off.

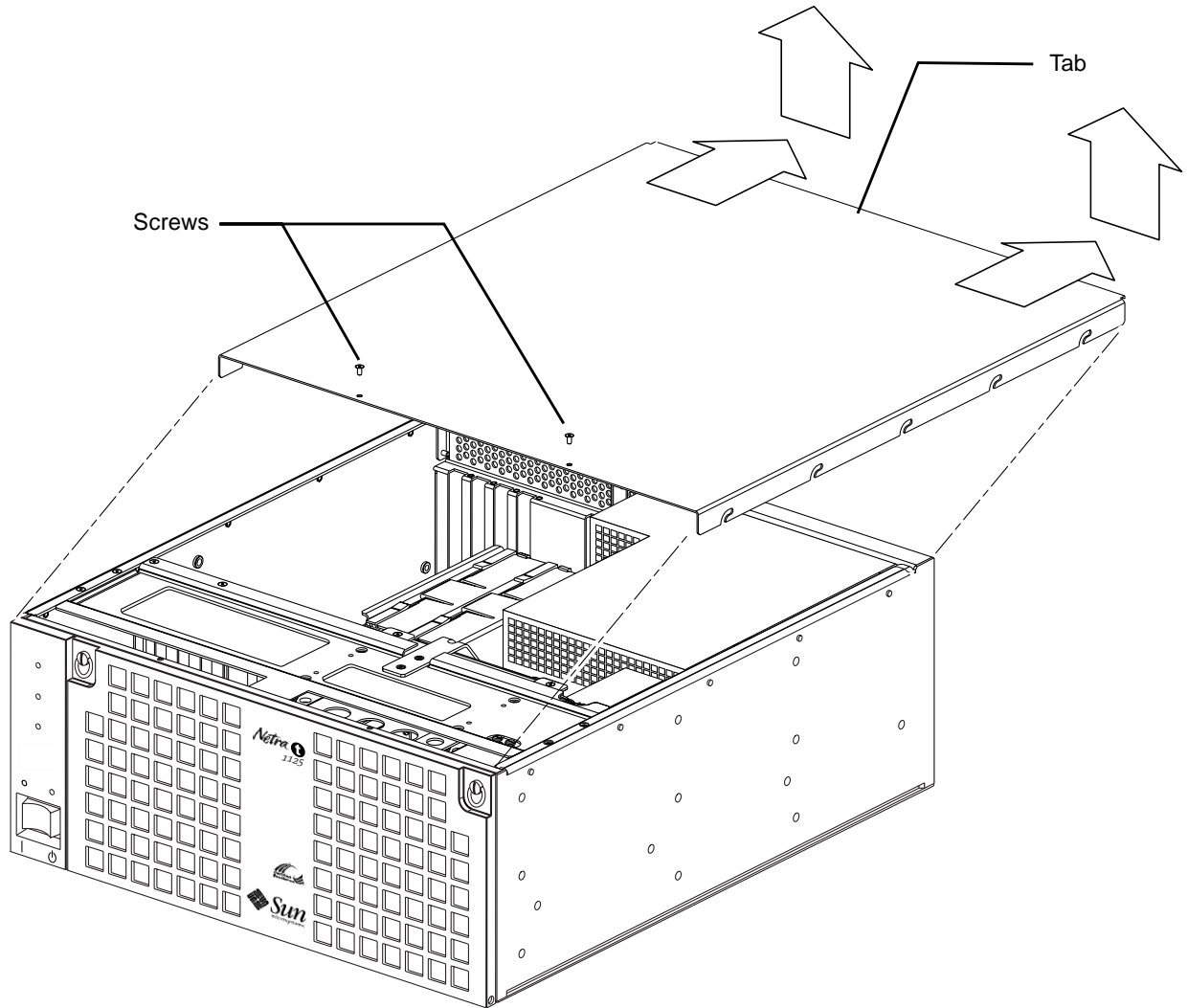

FIGURE 1-9 Removing the Top Access Cover

1.6 To Replace the Top Access Cover



Caution – Wear an antistatic wrist strap and use an ESD-protected mat when handling components. When servicing or removing system unit components, an ESD Strap should be attached to the wrist, then to one of the connection points provided on the system, and then the power connectors should be removed from the system unit. Following this caution equalizes all electrical potentials with the system unit.

- 1. Attach the wrist strap.**
See Section 1.4 “To Attach the Wrist Strap” on page 1-7.
- 2. Position the top access cover.**
See FIGURE 1-10 on page 1-13.
- 3. Engage the top access cover. Push the top cover forwards until the lugs on the sides have fully engaged in the slots.**
- 4. Replace the two fixing screws.**

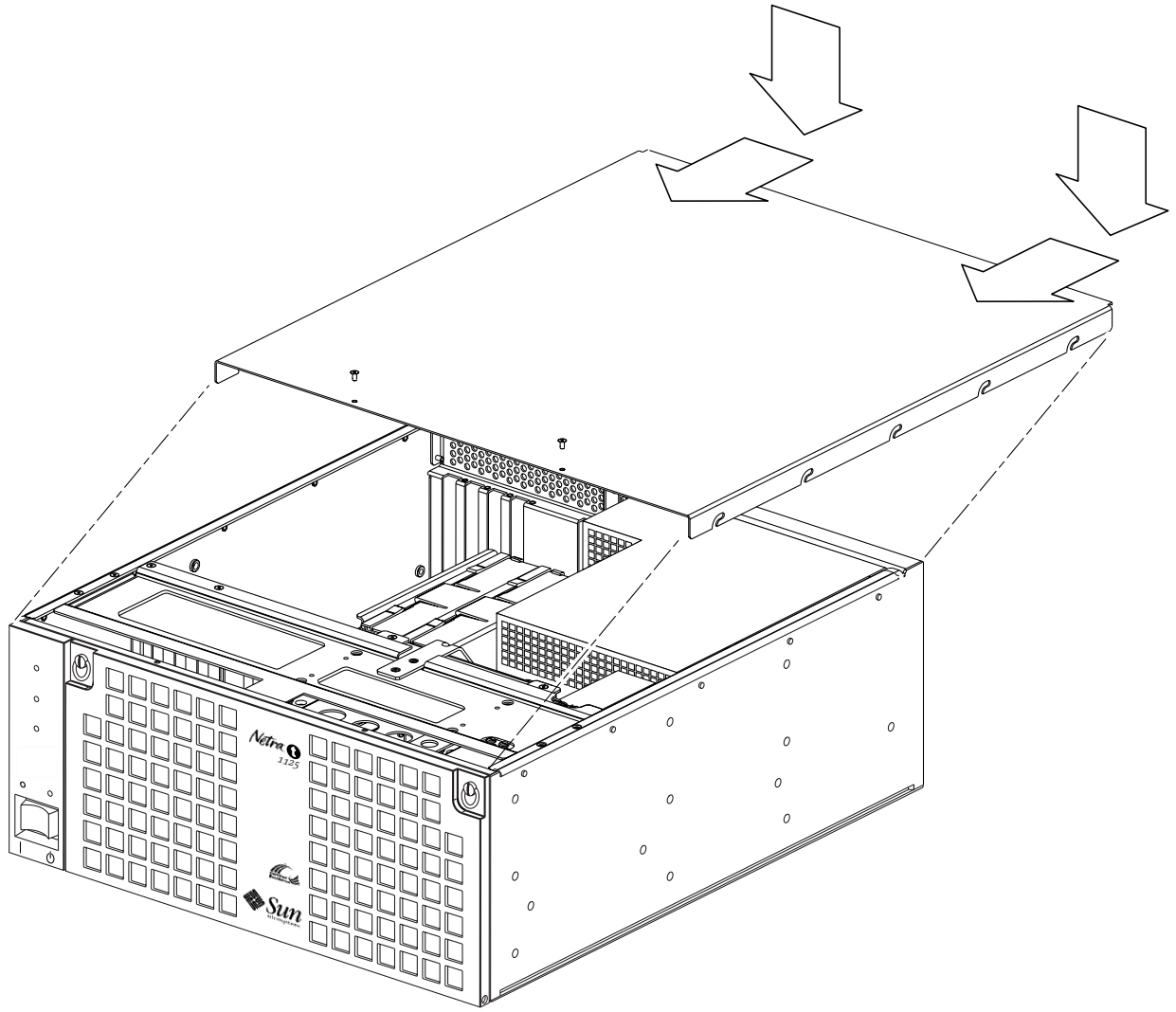
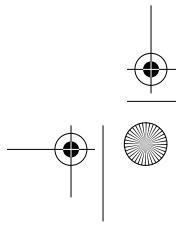
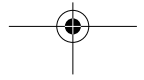
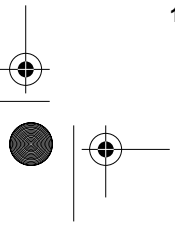
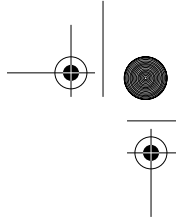

FIGURE 1-10 Replacing the Top Access Cover



CHAPTER 2

Back Panel Connectors

2.1 Connector Layout

FIGURE 2-1 shows the locations of the Netra t 1120/1125 system back panel connectors.

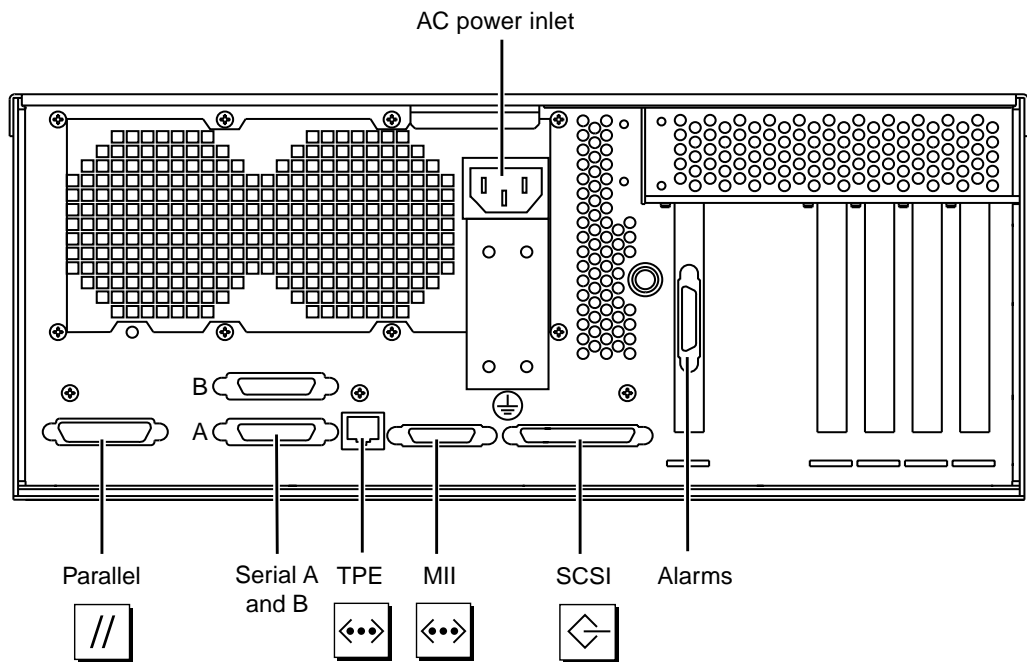

FIGURE 2-1 Back Panel Connectors

2.2 Serial Connectors

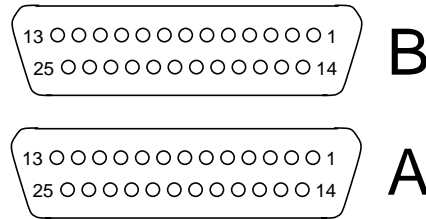

FIGURE 2-2 DB-25 Serial Connectors

TABLE 2-1 Serial Connector Pinouts, RS423/RS232

Pin	Function	I/O	Signal Description
1	none	none	Not connected
2	TxD	O	Transmit Data
3	RxD	I	Receive Data
4	RTS	O	Ready To Send
5	CTS	I	Clear To Send
6	DSR	I	Data Set Ready
7	Gnd		Signal Ground
8	DCD	I	Data Carrier Detect
9-14	none	none	Not connected
15	TRxC	I	Transmit Clock
16	none	none	Not connected
17	RTxC	I	Receive Clock
18-19	none	none	Not connected
20	DTR	O	Data Terminal Ready
21-23	none	none	Not connected
24	TxC	O	Transmit Clock
25	none	none	Not connected

Note: For information about serial port jumpers on the Netra t 1120/1125 system main logic board, see Chapter 5 "Main Logic Board Jumpers".

2.3 Media Independent Interface (MII) Connector

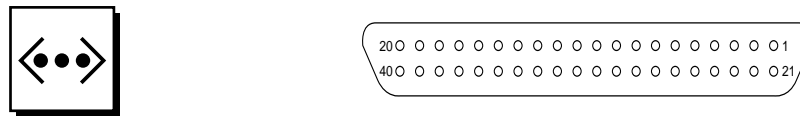

FIGURE 2-3 40-Pin Miniature-D MII Connector

TABLE 2-2 Connector Pinouts

Pin	Function	Pin	Function
1	+5V	18	COL
2	MDIO	19	CRS
3	MDC	20	+5V
4	RXD<3>	21	+5V
5	RXD<2>	22	Signal Ground
6	RXD<1>	23	Signal Ground
7	RXD<0>	24	Signal Ground
8	RX_DV	25	Signal Ground
9	RX_CLK	26	Signal Ground
10	RX_ER	27	Signal Ground
11	TX_ER	28	Signal Ground
12	TX_CLK	29	Signal Ground
13	TX_EN	30	Signal Ground
14	TXD<0>	31	Signal Ground
15	TXD<1>	32	Signal Ground
16	TXD<2>	33	Signal Ground
17	TXD<3>	34	Signal Ground

TABLE 2-2 Connector Pinouts (*Continued*)

Pin	Function	Pin	Function
35	Ground	38	Signal Ground
36	Ground	39	Signal Ground
37	Ground	40	+5V

2.3.1 Cable-Type Connectivity

The following types of Ethernet cable can be connected to the 40-pin MII connector:

- Fiber (connected to an external transceiver)
- Shielded twisted-pair (STP).

2.3.2 External Cable Length

TABLE 2-3 MII External Cable Lengths

Cable Type	Application(s)	Max Length (Metric)	Max Length (Imperial)
40-conductor (20 signal-ground twisted-pair) shielded (STP)	All external MII	0.5m	20in
Shielded twisted-pair category 5 (STP-5, "data grade")	10BASE-T	1000m	3282ft
Shielded twisted-pair category 5 (STP-5, "data grade")	100BASE-T	100m	327ft

2.4 Twisted-Pair Ethernet (TPE) Connector

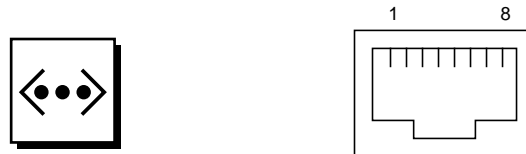

FIGURE 2-4 RJ45 TPE Socket

TABLE 2-4 TPE Connector Pinouts

Pin	Description	Pin	Description
1	Transmit Data +	5	Common Mode Termination
2	Transmit Data -	6	Receive Data -
3	Receive Data +	7	Common Mode Termination
4	Common Mode Termination	8	Common Mode Termination

2.4.1 TPE Cable-Type Connectivity

The following types of twisted-pair Ethernet cable can be connected to the 8-pin TPE connector:

- For 10BASE-T applications, shielded twisted-pair (STP) cable:
 - Category 3 (STP-3, “voice grade”)
 - Category 4 (STP-4)
 - Category 5 (STP-5, “data grade”)
- For 100BASE-T applications, shielded twisted-pair category 5 (STP-5, “data grade”) cable.

TABLE 2-5 TPE STP-5 Cable Lengths

Cable Type	Application(s)	Max Length (Metric)	Max Length (Imperial)
Shielded twisted pair category 5 (STP-5, “data grade”)	10BASE-T	1000m	3282ft
Shielded twisted pair category 5 (STP-5, “data grade”)	100BASE-T	100m	327ft

2.5 SCSI Connector

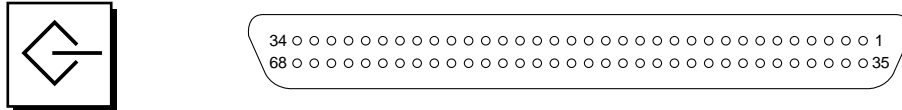

FIGURE 2-5 68-Pin SCSI Connector

TABLE 2-6 68-Pin SCSI Connector Pinouts

Pin	Signal Name	Pin	Signal Name
1	Ground	21	Ground
2	Ground	22	Ground
3	Ground	23	Ground
4	Ground	24	Ground
5	Ground	25	Ground
6	Ground	26	Ground
7	Ground	27	Ground
8	Ground	28	Ground
9	Ground	29	Ground
10	Ground	30	Ground
11	Ground	31	Ground
12	Ground	32	Ground
13	Ground	33	Ground
14	Ground	34	Ground
15	Ground	35	-DB<12>
16	Ground	36	-DB<13>
17	TERMPWR	37	-DB<14>
18	TERMPWR	38	-DB<15>
19	Not connected	39	-PAR<1>
20	Ground	40	-DB<0>
41	-DB<1>	55	-ATN

TABLE 2-6 68-Pin SCSI Connector Pinouts (*Continued*)

Pin	Signal Name	Pin	Signal Name
42	-DB<2>	56	Ground
43	-DB<3>	57	-BSY
44	-DB<4>	58	-ACK
45	-DB<5>	59	-RST
46	-DB<6>	60	-MSG
47	-DB<7>	61	-SEL
48	-PAR<0>	62	-CD
49	Ground	63	-REQ
50	TERM.DIS	64	-IO
51	TERMPWR	65	-DB<8>
52	TERMPWR	66	-DB<9>
53	Reserved	67	-DB<10>
54	Ground	68	-DB<11>

Note – All signals shown in TABLE 2-6 on page 2-6 are active low.

2.5.1 SCSI Implementation

- SCSI-3 Fast-20 (UltraSCSI) parallel interface
- 16-bit SCSI bus
- 40Mbps data transfer rate
- Support for 16 SCSI addresses:
 - Target 0 to 6 and 8 to F for devices
 - Target 7 reserved for SCSI host adapter on main logic board
- Support for up to four internal SCSI devices (including the host adapter):
 - SCSI disk drive target 0 (lower drive slot)
 - SCSI disk drive target 1 (upper drive slot)
 - SCSI CD-ROM drive target 6 or SCSI tape drive target 5
- Support for external 8-bit and 16-bit SCSI devices via 68-pin SCSI connector.

2.5.2 SCSI Cabling and Configuration

The SCSI-3 Fast-20 (UltraSCSI) specification requires that the external SCSI bus length be limited to 3m (10ft) for less than five devices (internal and external), and 1.5m (5ft) for five to eight devices. When SCSI-3 and SCSI-2 devices are connected to the Netra t 1120/1125 system SCSI bus, the system enables each device to operate at its respective data transfer rate. The last external SCSI device in a daisy-chain must be terminated internally (active termination) or with an external terminator according to Forced-Perfect Termination (FPT) technology.

2.5.2.1 SCSI Cabling Procedure

1. **Count the number of SCSI devices on the system SCSI bus. Be sure to count the host adapter as a SCSI device.**
2. **Determine the total SCSI bus length.**

TABLE 2-7 Determining SCSI Bus Length

SCSI Implementation	Bus Width	Data Transfer Rate, Mb/s	Number of Devices	SCSI Bus Length
SCSI-2, Fast	8 bits	10	1-8	6.0m
SCSI-2, Fast/Wide	16 bits	20	1-8	6.0m
SCSI-3 Parallel Interface, Fast-20 Wide (UltraSCSI) (WideUltra)	16 bits	40	1-4	3.0m
SCSI-3 Parallel Interface, Fast-20 Wide (UltraSCSI) (WideUltra)	16 bits	40	5-8*	1.5m

* The maximum number of single-ended/differential SCSI devices is 16.

3. **Verify the cable type used to connect external SCSI devices. You must use Fast-20 SCSI cable(s).**

Ensure that the total SCSI cable length does not exceed the permissible total SCSI bus length.

2.5.2.2 SCSI-2 (Fast Wide SCSI) External Devices

If you connect SCSI-2 (Fast Wide SCSI, 20Mb data transfer rate) external devices to a Netra t 1120/1125 system, follow these cabling and configuration guidelines (as shown in FIGURE 2-6) to ensure proper device addressing and operation:

- If all external mass storage devices use 68-pin connectors, connect all non-Sun devices to the Netra t 1120/1125 system first and follow them with Sun devices. Sun devices use auto-termination.
- If external mass storage devices consist of 68-pin Sun devices and 50-pin devices, connect the Sun 68-pin devices to the Netra t 1120/1125 system first and terminate the daisy chain with the 50-pin device and its terminator.
- The total SCSI bus length for all external SCSI devices is 6.0m (19.7ft).

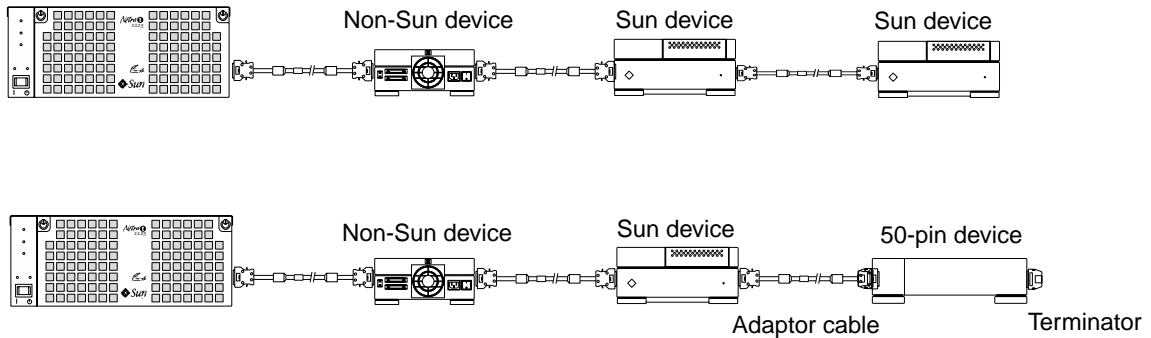

FIGURE 2-6 Connecting External Mass Storage Devices

2.6 Alarms Port

The alarms connector is located on the alarms card. This connector is a male DB-15 and TABLE 2-8 lists each connector line assignment.

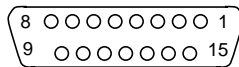

FIGURE 2-7 Alarms Connector Configuration

TABLE 2-8 Alarms Connector Line Assignments

Pin	Signal Name	Pin	Signal Name
1	RESET+	9	ALARM1 COM
2	RESET-	10	ALARM1 NC
3	Not connected	11	ALARM2 NO
4	Not connected	12	ALARM2 COM
5	ALARM3 COM	13	ALARM2 NC
6	ALARM3 NO	14	Not connected
7	ALARM3 NC	15	Not connected
8	ALARM1 NO		

2.6.1 Alarm Output Description

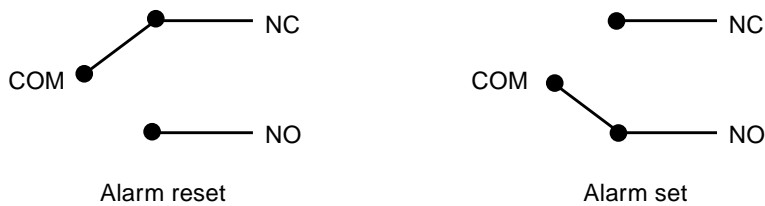

FIGURE 2-8 Dry Contact Outputs

The reset signal requirement is a pulse of 250 ± 50 ms duration applied to pin 1. The pulse should be between +4Vdc and +12Vdc with respect to pin 2.

2.7 Parallel Interface

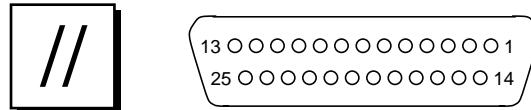
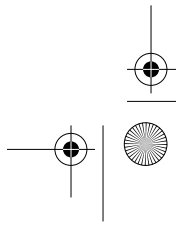
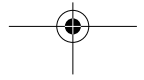
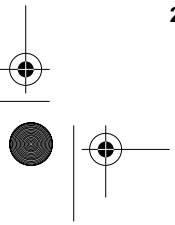
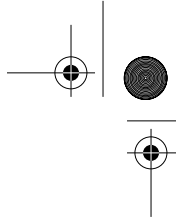

FIGURE 2-9 DB-25 Parallel Connector

TABLE 2-9 Parallel Connector Pinouts

Pin	Description	Pin	Description
1	Data_Strobe_L	14	AFXN_L
2	Data0	15	ERROR_L
3	Data1	16	RESET_L
4	Data2	17	IN_L
5	Data3	18	Ground
6	Data4	19	Ground
7	Data5	20	Ground
8	Data6	21	Ground
9	Data7	22	Ground
10	ACK_L	23	Ground
11	BUSY	24	Ground
12	PERROR	25	Ground
13	SELECT_L		



CHAPTER 3

Twisted-Pair Ethernet Link Test

Read this chapter if you are connecting your Netra t 1120/1125 system to a twisted-pair Ethernet (TPE) network. This chapter contains important information for configuring your system to communicate correctly over a TPE network. If you have no experience with TPE networks, ask your system or network administrator to perform the procedures in this chapter.

Note – In 100BASE-T networks, the link test function must be enabled at both the host and the hub. If your host is connected to a 100BASE-T network, you must not disable the host link test function.

3.1 Overview

- The twisted-pair Ethernet link integrity test is a function defined by the IEEE 802.3 10BASE-T specification.
- For a networked workstation (host) to communicate with a network hub, the link test state (enabled or disabled) must be the same on the host and hub. The link test *must* be enabled for 100BASE-T.
- If either the host or hub does not share the link test enabled/disabled state of the other, they cannot communicate effectively with each other.

FIGURE 3-1 on page 3-2 gives an example of a star configuration Local Area Network (LAN), showing the relationship of hosts to a hub.

FIGURE 3-2 on page 3-3 shows the importance of ensuring that the host and hub link test settings match in a 10BASE-T network.

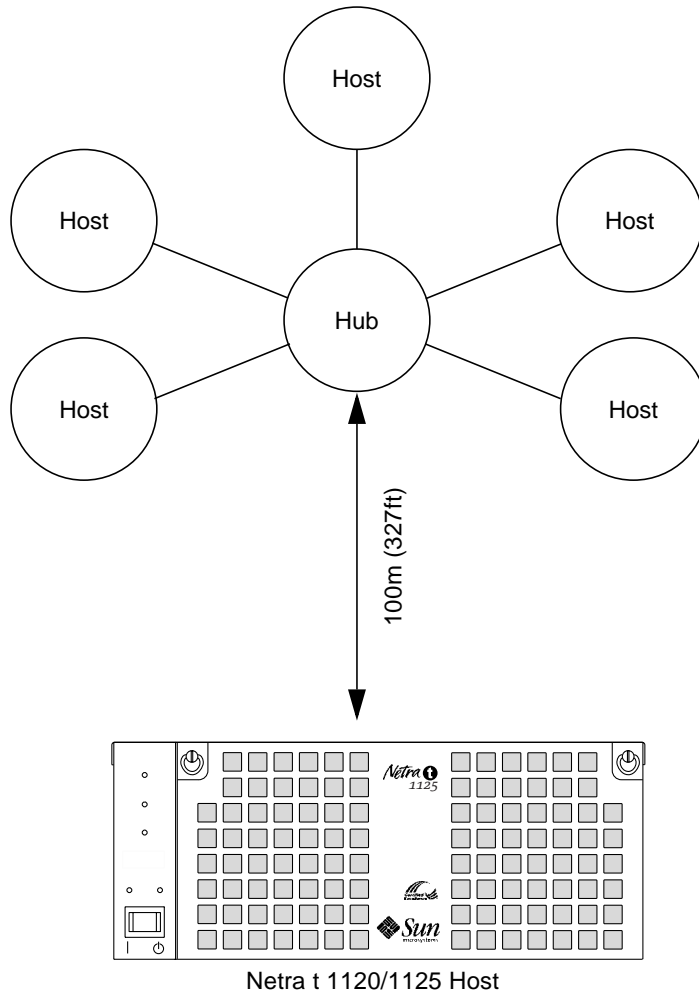

FIGURE 3-1 Hosts and Hub in a Local Area Network

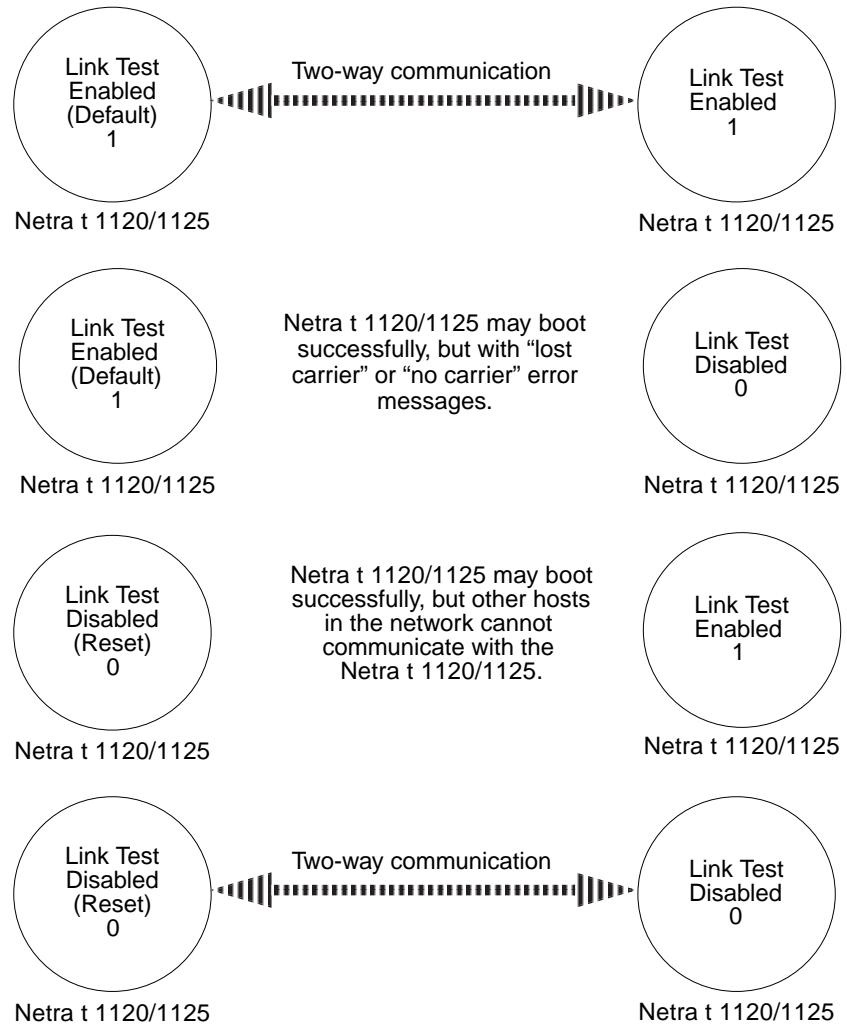

FIGURE 3-2 Ensuring Host Hub Communication in a 10BASE-T Network

3.2 Technical Discussion

The twisted-pair Ethernet link integrity test determines the state of the twisted-pair cable link between the host and the hub in a network. Both the host and hub regularly transmit a link test pulse. When either the host or hub has not received a link test pulse within a certain amount of time (50 to 150ms), it makes the transition from the link-pass state to the link-fail state and remains in the link-fail state until it once again receives regular link test pulses.

The link integrity test is specific to twisted-pair Ethernet and is not applicable to the other physical layer implementations of IEEE 802.3 such as 10BASE5 ("thicknet") or 10BASE2 ("thinnet").

The link test function at the host or hub is either enabled (link test enabled or 1) or disabled (link test disabled or 0). The IEEE 802.3 10BASE-T specification requires that the link test be enabled at both the host and the hub.

Although link test disabled does not conform to the specification, it is often encountered in real-world 10BASE-T network installations. Some hubs from various vendors can exhibit any of the following:

- Link test is "hardwired" enabled—link test is always enabled.
- Link test is "hardwired" disabled—link test is always disabled.
- Link test is configurable—the network administrator may enable or disable link test.

3.3 Troubleshooting

If you have connected a Netra t 1120/1125 host to a hub using twisted-pair Ethernet cable and observe either "no carrier" messages or failure to communicate effectively with another host in the same network, look first at the hub. If it supports configurable link test, make sure "link test enabled" is configured. This is usually done by setting a hardware switch.

If the hub does not support configurable link test, refer to the hub manufacturer's documentation. Check to see if your hub is hardwired for link test disabled. If it is, you must follow the procedure in Section 3.5 "To Check or Disable the Link Test" on page 3-5 to disable the link test at your Netra t 1120/1125 host.

3.4 Moves and Changes

If the Netra t 1120/1125 host is physically moved to another network location or if the hub is reconfigured, remember to refer back to FIGURE 3-2 on page 3-3. Unless the new network relationship between the host and the hub is functional (that is, 1-1 link test enabled-link test enabled or 0-0 link test disabled-link test disabled), there will be no full, regular two-way communication between the host and the hub.

3.5 To Check or Disable the Link Test

To check the link test state of a Netra t 1120/1125 host:

1. If you do not see the `ok` prompt, send a **Break** command.
2. At the `ok` prompt, type:

```
ok printenv tpe-link-test?
tpe-link-test?          true          true
ok
```

The output shows the current link test state (true, or enabled), followed by the default state (true, or enabled).

To disable the host's link test function:

3. Type the following commands:

```
ok setenv tpe-link-test? false
tpe-link-test? =      false
ok reset-all
```

4. Boot the host and verify that the transceiver cable problem messages do not appear by typing either `boot net` or `boot disk` and pressing **Return**.

3.6 To Enable the Link Test

1. If you do not see the `ok` prompt, send a Break command.
2. At the `ok` prompt, type:

```
ok printenv tpe-link-test?  
tpe-link-test?      false           true  
ok
```

The above screen shows the current link test state (false, or disabled), followed by the default state (true, or enabled).

3. To enable the host's link test function, type the following commands:

```
ok setenv tpe-link-test? true  
tpe-link-test? =   true  
ok reset-all
```

4. Boot the host and verify that the transceiver cable problem messages do not appear by typing either `boot net` or `boot disk` and pressing Return.

CHAPTER 4

Modem Setup

Any modem compatible with CCITT V.24 can be connected to the Netra t 1120/1125 serial ports. Modems can be set up to function in one of three ways:

- Dial out only
- Dial in only
- Bidirectional calls.

4.1 To Set Up the Modem

To set up your modem:

1. **Become root and type `admintool`.**

```
% su
Password:
# admintool
```

2. **Click on Serial Port Manager.**
3. **Select Port a or Port b for your modem connection.**
4. **Click on Edit.**
The Serial Port Manager: Modify Service window is displayed.
5. **Choose the Expert level of detail.**
6. **From the Use Template menu, choose one of the following:**
 - a. **Modem - Dial-Out only**
 - b. **Modem - Dial-In only**

c. Modem – Bidirectional

7. Click on Apply.
8. Set your modem auto-answer switch to one of the following:
 - Off – Dial-Out Only
 - On – Dial-In Only
 - On – Bidirectional

4.2 Serial Port Speed Change

To change the speed of a serial port, you must edit the `/etc/remote` file as follows:

1. Become super user, and type `cd /etc`.

```
% su
Password:
# cd /etc
```

2. Type `vi remote`.
3. Type `tip speed device-name`.
Typical speeds are 9600, 19200 to 38400 bps.
The device name is the serial port name, for example,
`/dev/tty[a,b]` or `/dev/term/[a,b]`.
4. Press `<Esc>` and type `:wq` to save your file change(s) and to exit from the `vi` text editor.

4.3 Recommendations

For a modem-to-host (system) connection, use an RS423/RS232 straight-through cable with DB-25 male connectors at both ends.

CHAPTER 5

Main Logic Board Jumpers

The jumper settings given in this chapter refer to the etchings on the main logic board. The jumpers are labeled with the letter “J” followed by a four-digit number (see FIGURE 5-1).

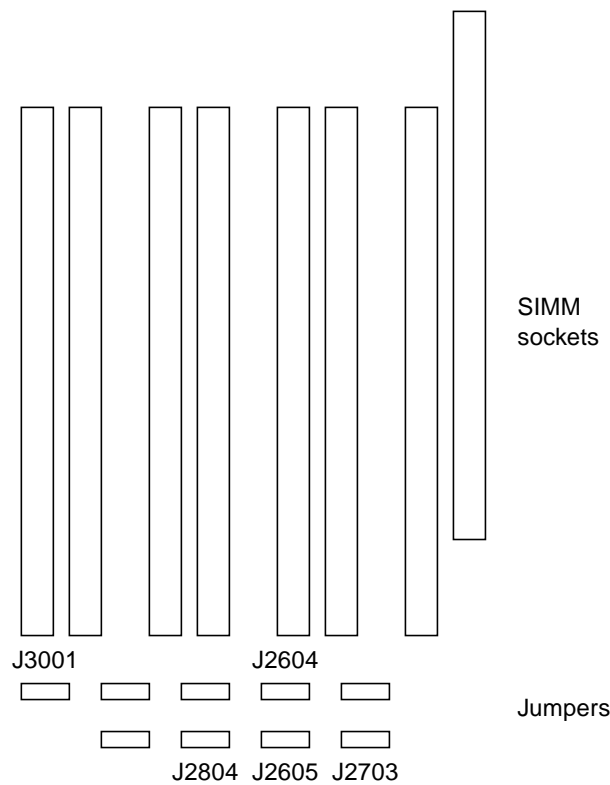

FIGURE 5-1 Jumper Locations on the Main Logic Board

5.1 To Identify Jumpers

Jumpers are marked on the main logic board with part numbers. For example, the serial port jumpers are marked J2604 and J2605. Jumper pins are located immediately adjacent to the part number. Pin 1 is marked with an asterisk in the position shown in FIGURE 5-2.

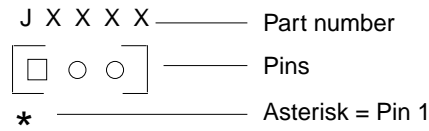

FIGURE 5-2 To Identify Jumper Pins

TABLE 5-1 User-Configurable Jumpers

Jumper	Functionality
J2703	Flash PROM Write Protect/Write Enable
J2605 J2604	Serial Ports B and A RS423 and RS232
J2804	Flash PROM Hi-Lo Booting

5.2 Flash PROM Jumpers

The Netra t 1120/1125 system uses flash PROMs. Flash PROMs enable:

- Reprogramming of specific code blocks.
- Remote reprogramming of the PROM chip by a system administrator over a local area network.

The default shunt setting of J2703 is on pins 1 and 2. This prevents the flash PROM chip from being reprogrammed. Placing the shunt on pins 2 and 3 enables reprogramming of the flash PROM chip (see TABLE 5-2).

Note – After reprogramming your system flash PROM, make sure you return the flash PROM Write Protect/Enable jumper (J2703) to the Write Protect position to increase system security.

TABLE 5-2 Flash PROM Jumper Settings

Jumper	Pins 1 + 2 Select	Pins 2 + 3 Select	Default Jumper on Pins	Signal Controlled
J2703	Write Protect	Write Enable	1 + 2	FLASH PROM PROG ENABLE
J2804	High Half Booting	Normal Booting	2 + 3	XOR LOGIC SET

5.3 Serial Port Jumpers

The serial port jumpers on the main logic board enable you to configure the two DB-25 serial ports on the system unit back panel for either RS423 or RS232 signal levels. RS423 levels are the default standard for North American users. RS232 levels are required for telecommunication in nations of the European Community (see TABLE 5-3).

TABLE 5-3 Serial Port Jumper Settings

Jumper	Pins 1 + 2 Select	Pins 2 + 3 Select	Default Jumper on Pins	Signal Controlled
J2604	RS232	RS423	2 + 3	RS232/RS423 SEL
J2605	RS232	RS423	2 + 3	RS232/RS423 SEL

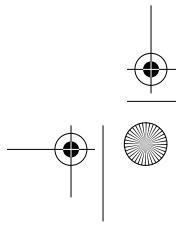
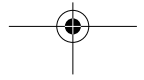
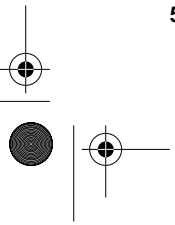
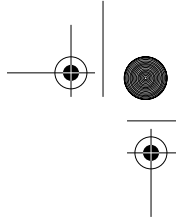
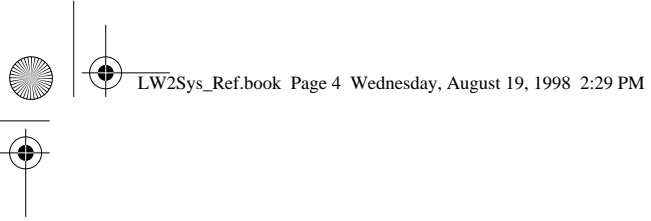

APPENDIX **A**

Functional Description

This Appendix contains a functional description for the Netra t 1120/1125 system.

A.1 System

See FIGURE A-1. The system is an UltraSPARC port architecture (UPA) based machine that uses peripheral component interconnect (PCI) as the I/O expansion bus. The CPU modules and U2P ASIC (UPA-to-PCI bridge) communicate with each other using the UPA protocol. The CPU modules and the U2P ASIC are UPA master-slave devices. The QSC ASIC routes UPA requests packets through the UPA address bus and controls the flow of data using the XB9+ ASIC.

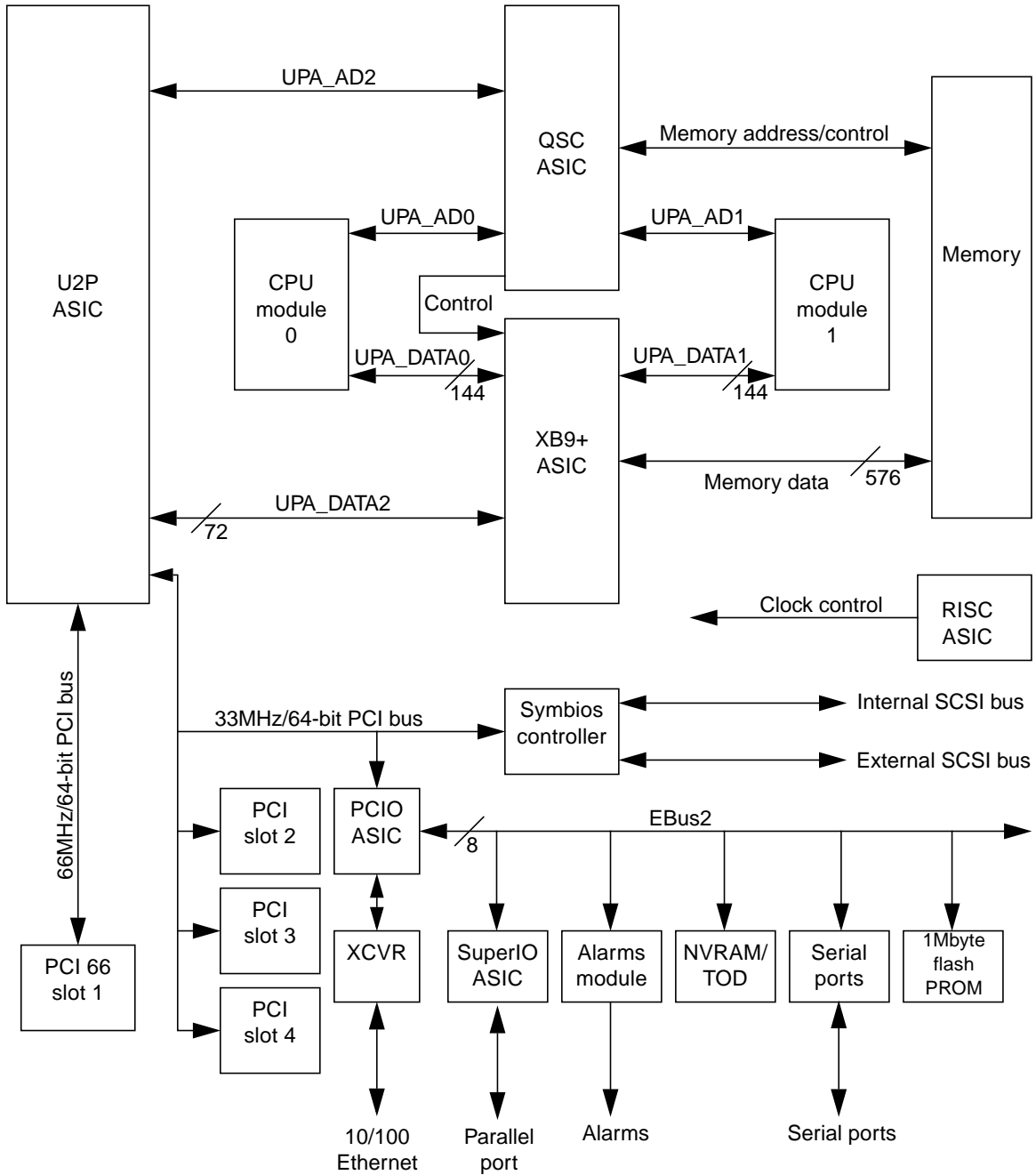

FIGURE A-1 System Unit Functional Block Diagram

A.2 UPA

The UltraSPARC port architecture (UPA) provides a packet-based interconnection between the UPA clients: CPU modules and U2P ASIC. Electrical interconnection is provided through three address buses and three data buses.

The three address buses are:

- UPA address bus 0 (UPA_AD0)
- UPA address bus 1 (UPA_AD1)
- UPA address bus 2 (UPA_AD2)

The three data buses are:

- UPA data bus 0 (UPA_DATA0)
- UPA data bus 1 (UPA_DATA1)
- UPA data bus 2 (UPA_DATA2)

Refer to FIGURE A-1.

UPA_AD0, UPA_AD1 and UPA_AD2 are full 36-bit bidirectional buses that connect the QSC ASIC to the CPU modules and the U2P ASIC. UPA_DATA0 and UPA_DATA1 are bidirectional 144-bit data buses (128 bits of data and 16 bits of ECC) that connect the CPU modules to the XB9+ ASIC. UPA_DATA2 is a bidirectional 72-bit data bus (64 bits of data and eight bits of ECC) that connects the U2P ASIC to the XB9+ ASIC.

TABLE A-1 lists UPA port identification assignments. FIGURE A-2 illustrates how the UPA address and data buses are connected between the UPA and the UPA clients.

TABLE A-1 UPA Port Identification Assignments

UPA Slot Number	UPA Port ID <4:0>
CPU module slot 0	0x0
CPU module slot 1	01
U2P ASIC	0x1f

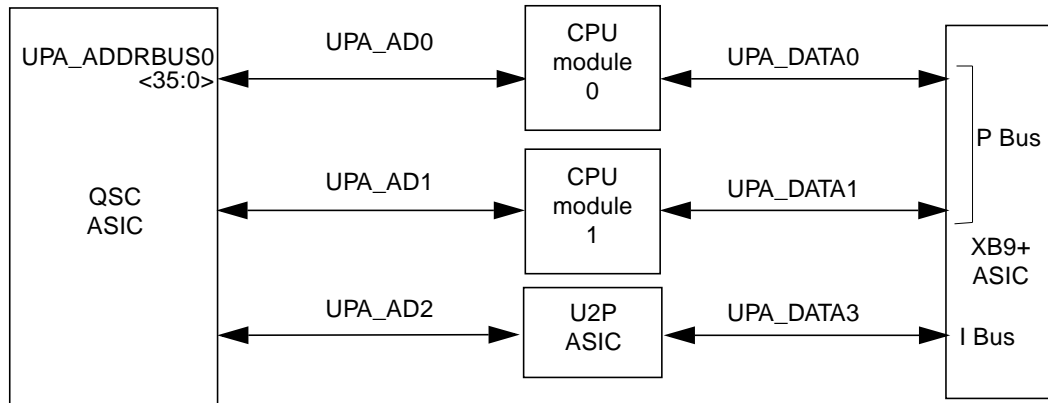

FIGURE A-2 UPA Address and Data Buses Functional Block Diagram

A.3 PCI Bus

The peripheral component interconnect (PCI) bus is a high-performance 32- or 64-bit bus with multiplexed address and data lines. The PCI bus provides electrical interconnect between highly integrated peripheral controller components, peripheral add-on devices, and the processor/memory system.

There are two PCI buses (FIGURE A-1). The first bus is a one-slot, 3.3Vdc, 64-bit or 32-bit, 66MHz or 33MHz bus. The second bus is a three-slot, 5.0Vdc, 64-bit or 32-bit, 33MHz bus. Both buses are controlled by the UPA-to-PCI bridge (U2P) ASIC. There are also two on-board controllers, the Symbios 53C876 SCSI controller and the PCI to Ebus/Ethernet controller (PCIO) ASIC, on the 33MHz PCI bus.

A.3.1 U2P ASIC

The UPA-to-PCI bridge (U2P) ASIC controls the PCI buses. It forms the bridge from the UPA bus to the PCI buses. For a brief description of the U2P ASIC, see Section A.13.4 "U2P" on page A-28.

A.3.2 Symbios 53C876 SCSI Controller

The Symbios 53C876 dual channel SCSI controller provides electrical connection between the system board and separate internal and external SCSI buses. The controller also provides the SCSI bus control.

A.3.3 PCIO ASIC

The PCI-to-Ebus/Ethernet controller (PCIO) ASIC bridges the PCI bus to the Ebus, enabling communication between the PCI bus and all miscellaneous I/O functions as well as the connection to slower on-board functions. The PCIO ASIC also embeds the Ethernet controller. For a brief description of the PCIO ASIC, see Section A.13.3 "PCIO" on page A-28.

A.4 UltraSPARC II Processor

The UltraSPARC II processor is a high-performance, highly-integrated super-scalar processor implementing the SPARC-V9 64-bit RISC architecture. The UltraSPARC II processor is capable of sustaining the execution of up to four instructions per cycle even in the presence of conditional branches and cache misses. This sustained performance is supported by a decoupled prefetch and dispatch unit with instruction buffer. The UltraSPARC II processor module provides 1, 2 or 4Mbyte Ecache, with system operating frequencies from 300MHz.

UltraSPARC II processor characteristics and associated features include:

- SPARC-V9 architecture compliance
- Binary compatibility with all SPARC application code:
- Multi-processing support
- Snooping or directory-based protocol support
- Four-way superscalar design with nine execution units
- Four integer execution units
- Three floating-point execution units
- 64-bit address pointers
- 16Kb non-blocking data cache
- 16Kb instruction cache
- Single cycle branch following
- Power management
- Software prefetch instruction support
- Multiple outstanding requests.

A.5 Memory System

The memory system (FIGURE A-3) consists of three components: the QSC ASIC, the XB9+ ASIC and the DRAM SIMMs. The QSC ASIC generates memory addresses and control signals to the SIMMs. The QSC ASIC also coordinates the data transfers among the SIMMs through the 144-bit-wide processor data bus and the 72-bit-wide I/O data bus (see FIGURE A-1 on page A-2). 16, 32, 64 and 128Mbyte SIMMs are supported by the memory module. When all SIMM slots are populated with 128Mbyte SIMMs, maximum memory capacity is 2Gbytes.

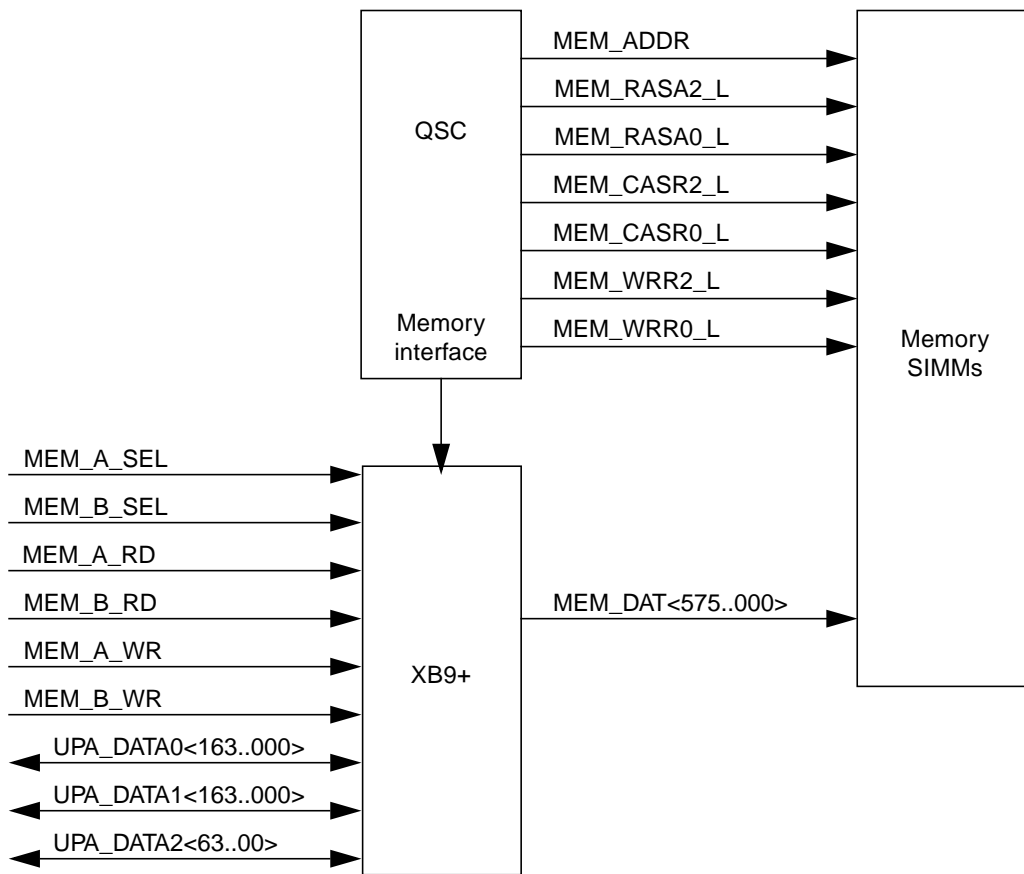

FIGURE A-3 Memory System Functional Block Diagram

As shown in FIGURE A-5, the memory module is arranged in four banks. SIMMs are always accessed four at a time. Consequently, the memory system must be populated in groups of four (quad) and individual SIMMs within a quad should be of equal capacity. FIGURE A-3 illustrates SIMM row mapping.



Caution – Failure to populate a SIMM quad with SIMMs of equal capacity will result in inefficient use of memory resource or system failure.

The memory system normally operates in a non-interleave mode. To operate in the interleave mode, three conditions must exist:

- The interleave bit in the QSC ASIC is set.
- Any bank containing SIMMs is fully populated.
- All SIMMs in the same bank have identical capacity.

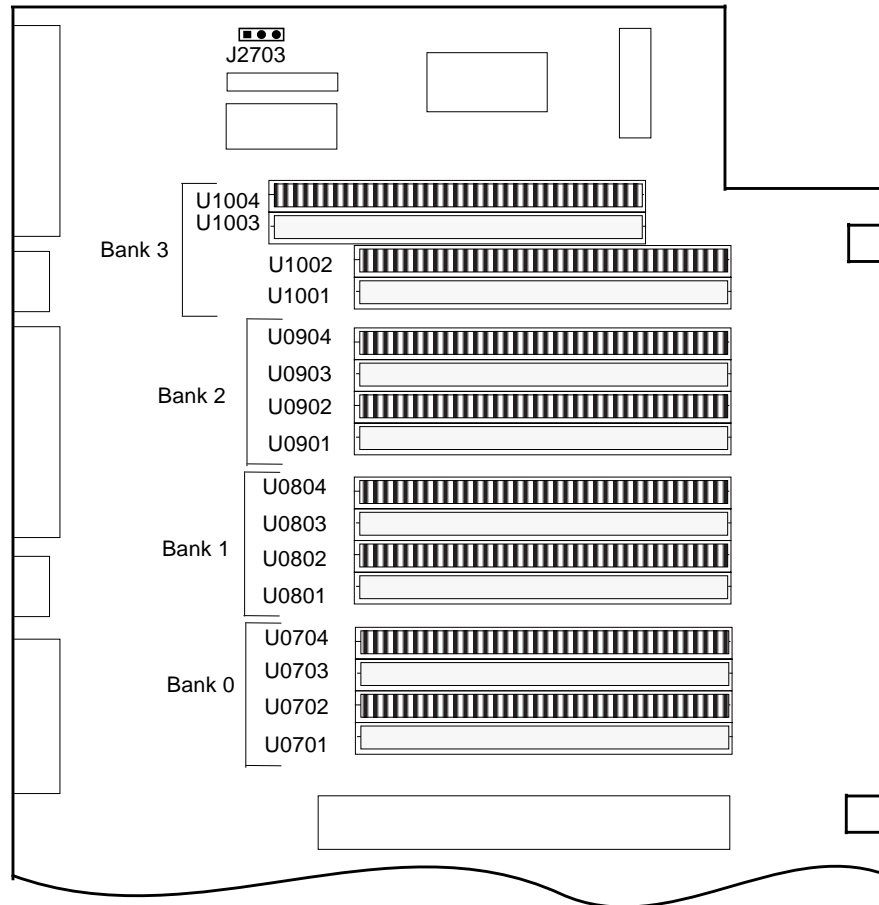

FIGURE A-4 SIMM Mapping

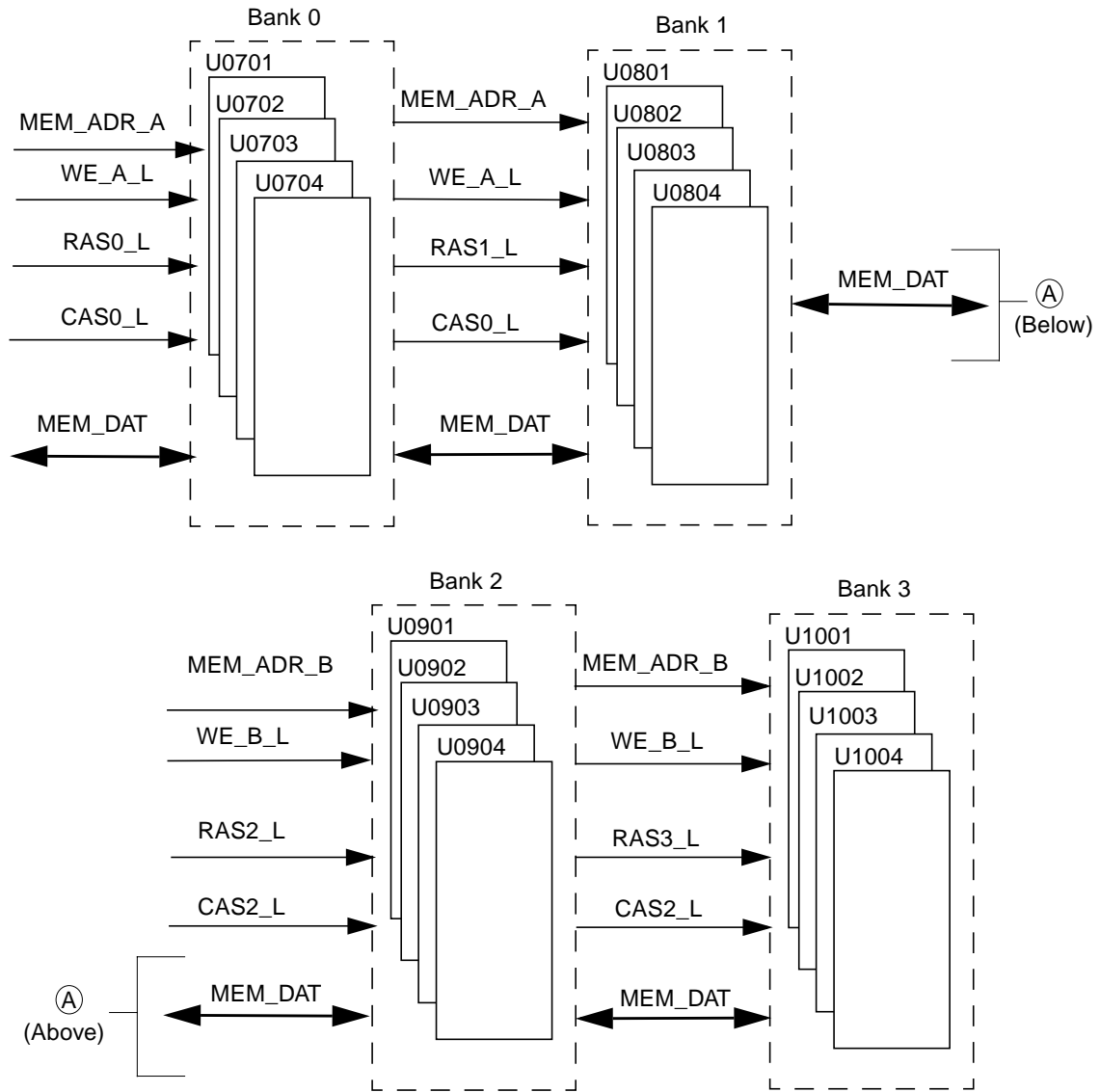

FIGURE A-5 Memory Module Functional Block Diagram

A.5.1 SIMM

The SIMM is a 60ns, fast-page-mode-style SIMM. Three SIMM densities are supported in the system unit: 32Mbyte, 64Mbyte and 128Mbyte. The minimum memory capacity is 128Mbyte (four 32Mbyte SIMMs). The maximum memory capacity is 2Gb (16 128Mbyte SIMMs).

A block of data (64 bytes) always comes from one quad of SIMMs. An error code, containing the address of where a failure occurred as well as the associated syndrome, is logged when an ECC error occurs.

There are a total of four SIMM quads in the system. TABLE A-2 matches SIMM quads to U numbers. TABLE A-3 lists physical address maps to SIMM quads.

TABLE A-2 DIMM Bank-to-U-Number Mapping

DIMM Bank	U Number
0	U0701 thru U0704
1	U0801 thru U0804
2	U0901 thru U0904
3	U1001 thru U1004

TABLE A-3 IL = 0, DIMM Bank-to-Physical Address Mapping

DIMM Bank	PA[30:28]
0	0000
	0001
1	0010
	0011
2	1000
	1001
3	1010
	1011

A.5.1.1 Memory System Timing

The QSC ASIC generates the memory addresses and control signals to the memory system. The UPA clock is the clock source for the QSC ASIC and operates at a 120MHz frequency. FIGURE A-6 through to FIGURE A-10 show the memory timing at the 120MHz UPA frequency.

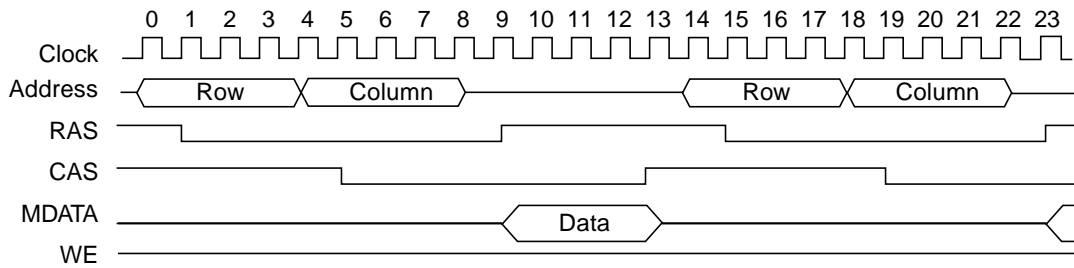

FIGURE A-6 120MHz (8.33ns) Timing - Two Reads to the Same Bank

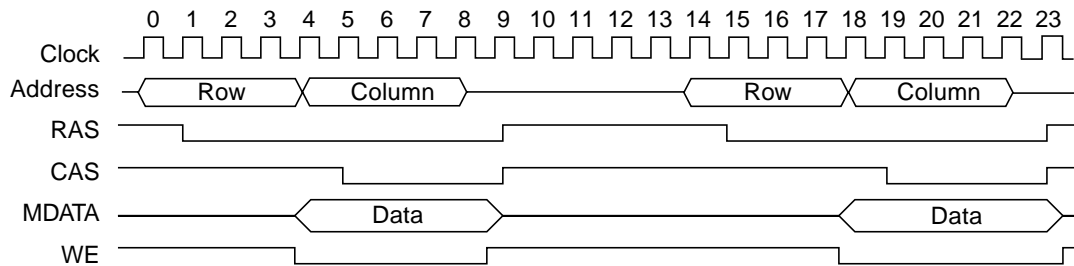

FIGURE A-7 120MHz (8.33ns) Timing - Two Writes to the Same Bank

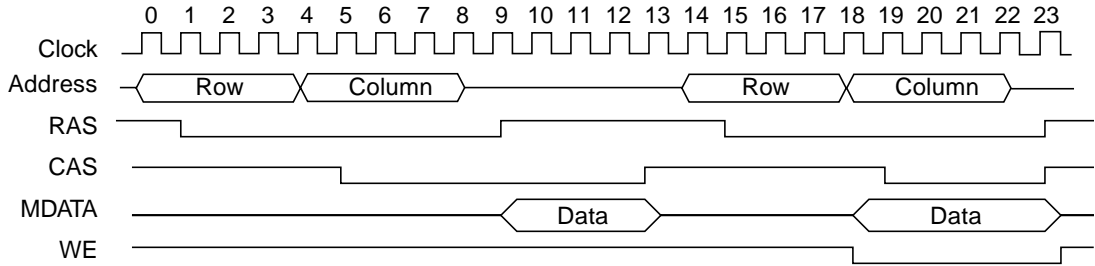

FIGURE A-8 120MHz (8.33ns) Timing - Read/Write to Same Bank

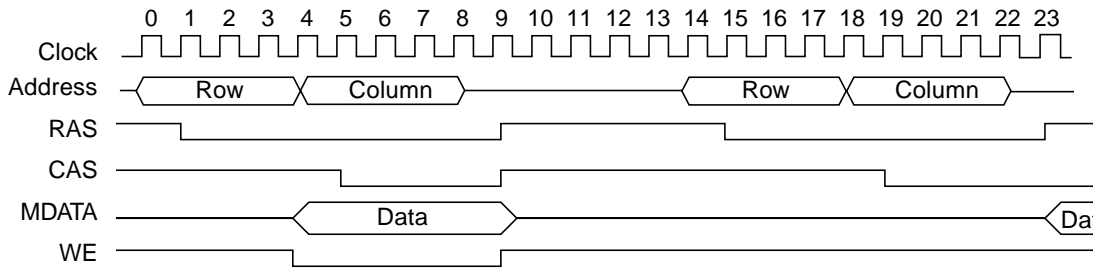

FIGURE A-9 120 MHz (8.33ns) Timing - Write/Read to Same Bank

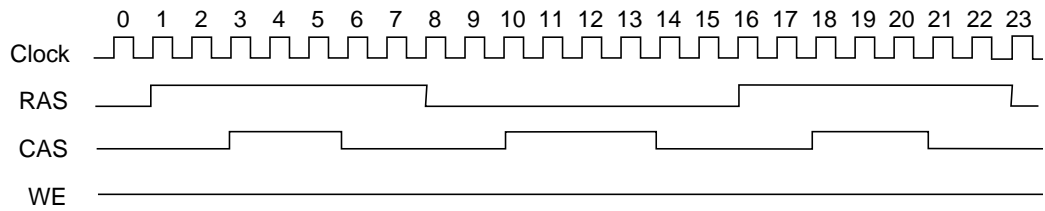

FIGURE A-10 120 MHz (8.33ns) Timing - Refresh Cycle

A.6 Peripherals

The system unit supports up to two fixed disk drives. An optional CD-ROM drive, 2.5Gbyte, 4mm or 8mm tape drive are also supported.

A.6.1 Disk Drives

The system unit supports three SCSI disk drive capacities: 4.2, 9 and 18Gbyte.

The 4.2Gbyte disk drive is of 1in form factor; the 9Gbyte disk is of 1in or 1.6in form factor, and the 18Gbyte disk drive is of 1.6in form factor. All disk drives have a single connector configuration.

A drive bracket is used to mount the drive. TABLE A-4 lists the supported disk drives.

- The *4.2Gb Disk Drive Specifications*, part number 802-7744, provides installation instructions, power requirements and performance data for the 4.2Gbyte disk drive.
- The *9Gb Disk Drive Specifications*, part number 802-7745, provides installation instructions, power requirements and performance data for the 9Gbyte disk drive.
- The *18Gb Disk Drive Specifications*, part number 805-3936, provides installation instructions, power requirements and performance data for the 18Gbyte disk drive.

TABLE A-4 Supported Disk Drives

Form Factor Dimension	Disk Drive Capacity	Wide	RPM	Seek Time
1.00in (25.4mm)	4.2Gbyte	Yes	7200	9.5ms
1.00in (2.54mm) or 1.63in (41.3mm)	9Gbyte	Yes	7200	9.5ms
1.63in (41.3mm)	18Gbyte	Yes	7200	9.5ms

A.6.2 Optional CD-ROM Drive

The CD-ROM drive is a standard device with multimedia features. This includes multi-session capability and fast access (12x) for image and video data. The CD-ROM drive dimensions are 149.5mm (5.94in) x 196mm (7.78in) x 43mm (1.71in) and the drive slot is a standard 1.6-in (40.64mm) bay that uses industry standard bezels.

The CD-ROM drive supports an approximate data transfer rate of 600Kb/s and an access time of 350ms (maximum). The *SunCD 12X Installation and User's Guide*, document part number 805-0940, provides cleaning, jumper setting and operation instructions for the CD-ROM drive.

An optional 32x CD-ROM drive is also supported.

A.6.3 Optional 2.5Gbyte, 4mm and 8mm Tape Drives

The system unit supports the optional 2.5Gbyte, 4mm or 8mm tape drives.

A.6.3.1 2.5Gbyte Tape Drive

The 2.5Gbyte tape drive is a 1/4in tape drive equipped with an intelligent controller and an embedded SCSI-type interface. The *2.5-Gbyte QIC Tape Drive Specifications*, part number 802-3615, provides cleaning, jumper setting and tape cartridge instructions for the 2.5Gbyte tape drive.

A.6.3.2 4mm Tape Drive

The 4mm tape drive is equipped with a single-ended SCSI controller and a 1Mbyte on-drive buffer. The *DDS-2 Tape Drive Specifications*, part number 802-5324, provides cleaning, jumper setting and tape cartridge instructions for the 4mm DDS-2 tape drive. The *DDS-3 Tape Drive Specifications*, part number 802-7791, provides cleaning, jumper setting and tape cartridge instructions for the 4mm DDS-3 tape drive.

A.6.3.3 8mm Tape Drive

The 8mm tape drive is an enhanced 8mm digital helical-scan cartridge tape subsystem. It is packaged in the industry standard 5.25-inch half-height form factor. The *8-mm Tape Drive Specifications*, part number 802-5775, provides cleaning, jumper setting and tape cartridge instructions for the 8mm tape drive.

A.7 Parallel Port

The parallel port is supported by an IEEE 1284-compatible parallel port controller located on the SuperIO ASIC. The parallel port controller is an industry standard controller that achieves a 2-megabits per second (Mbps) data transfer rate. The parallel port controller interface supports the ECP protocol as well as the following:

- Centronics – Provides a widely accepted parallel port interface.
- Compatibility – Provides an asynchronous, byte-wide forward (host to peripheral) channel with data and status lines used according to their original definitions.
- Nibble mode – Provides an asynchronous, reverse (peripheral-to-host) channel, under control of the host. Data bytes are transmitted as two sequential, four-bit nibbles using four peripheral-to-host status lines.

A.7.1 Parallel Port Cables

The parallel port cable is IEEE1284 compliant and consists of 18 pairs of signal wires that are double shielded with braid and foil. The maximum length of the parallel port cable is 2m.

A.7.2 Electrical Characteristics

Drivers operate at a nominal 5Vdc transistor-transistor logic (TTL) levels. The maximum open circuit voltage is 5.5Vdc and the minimum is -0.5Vdc. A logic high-level signal is at least 2.4Vdc at a source current of 0.32mA and a logic low-level signal is no more than 0.4Vdc at a sink current of 14mA.

Receivers also operate at nominal -5Vdc TTL levels and can withstand peak voltage transients between -2Vdc and 7Vdc without damage or improper operation. The high-level threshold is less than or equal to 2.0Vdc and the low-level threshold is at least 0.8Vdc. Sink current is less than or equal to 0.32mA at 2.0Vdc and source current is less than or equal to 12mA at 0.8Vdc.

A.8 Serial Port

The system unit incorporates two serial ports, each of which is synchronous and asynchronous with full modem controls. All serial port functions are controlled by a serial port controller that is electrically connected to the system through the EBus. Line drivers and line receivers control the serial port signal levels and provide RS232 and RS423 compatibility. Each serial port interfaces through its own DB-25 connector.

The major features of each serial port include:

- Two fully-functional synchronous and asynchronous serial ports
- DB-25 connectors
- Increased baud rate speed (to 384Kbaud synchronous, 460.8Kbaud asynchronous)
- Variable edge rate for greater performance
- EBus interface.

FIGURE A-11 shows a functional block diagram of the serial ports.

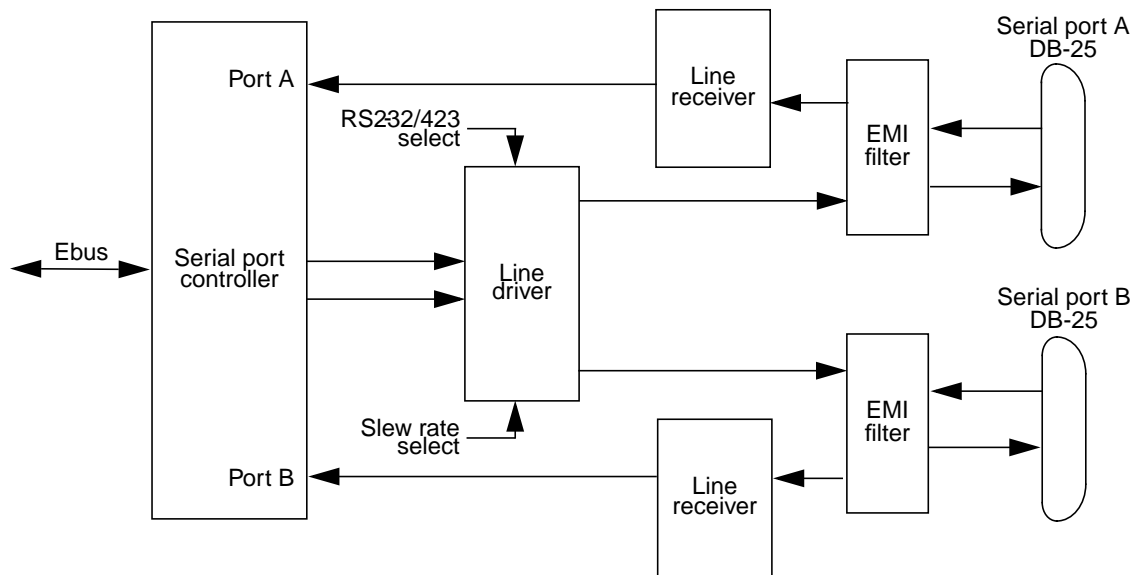

FIGURE A-11 Serial Port Functional Block Diagram

A.8.1 Serial Port Components

Serial port components include a serial port controller, line drivers and the line receivers.

The serial port controller contains 64-byte buffers on both the input and output. This enables the serial port to require less CPU bandwidth. Interrupts are generated when the buffer reaches 32 bytes or half full. The serial port controller contains its own crystal oscillator that supports rates of up to 921.6Kbaud.

The line drivers and line receivers are compatible with both RS232 and RS423. Two system board jumpers are used to set the line drivers and line receivers to either RS232 or RS423 protocols. The line driver slew rate is also programmable. For baud rates over 100K, the slew rate is set to 10Vdc/s. For baud rates under 100K, the slew rate is set to 5Vdc/s.

A.8.2 Serial Port Functions

The serial port provides a variety of functions. Modem connection to the serial port allows access to the Internet. An ASCII text window is accessible through the serial port on non-graphic systems. The additional speed of the serial port can be used to execute communications with a CSU/DSU for a partial T1 line to the Internet at 384Kbaud.

A.8.3 EIA Levels

Each serial port supports both RS232 and RS423 protocols. RS232 signaling levels are between -3Vdc and -15Vdc and $+3\text{Vdc}$ and $+15\text{Vdc}$. A binary 1 (001_2) is anything greater than $+3\text{Vdc}$ and a binary 0 (000_2) is anything less than -3Vdc . The signal is undefined in the transition area between -3Vdc and $+3\text{Vdc}$. The line driver switches at -10Vdc and $+10\text{Vdc}$ with a maximum of -12Vdc and $+12\text{Vdc}$ in RS232 mode. RS423 is similar except that signaling levels are between -4Vdc and -6Vdc and $+4\text{Vdc}$ and $+6\text{Vdc}$. The line driver switches at -5.3Vdc and $+5.3\text{Vdc}$ with a maximum of -6Vdc and $+6\text{Vdc}$. Switching from RS232 to RS423 protocol is accomplished by changing jumpers J2604 and J2605. Jumper positions 1 and 2 are for RS232 and jumper positions 2 and 3 are for RS423 (see Section 5.3 "Serial Port Jumpers" on page 5-3).

The preferred signaling protocol is RS423. The higher voltages of RS232 make it difficult to switch at the higher baud rates. The maximum rate for RS232 is approximately 64Kbaud while the maximum rate for RS423 is 460.8 Kbaud. The system default is set to RS232.

A.8.3.1 Synchronous Rates

The serial synchronous ports operate at any rate from 50Kbaud to 256Kbaud when the clock is generated from the serial port controller. When the clock is generated from an external source, the synchronous ports operate at up to 384Kbaud. Clock generation is accurate within 1 percent for any rate that is generated between 50Kbaud and 256Kbaud.

A.8.3.2 Asynchronous Rates

The serial asynchronous ports support 20 baud rates that are all exact divisors of the crystal frequency (with exception of 110, which is off by less than 1 percent). Baud rates include 50, 75, 110, 200, 300, 600, 1200, 1800, 2400, 4800, 9600, 19200, 38400, 57600, 76800, 115200, 153600, 230400, 307200 and 460800.

A.8.3.3 Slew Rate and Cable Length

The maximum cable length is 30m. The slew rate changes depending on the speed. For speeds less than 100Kbaud, the slew rate is set at 5Vdc/ms. For rates greater than 100Kbaud, the slew rate is increased to 10Vdc/ms. This allows maximum performance for the greater baud rates and better signal quality at the lesser baud rates.

A.9 Ethernet

The system unit supports 10Mbps, 10BASE-T, twisted-pair Ethernet and 100Mbps, 100BASE-X, media independent interface (MII) Ethernet with the use of a single magnetics module. Twisted-pair Ethernet is provided through an 8-pin RJ45 connector. MII Ethernet is provided through a 40-pin MII connector. The MII port allows connection to any cable medium, including shielded twisted-pair (STP), and fiber optic accompanied by the appropriate external transceiver. The system automatically senses an external transceiver, thus disabling an on-board transceiver.

The Ethernet circuitry design is based on two National Semiconductor ICs: the DP83840 (PHY) IC and the DP83223 (Twister) IC.

The PHY chip integrates a 100BASE-T physical coding sub-layer (PCS) and a complete 10BASE-T module in a single chip. It provides a standard MII to communicate between the physical signaling and the medium access control layers for both 100BASE-X and 10BASE-T operations. The PHY IC interfaces to the 100Mbps physical-medium-dependent transceiver Twister IC.

The 100BASE-X portion of the PHY IC consists of the following functional blocks:

- Transmitter
- Receiver
- Clock generation module
- Clock recovery module.

The 10BASE-T section of the PHY IC consists of the 10Mbps transceiver module with filters.

The 100BASE-T transceiver is included in a separate Twister IC and features adaptive equalization, baseline wander correction and transition time control on the output signals.

The 100BASE-X and 10BASE-T sections share the following functional characteristics:

- PCS control
- MII registers
- IEEE 1149.1 controller (JTAG compliance)
- IEEE 802.3u auto negotiation.

The following sections provide brief descriptions of the following:

- Automatic negotiation
- External transceivers
- External cables
- Connectors
- MII power
- MII port timing.

A.9.1 Automatic Negotiation

Automatic negotiation controls the cable when a connection is established to a network device. It detects the various modes that exist in the linked partner and advertises its own abilities to configure automatically the highest performance mode of inter-operation, namely, 10BASE-T, 100BASE-TX, or 100BASE-T4 in half- and full-duplex modes.

The Ethernet port supports automatic negotiation. At power up, an on-board transceiver advertises 100BASE-TX in half-duplex mode, which is configured by the automatic negotiation to the highest common denominator based on the linked partner.

A.9.2 External Transceivers

The following external transceivers are connected through the MII port:

- 6211 Micro 100BASE-FX FastEthernet transceiver
- CT4-1030 100BASE-T4 transceiver
- CFX-107X 100BASE-FX transceiver
- XF467A MII-to-AUI transceiver.

A.9.3 External Cables

The MII port supports a 0.5m, 40-conductor, 20 signal-ground, STP cable. The single-ended impedance of the cable is 68Ω ($\pm 10\%$). The propagation delay for each twisted-pair, measured from the MII connector to the PHY, does not exceed 2.5ns.

The RJ45 Ethernet port supports a Category 5 UTP cable for the 100BASE-T, and a Category 3, 4, or 5 UTP cable for the 10BASE-T operation.

Note – The maximum cable segment lengths for the 100BASE-TX and 10BASE-TX are 100m and 1000m, respectively.

A.9.4 Connectors

A 40-pin connector is used for the MII connector. A standard 8-pin RJ45 connector with a shield is used for the AUI connector.

A.9.5 MII Power

A regulated 5Vdc (5%) voltage is supplied to the PHY IC over the load range from 0 to 750mA. A 2A overcurrent protection circuit is provided by a polymer-based resettable fuse to the MII supply voltage.

MII-to-AUI connection to a 10Mbps medium attachment unit requires a supplemental power source to meet the AUI power supply requirements. The MII-AUI converter provides the necessary supplemental power.

A.9.6 MII Port Timing

MII port timing encompasses two configurations involving the use of either an on-board transceiver or external transceivers. For either transceiver configuration, the MII port timing is the same because MII operates with a 40ns cycle time.

FIGURE A-12 illustrates MII being used to interconnect both integrated circuits and circuit assemblies. This enables separate signal transmission paths to exist between the reconciliation sublayer, (embedded in the PCIO ASIC), and a local PHY IC, and between the reconciliation sublayer and a remote PHY IC. The unidirectional paths between the reconciliation sublayer and the local PHY IC are composed of sections A1, B1, C1 and D1. The unidirectional paths between the reconciliation sublayer and the remote PHY IC are composed of sections A2, B2, C2 and D2.

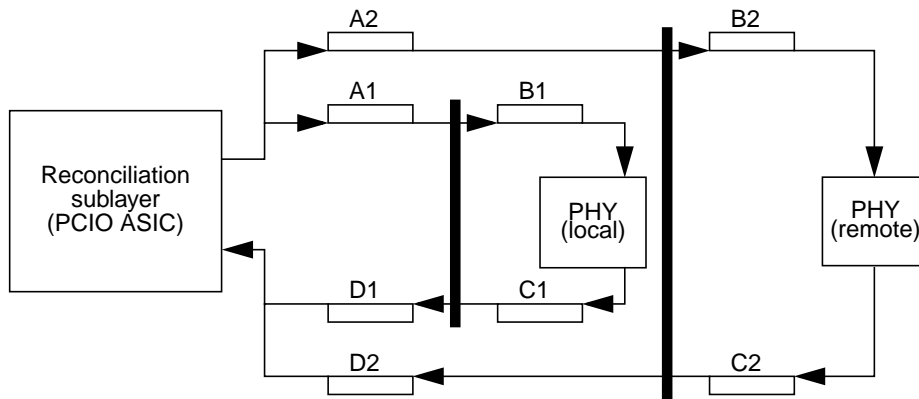

FIGURE A-12 MII Port Timing Model

A.10 Alarms Card

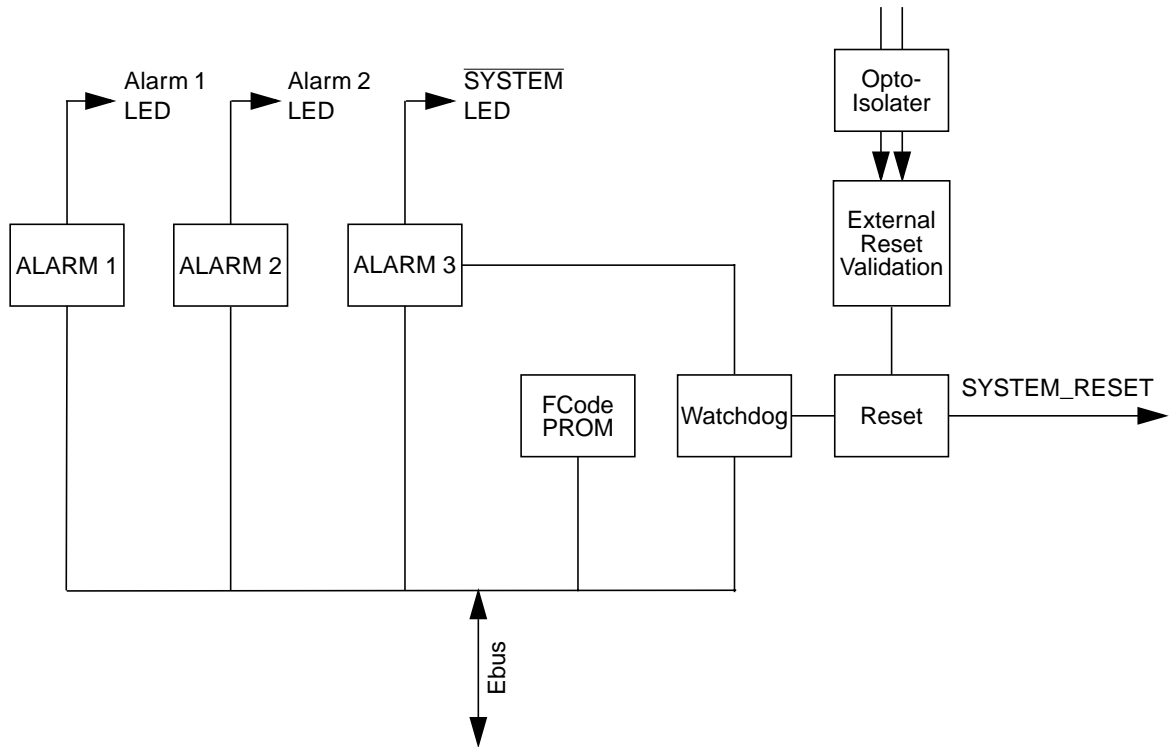

FIGURE A-13 Alarms Card Functional Block Diagram

A.11 Ebus Connector

The motherboard connector is an AMP Connector Assembly, Dual Position, 0.050 Series, Standard Edge. Amp Part No. 650090-7. TABLE A-5 lists the Ebus Connector pin-outs.

TABLE A-5 Ebus Connector Pinouts

Pin	Signal	Pin	Signal
1	Gnd	24	VCC
2	Gnd	25	PROM-CS/
3	N/A	26	RESET/
4	N/A	27	AUD-CS/
5	Spare	28	N/A
6	Gnd	29	Gnd
7	Gnd	30	WR/
8	N/A	31	D6
9	+12V	32	RD/
10	-12V	33	D4
11	+12V	34	D7
12	AUDIO_PRESENT	35	D2
13	LA8	36	D5
14	Gnd	37	D0
15	A6	38	D3
16	A7	39	Gnd
17	Gnd	40	D1
18	A5	41	CDAK/
19	A4	42	Gnd
20	A3	43	PDAK/
21	A2	44	CDRQ
22	A1	45	PDWN/
23	A0	46	PDRQ

A.12 SCSI

The system unit implements a small computer system interface (SCSI)-3 Fast-20 parallel interface (Fast-20) bus. The Fast-20 is based on SCSI-3 parallel interface and provides the following:

- Efficient peer-to-peer I/O bus devices
- Definition of the mechanical, electrical, and timing specification to support transfer rates of 20, 40, or 80Mbyte/s corresponding to the data path width of an 8-, 16-, or 32-bit bus, respectively.

Fast-20 is also called wide SCSI and the two names are used synonymously.

The SCSI subsystem is based upon single-ended Fast-20 using a 16-bit-wide bus. Fast-20, having an implemented 16-bit bus width, supports a peak bandwidth of 40 Mbyte/s.

The maximum cumulative signal path length between terminators is 3m when connecting up to four external devices (one host initiator and three targets). The maximum cumulative signal path length between terminators is 1.5m when using from five to eight external devices (one host initiator and four to seven targets).

The system incorporates a dual-channel host adapter. One channel is used exclusively to provide an internal SCSI bus, and the second provides the external SCSI bus. The internal bus is terminated at one end on the motherboard and at the other on the CD-ROM adapter. The external bus is terminated at the host adapter and at the 68-pin external connector. Connecting an external device disables the on-board terminators near the 68-pin connector to extend the bus and allowing the last external device to provide the termination. FIGURE A-14 shows the SCSI bus configuration.

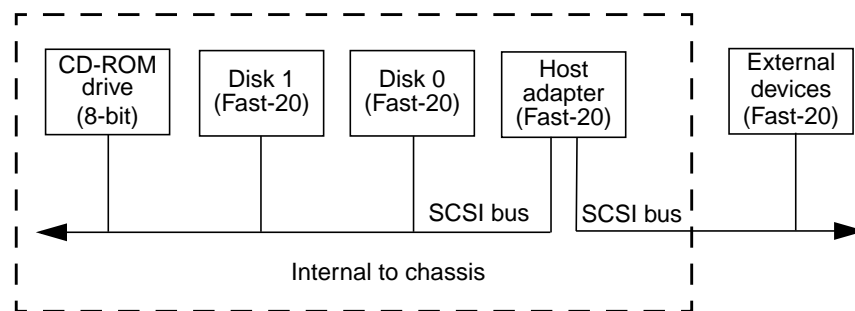

FIGURE A-14 Configuration for the SCSI Bus

A.12.1 Host Adapter

The host adapter is a dual-channel Symbios 53C876 PCI-SCSI I/O processor IC. The host adapter and all target devices comply with the Fast-20 single-ended drivers and receivers characteristics. The electrical characteristics of the output buffers include:

- V_{OL} (output low) equals 0 to 0.5Vdc with I_{ol} at 48mA (signal asserted)
- V_{OH} (output high) equals 2.5 to 3.7Vdc (signal negated)
- t_{rise} (rising slew rate) equals 520mV/ns maximum (0.7 to 2.3Vdc)
- t_{fall} (falling slew rate) equals 520mV/ns maximum (2.3 to 0.7Vdc).

The Fast-20 electrical characteristics for the host adapter and target device include:

- V_{IL} (input low) equals 1.0Vdc maximum (signal true)
- V_{IH} (input high) equals 1.9Vdc minimum (signal false)
- I_{IL} (input low current) equals $\pm 20\mu A$ at V_i equals 0.5Vdc
- I_{IH} (input high current) equals $\pm 20\mu A$ at V_i equals 2.7Vdc
- Minimum input hysteresis equals 0.3Vdc

A.12.2 Supported Target Devices

The CD-ROM drive is a narrow device. A unipack with one drive or a six-pack, accommodating six drives, can be used as external devices. TABLE A-6 lists the target devices supported by the SCSI subsystem.

TABLE A-6 SCSI Devices Supported

Target Device	Comment
Internal disks	Up to two 3.5in x 1.6in disks (2.1, 4.2 or 9.1Gbyte). All internal disks are Fast-20-compliant.
Internal CD-ROM drive	Optional 644Mbyte SunCD 12x or 32x speed; photo CD compatible. Headphone jack with volume control. CD-ROM drive is a narrow SCSI device.
Internal tape drive	Optional 4Gbyte DDS2 4mm, supporting narrow SCSI; optional 20Gbyte 8mm, supporting wide SCSI.
External SPARCstorage UniPack	Disk 2.1 or 4.2Gbyte, Fast-20 compliant.
External SPARCstorage SixPack	Disk 2.1 or 4.2Gbyte, Fast-20 compliant.

A.12.3 External Cables

External Fast-20 compliant SCSI cables are an extension of the existing shielded cables but have a impedance of $90\Omega (\pm 6\Omega)$. Fast-20 requires that the total SCSI bus length be limited to 3m for less than five devices and 1.5m for five to eight devices.

A.12.4 Internal SCSI Subassembly

The internal SCSI subassembly consists of two cable assemblies and two SCSI cards. The SCSI subassembly is attached to the motherboard using an insulation displacement connector (IDC) receptacle attached to an 80-conductor cable. The IDC receptacle mates with a right angle plug mounted on the motherboard in close proximity to the test edge connector.

The 80-conductor cable attaches on the other end to the SCSI backplane card with another IDC connector. The SCSI backplane card incorporates two SCA-2 connectors for mounting the hard drives and a four-circuit power connector to supply 5Vdc and 12Vdc power to the hard drives.

A 68-conductor cable exits the SCSI backplane card, carrying 27 SCSI signals and the Termpower to the internal CD-ROM drive (or tape drive). The QCD card houses the CD-ROM drive connector and three SCSI bus terminators. The Termpower is routed through the SCSI subassembly to connect to the terminators on the QCD card in support of the multi-host configuration. FIGURE A-15 shows the internal SCSI subassembly.

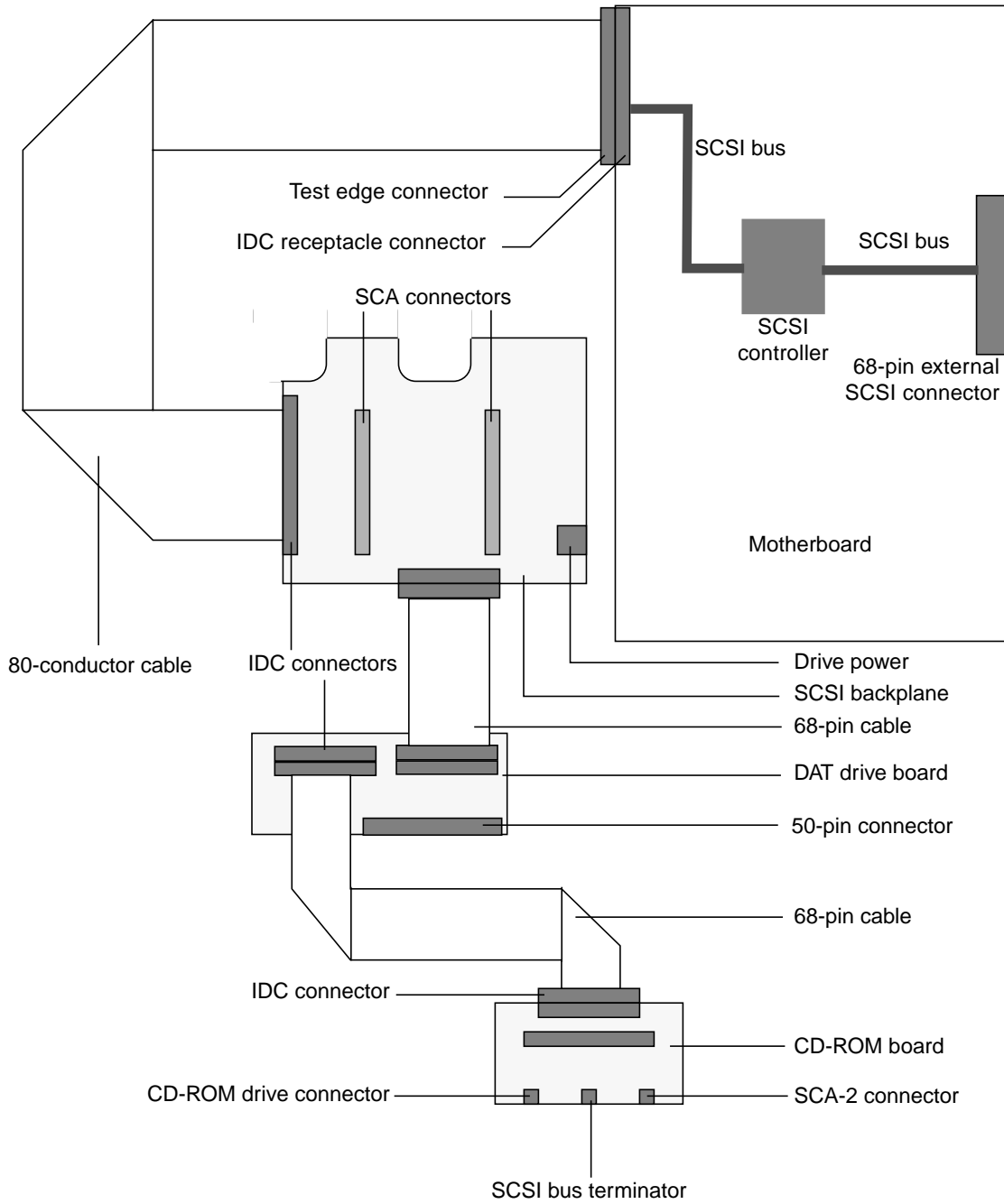

FIGURE A-15 SCSI Sub-Assembly Block Diagram

A.12.5 SCSI ID Selection

The motherboard host adapter is assigned the SCSI identification of 7. The two internal drives attached to the SCA-2 connectors have a SCSI identification of 0 and 1, while the CD-ROM has an identification of 6 and the tape drive has an identification of 5.

A.13 ASICs

The system unit achieves a high level of integration through application-specific integrated circuits (ASICs). All ASICs are 1149.1 (JTAG) compliant. The ASICs are:

- QSC
- XB9+
- PCI-to Ebus/Ethernet controller (PCIO)
- UPA-to-PCI bridge (U2P)
- Reset, interrupt, scan and clock (RISC).

Also included in this section is a brief discussions of the SuperIO component.

A.13.1 QSC

The QSC ASIC provides system control. It controls the UPA interconnect between the major system unit components and main memory. The QSC ASIC provides the following:

- Interconnect packet receive
- Memory arbiter
- Non-cached arbiter
- Memory controller
- Snoop interface
- Coherence controller
- S_register dispatcher
- Internet packet send
- Datapatch scheduler
- EBus interface.

A.13.2 XB9+

The XB9+ ASIC is a buffered memory crossbar device that acts as the bridge between the six system unit buses. The six system unit buses include two processor buses, a memory data bus and two I/O buses. The XB9+ ASIC provides the following:

Note – Referred data formats are as follows: a byte is 8 bits, a halfword is 16 bits, a word is 32 bits, and a doubleword is 64 bits.

- Six-port crossbar
- Decoupled memory port; loading and unloading of memory data can take place in parallel with other operations
- Burst transfers operate on a doubleword of data per slice
- A total of eight two-entry first-in-first-out (FIFO) devices for read data storage
- Power-up safe buses (tristated).

A.13.3 PCIO

The PCI-to-Ebus2/Ethernet controller (PCIO) ASIC performs dual roles: PCI bus-to-Ebus2 bridging and Ethernet control. The PCIO ASIC provides the electrical connection between the PCI bus and all other I/O functions. In addition, the PCIO ASIC also contains an embedded Ethernet controller to manage Ethernet transactions and provides the electrical connection to slower on-board functions, such as the Flash PROM and the alarms module.

A.13.4 U2P

The UPA-to-PCI bridge (U2P) ASIC provides an I/O connection between the UPA bus and the two PCI buses. The U2P ASIC features include:

- Full master and slave port connection to the high-speed UPA interconnect. The UPA is a split address/data packet-switched bus that has a potential data throughput rate greater than 1Gbyte/s. UPA data is ECC protected.
- Two physically separate PCI bus segments with full master and slave support:
 - 66MHz PCI bus segment (PCI bus A): 3.3Vdc signalling, 64-bit data bus, compatible with the PCI 66MHz extensions, support for up to four master devices (at 33MHz only)
 - 33MHz PCI bus segment (PCI bus B): 5.0Vdc signaling, 64-bit data bus, support for up to six master devices

- Two separate 16-entry streaming caches, one for each bus segment, for accelerating some kinds of PCI DVMA activity. Single IOMMU with 16-entry TLB for mapping DVMA addresses for both bus (IOMMU used to translate 32- or 64-bit PCI addresses into 41-bit UPA addresses).
- A mono-vector dispatch unit for delivering interrupt requests to the CPU module, including support for PCI interrupts from up to six slots, as well as interrupts from on-board I/O devices.

A.13.5 RISC

The reset, interrupt, scan, and clock (RISC) ASIC implements those four functions. Generation and stretching of the reset pulse is performed in this ASIC. Interrupt logic concentrates 42 different interrupt sources into a 6-bit code that communicates with the U2P ASIC. It also integrates a JTAG controller.

The RISC ASIC features include:

- Determination of system clock frequency
- Control of reset generation
- Provision of JTAG
- Performance of PCI bus and miscellaneous interrupt concentration for U2P
- Control of flash PROM programming, frequency margining and lab console operation
- 33MHz operation
- 160-pin MQFP package
- 3.3Vdc and 5Vdc supply voltage.

A.13.6 SuperIO

The SuperIO is a commercial off-the-shelf component that contains two serial port controllers.

A.14 Power Supply

A.14.1 Netra t 1120

The system unit uses a power supply that operates in the voltage range of -40 to -75 Vdc. The maximum input current is 15A and the inrush current is limited to 60 peak amps.

The power supply output voltages are listed in TABLE A-7. The power supply continues to regulate all outputs for approximately 13ms after DC input power is removed.

TABLE A-7 DC Power Supply Output Voltages

Output	Voltage (Vdc)	Max Current (A)	Regulation Band
1	3.3	50.0	3.23 to 3.43
2	5.0	35.0	4.85 to 5.25
3	12.0	6.0	11.65 to 12.6
4	-12.0	1.0	-12.6 to -11.4
5	2.5 to 3.5	28.0	$\pm 2\%$

Note – The combined power of output 1 and output 2 is less than 280W.

A.14.2 Netra t 1125

The power supply output voltages are listed in TABLE A-8. The power supply continues to regulate all outputs for approximately 13ms after AC input power is removed.

TABLE A-8 AC Power Supply Output Voltages

Output	Voltage (Vdc)	Max Current (A)	Regulation Band
1	3.3	50.0	3.23 to 3.43
2	5.0	35.0	4.85 to 5.25
3	12.0	6.0	11.65 to 12.6
4	-12.0	1.0	-12.6 to -11.4
5	2.5 to 3.5	28.0	±2%

Note – The combined power of output 1 and output 2 is less than 280W.

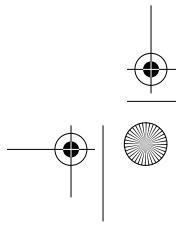
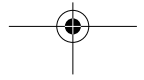
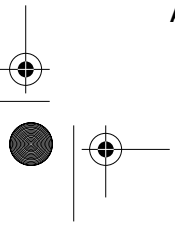
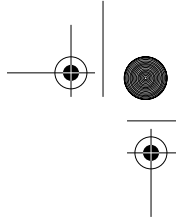

Index

NUMERICS

10BASE-T, 3-1
2.5Gbyte tape drive, A-13
4mm tape drive, A-13
8mm tape drive, A-13

A

address bus, A-4
alarms card, A-21
 connector, 2-10
 functional block diagram, A-21
alarms port, 2-10
antistatic precautions, 1-10
ASICs
 PCIO, A-28
 QSC, A-6, A-28
 RISC, A-29
 SuperIO, A-29
 U2P, A-28
 XB9+, A-6, A-28
asynchronous rates, A-17
automatic negotiation, A-18

B

back panel layout, 2-1

C

cable lengths

MII, 2-4
serial port, A-17
slew rate, A-17
STP-5, 2-5

cables

external lengths, 2-4
MII, 2-4
SCSI, 2-8

CD-ROM drive, A-12

circuit breaker

activating, 1-5
external, 1-5

clock control, A-29

connectivity

TPE, 2-5

connectors

alarms card, 2-10
Ebus, A-22
layout, 2-1
MII, 2-3
parallel, 2-11
SCSI, 2-6
serial, 2-2
TPE, 2-5

CPU module timing, A-10, A-11

D

data flow regulation, A-28

disk drive

capacity, A-12
supported, A-12

DRAM SIMM, *See* SIMM

E**Ebus**

- connector, A-22
- pinouts, A-22

EIA levels, A-16**Ethernet, 3-1, A-17**

- 10BASE-T twisted-pair, 3-1
 - automatic negotiation, A-18
 - cable connectivity, 2-4
 - connectors, A-19
 - control, A-28
 - external cables, A-19
 - external transceivers, A-19
 - MII port timing, A-20
 - MII power, A-19
 - TPE connectivity, 2-5
 - TPE connector, 2-5
 - troubleshooting, 3-4
 - twisted-pair link integrity test, 3-4
- external cable**
- lengths, 2-5
- external cables, A-19**
- external transceivers, A-19**

F**flash PROM**

- control, A-29
- jumpers, 5-3

I

- IEEE 10BASE-T specification, 3-1
- interrupt logic, A-29

J**JTAG controller, A-29****jumpers, 5-1**

- flash PROM, 5-3
- identifying, 5-2
- serial port, 5-3
- settings, 5-1
- user-configurable, 5-2

L**link test**

- description, 3-4
- enable, 3-6
- performing, 3-5

M**main logic board jumpers, 5-1****Media Independent Interface, See MII****memory**

- functional block diagram, A-6
- module, A-8
- system timing, A-10

memory system, A-6**MII**

- connector, 2-3
- port timing, A-20
- port timing model, A-20
- power, A-19

modem

- cable, 4-2
- setup, 4-1
- switch settings, 4-2

O

- ON/STBY switch, 1-5, 1-6
- operating system halt, 1-6

P**parallel port, A-14**

- cables, A-14
- connector, 2-11
- electrical characteristics, A-14
- pin configuration, 2-11

PCI bus, A-4**PCIO ASIC, A-5, A-28****peripherals, A-12****CD-ROM drive, A-12****tape drive**

- 2.5Gbyte, A-13
- 4mm, A-13
- 8mm, A-13

pinouts

- alarms card connector, 2-10
- Ebus connector, A-22
- MII connector, 2-3
- parallel connector, 2-11
- SCSI connector, 2-6
- serial connector, 2-2
- TPE connector, 2-5
- Power LED, 1-6
- power supply
 - output voltages, A-30, A-31
- power-off, 1-6
- power-on, 1-5

Q

- QSC ASIC, A-6, A-28

R

- request flow regulation, A-28
- reset pulse generation, A-29
- RISC ASIC, A-29

S

- SCSI, A-23
 - cabling, 2-8
 - cabling procedure, 2-8
 - configuration, 2-8
 - connector, 2-6
 - controller, A-5
 - external cables, A-25
 - host adapter, A-24
 - implementation, 2-7
 - internal sub-assembly, A-25
 - SCSI-2 devices, 2-9
 - sub-assembly, A-25
 - sub-assembly functional block diagram, A-26
 - supported target devices, A-24
- serial port, A-15
 - asynchronous rates, A-17
 - cable length, A-17
 - components, A-16
 - connectors, 2-2
 - controller, A-29
 - EIA levels, A-16

- functional block diagram, A-15
- functions, A-16
- jumpers, 5-3
- slew rate, A-17
- speed change, 4-2
- synchronous rates, A-17
- SIMM, A-6
 - bank-to-U-number mapping, A-9
 - configuration, A-9
 - mapping, A-9
 - physical address mapping
 - IL = 0, A-9
- SuperIO ASIC, A-29
- synchronous rates, A-17
- system
 - back panel, 2-1
 - clock control, A-29
 - controller uniprocessor, A-6, A-28
 - description, A-1
 - features, 1-2
 - front view, 1-3
 - functional block diagram, A-2
 - power-off, 1-6
 - power-on, 1-5
 - rear view, 1-4

T

- tape drive
 - 2.5Gbyte, A-13
 - 4mm, A-13
 - 8mm, A-13
- 10BASE-T, 3-1
- testing
 - Ethernet twisted-pair, 3-4
- timing
 - CPU module, A-10, A-11
 - memory system, A-10
- top cover
 - removing, 1-10
 - replacing, 1-12
- TPE connector, 2-5
- troubleshooting
 - Ethernet, 3-4
- Twisted-Pair Ethernet, *See* TPE

U

U2P ASIC, A-4, A-28

UltraSPARC II processor, A-5

UltraSPARC Port Architecture, *See* UPA

UPA, A-3

address bus functional block diagram, A-4

addressing, A-3

client resets, A-28

data bus, A-4

data bus functional block diagram, A-4

port identification assignments, A-3

W

wrist strap attachment, 1-7

X

XB9+ ASIC, A-6, A-28