



# Sun Fire™ E25K/E20K Systems

---

## Overview

Sun Microsystems, Inc.  
www.sun.com

Part No. 817-4136-11  
April 2004, Revision A

Submit comments about this document at: <http://www.sun.com/hwdocs/feedback>

Copyright 2004 Sun Microsystems, Inc., 4150 Network Circle, Santa Clara, California 95054, U.S.A. All rights reserved.

Sun Microsystems, Inc. has intellectual property rights relating to technology that is described in this document. In particular, and without limitation, these intellectual property rights may include one or more of the U.S. patents listed at <http://www.sun.com/patents> and one or more additional patents or pending patent applications in the U.S. and in other countries.

This document and the product to which it pertains are distributed under licenses restricting their use, copying, distribution, and decompilation. No part of the product or of this document may be reproduced in any form by any means without prior written authorization of Sun and its licensors, if any.

Third-party software, including font technology, is copyrighted and licensed from Sun suppliers.

Parts of the product may be derived from Berkeley BSD systems, licensed from the University of California. UNIX is a registered trademark in the U.S. and in other countries, exclusively licensed through X/Open Company, Ltd.

Sun, Sun Microsystems, the Sun logo, AnswerBook2, docs.sun.com, Sun Fire, Sun Fireplane interconnect, Netra, and Solaris are trademarks or registered trademarks of Sun Microsystems, Inc. in the U.S. and in other countries.

All SPARC trademarks are used under license and are trademarks or registered trademarks of SPARC International, Inc. in the U.S. and in other countries. Products bearing SPARC trademarks are based upon an architecture developed by Sun Microsystems, Inc.

The OPEN LOOK and Sun™ Graphical User Interface was developed by Sun Microsystems, Inc. for its users and licensees. Sun acknowledges the pioneering efforts of Xerox in researching and developing the concept of visual or graphical user interfaces for the computer industry. Sun holds a non-exclusive license from Xerox to the Xerox Graphical User Interface, which license also covers Sun's licensees who implement OPEN LOOK GUIs and otherwise comply with Sun's written license agreements.

U.S. Government Rights—Commercial use. Government users are subject to the Sun Microsystems, Inc. standard license agreement and applicable provisions of the FAR and its supplements.

DOCUMENTATION IS PROVIDED "AS IS" AND ALL EXPRESS OR IMPLIED CONDITIONS, REPRESENTATIONS AND WARRANTIES, INCLUDING ANY IMPLIED WARRANTY OF MERCHANTABILITY, FITNESS FOR A PARTICULAR PURPOSE OR NON-INFRINGEMENT, ARE DISCLAIMED, EXCEPT TO THE EXTENT THAT SUCH DISCLAIMERS ARE HELD TO BE LEGALLY INVALID.

---

Copyright 2004 Sun Microsystems, Inc., 4150 Network Circle, Santa Clara, Californie 95054, Etats-Unis. Tous droits réservés.

Sun Microsystems, Inc. a les droits de propriété intellectuels relatants à la technologie qui est décrit dans ce document. En particulier, et sans la limitation, ces droits de propriété intellectuels peuvent inclure un ou plus des brevets américains énumérés à <http://www.sun.com/patents> et un ou les brevets plus supplémentaires ou les applications de brevet en attente dans les Etats-Unis et dans les autres pays.

Ce produit ou document est protégé par un copyright et distribué avec des licences qui en restreignent l'utilisation, la copie, la distribution, et la décompilation. Aucune partie de ce produit ou document ne peut être reproduite sous aucune forme, par quelque moyen que ce soit, sans l'autorisation préalable et écrite de Sun et de ses bailleurs de licence, s'il y en a.

Le logiciel détenu par des tiers, et qui comprend la technologie relative aux polices de caractères, est protégé par un copyright et licencié par des fournisseurs de Sun.

Des parties de ce produit pourront être dérivées des systèmes Berkeley BSD licenciés par l'Université de Californie. UNIX est une marque déposée aux Etats-Unis et dans d'autres pays et licenciée exclusivement par X/Open Company, Ltd.

Sun, Sun Microsystems, le logo Sun, AnswerBook2, docs.sun.com, Sun Fire, Sun Fireplane interconnect, Netra, et Solaris sont des marques de fabrique ou des marques déposées de Sun Microsystems, Inc. aux Etats-Unis et dans d'autres pays.

Toutes les marques SPARC sont utilisées sous licence et sont des marques de fabrique ou des marques déposées de SPARC International, Inc. aux Etats-Unis et dans d'autres pays. Les produits portant les marques SPARC sont basés sur une architecture développée par Sun Microsystems, Inc.

L'interface d'utilisation graphique OPEN LOOK et Sun™ a été développée par Sun Microsystems, Inc. pour ses utilisateurs et licenciés. Sun reconnaît les efforts de pionniers de Xerox pour la recherche et le développement du concept des interfaces d'utilisation visuelle ou graphique pour l'industrie de l'informatique. Sun détient une licence non exclusive de Xerox sur l'interface d'utilisation graphique Xerox, cette licence couvrant également les licenciées de Sun qui mettent en place l'interface d'utilisation graphique OPEN LOOK et qui en outre se conforment aux licences écrites de Sun.

LA DOCUMENTATION EST FOURNIE "EN L'ÉTAT" ET TOUTES AUTRES CONDITIONS, DECLARATIONS ET GARANTIES EXPRESSES OU TACITES SONT FORMELLEMENT EXCLUES, DANS LA MESURE AUTORISEE PAR LA LOI APPLICABLE, Y COMPRIS NOTAMMENT TOUTE GARANTIE IMPLICITE RELATIVE A LA QUALITE MARCHANDE, A L'APTITUDE A UNE UTILISATION PARTICULIERE OU A L'ABSENCE DE CONTREFAÇON.

# Contents

---

**Declaration of Conformity** xi

**Preface** xiii

- 1. Sun Fire E25K/E20K Systems Introduction** 1-1
  - 1.1 System Boards 1-2
    - 1.1.1 CPU/Memory Boards 1-2
    - 1.1.2 I/O Boards 1-3
    - 1.1.3 System Controller 1-3
    - 1.1.4 Peripherals 1-3
  - 1.2 System Configuration 1-4
  - 1.3 System Interconnects 1-5
    - 1.3.1 Sun Fireplane Interconnect Architecture 1-6
    - 1.3.2 Address Interconnect 1-7
    - 1.3.3 Data Interconnect 1-7
  - 1.4 Dynamic System Domains 1-8
  - 1.5 Reliability, Availability, and Serviceability 1-9
    - 1.5.1 Integrated Circuit Reliability 1-9
    - 1.5.2 Interconnect Reliability 1-9
    - 1.5.3 Fault-Tolerant Redundancy 1-10

- 1.5.4 Reconfiguration After Failure 1-10
- 1.5.5 Serviceability 1-10
  
- 2. Dynamic System Domains 2-1**
  - 2.1 Domain Configurability 2-1
  - 2.2 Domain Protection 2-3
  - 2.3 Domain Fault Isolation 2-3
  
- 3. Reliability, Availability, and Serviceability 3-1**
  - 3.1 SPARC CPU Error Protection 3-1
  - 3.2 System Interconnect Error Protection 3-3
    - 3.2.1 Address Interconnect Error Protection 3-3
    - 3.2.2 Data Interconnect Error Protection 3-3
    - 3.2.3 Data Interconnect Error Isolation 3-4
    - 3.2.4 Console Bus Error Protection 3-4
  - 3.3 Redundant Components 3-6
    - 3.3.1 Redundant CPU/Memory Boards 3-6
    - 3.3.2 Redundant I/O Boards 3-6
    - 3.3.3 Redundant PCI Cards 3-7
    - 3.3.4 Redundant System Control Boards 3-7
    - 3.3.5 Redundant System Clocks 3-7
    - 3.3.6 Redundant Power 3-7
    - 3.3.7 Redundant Fans 3-8
  - 3.4 Reconfigurable Sun Fireplane Interconnect 3-8
  - 3.5 Automatic System Recovery 3-9
    - 3.5.1 Built-In Self-Test 3-9
    - 3.5.2 Power-On Self-Test 3-9
  - 3.6 System Controller 3-9
    - 3.6.1 Console Bus 3-10

3.6.2	Environmental Monitoring	3-10
3.7	Concurrent Serviceability	3-11
3.7.1	Dynamic Reconfiguration of System Boards	3-11
3.7.2	System Control Board Set Removal and Replacement	3-13
3.7.3	Bulk Power Supply Removal and Replacement	3-13
3.7.4	Fan Tray Removal and Replacement	3-13
3.7.5	Remote Service	3-13
<b>4.</b>	<b>System Interconnect</b>	<b>4-1</b>
4.1	Data-Transfer Interconnect Levels	4-3
4.2	Address Interconnect	4-5
4.3	Data Interconnect	4-7
4.4	Interconnect Bandwidth	4-9
4.5	Interconnect Latency	4-10
<b>5.</b>	<b>System Components</b>	<b>5-1</b>
5.1	Cabinets	5-2
5.1.1	System Power	5-4
5.1.2	System Cooling	5-4
5.2	Centerplanes	5-5
5.2.1	Sun Fireplane Interconnect	5-7
5.3	System Boards	5-7
5.3.1	System Board Set	5-8
5.3.2	Controller Board Set	5-13
	<b>Glossary</b>	<b>Glossary-1</b>



# Figures

---

FIGURE 1-1	Sun Fire E25K/E20K Systems	1–2
FIGURE 1-2	Sun Fireplane Interconnects	1–7
FIGURE 2-1	Example of Domain Configuration With Some Split Board Sets	2–2
FIGURE 3-1	CPU Error Detection and Correction	3–2
FIGURE 3-2	Interconnect ECC and Parity Checking	3–6
FIGURE 4-1	Sun Fire E25K/E20K System Interconnect	4–2
FIGURE 4-2	Sun Fire E25K/E20K System Data—Transfer Interconnect Levels	4–3
FIGURE 4-3	Address Interconnect Levels	4–6
FIGURE 4-4	Data Interconnect Levels	4–8
FIGURE 5-1	Sun Fire E25K/E20K Systems Major Components	5–2
FIGURE 5-2	Sun Fire E25K/E20K Systems Cabinet—Front View	5–3
FIGURE 5-3	Sun Fireplane Interconnect and Other Components	5–6
FIGURE 5-4	Board Set Block Diagram	5–11
FIGURE 5-5	System Board Set Layout	5–13
FIGURE 5-6	System Controller Board Layout	5–14





# Tables

---

<a href="#">TABLE 1-1</a>	Sun Fire E25K/E20K System Maximum Configuration	1–4
<a href="#">TABLE 1-2</a>	Sun Fire E25K/E20K Systems Interconnect Specifications	1–5
<a href="#">TABLE 4-1</a>	Interconnect Levels	4–4
<a href="#">TABLE 4-2</a>	Peak Interconnect Bandwidth	4–9
<a href="#">TABLE 4-3</a>	Pin-to-Pin Latency for Data in Memory	4–10
<a href="#">TABLE 4-4</a>	Pin-to-Pin Latency for Data in Cache	4–11



# Declaration of Conformity

Compliance Model Number: 2080  
Product Name: Sun Fire E25K/E20K System

## EMC

### European Union

This equipment complies with the following requirements of the EMC Directive 89/336/EEC:

EN55022:1995/CISPR22:1997	Class A
EN55024:1998	4 kV (Direct), 8 kV (Air)
EN61000-4-2	3 V/m
EN61000-4-3	1.0 kV Power Lines, 0.5 kV Signal Lines
EN61000-4-4	1 kV Line-Line, 2 kV Line-Gnd Power Lines
EN61000-4-5	3 V
EN61000-4-6	3 A/m
EN61000-4-8	Pass
EN61000-4-11	Pass
EN61000-3-2:1995	Pass
EN61000-3-3:1995	Pass

## Safety

This equipment complies with the following requirements of the Low Voltage Directive 73/23/EEC:

EC Type Examination Certificates:

EN60950:1992, 2nd Edition, Amendments 1,2,3,4,11

TÜV Product Service Certificate No.  
Z1A 01 07 17641 013

IEC 950:1991, 2nd Edition, Amendments 1,2,3,4

Evaluated to all CB Countries

CB Scheme Certificate No. CB 01 07 17641 014

## Supplementary Information

This product was tested and complies with all the requirements for the CE Mark.

---

Dennis P. Symanski  
Manager, Compliance Engineering  
Sun Microsystems, Inc.  
4150 Network Circle  
Santa Clara, CA 95054, USA

DATE

---

Peter Arkless  
Quality Manager  
Sun Microsystems Scotland, Limited  
Springfield, Linlithgow  
West Lothian, EH49 7LR  
Scotland, United Kingdom

DATE

Tel: 650-786-3255  
Fax: 650-786-3723

Tel: 0506-670000  
Fax: 0506 760011



# Preface

---

This document introduces the Sun Fire™ E25K/E20K systems. It describes the cabinet, the system, the configuration, the dynamic system domain configurability, the system boards, and the reliability, availability, and serviceability features.

---

## How This Book Is Organized

Chapter 1 describes the systems and boards, the maximum configurations, and the interconnect architecture.

Chapter 2 describes the configurability, inter-domain networking, domain protection, and domain fault isolation.

Chapter 3 defines system error protection, describes the redundant components and system recovery, discusses the system controller technology, and explains the concurrent serviceability features of the systems.

Chapter 4 describes the heart of the system, which is the Sun™ Fireplane interconnect assembly.

Chapter 5 describes the components within the systems.

Glossary.

---

## Related Documentation

**TABLE P-1** Related Documentation

<b>Application</b>	<b>Title</b>
Site Planning	<i>Sun Fire E25K/E20K Systems Site Planning Guide</i>
Installation	<i>Sun Fire E25K/E20K Systems Read Me First</i>
Installation	<i>Sun Fire E25K/E20K Systems Getting Started</i>
Installation	<i>Sun Fire E25K/E20K Systems Unpacking Guide</i>
Installation	<i>Sun Fire E25K/E20K Systems Hardware Installation and De-Installation Guide</i>
Service	<i>Sun Fire E25K/E20K Systems Service Manual</i>
Service	<i>Sun Fire E25K/E20K Systems Service Reference I–Nomenclature</i>
Service	<i>Sun Fire E25K/E20K Systems Service Reference II–Component Numbering</i>

---

## Accessing Sun Documentation

You can view, print, or purchase a broad selection of Sun documentation, including localized versions, at:

<http://www.sun.com/documentation>

---

## Third-Party Web Sites

Sun is not responsible for the availability of third-party web sites mentioned in this document. Sun does not endorse and is not responsible or liable for any content, advertising, products, or other materials that are available on or through such sites or resources. Sun will not be responsible or liable for any actual or alleged damage or loss caused by or in connection with the use of or reliance on any such content, goods, or services that are available on or through such sites or resources.

---

## Contacting Sun Technical Support

If you have technical questions about this product that are not answered in this document, go to:

<http://www.sun.com/service/contacting>

---

## Sun Welcomes Your Comments

Sun is interested in improving its documentation and welcomes your comments and suggestions. You can submit your comments by going to:

<http://www.sun.com/hwdocs/feedback>

Please include the title and part number of your document with your feedback:

*Sun Fire E25K/E20K Systems Overview*, part number 817-4136-11

---

## United States Export Control Laws Notice

Products covered by and information contained in this service manual are controlled by U.S. Export Control laws and might be subject to the export or import laws in other countries. Nuclear, missile, chemical biological weapons, or nuclear maritime end uses or end users, whether direct or indirect, are strictly prohibited. Export or re-export to countries subject to U.S. embargo or to entities identified on U.S. export exclusion lists, including but not limited to the denied persons and specially designated nationals lists, is strictly prohibited. Use of any spare or replacement CPUs is limited to repair or one-for-one replacement of CPUs in products exported in compliance with U.S. export laws. Use of CPUs as product upgrades unless authorized by the U.S. Government is strictly prohibited.





# Sun Fire E25K/E20K Systems Introduction

---

This chapter provides the following introductory information for the Sun Fire E25K/E20K systems:

- [Section 1.1, “System Boards” on page 1-2](#)
- [Section 1.2, “System Configuration” on page 1-4](#)
- [Section 1.3, “System Interconnects” on page 1-5](#)
- [Section 1.4, “Dynamic System Domains” on page 1-8](#)
- [Section 1.5, “Reliability, Availability, and Serviceability” on page 1-9](#)

The Sun Fire E25K/E20K systems use the latest UltraSPARC® IV Cu CPU and the Sun Fireplane interconnect architecture running the binary-compatible Solaris™ UNIX® operating system ([FIGURE 1-1](#)). The industry-leading dynamic system domain and reliability, availability, and serviceability (RAS) capabilities have been applied and use the active-centerplane technology.

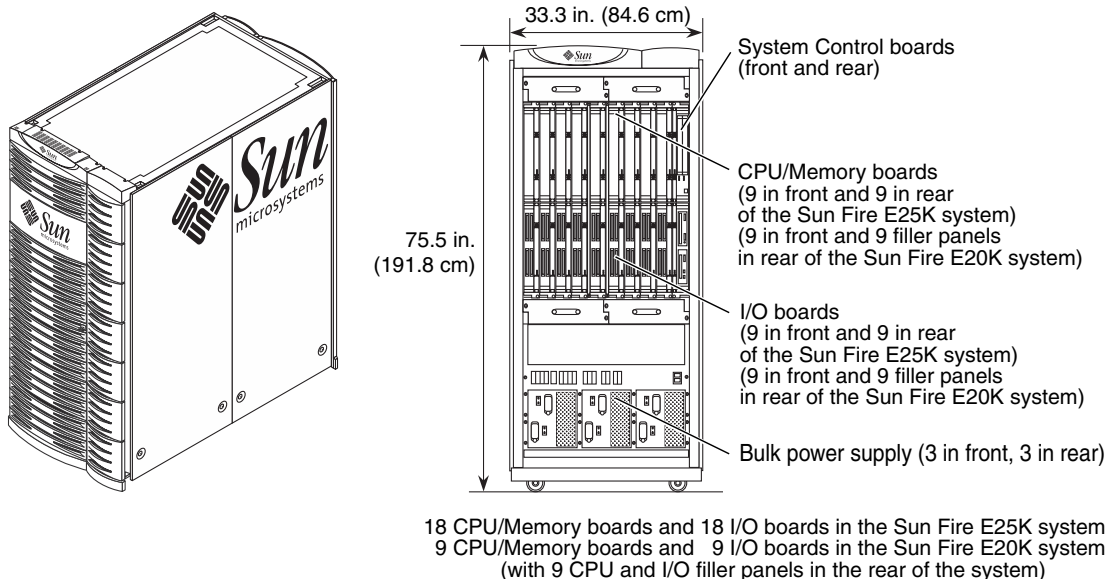

**FIGURE 1-1** Sun Fire E25K/E20K Systems

The Sun Fire E25K system and Sun Fire E20K system are essentially the same. The Sun Fire E25K system has the capacity for 18 CPU/Memory boards and 18 I/O boards. The Sun Fire E20K system has the capacity for nine CPU/Memory boards and nine I/O boards. Each system contains two System Control boards (one main and one spare).

## 1.1 System Boards

### 1.1.1 CPU/Memory Boards

The CPU/Memory board holds four CPUs. Each CPU has an associated memory subsystem of eight DIMMs, so memory bandwidth and capacity are both scaled up as CPUs are added. The memory capacity of the board is 64 Gbytes using 2-Gbyte DIMMs. The maximum memory bandwidth inside a board is 9.6 Gbyte/sec. The CPU/Memory board has a 4.8 Gbyte/sec connection to the rest of the system.

## 1.1.2 I/O Boards

The Sun Fire E25K/E20K hot-swap PCI assembly architecture has two I/O controllers. Each controller provides one 33-MHz peripheral component interconnect (PCI) bus and three 33/66 MHz PCI buses for a total of four on each I/O board. Therefore, each I/O assembly has eight hot-swap component PCI slots. A Sun Fire I/O board has a 2.4 Gbyte/sec connection to the rest of the system.

## 1.1.3 System Controller

The system controller is the heart of the Sun Fire E25K/E20K systems availability and serviceability technology. It configures the system; coordinates the boot process; sets up the dynamic system domains; monitors the system environmental sensors; and handles error detection, diagnosis, and recovery. Two System Control boards are configured into the system to provide redundancy and automatic failover in the event that one board fails.

## 1.1.4 Peripherals

The Sun Fire E25K/E20K cabinet does not have room for peripherals, with the exception of the system controller peripherals (CD-ROM, digital audio tape (DAT) drive, and hard drive). However, more peripheral devices can be configured in additional peripheral expansion racks.

## 1.2 System Configuration

TABLE 1-1 summarizes the maximum configuration of the Sun Fire E25K/E20K systems.

TABLE 1-1 Sun Fire E25K/E20K System Maximum Configuration

Component	E25K Configuration	E20K Configuration
CPU/Memory boards	18	9
CPUs	72	36
Number of DIMMs	576	288
Memory capacity (with 2-Gbyte DIMMs)	1152 GB	576 GB
Sun Fireplane interconnect	Active	Active
Repeater boards	NA	NA
Expander boards	18	9
Domains	18	9
I/O boards (assemblies)	18	9
PCI assembly types	hsPCI+	hsPCI+
PCI slots per assembly	4	4
Maximum PCI slots	72	36
Bulk power supplies	6	6
Power requirements	24 kW	24 kW
System Control boards	2	2
Redundant cooling	Yes	Yes
Redundant AC input	Yes	Yes
Enclosure	Sun Fire E25K/E20K Systems cabinet	Sun Fire E25K/E20K Systems cabinet
Room in enclosure for peripherals	No	No

---

## 1.3 System Interconnects

TABLE 1-2 summarizes the interconnect capacities of the Sun Fire E25K/E20K systems.

TABLE 1-2 Sun Fire E25K/E20K Systems Interconnect Specifications

Interconnect	Specification
System clock	150 MHz
Coherency protocol	Snooping on each board set, directory across a centerplane
System address interconnect	18 snoopy buses, 18x18 global address crossbar, 18x18 global response crossbar,
CPU/Memory board internal bisection bandwidth	4.8 Gbyte/sec
CPU/Memory board off-board data port	4.8 Gbyte/sec
I/O board off-board data port	2.4 Gbyte/sec
System data interconnect	18 3x3 board set crossbars, 18x18 global crossbar
System bisection bandwidth	43 Gbyte/sec
Average lmbench (back-to-back-load) latency assumes random accesses	326 ns

---

**Note** – *Snooping*, is defined as follows in the *PCI System Architecture, Third Edition*, Appendix A: Glossary, 1995, by MindShare, Inc., (ISBN 0-201-40993-3):

Snooping – When a memory access is performed by an agent other than the cache controller, the cache controller must snoop the transaction to determine if the current master is accessing information that is also resident within the cache. If a snoop hit occurs, the cache controller must take an appropriate action to ensure the continued consistency of its cached information.

---

## 1.3.1 Sun Fireplane Interconnect Architecture

The Sun Fire E25K/E20K systems use the Sun Fireplane interconnect system-interconnect architecture that is the coherent shared-memory protocol used by the UltraSPARC IV Cu CPU generation. This is the fourth generation of shared-memory interconnect. Sun Microsystems has implemented an improved system interconnect with each new CPU generation to keep system performance scaling with CPU performance.

The Sun Fireplane interconnect architecture is an evolutionary improvement over the previous-generation Ultra Port Architecture (UPA). The system clock rate is increased by 50% from 100 MHz to 150 MHz. The snoops per clocks are doubled from one half to one. Taken together, this triples the snooping bandwidth to 150 million addresses per second.

The Sun Fireplane interconnect architecture also adds a new layer of point-to-point directory-coherency protocol. This protocol is used in systems that require more bandwidth than a single snoopy bus can provide, enabling coherency to be maintained between multiple snoopy buses.

FIGURE 1-2 shows the Sun Fireplane interconnect architecture of the Sun Fire E25K system. The board diagrams show the actual on-board connectivity, but omit the switch and controller chips for clarity.

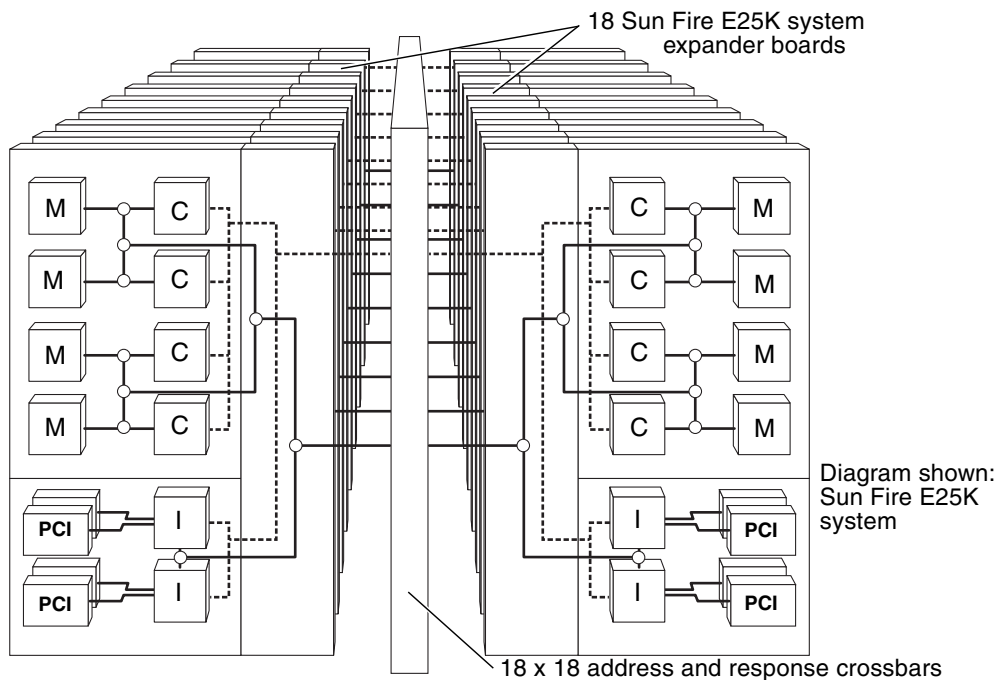

FIGURE 1-2 Sun Fireplane Interconnects

The Sun Fire E25K/E20K systems use an expander board to implement a 3x3 switch between a CPU/Memory board, an I/O board, and the Sun Fireplane interconnect port. The Sun Fire E25K/E20K systems have three 18x18 crossbars on their Sun Fireplane interconnect for addresses, responses, and data so that address traffic does not interfere with data traffic. The peak Sun Fire E25K/E20K systems Sun Fireplane interconnect bandwidth is 43 Gbyte/sec.

## 1.3.2 Address Interconnect

The dashed lines in [FIGURE 1-2](#) are the snoopy address buses. A snoop can occur at every system clock. In the Sun Fire E25K/E20K systems, there is a separate snoopy address bus on each board set. A board set is the combination of a CPU/Memory board, an I/O board, and an expander board. Coherency is maintained between board sets by using the point-to-point (directory) portion of the coherency protocol.

## 1.3.3 Data Interconnect

The solid lines in [FIGURE 1-2](#) represent the data paths. The small circles at the intersections of these lines indicate three-port switches. The CPU/Memory board has three levels of 3x3 switches between a CPU or memory unit and the off-board port. The off-board bandwidth of a CPU/Memory board is 4.8 Gbyte/sec. The bandwidth of an I/O board is 2.4 Gbyte/sec.

---

## 1.4 Dynamic System Domains

Each domain in the Sun Fire E25K/E20K systems includes one or more CPU/Memory boards and one or more I/O boards. Each domain runs its own instance of the Solaris Operating System and has its own peripherals and network connections. Domains can be reconfigured without interrupting the operation of other domains. Domains can be used for:

- Testing new applications
- Updating the operating system
- Supporting various departments
- Removing and reinstalling boards for repair or upgrade

Here is one example of partitioning a fully populated Sun Fire E25K system into three domains to handle three types of functions:

- Domain 1 is set up to run online transaction processing (OLTP). It is a 32-CPU domain containing eight boards of four CPUs each.
- Domain 2 is set up to run decision support software (DSS). It is also a 32-CPU domain containing eight boards of four CPUs each.
- Domain 3 is set up as a domain for developers. It is a two-board domain, each board with four CPUs.

Boards can be automatically migrated between domains as the load change demands.

The Sun Fire E25K system can have up to 18 domains. The Sun Fire E20K system can have up to 9 domains. Domains are isolated from each other by the interconnect application-specific integrated circuits (ASICs).



---

## 1.5 Reliability, Availability, and Serviceability

Reliability, availability, and serviceability (RAS) are critical requirements of customers who deploy business-critical applications. The Sun Fire E25K/E20K systems build upon the industry-leading RAS capabilities. The sections that follow describe some of the major features that improve RAS.

### 1.5.1 Integrated Circuit Reliability

- **Start-up diagnostics.** All major Sun Fire E25K/E20K systems ASICs do a built-in self-test (BIST) upon powering-on. This applies random patterns at a system clock rate to provide a high-fault coverage of combinatorial logic. The power-on self-test (POST) is controlled from the system controller, and first tests each logic block in isolation. Then the POST continues testing using more and more of the system. Failing components are electrically isolated from the Sun Fireplane interconnect. The result is that the system is booted only with logic blocks that have passed this self-test and that should operate without error.
- **Internal SRAM protection inside the UltraSPARC IV Cu CPU.** With higher-density CPUs and lower core voltages, SRAM cells have become more vulnerable to bit flips from cosmic ray disturbances. Single-bit errors for the majority of the internal SRAMs are detected and are recoverable.
- **External SRAM protection.** All external SRAMs are protected by error-correcting codes (ECC). This includes the external cache data of the CPU and the coherency directory cache of the Sun Fire E25K/E20K systems.

### 1.5.2 Interconnect Reliability

- **Address interconnect protection.** The Sun Fire E25K/E20K address buses and control signals are parity protected to detect single-bit errors. In addition, the address and response crossbars on the Sun Fireplane interconnect have ECC protection to correct single-bit errors and detect double-bit errors.
- **Data interconnect protection.** The entire system data path is protected by ECC, which corrects single-bit errors and detects double-bit errors before they can cause data corruption. ECC is generated by a CPU or I/O controller when it initiates a write command. The extra bits are carried throughout the interconnect to the destination. The memory subsystem does not check or correct errors, but only provides the extra storage bits. When data is read out of memory, it is checked and, if necessary, corrected by the receiving CPU or I/O controller.

To help isolate failures, parity is also checked as data is passed from chip to chip. The data switch ASICs also check ECC. The ECC patterns use detect-complete DRAM chip failures but cannot correct them.

## 1.5.3 Fault-Tolerant Redundancy

A failure in these subsystems does not cause any loss of availability.

- **N+1 redundancy.** The AC power inputs, bulk power supplies, and cooling fans are all fault tolerant through N+1 redundancy. If one of these subunits fails, the remainder of the components can continue system operation without interruption.
- **Failover while running.** The System Control boards are configured in pairs. One is active, and the other is a hot-spare. In the event of a failure of the system controller CPU or of the clock generation logic, control is switched from the failed board to the other board without system interruption.

## 1.5.4 Reconfiguration After Failure

- **Automatic system recovery.** A suitably configured system always reboots after a failure. The system controller locates the fault; reconfigures the system excluding the failed CPU, memory, or interconnect component; and reboots the operating system.
- **Interconnect reconfiguration after failure.** After a system interconnect failure occurs, the system restarts with the bad interconnect components isolated and with half the system bandwidth still available. The three crossbars can be separately reconfigured between full and degraded mode on a domain-by-domain basis.

## 1.5.5 Serviceability

- **System controller.** The System Control board is the heart of the RAS technology. The SC CPU board is an off-the-shelf SPARCengine® Netra 2140 6U cPCI board with an UltraSPARC-IIi embedded system. This board runs Solaris software and System Management software. The system controller has access by means of the joint test action group (JTAG) to registers in each significant chip in the machine, and continuously monitors the state of the machine. If a problem is detected, the system controller attempts to determine what hardware has malfunctioned and then takes steps to prevent that hardware from being accessed until it has been replaced.

- **Console bus.** The console bus is a secondary bus that enables the system controller to access the inner workings of the machine without having to rely on the integrity of the system address and data buses. This enables the system controller to operate even when there is a fault that prevents the system operation from continuing. It is protected by parity.
- **Environmental monitoring.** The system controller monitors the cabinet environment for key measures of system stability such as temperature, fan operation, and power supply performance.
- **Concurrent serviceability.** The fans, bulk power supplies, and system boards are all hot-swap components. They can be removed and replaced in a running system.
- **Dynamic system domains.** Dynamic system domains enable a repaired or upgraded board to be added or removed from a running domain.



# Dynamic System Domains

---

The Sun Fire E25K/E20K systems contain dynamic domains. These domains are described in the following sections.

- [Section 2.1, “Domain Configurability” on page 2-1](#)
- [Section 2.2, “Domain Protection” on page 2-3](#)
- [Section 2.3, “Domain Fault Isolation” on page 2-3](#)

The Sun Fire E25K system can be dynamically subdivided into as many as 18 dynamic system domains. The Sun Fire E20K system can be subdivided into as many as 9 dynamic system domains. Each domain has a separate boot disk (to execute a specific instance of the Solaris OS) as well as separate disk storage, network interfaces, and I/O interfaces. CPU boards and I/O boards can be separately added and removed from running domains.

Domains are used for server consolidation to run separate parts of a solution, such as an application server, a web server, and a database server. The domains are hardware protected from hardware or software faults in other domains.

---

## 2.1 Domain Configurability

Each of the system boards (slot 0 and slot 1 boards) can be independently added to, or removed from, a running domain. This enables CPU and memory resources to be moved from one domain to another without disturbing the disk storage and network connections. In the Sun Fire E25K system, each domain must have an I/O board; therefore, there is a maximum of 18 domains. In the Sun Fire E20K system, each domain must have an I/O board; therefore, there is a maximum of 9 domains.

When the two system boards in a board set are in separate domains, this board set is termed a *split expander*. The expander board keeps the transactions separate for each system board. [FIGURE 2-1](#) shows an example of configuration with some of the board sets split between the two domains. No physical proximity is needed for boards in a domain.

Since split-expander hardware is shared between two domains, this board set failure will bring down both domains. For example, if a fully configured system is divided into two nine-board set domains, the impact of all split, versus all unsplit, expanders is on the order of 5% higher mean time between failure (MTBF). Also, memory accesses that go through a split expander take two system clocks (13 ns) longer. If all expanders were split, the load-use latency for accesses to other board sets would increase about 6%.

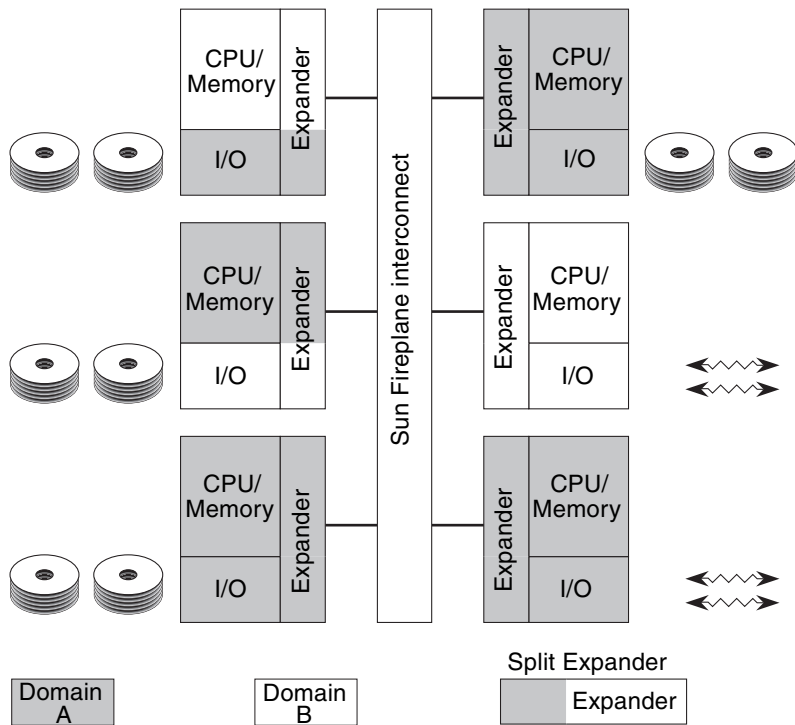

Diagram shown for the Sun Fire E25K system

**FIGURE 2-1** Example of Domain Configuration With Some Split Board Sets

---

## 2.2 Domain Protection

Primary domain protection is accomplished in the address extender queue (AXQ) ASICs by checking each transaction for domain validity when a transaction is first detected. In the Sun Fire E25K system, the system data interface (SDI) chips can also screen data transfer requests for valid destinations to as many as 36 system boards. In addition, each Sun Fireplane interconnect arbiter (data, address, response) screens requests to as many as 18 expanders. In the Sun Fire E20K system, the SDI chips can screen data transfer requests for valid destinations to as many as 18 system boards. Each Sun Fireplane interconnect arbiter (data, address, response) screens requests to as many as 9 expanders. This is a double check on the other domain protection mechanisms, which are in the AXQ and the SDI chips.

If a transgression error is detected in the AXQ, the AXQ treats the error operation like a request to nonexistent memory. It reissues the request without asserting a mapped coherency protocol signal, causing a Solaris software switch execution from one process to another. A transgression error in the Sun Fireplane interconnect causes a *domainstop* of the transgressing domains, because this error must indicate a failure of the primary protection mechanism.

---

## 2.3 Domain Fault Isolation

Domains are protected against software or hardware faults in other domains. If there is a fault in the processor or memory hardware that is assigned to a particular domain, only that one domain will be affected. If there is a fault in hardware that is shared between multiple domains, only those domains that share the hardware are affected.

As an example of hardware shared between two domains, consider a system which is configured to have a CPU/Memory board in one domain and its associated I/O board in another domain. The logic on a split expander board is shared between those two domains. A fault in a split expander or its control wiring to the Sun Fireplane interconnect causes a failure only in those two domains. A fault in globally shared hardware, such as the system clock generator or Sun Fireplane interconnect chips, causes a failure in all domains.

Fatal errors, such as a parity error in control wiring or a faulty ASIC, cause a *domainstop*. The steering signals from the expander boards to the arbiter chips of the Sun Fireplane interconnect are parity protected. If there is a parity error, the multiple copies of the Sun Fireplane interconnect arbiter could get out of sync. Therefore, this type of parity error causes an immediate domainstop of the domain.

Nonfatal errors or correctable single-bit errors in packets sent through the Sun Fireplane interconnect causes a *recordstop*. A recordstop freezes the history buffers in the ASICs, enabling failure information to be scanned out through JTAG while the domain continues to run.

For a split-expander transaction (expander with board 0 and board 1 in different domains), it is necessary to keep the arbiters in sync so that the error cannot propagate to multiple domains. In this type of transaction, two extra cycles of latency are introduced so that a steering parity error can be detected by all arbiters before one arbiter processes its own correct version of the steering. Configure your system with a minimum of split expanders to improve system performance.

The steering signals within the Sun Fireplane interconnect, from the data arbiter ASICs to the data MUX ASICs, are parity protected. It is not possible for the data multiplexer (MUX) chips to cross-check for errors before processing on the steering. Therefore, a parity error on these localized wires could cause a domainstop in any or all domains.



# Reliability, Availability, and Serviceability

---

Reliability, availability, and serviceability (RAS) assess and measure system ability to operate continuously and to minimize service times. The reliability of a system reduces failures and ensures data integrity. Serviceability provides short service cycles when component upgrades are necessary or failures occur. When high reliability to avoid failures and quick serviceability, to recover rapidly from failures are combined, the result is high availability. The availability of a system defines continuous accessibility to the functions and applications supported by the system. The supported functions and applications are described in the following section:

- [Section 3.1, “SPARC CPU Error Protection” on page 3-1](#)
- [Section 3.2, “System Interconnect Error Protection” on page 3-3](#)
- [Section 3.3, “Redundant Components” on page 3-6](#)
- [Section 3.4, “Reconfigurable Sun Fireplane Interconnect” on page 3-8](#)
- [Section 3.5, “Automatic System Recovery” on page 3-9](#)
- [Section 3.6, “System Controller” on page 3-9](#)
- [Section 3.7, “Concurrent Serviceability” on page 3-11](#)

---

## 3.1 SPARC CPU Error Protection

The CPU has error correction code (ECC) protection on its external cache SRAM and parity protection on the major internal SRAM structures, as shown in [FIGURE 3-1](#). The letters *P* and *E* in the block diagram denote parity generate and check; and ECC generate, check, and correct by the receiving unit, respectively. A parity error on an internal cache structure is corrected by software, ensuring correct operation after the fault.

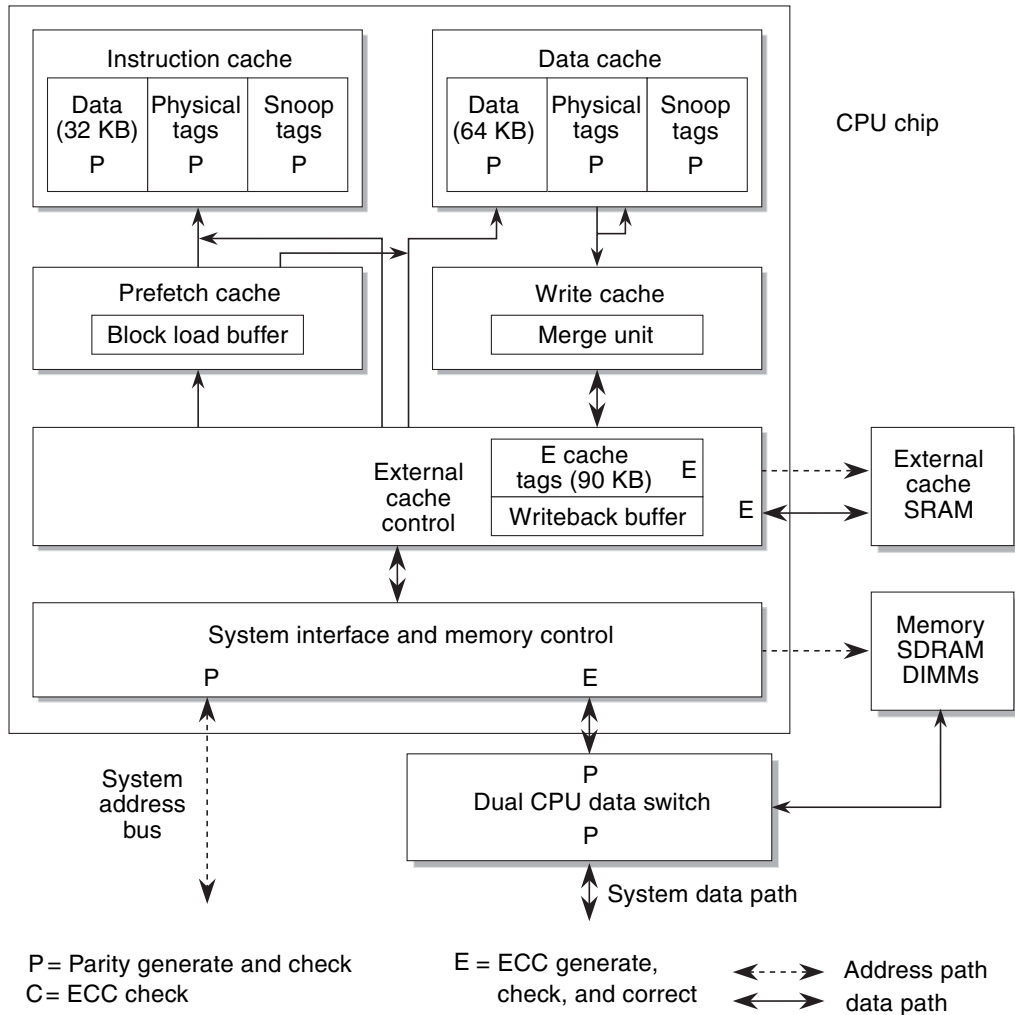

FIGURE 3-1 CPU Error Detection and Correction

The external cache data resides on eight high-speed (4 ns) SRAMs. A single-bit error-correcting and double-bit error detecting code protects the 64-byte-wide cache lines. Errors during data-cache or instruction-cache fills are recovered by software flushing and invalidation. Errors during system data transactions are corrected by hardware.

The Sun Fire E25K/E20K address bus connections between the CPU and the address repeater are protected by parity.

The CPU generates both parity and ECC for all outgoing data blocks. The parity is checked by the receiving dual-CPU data switch. The ECC is checked by all data switch units in the path of a transfer. ECC is checked and corrected by the CPU when it receives a data block.

---

## 3.2 System Interconnect Error Protection

FIGURE 3-2 shows the protection methods at various points in the address and data interconnect. The letters *P*, *E*, and *C* in the block diagram denote parity generate and check; ECC check; and ECC generate, check, and correct by the receiving unit, respectively. Dashed lines denote the address interconnect, and solid lines denote the data interconnect.

### 3.2.1 Address Interconnect Error Protection

The Sun Fireplane interconnect address bus has three parity-error bits. In addition to the bus-level protection, the address and response crossbars on the Sun Fire E25K/E20K Sun Fireplane interconnect have ECC protection for address transactions across the Sun Fireplane interconnect. The ECC corrects single-bit address errors and detects double-bit errors. An address parity or uncorrectable ECC error stops execution in the affected dynamic system domain.

### 3.2.2 Data Interconnect Error Protection

All data interconnect transactions move a 64-byte-wide data block. System devices generate ECC when they source data, either for a write from the device or in response to a read of the device. They check ECC and correct single-bit errors when they receive data. Data is thus protected against both memory and data path errors from end to end.

## 3.2.3 Data Interconnect Error Isolation

If system devices checked only ECC when they received data, it would be difficult to diagnose the cause of an error. If a device generates bad ECC on a write to memory, the error can be detected by some other devices, but the cause of the error is difficult to isolate. There are two additional checks to help isolate the cause of the errors:

- Individual point-to-point data links are covered by parity. This is denoted by a *P* in [FIGURE 3-2](#).
- ECC is checked as it enters or leaves each system device by the level 1 data switch. This is denoted by an *E* in [FIGURE 3-2](#).

The ECC checks that are performed by the data switch can identify the source of ECC errors in most cases. A particularly hard case for ECC error correction occurs when a device writes bad ECC into memory. These errors are detected much later by other devices reading these locations. Since the bad device writer might have written bad ECC to many locations and these might be read by many devices, the errors appear to be in many memory locations while the real error might be a single bad device writer.

Because the data switch ASICs check the ECC for all data entering or leaving each device from other devices, the original source of errors can be isolated. For example, a bad device writer that writes bad ECC to a memory on a different board produces ECC errors that are detected in two data switches. The direction and transaction tag information can identify which CPU pair was the source of the error and which device is the target of a bad ECC device writer.

If the bad device writer writes bad ECC to its local memory, the data does not pass through a data switch. Therefore, the bad device writer is not detected until the data with the bad ECC is read by either the same CPU or another device. In either case, the cause of the ECC error can be isolated to the pair of CPUs that share the dual CPU data switch (DCDS). If the data is read by the same CPU, the fact that the data switch on that board never detected an error indicates that the data was corrupted by the local CPU or the DCDS. If the data is read by a different CPU pair, then the data passes through a data switch and the ECC error is detected as originating from a particular DCDS or the associated CPUs.

## 3.2.4 Console Bus Error Protection

The console bus is a secondary bus that enables access by the system controller to the inner workings of the machine without having to rely on the integrity of the primary data and address buses. This enables the system controller to operate even when there is a fault preventing the continuation of the main operation. This console bus action is common to all domains and is parity protected.

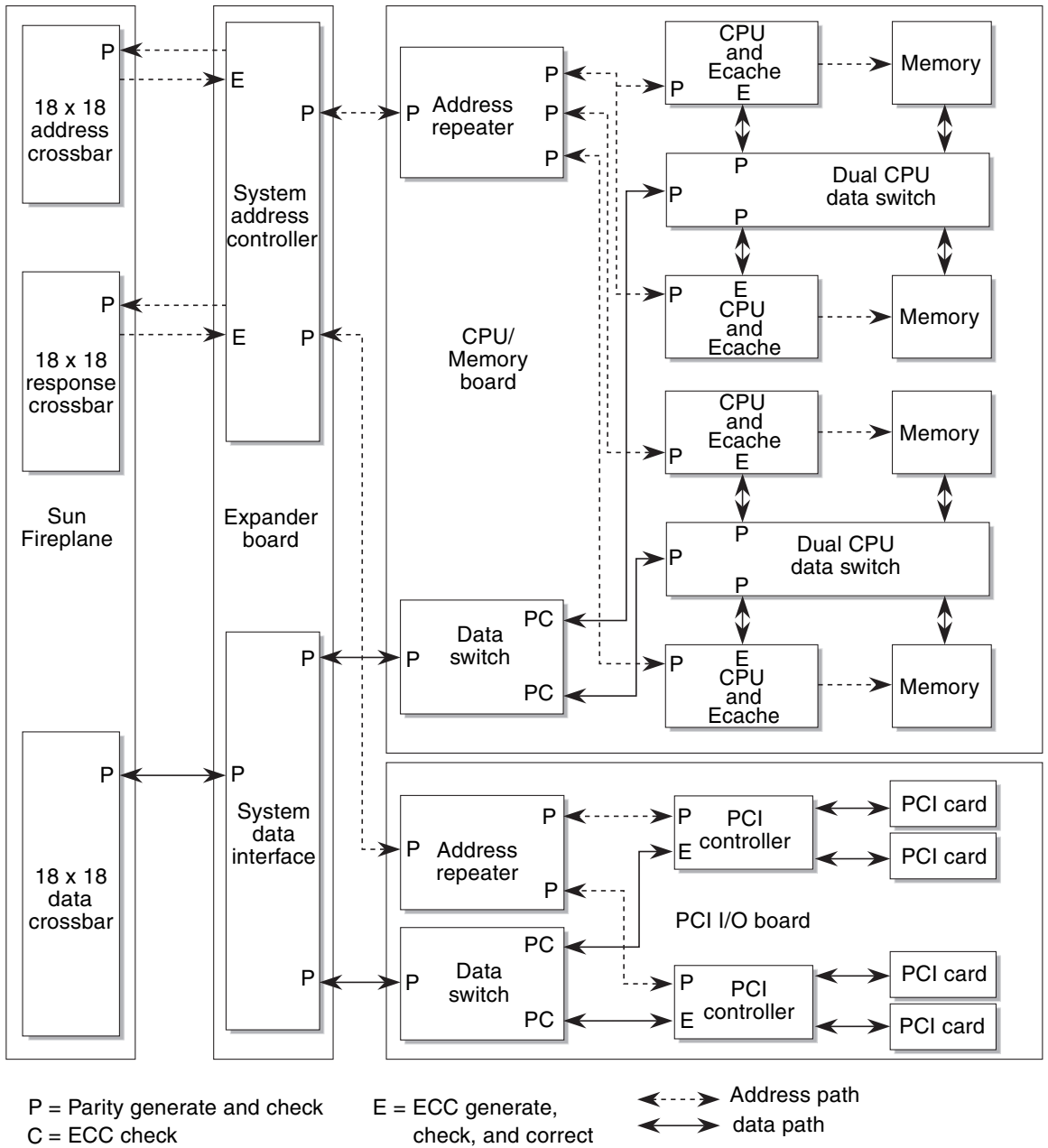

FIGURE 3-2 Interconnect ECC and Parity Checking

---

## 3.3 Redundant Components

System availability is greatly enhanced by the ability to configure redundant components. All hot-swap components in the system can be configured redundantly, if the customer desires. Each system board is capable of independent operation. Sun Fire E25K/E20K systems are built with multiple system boards and are inherently capable of operating with a subset of the configured boards.

Redundant system components include:

- CPU/Memory boards
- I/O boards
- PCI cards
- System Control boards
- System clock sources
- Bulk power supplies
- Fan trays

### 3.3.1 Redundant CPU/Memory Boards

A Sun Fire E25K system can configure up to 18 CPU/Memory boards. A Sun Fire E20K system can configure up to 9 CPU/Memory boards. Each board contains up to four CPUs and their associated memory banks. Each CPU/Memory board is capable of independent operation and can be hot-swapped out of a running system and moved between system domains. The system is inherently capable of operating with a subset of the configured boards.

### 3.3.2 Redundant I/O Boards

A Sun Fire E25K system can configure up to 18 I/O boards. A Sun Fire E20K system can configure up to 9 I/O boards. Each board supports up to four PCI cards. The I/O boards can be hot-swapped out of running systems and moved between system domains.

### 3.3.3 Redundant PCI Cards

You can mount a standard PCI card on the Sun Fire E25K/E20K PCI I/O board by using a special cassette that enables the cards to be changed using the hot-swap-replacement procedures. You can configure systems with multiple connections to the peripheral devices, enabling redundant controllers and channels. Software maintains the multiple paths and can switch to an alternate path if the primary fails.

### 3.3.4 Redundant System Control Boards

Sun Fire E25K/E20K systems contain two System Control boards. The system controller software running in each embedded CPU checks the other system controller and copies state information to enable automatic failover to the other system controller if the active System Control board fails.

The systems also contain a main System Control board and an alternate hot-swap replaceable System Control board. The main System Control board provides all the system controller resources for the system. If failures of the hardware or software occur on the main System Control board, or if failures on any hardware control path (console bus interface, Ethernet interface) from the main System Control board to other system devices occur, the system controller failover software automatically triggers a failover to the spare System Control board. The spare System Control board assumes the role of the main System Control board and takes over all the main system controller responsibilities. The system controller data, configuration, and log files are replicated on both System Control boards.

### 3.3.5 Redundant System Clocks

Sun Fire E25K/E20K systems have redundant system clocks. If the system clock on one System Control board fails, the consumers of the clock lines continue to draw clock resources from the other System Control board until downtime can be arranged to replace the failed System Control board.

### 3.3.6 Redundant Power

The Sun Fire E25K/E20K cabinet uses six 4-kW dual AC–DC power supplies. Two power cables go to each AC power supply, so that each can connect to a separate power source. These supplies convert the input power to 48 VDC, and are *N*+1 redundant. Therefore, the system can continue running with a failed power supply, if necessary. The power supplies can be replaced while the system is in operation.

Power is distributed to the individual system board sets through separate DC circuit breakers. Each board set has its own on-board voltage converters that transform 48 VDC to the levels required by the on-board logic components. Failure of a DC-to-DC converter affects only that particular system board.

### 3.3.7 Redundant Fans

There are four fan trays above and four fan trays below the system boards. Each fan tray contains two layers of six-inch fans. The fans have two speeds: nominal and high speed. If any of the sensed components in the system overheat, all fans are set to high speed. If a single fan fails, the redundant fan in the corresponding layer of the tray switches to high speed. The fans are  $N+1$  redundant, enabling the system to run with a failed fan. The fan trays can be hot-swapped while the system is running.

---

## 3.4 Reconfigurable Sun Fireplane Interconnect

Sun Fire E25K/E20K systems have three independent crossbars implemented on the Sun Fireplane interconnect: one for addresses, one for responses, and one for data. The Sun Fireplane interconnect contains 20 ASICs and is the only non hot-swap logic component in the system. Because a failed Sun Fireplane interconnect ASIC cannot be removed from a running system, each of the three Sun Fireplane interconnect crossbars can be independently configured in and out of a degraded mode. A degraded mode is separately configurable for each system domain.



---

## 3.5 Automatic System Recovery

A suitably configured system always reboots after a failure. The system controller locates the fault; reconfigures the system excluding the failed CPU, memory, IO, or interconnect component; and reboots the operating system.

The system controller configures only the parts that have a clear fatal-error bit. Field-replaceable units (FRUs) that have already been detected as faulty, by this or another machine, should not be used.

### 3.5.1 Built-In Self-Test

Built-in self-test (BIST) logic in the ASICs applies pseudo-random patterns at the system clock rate, providing high-fault coverage of combinatorial logic. The local BIST operates within each ASIC and verifies the correct operation of the ASIC. The interconnect built-in self-test performs an interconnect test to verify that the ASICs can communicate across the interconnect. The local built-in self-tests rely on the interfaces of each ASIC sending each other known test data.

### 3.5.2 Power-On Self-Test

The power-on self-test (POST) tests each logic block first in isolation, and then with progressively more of the system. Failing components are isolated from the Sun Fireplane interconnect. The result is that the system is booted only with logic blocks that have passed this self-test and that should operate without error.

Local POST runs in each CPU and system POST runs in the system controller.

---

## 3.6 System Controller

The heart of Sun's availability technology is the system controller. This controller contains an off-the-shelf SPARCengine Netra 2140 6U cPCI board with an UltraSPARC-IIi embedded system. This board runs Solaris software and System Management software.

The system controller has access through JTAG to registers in each significant chip in the machine and continuously monitors the state of the machine. If a problem is detected, the system controller attempts to determine what hardware has failed and then takes steps to prevent the failed hardware from being used until it has been replaced.

The system controller performs the following main functions:

- Configures the system by setting up the system and coordinating the boot process
- Sets up the system partitions and domains
- Generates the system clocks
- Monitors the environmental sensors throughout the system
- Detects and diagnoses errors and enables recovery
- Provides the platform console functionality and the domain consoles
- Provides routing through a system log of messages to a syslog host

## 3.6.1 Console Bus

The console bus is a secondary bus that enables the system controller to access the inner working of the system without having to rely on the integrity of the system address and data buses. This enables the system controller to operate even when there is a fault preventing the continuation of system operation. The system controller is parity protected.

## 3.6.2 Environmental Monitoring

The system controller regularly monitors the system environmental sensors in order to have enough advance warning of a potential condition so that the machine can be brought gracefully to a halt—avoiding physical damage to the system and possible corruption of data.

The environmental items monitored include:

- Power state
- Voltages
- Fan speed
- Temperatures
- Device failure
- Device presence

---

## 3.7 Concurrent Serviceability

The most significant serviceability feature of the Sun Fire E25K/E20K systems is the replacement of system boards online as a *concurrent service*, the ability to service various parts of the machine without interfering with a running system. Failing components are identified in the failure logs with the FRUs clearly identified. With the exception of the Sun Fireplane interconnect, power centerplane, fan backplane, and the power module, all boards and power supplies in the system can be removed and replaced during system operation without scheduled downtime using hot-swap replacement procedures. You can also replace the System Control board that is currently active or switch control to the redundant System Control board without causing a disruption in the main system operation.

The ability to repair these items without downtime is a significant contributor in achieving higher availability. A by-product of this online repairability of the system concerns upgrades to the on-site hardware. Customers might want to have additional memory or an extra I/O controller. These operations can be accomplished online, resulting in only a brief (and minor) loss of performance while the system board affected is temporarily taken out of service.

Concurrent service is a function of the following hardware facilities:

- All Sun Fireplane interconnect connections are point to point, which makes it possible to logically isolate system boards by dynamically reconfiguring the system.
- Sun Fire E25K/E20K systems use a distributed DC power system. Each system board has its own power supply, enabling each system board to be powered on or off individually.
- All ASICs that connect an off-board Sun Fireplane interconnect have a loopback mode that enables the system board to be verified before it is dynamically reconfigured into the system.

### 3.7.1 Dynamic Reconfiguration of System Boards

The online removal and replacement of a system board from a running system is called *dynamic reconfiguration*. For example, the board can be configured in the system even though one of its CPUs failed. To replace the module without incurring downtime, dynamic reconfiguration can isolate the board from the system, enabling the board to be replaced using the hot-replacement procedures. This dynamic reconfiguration operation has three distinct steps:

- Dynamic detach
- Hot-swap

## ■ Dynamic attach

Dynamic reconfiguration enables a board that is not currently being used by the system to provide resources to the system. It can be used in conjunction with hot-swap replacement to upgrade a system without incurring any downtime or to move resources from one domain to another domain. It can also be used to replace a defective module that was deconfigured by the system and subsequently hot-swapped and repaired or replaced.

Dynamic deconfiguration and reconfiguration are accomplished by the system administrator (or service provider) working through the system controller. The following process is used during configuration changes and hot-swap replacement procedures:

1. The Solaris operating system scheduler is informed of the board in question, to prevent new processes from starting. Meanwhile, any running processes and I/O operations are completed, and memory contents are rewritten into other memory banks.
2. A switchover to alternate I/O paths takes place so that when the I/O assembly is removed, the system continues to have access to the data.
3. The system administrator performs the hot-swap operation, by manually removing the now deconfigured system board from the system. The removal sequences are controlled by the system controller, and the system administrator follows the software instructions.
4. The removed system board is repaired, exchanged, or upgraded.
5. The new board is reinserted into the system.
6. The swapped system board is dynamically configured by the operating system when inserted. The I/O can be switched back, the scheduler assigns new processes, and the memory starts to fill.

With a combination of dynamic reconfiguration and hot-swap replacement, the Sun Fire E25K/E20K systems can be repaired or upgraded with minimal user inconvenience. The hot-swap replacement of hardware minimizes this interval to minutes by the on-site exchange of system boards.

An additional advantage of dynamic reconfiguration and hot-swap replacement of hardware is that online system upgrades can be performed. For instance, when a customer purchases an additional system board, it too can be added to the system without disturbing operation.

## 3.7.2 System Control Board Set Removal and Replacement

The hot-spare System Control board set, which is not actively supplying system clocks, can be removed from a running system.

## 3.7.3 Bulk Power Supply Removal and Replacement

Bulk 4-kW dual AC-DC power supplies can be hot-swapped with no interruption to the system because the remaining power supplies can power the system during replacement.

## 3.7.4 Fan Tray Removal and Replacement

When a fan fails, the corresponding fan on the other layer in the fan tray switches to high-speed operation by the system controller to compensate for the reduced airflow. The system is designed to operate normally under these conditions until the failed fan assembly can be conveniently serviced. The fan trays can be hot-swapped with no interruption to the system.

## 3.7.5 Remote Service

An optional capability is available for automatically reporting by email unplanned reboots and error log information to customer service headquarters sites. Every system controller has remote access capability that enables remote login to the system controller. Through this remote connection, all system controller diagnostics are accessible. Diagnostics can be run remotely or locally on deconfigured system boards while the Solaris software is running on the other system boards.



## System Interconnect

---

The sections in this chapter contain a full description of the Sun Fireplane interconnect.

- Section 4.1, “Data-Transfer Interconnect Levels” on page 4-3
- Section 4.2, “Address Interconnect” on page 4-5
- Section 4.3, “Data Interconnect” on page 4-6
- Section 4.4, “Interconnect Bandwidth” on page 4-8
- Section 4.5, “Interconnect Latency” on page 4-9

FIGURE 4-1 shows an overview of the Sun Fire E25K/E20K interconnect. The small numbers in the block diagram are peak data bandwidths at each level of the interconnect.

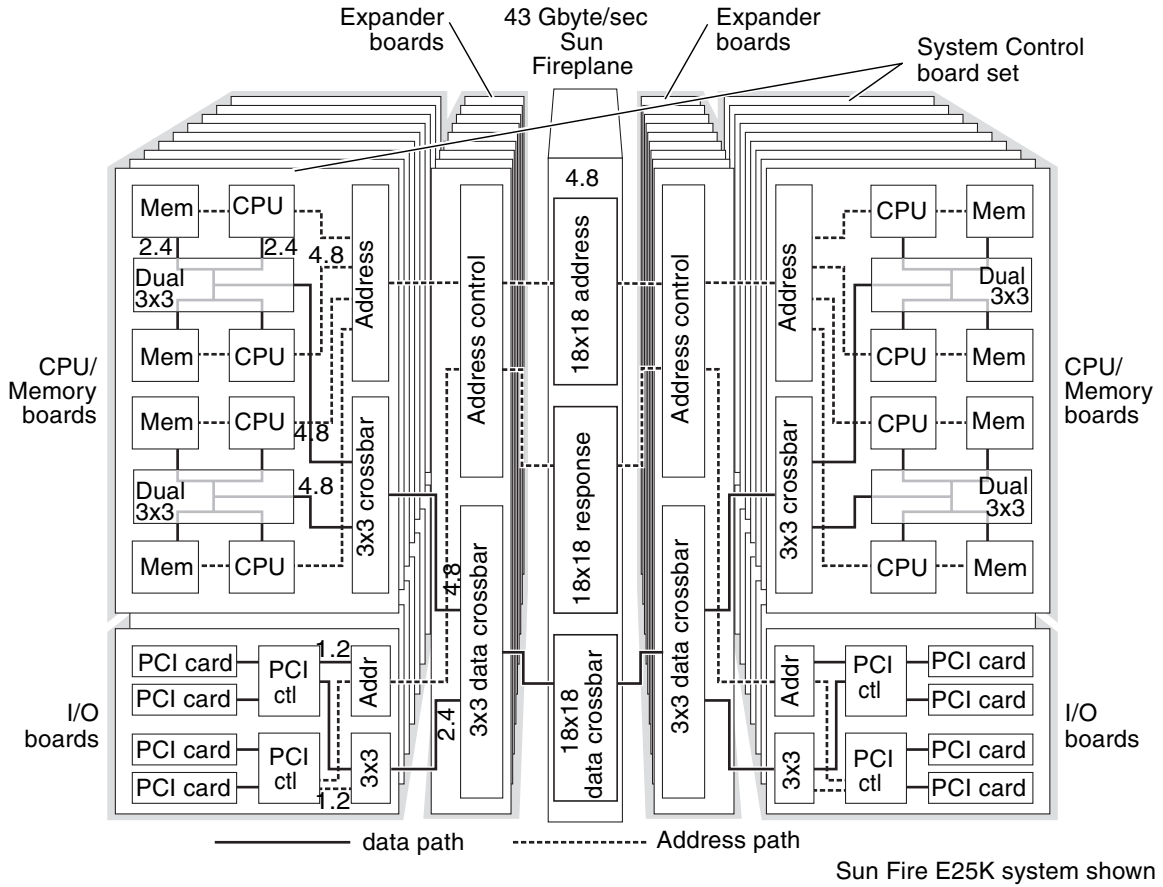

**FIGURE 4-1** Sun Fire E25K/E20K System Interconnect



---

## 4.1 Data-Transfer Interconnect Levels

The Sun Fire E25K/E20K interconnect is implemented in several physical layers (FIGURE 4-2). The realities of physical packaging make it impractical to connect all the functional units (CPU/Memory units, I/O controllers) of a large server directly together. The system interconnect of a server is implemented as a hierarchy of levels: chips connect to boards, which connect to the Sun Fireplane interconnect. The latency is lower and the bandwidth is higher between components on the same board, because there are more connections between them than there are to off-board components.

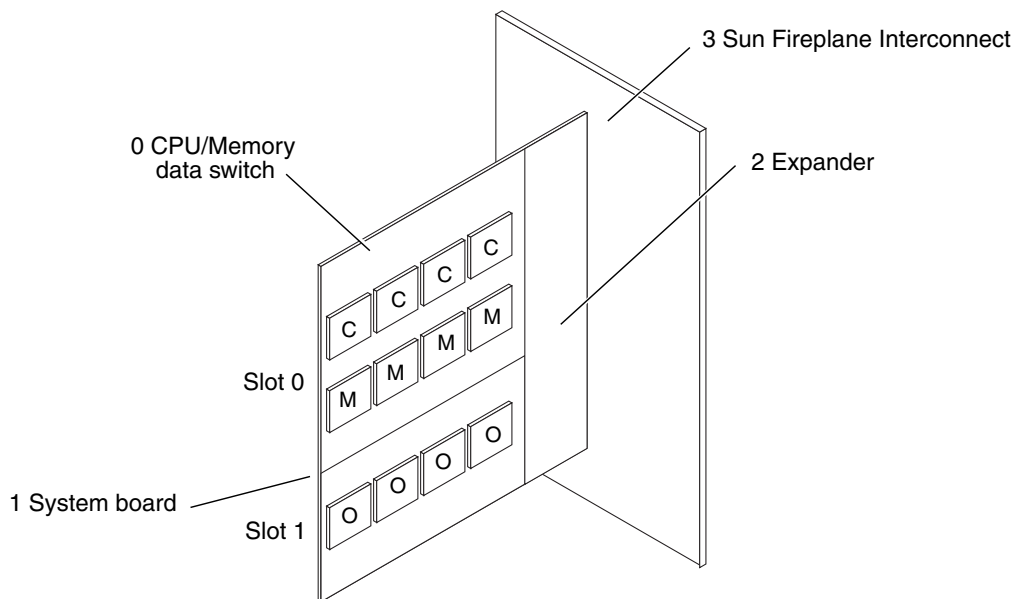

**FIGURE 4-2** Sun Fire E25K/E20K System Data—Transfer Interconnect Levels

The system has two separate interconnects, one for address interconnect and another for data transfer interconnects (TABLE 4-1).

- The address interconnect has a three-level hierarchy:
  - A The address repeater on each CPU/Memory board or I/O assembly collects address requests from the devices on that board and forwards them to the system address controller on the expander board.
  - B Each board set expander has a snoopy address bus, with a coherency bandwidth of 150 million snoops per second.
  - C The 18x18 Sun Fireplane interconnect address and response crossbars have a peak bandwidth of 1.3 billion requests and 1.3 billion responses per second.
- The data-transfer interconnect has a four-level hierarchy of crossbars, as indicated in FIGURE 4-2:
  - 0 Two CPU/Memory pairs are connected by three 3x3 switches to the board-level crossbar.
  - 1 Each CPU/Memory board has a 3x3 crossbar between its system port and two pairs of CPUs. Each PCI board has a 3x3 crossbar between its system port and two PCI bus controllers.
  - 2 Each expander board provides a 3x3 crossbar between its Sun Fireplane interconnect port and two system boards.
  - 3 The 18x18 Sun Fireplane interconnect data crossbar has a total bandwidth of 43 Gbyte/sec, with a 4.8 Gbyte/sec port to each of the 18 board sets.

Sun Fire E25K/E20K systems have an additional level of interconnect that connects two boards to the Sun Fireplane interconnect port. This interconnect is the expander.

**TABLE 4-1** Interconnect Levels

Interconnect	Level	Description
<b>Address interconnect</b>	<b>A board set:</b>	Snoopy bus segment
	<b>B expander:</b>	Snoopy bus segment
	<b>C Sun Fireplane interconnect:</b>	Two 18-port switches for point-to-point transactions
<b>Data-transfer interconnect</b>	<b>0 CPU/Memory:</b>	Two 3-port switches
	<b>1 board set:</b>	3-port switch
	<b>2 expander:</b>	3-port switch
	<b>3 Sun Fireplane interconnect:</b>	18-port switch

In the Sun Fire E25K/E20K systems, latency is lowest to memory on the same board because fewer levels of logic need to be crossed.

## 4.2 Address Interconnect

The Sun Fire E25K/E20K address interconnect has three levels of chips (FIGURE 4-3).

- **Board set level.** The address repeater collects and broadcasts address transactions to and from the on-board CPUs and I/O controllers.
- **Expander level.** The Level B–address repeater in the system address controller collects and broadcasts address requests to and from the two boards. It sends global address transactions to other expanders through the Sun Fireplane interconnect address-and-response crossbars.
- **Sun Fireplane interconnect level.** The 18x18 Sun Fireplane interconnect address-and-response crossbars connect the 18 system address controllers together.

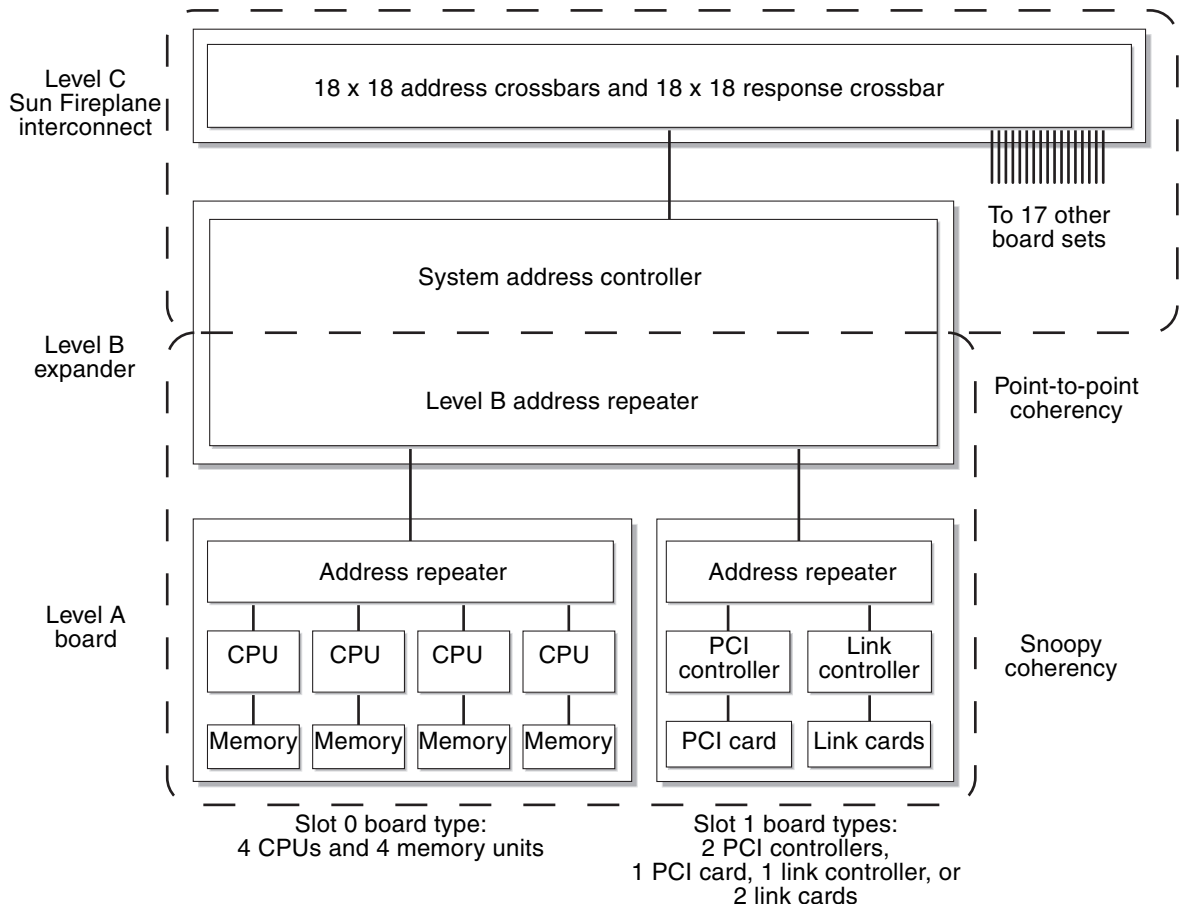

FIGURE 4-3 Address Interconnect Levels

An address passes through five chips to get from a CPU to a memory controller on another board. Addresses going to memory on the same board set do not consume any Sun Fireplane interconnect address bandwidth.

---

## 4.3 Data Interconnect

The Sun Fire E25K/E20K data interconnect has four levels of chips. (See [FIGURE 4-4](#).)

**Level 0—CPU/Memory level.** The five-port dual CPU data switch connects two CPU/Memory pairs to the board data switch. A CPU and a memory unit each have a 2.4 Gbyte/sec connection and share a 4.8 Gbyte/sec connection to the board data switch with the second CPU and memory unit.

**Level 1—Board level.** The three-port board data switch connects the on-board CPUs or I/O interfaces to the expander data switch. Slot 0 boards have a 4.8 Gbyte/sec switch, and slot 1 boards have a 1.2-Gbyte per second and a 2.4 Gbyte/sec switch.

**Level 2—Expander level.** The three-port system data interface connects two boards to the system data crossbar. The slot 0 board (four CPUs and memory) has a 4.8 Gbyte/sec connection, and the slot 1 board (hsPCI) has a 2.4 Gbyte/sec connection.

**Level 3—Sun Fireplane interconnect level.** The 18x18 Sun Fireplane interconnect crossbar is 32 bytes wide with a system bisection bandwidth of 43 Gbyte/sec.

Data passes through seven chips to get from memory on one board to a CPU on another board. Accesses going to memory on the same board set do not consume any Sun Fireplane interconnect data bandwidth.

The numbers in [FIGURE 4-4](#) refer to the peak bandwidth at each level. All data paths are bidirectional. The bandwidth on each path is shared between traffic going into a functional unit and traffic going out of a functional unit.

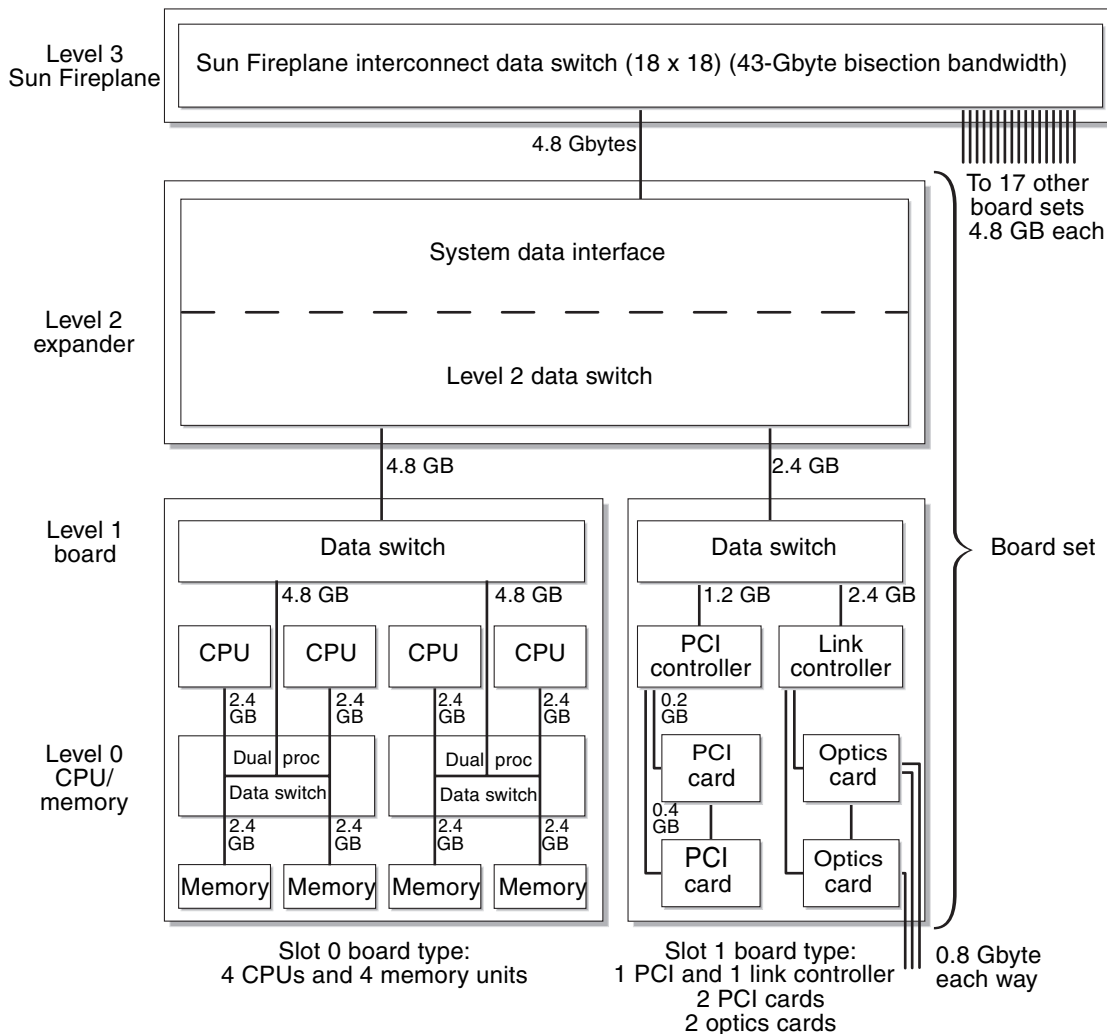

Gbyte numbers are peak bandwidths at each part of the interconnect.

**FIGURE 4-4** Data Interconnect Levels

## 4.4 Interconnect Bandwidth

This section briefly quantifies the interconnect latency and bandwidth of the Sun Fire E25K/E20K systems. Bandwidth is the rate at which a stream of data is delivered. TABLE 4-2 shows the peak memory bandwidths, as limited by the interconnect implementation. Memory is assumed to be interleaved 16 ways across the four memory units on one board.

**TABLE 4-2** Peak Interconnect Bandwidth

Memory Access	Sun Fire E25K System Memory Bandwidth	Sun Fire E20K System Memory Bandwidth
Same CPU as requester	9.6 Gbyte/sec x number of board sets, 172.8 Gbyte/sec maximum for 18 board sets	9.6 Gbyte/sec x number of board sets, 86.4 Gbyte/sec maximum for 9 board sets
Same board as requester	6.7 Gbyte/sec x number of board sets, 120.6 Gbyte/sec maximum for 18 board sets	6.7 Gbyte/sec x number of board sets, 60.3 Gbyte/sec maximum for 9 board sets
Separate board from requester	2.4 Gbyte/sec x number of board sets, 43.2 Gbyte/sec maximum for 18 board sets	2.4 Gbyte/sec x number of board sets, 21.6 Gbyte/sec maximum for 9 board sets
Random data location	47.0 Gbyte/sec	23.5 Gbyte/sec

**Same-board peak bandwidth:** These cases occur when all memory accesses go to memory on the same board as the requester.

The maximum same-board bandwidth is 9.6 Gbytes/sec per board. This occurs when one of the following takes place:

- All CPUs access their own local memory.
- All CPUs access the memory of the other CPU in their pair.
- Two CPUs access their local memory, and two access memory on the other half of the board.

The minimum same-board peak bandwidth is 4.8 Gbyte/sec per board. This occurs when all four CPUs access memory on the other half of the board. When memory is interleaved 16 ways (the normal case), the peak bandwidth is 6.7 Gbytes per second per board.

**Off-board bandwidth:** The off-board data path is 32 bytes wide x 150 MHz, which equals 4.8 Gbyte/sec. Because this bandwidth serves both outgoing requests from the board CPUs and incoming requests for memory from other CPUs, the per-board bisection bandwidth is halved, to 2.4 Gbyte/sec.

## 4.5 Interconnect Latency

Latency is the time for a single data item to be delivered from memory to a CPU. Several kinds of latency can be calculated or measured. Two latencies are described as follows:

- Pin-to-pin latency: Calculated from the interconnect logic cycles. It is independent of what the CPU does with the data.
- Back-to-back load latency: Measured by a kernel of the lmbench benchmark.

These latency numbers represent the best-case example for a single CPU accessing memory.

Pin-to-pin latency is calculated by counting clocks in the interconnect logic design between the address request from a CPU and the completion of the data transfer back into the CPU. (See [TABLE 4-3](#) and [TABLE 4-4](#).)

**TABLE 4-3** Pin-to-Pin Latency for Data in Memory

Location of Memory	Clock Count	CDC <sup>1</sup> Hit	Increase Latency Conditions <sup>2</sup>
Same board (requester local memory)	180 ns, 27 clocks	—	
Same board (other CPU on the same dual CPU data switch)	193 ns, 29 clocks	—	
Same board (other side of data switch)	207 ns, 31 clocks	—	
Other board	333 ns, 50 clocks	Yes	2, 3
	440 ns, 66 clocks	No	3

1 Coherency directory cache

2 Condition 1	Data is coming from slot 1 (I/O or dual CPU board).	1 cycle	7 ns
Condition 2	Data is going to slot 1 (I/O or dual CPU board).	2 cycles	13 ns
Condition 3	Address is coming from or going to a shared board set.	2 cycles	13 ns
Condition 4	Slave address is coming from or going to a shared board set.	2 cycles	13 ns
Condition 5	Home response is from or to a shared board set on CDC miss.	2 cycles	13 ns
Condition 6	Slave response is from or to a shared board set on CDC miss.	2 cycles	13 ns

**TABLE 4-4** Pin-to-Pin Latency for Data in Cache

Location of Cache	Clock Count	CDC <sup>1</sup> Hit	Increase Latency Conditions <sup>2</sup>
On requester board (Sun Fire E25K/E20K: requester on home board set)	280 ns, 42 clocks	—	
On home board	407 ns, 61 locks	Yes	1, 2, 3
	440 ns, 66 clocks	No	3, 5
On another board	473 ns, 71 clocks	Yes	1, 2, 3, 4
	553 ns, 83 clocks	No	3, 4, 6

1 Coherency directory cache

2 Condition 1	Data is coming from slot 1 (I/O or dual CPU board).	1 cycle	7 ns
Condition 2	Data is going to slot 1 (I/O or dual CPU board).	2 cycles	13 ns
Condition 3	Address is coming from or going to a shared board set.	2 cycles	13 ns
Condition 4	Slave address is coming from or going to a shared board set.	2 cycles	13 ns
Condition 5	Home response is from or to a shared board set on CDC miss.	2 cycles	13 ns
Condition 6	Slave response is from or to a shared board set on CDC miss.	2 cycles	13 ns



# System Components

The sections in this chapter describes the major components used in the Sun Fire E25K/E20K systems (FIGURE 5-1).

- Section 5.1, "Cabinets" on page 5-2
- Section 5.2, "Centerplanes" on page 5-4
- Section 5.3, "System Boards" on page 5-6

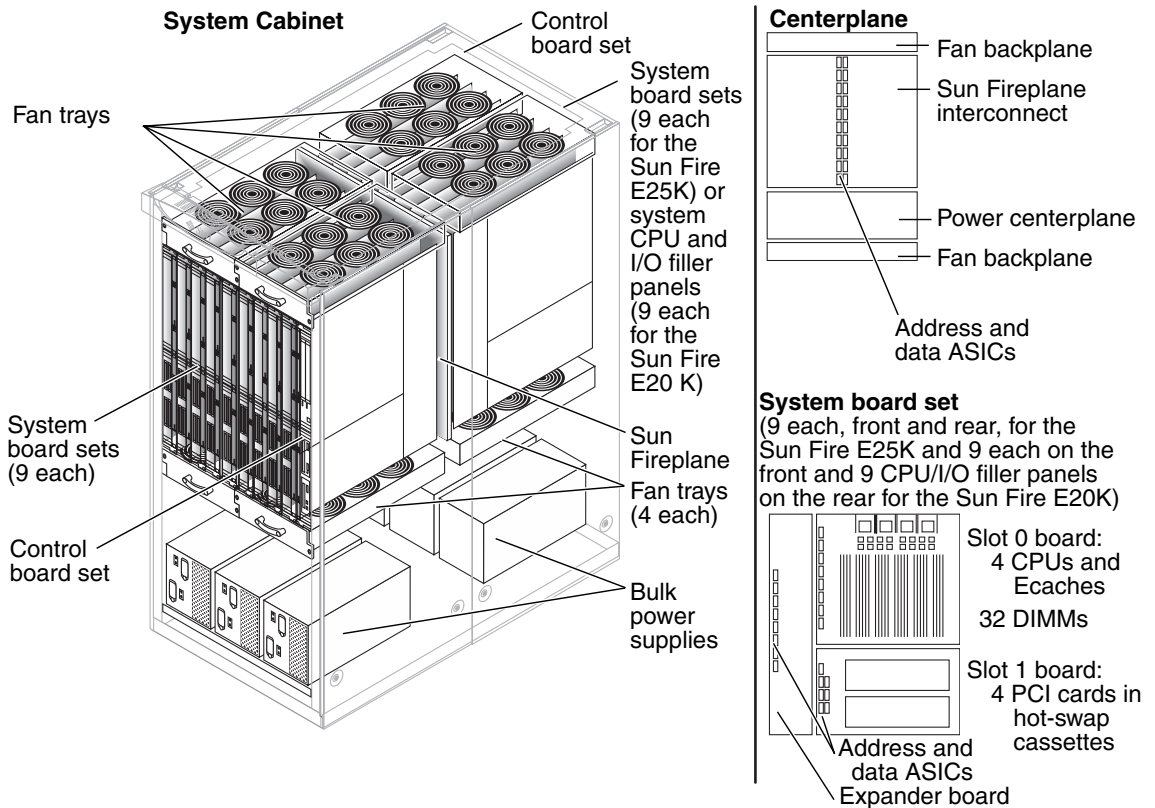

FIGURE 5-1 Sun Fire E25K/E20K Systems Major Components

## 5.1 Cabinets

The Sun Fire E25K/E20K systems can consist of two or more air-cooled cabinets: a system cabinet and one or more customer-selected I/O expansion racks (FIGURE 5-2). The system cabinet includes the CPU/Memory and system control peripherals, such as PCIs.

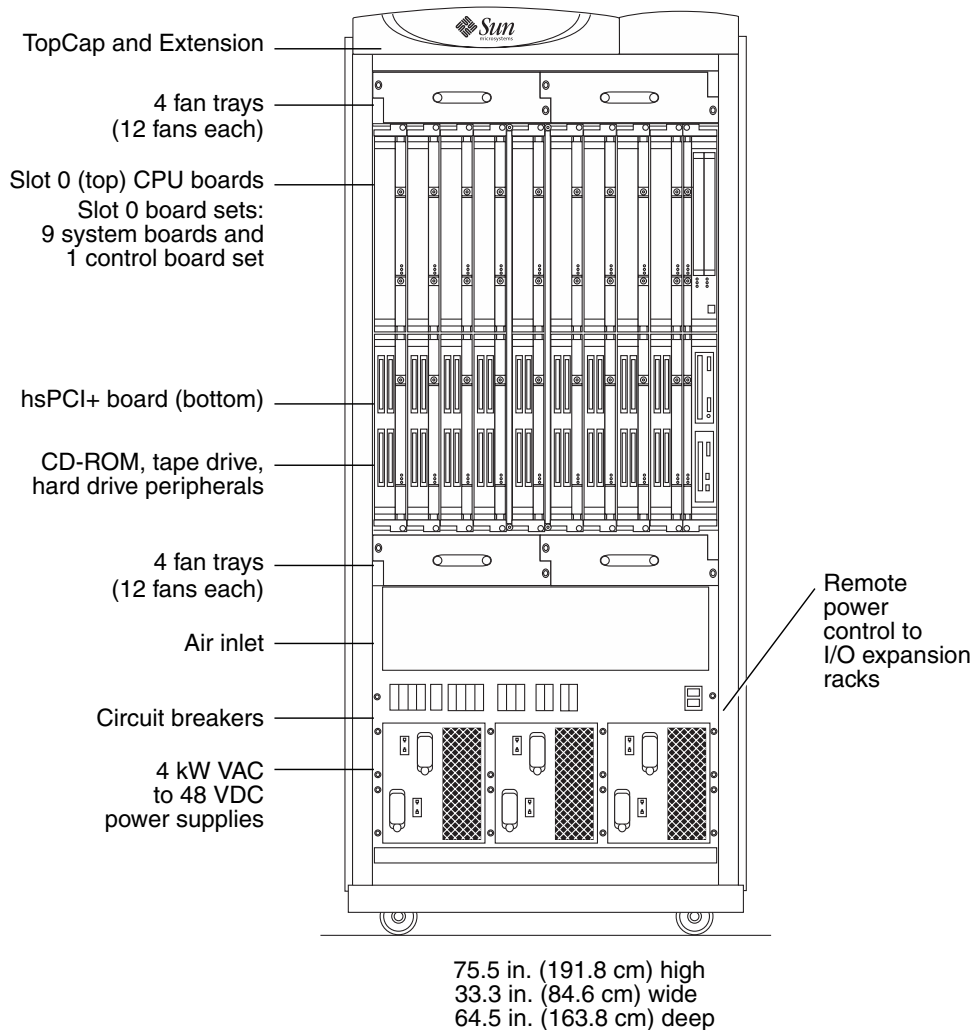

FIGURE 5-2 Sun Fire E25K/E20K Systems Cabinet—Front View

The system cabinet is configured with a full complement of eight fan trays, six bulk power supplies, and two System Control board sets, which perform RAS services. (See [Section 5.3.2, “Controller Board Set”](#) on page 5-11.)

In the Sun Fire E25K system, up to 18 system board sets can be configured to determine the number of CPUs and the amount of memory per system. In the Sun Fire E20K system, up to 9 system board sets can be configured to determine the number of CPUs and the amount of memory per system. (See [Section 5.3.1, “System Board Set”](#) on page 5-7.)

A fully loaded Sun Fire E25K system cabinet weighs 2,467.8 lbs (1,121.7 kg). A fully loaded Sun Fire E20K system cabinet weighs 2141.0 lbs (987.0 kg).

## 5.1.1 System Power

The Sun Fire E25K systems run 200–240 VAC, single-phase power with a frequency of 47 to 63 Hz. The system cabinets require twelve 30A circuits, which are usually connected to two separate power sources. In North America and Japan, the site power receptacles are NEMA L6-30P; otherwise, they are IEC 309. The power cables that go between the system and the facility power receptacles are supplied with the system.

The system cabinets use six dual-input 4-kW dual AC–DC bulk power supplies. Two power cables go to each supply. These supplies convert the input power to 48 VDC. These systems can run with a failed bulk power supply, and the bulk power supplies can be replaced while the system is in operation.

Power is distributed to the individual boards through separate DC circuit breakers. Each board has its own on-board voltage converters, which transform 48 VDC to the levels required by the on-board logic components. Failure of a DC-to-DC converter affects only that particular system board.

## 5.1.2 System Cooling

The only operating environment limitations of the Sun Fire E25K/E20K systems are:

- Temperature: 50–90 °F (10–35 °C)
- Humidity: 20%–80%
- Altitude: up to 10,000 ft (3,048 m)

The fully loaded systems draw 24 kW of power and have an air conditioning load of approximately 81,352 BTU/hour for the Sun Fire E25K system and approximately 44,081 BTU/hour for the Sun Fire E20K system. Smaller configurations draw less power.

For single Sun Fire E25K system or single Sun Fire E20K system heat dissipation, each system needs perforated tiles under the unit. Each tile must be capable of delivering 600 cubic feet per minute of cooling air. Rows of fully loaded system cabinets can be located adjacent to each other. Refer to the *Sun Fire E25K/E20K Systems Site Planning Guide* for further details.

The air goes in through air inlets in the bottom, front, and back of the system cabinet and out through the top. Four fan trays are located above the system boards, and four are located below. The fans have three speeds and normally run at high speed. If any of the components get too hot, the fans are switched to high speed. The system is capable of running with a failed fan, and the fan trays can be hot-swapped while the system is running.

---

## 5.2 Centerplanes

**FIGURE 5-3** shows how the boards and fan trays on one side of a Sun Fire E25K/E20K systems connect into the fan backplane, the power centerplane, and the Sun Fireplane interconnect.

A slot 0 board and a slot 1 board connect into a system carrier plate with an expander board, which in turn connects into the Sun Fireplane interconnect. This unit is called a *board set*. (See [Section 5.3, “System Boards”](#) on page 5-6.)

Nine system board sets connect into each side of the Sun Fireplane interconnect with a system carrier plate and the expander, slot 0 through 8 (front side) and slot 9 through 17 (rear side) of the Sun Fire E25K system. Nine system board sets connect into the front side of the Sun Fireplane interconnect with a system carrier plate and an expander, slot 0 through 8 and nine CPU and I/O filler panels slide into slot 9 through 17 (rear side) of the Sun Fire E20K system. Two system controller board sets (System Control board and System Control peripheral board) connect into each side of the Sun Fireplane interconnect with the system control carrier plate and the centerplane support board, slot SC0 (front side) and slot SC1 (rear side) on both systems. Power is distributed to all board sets through the power centerplane which is located beneath the Sun Fireplane interconnect.

The Sun Fireplane interconnect has two dedicated slots (both on the right side, front and rear) for the system controller board sets. These board sets contain power, clock, and JTAG support for the Sun Fireplane interconnect ASICs and hold the System Control boards and their associated peripherals (CD-ROM, tape drive, and hard drive).

Two fan backplanes are mounted above the Sun Fireplane interconnect, and Two are mounted below the power centerplane, distributing power to the eight fan trays.

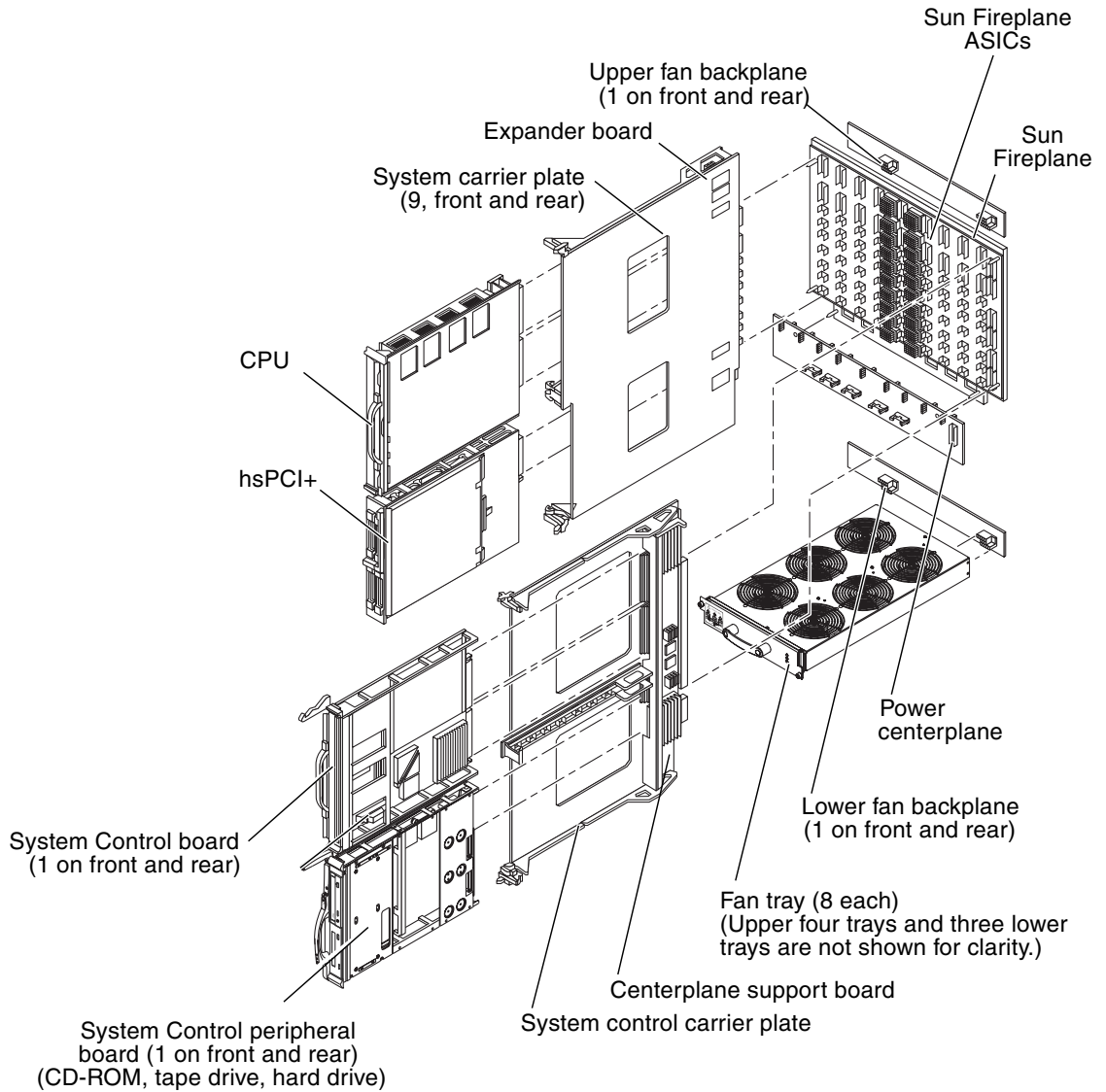

**FIGURE 5-3** Sun Fireplane Interconnect and Other Components

## 5.2.1 Sun Fireplane Interconnect

The Sun Fireplane interconnect is the heart of the Sun Fire E25K/E20K and provides a peak data bandwidth of 43 Gbyte/sec among the 18 board sets. The Sun Fireplane interconnect also delivers a console bus and an Ethernet connection to each board set.

The Sun Fireplane interconnect contains three 18x18 crossbars. The 18x18 address crossbar provides a path for address transactions between the address extender queue (AXQ) ASIC on each expander board. A pair of unidirectional paths goes to each expander board, one sending and one receiving. Each address transaction takes two system-interconnect cycles (13.3 ns) to be transmitted across the address crossbar.

The 18x18 response crossbar provides a reply path between the AXQ ASIC on each expander board. Each response message takes either one or two system-interconnect cycles (6.7 ns or 13.3 ns), depending on the type. The response path is half the width of the address path. A pair of unidirectional paths goes to each expander board, one sending and one receiving.

The 18x18 data crossbar moves cache-line (72-byte-wide) packets between the system data interface (SDI) ASICs on each expander board. Each connection is a bidirectional 36-byte-wide path. The bandwidth is 18 slots x 32-byte path x 150 MHz divided by two for bidirectional paths that are equal to 43.2 Gbyte/sec. To maximize the use of these bidirectional paths, the data multiplexer (DMX) ASICs queue received data.

---

## 5.3 System Boards

A board set is a combination of three system boards that connect into the Sun Fireplane interconnect. It is also called an expander. There are two types of board sets:

- **System board set:** Boards with CPU/Memory, PCI bus controllers, and optical link controllers. (See [Section 5.3.1, “System Board Set”](#) on page 5-7.)
- **Controller board set:** Boards with power, clock, and JTAG support for the Sun Fireplane interconnect, system controller boards, and their associated peripherals. (See [Section 5.3.2, “Controller Board Set”](#) on page 5-11.)

## 5.3.1 System Board Set

A system board set is a combination of three boards: an expander board, a slot 0 board, and a slot 1 board. The board set, as a unit, *cannot be hot-swapped* from the Sun Fireplane interconnect. Due to the weight of the components, the slot 0 and slot 1 boards are individually removed first, and then the expander and its carrier plate can be hot-swapped. The individual slot 0 and slot 1 boards can be hot-swapped from the expander.

Slot 0 boards have a 4.8 Gbyte/sec off-board data port. They are the primary locations of CPUs and are the only location of memory in a Sun Fire E25K/E20K systems. Only one Slot 0 board type is used in the Sun Fire E25K/E20K systems.

Slot 1 boards have a 2.4 Gbyte/sec off-board data port. The hsPCI+ is a slot 1 type board which is unique to Sun Fire E25K/E20K systems and Sun Fire 15K/12K systems.

### 5.3.1.1 Expander Board

An expander board acts as a 2:1 MUX to expand a Sun Fireplane interconnect slot so that it accommodates the slot 0 and slot 1 type boards. The expander board provides a level-2 address bus that can do 150 million snoops per second. The AXQ on the expander board recognizes addresses targeted at other board sets and transmits them across the Sun Fireplane interconnect.

The expander provides a three-port data switch to route data between the slot 0 board, the slot 1 board, and the Sun Fireplane interconnect. This three-port data switch is 36 bytes wide to the Sun Fireplane interconnect and to the slot 0 board, and 18 bytes wide to the slot 1 board. A board set can transfer a maximum rate of 4.8 Gbytes/sec to other board sets.

It is possible to use an expander with only one system board (either slot 0 or slot 1). A system board can be hot-swapped into the expander, tested, and configured into a running system without disturbing the other board. The expander can be hot-swapped and inserted after its two system boards are removed.

### 5.3.1.2 CPU/Memory Board

The CPU/Memory board is a slot 0 board. It contains up to four CPUs and eight external cache DIMMs. Each CPU controls 0, 4, or 8 DIMMs. The maximum possible DIMM size is 2 Gbyte, which is 64 Gbyte of memory per board. DIMMs must be the same size and must not have sizes intermixed on a board. All CPUs on the board must be the same speed.

Two CPU/Memory pairs are connected to the rest of the system through the level-0 dual-CPU data switch. Each CPU/Memory can transfer data at a maximum rate of 2.4 Gbytes/sec. The pair of CPU/Memory units share a 4.8 Gbyte/sec port to the data switch. The level-1 data switch connects the two pairs of CPUs to the off-board data port that goes to the expander board. (See [FIGURE 5-4](#).)

### 5.3.1.3 Example of System Board Set

[FIGURE 5-4](#) and [FIGURE 5-5](#) show an example board set diagram and board set layout composed of an expander board, a CPU/Memory board, and a PCI board.

### 5.3.1.4 PCI Assembly (hsPCI+)

The PCI assembly is a slot 1 option board. It is also called the hsPCI+ assembly. It provides four standard PCI slots, one at 33 MHz and three at 33/66 MHz. The assembly has two PCI controllers, each of which provides a 33/66 MHz PCI bus, except for one slot that it is permanently set to 33Mhz.

A cassette is used to provide hot-swap capabilities for industry-standard PCI assemblies. The cassette is a passive card carrier that adapts the standard PCI pins to a connector.

A PCI card is placed into a PCI hot-swap cassette, and then the cassette is hot-swapped onto the PCI assembly. The software recognizes this assembly as a standard PCI assembly with the system controller turning power on and off to each PCI slot. (See [FIGURE 5-4](#).)



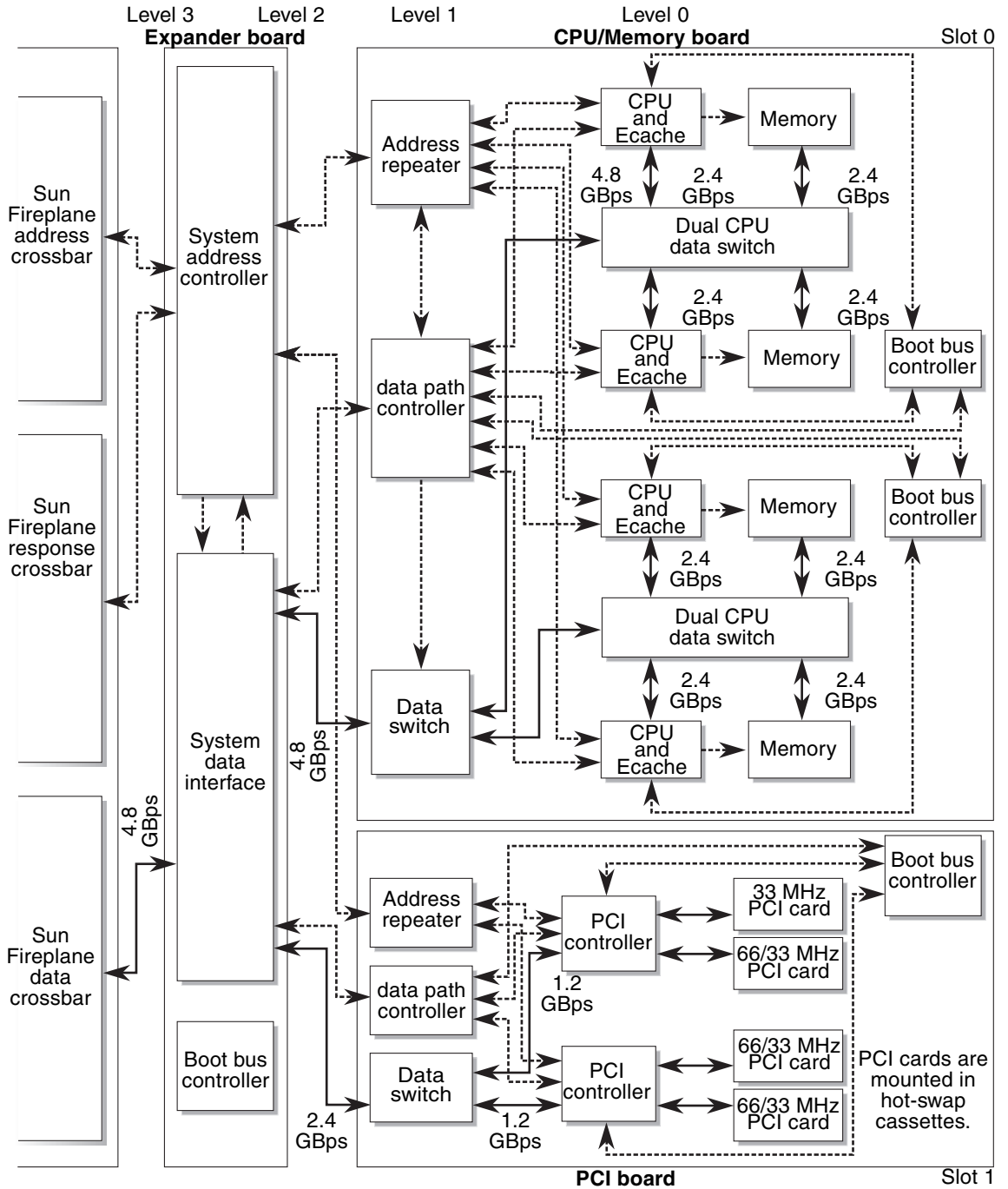
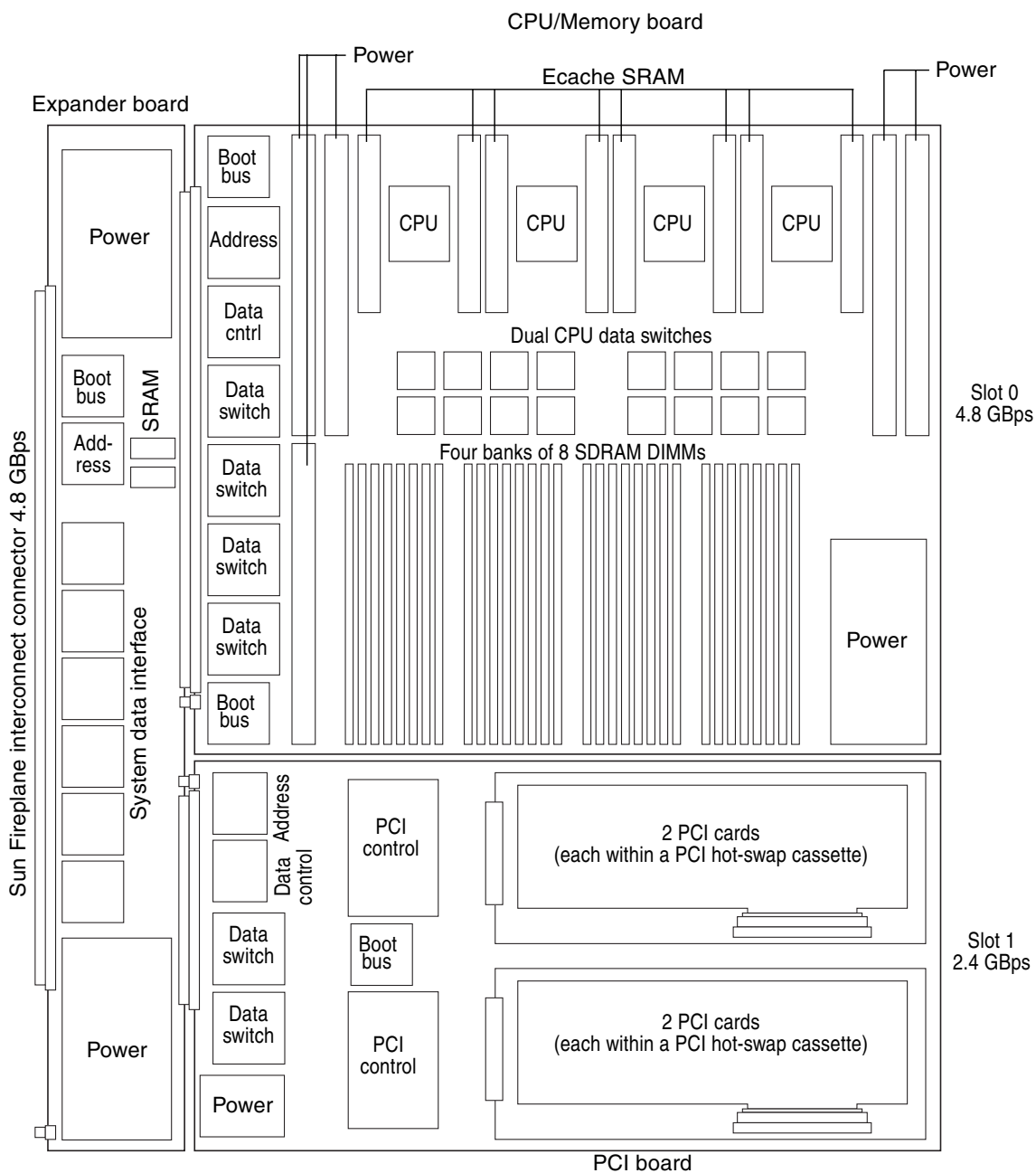

FIGURE 5-4 Board Set Block Diagram



**FIGURE 5-5** System Board Set Layout

## 5.3.2 Controller Board Set

The controller board set provides critical services and resources required for operation and control of the Sun Fire E25K/E20K systems (FIGURE 5-6).

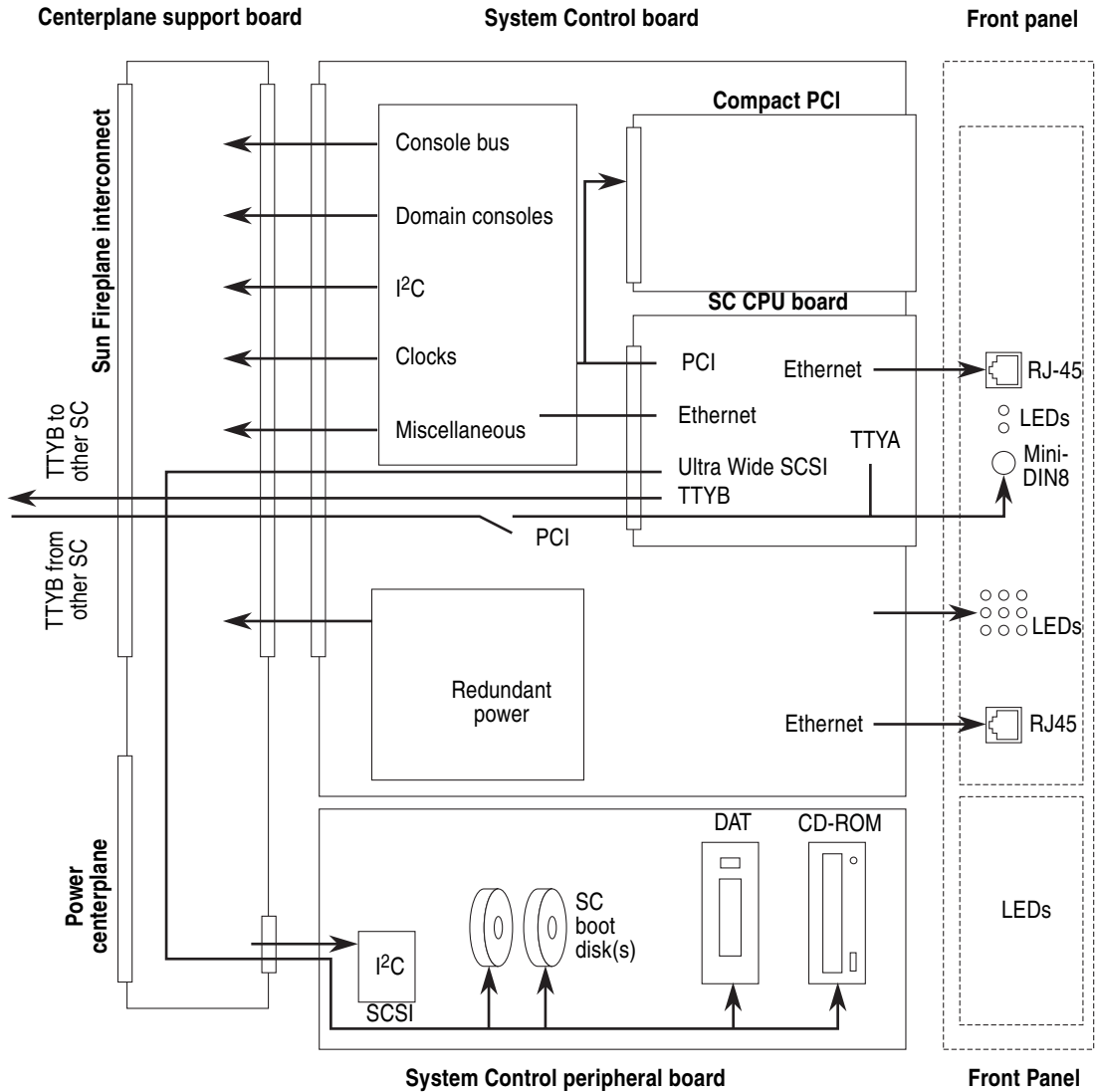

FIGURE 5-6 System Controller Board Layout

This board set consists of three boards:

- **Centerplane support board:** Connects into a dedicated Sun Fireplane interconnect slot and is the same size as an expander board with power, clock, and JTAG support for the Sun Fireplane interconnect.
- **System Control board:** Connects into the centerplane support board and is the same size as a slot 0 system board.
- **System Control Peripheral board:** Connects into the centerplane support board and is the same size as a slot 1 system board. This peripheral board holds a CD-ROM, disk drives, and a 4-mm format digital audio tape (DAT) drive.

The System Control board is a two-board combination:

- **SC CPU board.** The SC CPU board is an off-the-shelf SPARCengine Netra 2140 6U cPCI board with an UltraSPARC-III embedded system. This board runs Solaris software, the System Management software, and all associated applications required for startup, maintenance, and interrogation of the system.
- **System Control board.** The control board provides the Sun Fire E25K/E20K systems with specific logic and connection to the centerplane support board.

The system controller board set provides the following critical services and resources required for operation and control of the Sun Fire E25K/E20K systems:

- System clock
- I<sup>2</sup>C bus to the entire system
- Console bus to the entire system
- Serial (TTY) port through the SC CPU board
- Serial (TTY) port between the two system controllers
- Netra 2140 Compact PCI to run Solaris software, System Management software, and all associated applications required for bringup, maintenance, and interrogation of the system
- Exclusive access to all dynamic system domain consoles
- SCSI to support DVD-ROM, DAT drives, and hard drives
- Support of high-availability features for failover of SC operations to the redundant SC
- Support of security features to provide a secure administrative environment up to and including certified B1 security
- Secure private Ethernet lines to all I/O boards on each expander management area network (MAN)

The SPARCengine cPCI+ card is mounted flat and on top of the SC in the same manner that the PCI cards are mounted onto the I/O boards.

# Glossary

---

---

## A

**address repeater  
(AR) ASIC**

Used on slot 0 and slot 1 boards to implement the on-board system address bus. Connects four CPUs (or two I/O controllers) to the address controller on the expander board.

**automatic system  
recovery (ASR)**

The ability of a system to recover automatically in the event of a hardware failure. Identifies and isolates a failing hardware component, and builds a bootable system configuration without the failed hardware component.

---

## B

**board set (expander)**

The combination of an expander board, a slot 0 board, and a slot 1 board.

**boot bus controller  
(SBBC) ASIC**

Used on slot 0 and slot 1 boards to provide a console-bus-slave interface to PROM bus, JTAG, and I<sup>2</sup>C devices for board initialization. When used with CPUs, provides a boot-bus path to POST code.

---

## C

- CDC** Coherency directory cache inside the system address controller (AXQ) ASIC. Caches recent memory tag states stored in the ECC bits of memory to speed up accesses to cache lines on other boardsets.
- concurrent service** The ability to service various parts of a machine without interfering with a running system.
- Control board** Connects into one of two control slots on the Sun Fireplane interconnect. Consists of a centerplane support board, a System Control board, and a peripheral board.
- CPU/Memory board** A slot 0 board that holds four CPUs, each of which controls eight DIMMs. The CPU/Memory board has an off-board bandwidth of 4.8 Gbyte/sec.

---

## D

- data arbiter (DARB) ASIC** Used on the Sun Fireplane interconnect to control the 18x18 data crossbar.
- data multiplexer (DMX) ASIC** An 18x18 data crossbar that connects the system data interfaces on each expander board to the Sun Fireplane interconnect.
- data path controller (SDC) ASIC** Used on the slot 0 and slot 1 boards to controls the on-board system data path. Repeats the console bus to the two on-board boot-bus controllers.
- data switch (DX) ASIC** Used on the slot 0 and slot 1 boards to connect the on-board system data path to the off-board system data path.
- DCDS** A dual-CPU data switch ASIC that connects two CPUs and two memory units to the data switch ASIC.
- domain set** The combination of an SRD and its client domains.
- domainstop** Error isolation between client domains.
- dynamic reconfiguration** The process of activating or deactivating devices such as boards and power supplies in a running Solaris operating system while user applications continue.

---

## E

**expander board** A board connecting into the Sun Fireplane interconnect at the slot 0 and slot 1 sockets.

---

## G

**Gbyte/sec (Gbps)** Gigabyte per second of capacity =  $2^{30}$  = 1,073,741,824 bytes

---

## H

**hot-swap** An active device that can be installed and removed from a running system for dynamic reconfiguration.

**hsPCI+ assembly** An assembly that holds one 33-MHz standard PCI card and three 66-MHz standard PCI cards. The PCI cards can be hot-swapped from the I/O slot while the system is in operation for dynamic reconfiguration.

---

## J

**JTAG** Joint Test Action Group. An IEEE standard (1149.1) for serial scanning of chip internal registers.

---

## L

**latency** The time for a single data item to be delivered from memory to a CPU.

**link domains** A linked domain is when a domain is removed from an inter-domain network.

---

## M

**Mbyte** Megabyte of capacity =  $2^{20}$  = 1,048,576 bytes.

---

## P

**PCI controller ASIC** Used on the hsPCI+ board and the link board to connect the system interconnect to one 33-MHz PCI bus and three 66-MHz PCI bus.

**PCI hot-swap cassette** A passive hot-swap carrier that adapts standard PCI pins to connectors.

**power source** The hardware components powered by a group of power supplies.

---

## R

**recordstop** A recordstop is a nonfatal error such as correctable single-bit errors in a data path.

**response multiplexer (RMX) ASIC** An 18x18 crossbar that transmits transaction responses and connects together the address controllers on each expander board.

---

## S

**scalable shared memory (SSM)** A mode of the system interconnect that enables multiple snoopy coherence domains to be connected together.

**split expander** Two system boards in a board set that are in separate domains.

**Sun Fire address bus** Address bus containing a maximum snoop rate of 150 million snoops per second or a 9.6-Gbyte/sec data rate.

**Sun Fireplane interconnect** The interconnect architecture used by the UltraSPARC IV Cu generation of CPUs. This architecture is the physical active-logic centerplane that implements the system address and data crossbars.



<b>Sun Fireplane interconnect architecture</b>	The cache-coherency protocol and set of address transactions that are used by all UltraSPARC IV Cu CPU-based systems.
<b>Sun Fireplane interconnect data path</b>	The point-to-point data protocol used between the DCDS and DX ASICs.
<b>system address controller (AXQ) ASIC</b>	Connects the address repeaters on the slot 0 and the slot 1 boards to the Sun Fireplane interconnect address and response crossbars. Used on expander boards.
<b>system board set</b>	Connects into one of 18 system slots in the Sun Fireplane interconnect with the expander board. Contains slot 0 boards and slot 1 boards.
<b>System Control board set</b>	Connects into one of two system control slots in the Sun Fireplane interconnect with the centerplane support board. This board set contains the System Control board and a system control peripheral board (CD-ROM, tape drive, hard drive).
<b>system data interface (SDI) ASIC</b>	Used on the expander boards to connect the data switches on the slot 0 and the slot 1 boards to the Sun Fireplane interconnect data crossbars.



## U

<b>UltraSPARC CPU.</b>	The UltraSPARC IV Cu CPU is used on the CPU/Memory board.
<b>unlinking domains</b>	Removing a domain from the inter-domain network.

