



Sun Fire™ E25K/E20K Systems

Hardware Installation and De-Installation Guide

Sun Microsystems, Inc.
www.sun.com

Part No. 817-4135-11
April 2004, Revision A

Submit comments about this document at: <http://www.sun.com/hwdocs/feedback>

Copyright 2004 Sun Microsystems, Inc., 4150 Network Circle, Santa Clara, California 95054, U.S.A. All rights reserved.

Sun Microsystems, Inc. has intellectual property rights relating to technology that is described in this document. In particular, and without limitation, these intellectual property rights may include one or more of the U.S. patents listed at <http://www.sun.com/patents> and one or more additional patents or pending patent applications in the U.S. and in other countries.

This document and the product to which it pertains are distributed under licenses restricting their use, copying, distribution, and decompilation. No part of the product or of this document may be reproduced in any form by any means without prior written authorization of Sun and its licensors, if any.

Third-party software, including font technology, is copyrighted and licensed from Sun suppliers.

Parts of the product may be derived from Berkeley BSD systems, licensed from the University of California. UNIX is a registered trademark in the U.S. and in other countries, exclusively licensed through X/Open Company, Ltd.

Sun, Sun Microsystems, the Sun logo, AnswerBook2, docs.sun.com, Sun Fire, SunVTS, Sun Fireplane interconnect, and Solaris are trademarks or registered trademarks of Sun Microsystems, Inc. in the U.S. and in other countries.

All SPARC trademarks are used under license and are trademarks or registered trademarks of SPARC International, Inc. in the U.S. and in other countries. Products bearing SPARC trademarks are based upon an architecture developed by Sun Microsystems, Inc.

The OPEN LOOK and Sun™ Graphical User Interface was developed by Sun Microsystems, Inc. for its users and licensees. Sun acknowledges the pioneering efforts of Xerox in researching and developing the concept of visual or graphical user interfaces for the computer industry. Sun holds a non-exclusive license from Xerox to the Xerox Graphical User Interface, which license also covers Sun's licensees who implement OPEN LOOK GUIs and otherwise comply with Sun's written license agreements.

U.S. Government Rights—Commercial use. Government users are subject to the Sun Microsystems, Inc. standard license agreement and applicable provisions of the FAR and its supplements.

DOCUMENTATION IS PROVIDED "AS IS" AND ALL EXPRESS OR IMPLIED CONDITIONS, REPRESENTATIONS AND WARRANTIES, INCLUDING ANY IMPLIED WARRANTY OF MERCHANTABILITY, FITNESS FOR A PARTICULAR PURPOSE OR NON-INFRINGEMENT, ARE DISCLAIMED, EXCEPT TO THE EXTENT THAT SUCH DISCLAIMERS ARE HELD TO BE LEGALLY INVALID.

Copyright 2004 Sun Microsystems, Inc., 4150 Network Circle, Santa Clara, Californie 95054, Etats-Unis. Tous droits réservés.

Sun Microsystems, Inc. a les droits de propriété intellectuels relatants à la technologie qui est décrit dans ce document. En particulier, et sans la limitation, ces droits de propriété intellectuels peuvent inclure un ou plus des brevets américains énumérés à <http://www.sun.com/patents> et un ou les brevets plus supplémentaires ou les applications de brevet en attente dans les Etats-Unis et dans les autres pays.

Ce produit ou document est protégé par un copyright et distribué avec des licences qui en restreignent l'utilisation, la copie, la distribution, et la décompilation. Aucune partie de ce produit ou document ne peut être reproduite sous aucune forme, par quelque moyen que ce soit, sans l'autorisation préalable et écrite de Sun et de ses bailleurs de licence, s'il y en a.

Le logiciel détenu par des tiers, et qui comprend la technologie relative aux polices de caractères, est protégé par un copyright et licencié par des fournisseurs de Sun.

Des parties de ce produit pourront être dérivées des systèmes Berkeley BSD licenciés par l'Université de Californie. UNIX est une marque déposée aux Etats-Unis et dans d'autres pays et licenciée exclusivement par X/Open Company, Ltd.

Sun, Sun Microsystems, le logo Sun, AnswerBook2, docs.sun.com, Sun Fire, SunVTS, Sun Fireplane interconnect, et Solaris sont des marques de fabrique ou des marques déposées de Sun Microsystems, Inc. aux Etats-Unis et dans d'autres pays.

Toutes les marques SPARC sont utilisées sous licence et sont des marques de fabrique ou des marques déposées de SPARC International, Inc. aux Etats-Unis et dans d'autres pays. Les produits portant les marques SPARC sont basés sur une architecture développée par Sun Microsystems, Inc.

L'interface d'utilisation graphique OPEN LOOK et Sun™ a été développée par Sun Microsystems, Inc. pour ses utilisateurs et licenciés. Sun reconnaît les efforts de pionniers de Xerox pour la recherche et le développement du concept des interfaces d'utilisation visuelle ou graphique pour l'industrie de l'informatique. Sun détient une licence non exclusive de Xerox sur l'interface d'utilisation graphique Xerox, cette licence couvrant également les licenciées de Sun qui mettent en place l'interface d'utilisation graphique OPEN LOOK et qui en outre se conforment aux licences écrites de Sun.

LA DOCUMENTATION EST FOURNIE "EN L'ÉTAT" ET TOUTES AUTRES CONDITIONS, DECLARATIONS ET GARANTIES EXPRESSES OU TACITES SONT FORMELLEMENT EXCLUES, DANS LA MESURE AUTORISEE PAR LA LOI APPLICABLE, Y COMPRIS NOTAMMENT TOUTE GARANTIE IMPLICITE RELATIVE A LA QUALITE MARCHANDE, A L'APTITUDE A UNE UTILISATION PARTICULIERE OU A L'ABSENCE DE CONTREFAÇON.



Contents

- Preface** **xxiii**

- 1. Preparing for Sun Fire E25K/E20K Systems Installation** **1-1**
 - 1.1 Safety Precautions 1-1
 - 1.2 Site Preparation 1-4

- 2. Installing the Sun Fire E25K/E20K Systems Hardware** **2-1**
 - 2.1 Tools Required 2-1
 - 2.2 Connecting Power Cables 2-2
 - 2.3 Grounding the Cabinet 2-4
 - 2.4 Connecting the System Controller 2-7
 - 2.5 Connecting the Network Hardware 2-7
 - 2.6 Labeling the I/O Cables 2-8
 - 2.7 Completing the Installation 2-9
 - 2.8 Powering On the System 2-10

- 3. Installing the Sun Fire E25K/E20K Systems Software** **3-1**
 - 3.1 Initial Domain Configuration 3-1
 - 3.2 Running SunVTS on the Host 3-3

- 4. De-installing Sun Fire E25K/E20K Systems** **4-1**

- 4.1 Backing Up Your System 4-1
- 4.2 Deconfiguring the Domains 4-1
- 4.3 Preparing to Move the Cabinet 4-3
- 4.4 Preparing the Cabinet 4-4
- 4.5 Crating the Cabinet 4-5
- 4.6 Completing the Packaging 4-10

Index Index-1

Figures

- [FIGURE 2-1](#) AC Power Cord Installation 2–3
- [FIGURE 2-2](#) Sun Fire E25K/E20K Systems Grounding 2–4
- [FIGURE 2-3](#) System Board Power and ESD Connections 2–5
- [FIGURE 2-4](#) Ground Cable Attachment Point at System Cabinet 2–6
- [FIGURE 2-5](#) Cable Label Example 2–8
- [FIGURE 2-6](#) Circuit Breakers and Power Supplies 2–10
- [FIGURE 4-1](#) Retracted Leveling Feet 4–4
- [FIGURE 4-2](#) Cabinet Kick Plate Assembly Removal 4–6
- [FIGURE 4-3](#) Installed Ramps on Pallet Deck 4–7
- [FIGURE 4-4](#) Cabinet on Shipping Pallet Deck 4–8
- [FIGURE 4-5](#) Final Packaging and Outside Carton Packaging Assemblies 4–10
- [FIGURE 4-6](#) Cabinet Ready for Shipping 4–11

Regulatory Compliance Statements

Your Sun product is marked to indicate its compliance class:

- Federal Communications Commission (FCC) — USA
- Industry Canada Equipment Standard for Digital Equipment (ICES-003) — Canada
- Voluntary Control Council for Interference (VCCI) — Japan
- Bureau of Standards Metrology and Inspection (BSMI) — Taiwan

Please read the appropriate section that corresponds to the marking on your Sun product before attempting to install the product.

FCC Class A Notice

This device complies with Part 15 of the FCC Rules. Operation is subject to the following two conditions:

1. This device may not cause harmful interference.
2. This device must accept any interference received, including interference that may cause undesired operation.

Note: This equipment has been tested and found to comply with the limits for a Class A digital device, pursuant to Part 15 of the FCC Rules. These limits are designed to provide reasonable protection against harmful interference when the equipment is operated in a commercial environment. This equipment generates, uses, and can radiate radio frequency energy, and if it is not installed and used in accordance with the instruction manual, it may cause harmful interference to radio communications. Operation of this equipment in a residential area is likely to cause harmful interference, in which case the user will be required to correct the interference at his own expense.

Modifications: Any modifications made to this device that are not approved by Sun Microsystems, Inc. may void the authority granted to the user by the FCC to operate this equipment.

FCC Class B Notice

This device complies with Part 15 of the FCC Rules. Operation is subject to the following two conditions:

1. This device may not cause harmful interference.
2. This device must accept any interference received, including interference that may cause undesired operation.

Note: This equipment has been tested and found to comply with the limits for a Class B digital device, pursuant to Part 15 of the FCC Rules. These limits are designed to provide reasonable protection against harmful interference in a residential installation. This equipment generates, uses and can radiate radio frequency energy and, if not installed and used in accordance with the instructions, may cause harmful interference to radio communications. However, there is no guarantee that interference will not occur in a particular installation. If this equipment does cause harmful interference to radio or television reception, which can be determined by turning the equipment off and on, the user is encouraged to try to correct the interference by one or more of the following measures:

- Reorient or relocate the receiving antenna.
- Increase the separation between the equipment and receiver.
- Connect the equipment into an outlet on a circuit different from that to which the receiver is connected.
- Consult the dealer or an experienced radio/television technician for help.

Modifications: Any modifications made to this device that are not approved by Sun Microsystems, Inc. may void the authority granted to the user by the FCC to operate this equipment.

ICES-003 Class A Notice - Avis NMB-003, Classe A

This Class A digital apparatus complies with Canadian ICES-003.

Cet appareil numérique de la classe A est conforme à la norme NMB-003 du Canada.

ICES-003 Class B Notice - Avis NMB-003, Classe B

This Class B digital apparatus complies with Canadian ICES-003.

Cet appareil numérique de la classe B est conforme à la norme NMB-003 du Canada.

VCCI 基準について

クラス A VCCI 基準について

クラス A VCCI の表示があるワークステーションおよびオプション製品は、クラス A 情報技術装置です。これらの製品には、下記の項目が該当します。

この装置は、情報処理装置等電波障害自主規制協議会 (VCCI) の基準に基づくクラス A 情報技術装置です。この装置を家庭環境で使用すると電波妨害を引き起こすことがあります。この場合には使用者が適切な対策を講ずるよう要求されることがあります。

クラス B VCCI 基準について

クラス B VCCI の表示  があるワークステーションおよびオプション製品は、クラス B 情報技術装置です。これらの製品には、下記の項目が該当します。

この装置は、情報処理装置等電波障害自主規制協議会 (VCCI) の基準に基づくクラス B 情報技術装置です。この装置は、家庭環境で使用することを目的としていますが、この装置がラジオやテレビジョン受信機に近接して使用されると、受信障害を引き起こすことがあります。取扱説明書に従って正しい取り扱いをしてください。

BSMI Class A Notice

The following statement is applicable to products shipped to Taiwan and marked as Class A on the product compliance label.

警告使用者：
這是甲類的資訊產品，在居住的環境中使用時，可能會造成射頻干擾，在這種情況下，使用者會被要求採取某些適當的對策。



GOST-R Certification Mark

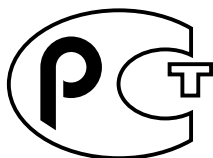

Safety Agency Compliance Statements

Read this section before beginning any procedure. The following text provides safety precautions to follow when installing a Sun Microsystems product.

Safety Precautions

For your protection, observe the following safety precautions when setting up your equipment:

- Follow all cautions and instructions marked on the equipment.
- Ensure that the voltage and frequency of your power source match the voltage and frequency inscribed on the equipment's electrical rating label.
- Never push objects of any kind through openings in the equipment. Dangerous voltages may be present. Conductive foreign objects could produce a short circuit that could cause fire, electric shock, or damage to your equipment.

Symbols

The following symbols may appear in this book:



Caution – There is a risk of personal injury and equipment damage. Follow the instructions.



Caution – Hot surface. Avoid contact. Surfaces are hot and may cause personal injury if touched.



Caution – Hazardous voltages are present. To reduce the risk of electric shock and danger to personal health, follow the instructions.

Depending on the type of power switch your device has, one of the following symbols may be used:



On – Applies AC power to the system.



Off – Removes AC power from the system.



Standby – The On/Standby switch is in the Standby position.

Modifications to Equipment

Do not make mechanical or electrical modifications to the equipment. Sun Microsystems is not responsible for regulatory compliance of a modified Sun product.

Placement of a Sun Product



Caution – Do not block or cover the openings of your Sun product. Never place a Sun product near a radiator or heat register. Failure to follow these guidelines can cause overheating and affect the reliability of your Sun product.

Noise Level

In compliance with the requirements defined in DIN 45635 Part 1000, the workplace-dependent noise level of this product is less than 70 db(A).

SELV Compliance

Safety status of I/O connections comply to SELV requirements.

Power Cord Connection



Caution – Sun products are designed to work with power systems having a grounded neutral (grounded return for DC-powered products). To reduce the risk of electric shock, do not plug Sun products into any other type of power system. Contact your facilities manager or a qualified electrician if you are not sure what type of power is supplied to your building.

Caution – Not all power cords have the same current ratings. Household extension cords do not have overload protection and are not meant for use with computer systems. Do not use household extension cords with your Sun product.

The following caution applies only to devices with a Standby power switch:



Caution – The power switch of this product functions as a standby type device only. The power cord serves as the primary disconnect device for the system. Be sure to plug the power cord into a grounded power outlet that is nearby the system and is readily accessible. Do not connect the power cord when the power supply has been removed from the system chassis.

The following caution applies only to devices with multiple power cords:



Caution – For products with multiple power cords, all power cords must be disconnected to completely remove power from the system.

Battery Warning



Caution – There is danger of explosion if batteries are mishandled or incorrectly replaced. On systems with replaceable batteries, replace only with the same manufacturer and type or equivalent type recommended by the manufacturer per the instructions provided in the product service manual. Do not disassemble batteries or attempt to recharge them outside the system. Do not dispose of batteries in fire. Dispose of batteries properly in accordance with the manufacturer's instructions and local regulations. Note that on Sun CPU boards, there is a lithium battery molded into the real-time clock. These batteries are not customer replaceable parts.

System Unit Cover

You must remove the cover of your Sun computer system unit to add cards, memory, or internal storage devices. Be sure to replace the cover before powering on your computer system.



Caution – Do not operate Sun products without the cover in place. Failure to take this precaution may result in personal injury and system damage.

Rack System Warning

The following warnings apply to Racks and Rack Mounted systems.



Caution – For safety, equipment should always be loaded from the bottom up. That is, install the equipment that will be mounted in the lowest part of the rack first, then the next higher systems, etc.

Caution – To prevent the rack from tipping during equipment installation, the anti-tilt bar on the rack must be deployed.



Caution – To prevent extreme operating temperature within the rack insure that the maximum temperature does not exceed the product's ambient rated temperatures.



Caution – To prevent extreme operating temperatures due to reduced airflow consideration should be made to the amount of air flow that is required for a safe operation of the equipment.

Laser Compliance Notice

Sun products that use laser technology comply with Class 1 laser requirements.

Class 1 Laser Product
Luokan 1 Laserlaitte
Klasse 1 Laser Apparat
Laser Klasse 1

CD and DVD Devices

The following caution applies to CD, DVD, and other optical devices.



Caution – Use of controls, adjustments, or the performance of procedures other than those specified herein may result in hazardous radiation exposure.

Conformité aux normes de sécurité

Veillez lire attentivement cette section avant de commencer. Ce texte traite des mesures de sécurité qu'il convient de prendre pour l'installation d'un produit Sun Microsystems.

Mesures de sécurité

Pour votre sécurité, nous vous recommandons de suivre scrupuleusement les mesures de sécurité ci-dessous lorsque vous installez votre matériel:

- Suivez tous les avertissements et toutes les instructions inscrites sur le matériel.
- Assurez-vous que la tension et la fréquence de votre source d'alimentation correspondent à la tension et à la fréquence indiquées sur l'étiquette de la tension électrique nominale du matériel
- N'introduisez jamais d'objets quels qu'ils soient dans les ouvertures de l'équipement. Vous pourriez vous trouver en présence de hautes tensions dangereuses. Tout objet étranger conducteur risque de produire un court-circuit pouvant présenter un risque d'incendie ou de décharge électrique, ou susceptible d'endommager le matériel.

Symboles

Vous trouverez ci-dessous la signification des différents symboles utilisés:



Attention – Vous risquez d'endommager le matériel ou de vous blesser. Veuillez suivre les instructions.



Attention – Surfaces brûlantes. Évitez tout contact. Les surfaces sont brûlantes. Vous risquez de vous blesser si vous les touchez.



Attention – Tensions dangereuses. Pour réduire les risques de décharge électrique et de danger physique, observez les consignes indiquées.

Selon le type d'interrupteur marche/arrêt dont votre appareil est équipé, l'un des symboles suivants sera utilisé:



Marche – Met le système sous tension alternative.



Arrêt – Met le système hors tension alternative.



Veilleuse – L'interrupteur Marche/Veille est sur la position de veille.

Modification du matériel

N'apportez aucune modification mécanique ou électrique au matériel. Sun Microsystems décline toute responsabilité quant à la non-conformité éventuelle d'un produit Sun modifié.

Positionnement d'un produit Sun



Attention – Evitez d'obstruer ou de recouvrir les orifices de votre produit Sun. N'installez jamais un produit Sun près d'un radiateur ou d'une source de chaleur. Si vous ne respectez pas ces consignes, votre produit Sun risque de surchauffer et son fonctionnement en sera altéré.

Niveau de pression acoustique

Le niveau de pression acoustique du lieu de travail définie par la norme DIN 45 635 Part 1000 doit être au maximum de 70 db(A).

Conformité SELV

Le niveau de sécurité des connexions E/S est conforme aux normes SELV.

Connexion du cordon d'alimentation



Attention – Les produits Sun sont conçus pour fonctionner avec des systèmes d'alimentation équipés d'un conducteur neutre relié à la terre (conducteur neutre pour produits alimentés en CC). Pour réduire les risques de décharge électrique, ne branchez jamais les produits Sun sur une source d'alimentation d'un autre type. Contactez le gérant de votre bâtiment ou un électricien agréé si vous avez le moindre doute quant au type d'alimentation fourni dans votre bâtiment.



Attention – Tous les cordons d'alimentation ne présentent pas les mêmes caractéristiques électriques. Les cordons d'alimentation à usage domestique ne sont pas protégés contre les surtensions et ne sont pas conçus pour être utilisés avec des ordinateurs. N'utilisez jamais de cordon d'alimentation à usage domestique avec les produits Sun.

L'avertissement suivant s'applique uniquement aux systèmes équipés d'un interrupteur Veille:



Attention – L'interrupteur d'alimentation de ce produit fonctionne uniquement comme un dispositif de mise en veille. Le cordon d'alimentation constitue le moyen principal de déconnexion de l'alimentation pour le système. Assurez-vous de le brancher dans une prise d'alimentation mise à la terre près du système et facile d'accès. Ne le branchez pas lorsque l'alimentation électrique ne se trouve pas dans le châssis du système.

L'avertissement suivant s'applique uniquement aux systèmes équipés de plusieurs cordons d'alimentation:



Attention – Pour mettre un système équipé de plusieurs cordons d'alimentation hors tension, il est nécessaire de débrancher tous les cordons d'alimentation.

Mise en garde relative aux batteries



Attention – Les batteries risquent d'exploser en cas de manipulation maladroite ou de remplacement incorrect. Pour les systèmes dont les batteries sont remplaçables, effectuez les remplacements uniquement selon le modèle du fabricant ou un modèle équivalent recommandé par le fabricant, conformément aux instructions fournies dans le manuel de service du système. N'essayez en aucun cas de démonter les batteries, ni de les recharger hors du système. Ne les jetez pas au feu. Mettez-les au rebut selon les instructions du fabricant et conformément à la législation locale en vigueur. Notez que sur les cartes processeur

de Sun, une batterie au lithium a été moulée dans l'horloge temps réel. Les batteries ne sont pas des pièces remplaçables par le client.

Couvercle de l'unité

Pour ajouter des cartes, de la mémoire ou des périphériques de stockage internes, vous devez retirer le couvercle de votre système Sun. Remettez le couvercle supérieur en place avant de mettre votre système sous tension.



Attention – Ne mettez jamais des produits Sun sous tension si leur couvercle supérieur n'est pas mis en place. Si vous ne prenez pas ces précautions, vous risquez de vous blesser ou d'endommager le système.

Mise en garde relative au système en rack

La mise en garde suivante s'applique aux racks et aux systèmes montés en rack.



Attention – Pour des raisons de sécurité, le matériel doit toujours être chargé du bas vers le haut. En d'autres termes, vous devez installer, en premier, le matériel qui doit se trouver dans la partie la plus inférieure du rack, puis installer le matériel sur le niveau suivant, etc.



Attention – Afin d'éviter que le rack ne penche pendant l'installation du matériel, tirez la barre anti-basculement du rack.



Attention – Pour éviter des températures de fonctionnement extrêmes dans le rack, assurez-vous que la température maximale ne dépasse pas la fourchette de températures ambiantes du produit déterminée par le fabricant.



Attention – Afin d'empêcher des températures de fonctionnement extrêmes provoquées par une aération insuffisante, assurez-vous de fournir une aération appropriée pour un fonctionnement du matériel en toute sécurité

Avis de conformité des appareils laser

Les produits Sun qui font appel aux technologies lasers sont conformes aux normes de la classe 1 en la matière.

Class 1 Laser Product
Luokan 1 Laserlaite
Klasse 1 Laser Apparat
Laser Klasse 1

Périphériques CD et DVD

L'avertissement suivant s'applique aux périphériques CD, DVD et autres périphériques optiques:



Attention – L'utilisation de contrôles et de réglages ou l'application de procédures autres que ceux spécifiés dans le présent document peuvent entraîner une exposition à des radiations dangereuses.

Einhaltung sicherheitsbehördlicher Vorschriften

Lesen Sie vor dem Ausführen von Arbeiten diesen Abschnitt. Im folgenden Text werden Sicherheitsvorkehrungen beschrieben, die Sie bei der Installation eines Sun Microsystems-Produkts beachten müssen.

Sicherheitsvorkehrungen

Treffen Sie zu Ihrem eigenen Schutz bei der Installation des Geräts die folgenden Sicherheitsvorkehrungen:

- Beachten Sie alle auf den Geräten angebrachten Warnhinweise und Anweisungen.

- Stellen Sie sicher, dass Spannung und Frequenz der Stromversorgung den Nennleistungen auf dem am Gerät angebrachten Etikett entsprechen.
- Führen Sie niemals Fremdoobjekte in die Öffnungen am Gerät ein. Es können gefährliche Spannungen anliegen. Leitfähige Fremdoobjekte können einen Kurzschluss verursachen, der einen Brand, Stromschlag oder Geräteschaden herbeiführen kann.

Symbole

Die Symbole in diesem Handbuch haben folgende Bedeutung:



Achtung – Gefahr von Verletzung und Geräteschaden. Befolgen Sie die Anweisungen.



Achtung – Heiße Oberfläche. Nicht berühren, da Verletzungsgefahr durch heiße Oberfläche besteht.



Achtung – Gefährliche Spannungen. Befolgen Sie die Anweisungen, um Stromschläge und Verletzungen zu vermeiden.

Je nach Netzschaltertyp an Ihrem Gerät kann eines der folgenden Symbole verwendet werden:



Ein – Versorgt das System mit Wechselstrom.



Aus – Unterbricht die Wechselstromzufuhr zum Gerät.



Wartezustand – Der Ein-/Standby-Netzschalter befindet sich in der Standby-Position.

Modifikationen des Geräts

Nehmen Sie keine elektrischen oder mechanischen Gerätemodifikationen vor. Sun Microsystems ist für die Einhaltung der Sicherheitsvorschriften von modifizierten Sun-Produkten nicht haftbar.

Aufstellung von Sun-Geräten



Achtung – Geräteöffnungen Ihres Sun-Produkts dürfen nicht blockiert oder abgedeckt werden. Sun-Geräte sollten niemals in der Nähe von Heizkörpern oder Heißluftklappen aufgestellt werden. Die Nichtbeachtung dieser Richtlinien kann Überhitzung verursachen und die Zuverlässigkeit Ihres Sun-Geräts beeinträchtigen.

Lautstärke

Gemäß den in DIN 45 635 Teil 1000 definierten Vorschriften beträgt die arbeitsplatzbedingte Lautstärke dieses Produkts weniger als 70 dB(A).

SELV-Konformität

Der Sicherheitsstatus der E/A-Verbindungen entspricht den SELV-Anforderungen.

Anschluss des Netzkabels



Achtung – Sun-Geräte sind für Stromversorgungssysteme mit einem geerdeten neutralen Leiter (geerdeter Rückleiter bei gleichstrombetriebenen Geräten) ausgelegt. Um die Gefahr von Stromschlägen zu vermeiden, schließen Sie das Gerät niemals an andere Stromversorgungssysteme an. Wenden Sie sich an den zuständigen Gebäudeverwalter oder an einen qualifizierten Elektriker, wenn Sie nicht sicher wissen, an welche Art von Stromversorgungssystem Ihr Gebäude angeschlossen ist.



Achtung – Nicht alle Netzkabel verfügen über die gleichen Nennwerte. Herkömmliche, im Haushalt verwendete Verlängerungskabel besitzen keinen Überlastschutz und sind daher für Computersysteme nicht geeignet. Verwenden Sie bei Ihrem Sun-Produkt keine Haushalts-Verlängerungskabel.

Die folgende Warnung gilt nur für Geräte mit Standby-Netzschalter:



Achtung – Beim Netzschalter dieses Geräts handelt es sich nur um einen Ein/Standby-Schalter. Zum völligen Abtrennen des Systems von der Stromversorgung dient hauptsächlich das Netzkabel. Stellen Sie sicher, dass das Netzkabel an eine frei zugängliche geerdete Steckdose in der Nähe des Systems angeschlossen ist. Schließen Sie das Stromkabel nicht an, wenn die Stromversorgung vom Systemchassis entfernt wurde.

Die folgende Warnung gilt nur für Geräte mit mehreren Netzkabeln:



Achtung – Bei Produkten mit mehreren Netzkabeln müssen alle Netzkabel abgetrennt werden, um das System völlig von der Stromversorgung zu trennen.

Warnung bezüglich Batterien



Achtung – Bei unsachgemäßer Handhabung oder nicht fachgerechtem Austausch der Batterien besteht Explosionsgefahr. Verwenden Sie bei Systemen mit austauschbaren Batterien ausschließlich Ersatzbatterien desselben Typs und Herstellers bzw. einen entsprechenden, vom Hersteller gemäß den Anweisungen im Service-Handbuch des Produkts empfohlenen Batterietyp. Versuchen Sie nicht, die Batterien auszubauen oder außerhalb des Systems wiederaufzuladen. Werfen Sie die Batterien nicht ins Feuer. Entsorgen Sie die Batterien entsprechend den Anweisungen des Herstellers und den vor Ort geltenden Vorschriften. CPU-Karten von Sun verfügen über eine Echtzeituhr mit integrierter Lithiumbatterie. Diese Batterie darf nur von einem qualifizierten Servicetechniker ausgetauscht werden.

Gehäuseabdeckung

Sie müssen die Abdeckung Ihres Sun-Computersystems entfernen, um Karten, Speicher oder interne Speichergeräte hinzuzufügen. Bringen Sie vor dem Einschalten des Systems die Gehäuseabdeckung wieder an.



Achtung – Nehmen Sie Sun-Geräte nicht ohne Abdeckung in Betrieb. Die Nichtbeachtung dieses Warnhinweises kann Verletzungen oder Geräteschaden zur Folge haben.

Warnungen bezüglich in Racks eingebauter Systeme

Die folgenden Warnungen gelten für Racks und in Racks eingebaute Systeme:



Achtung – Aus Sicherheitsgründen sollten sämtliche Geräte von unten nach oben in Racks eingebaut werden. Installieren Sie also zuerst die Geräte, die an der untersten Position im Rack eingebaut werden, gefolgt von den Systemen, die an nächsthöherer Stelle eingebaut werden, usw.



Achtung – Verwenden Sie beim Einbau den Kippschutz am Rack, um ein Umkippen zu vermeiden.



Achtung – Um extreme Betriebstemperaturen im Rack zu vermeiden, stellen Sie sicher, dass die Maximaltemperatur die Nennleistung der Umgebungstemperatur für das Produkt nicht überschreitet



Achtung – Um extreme Betriebstemperaturen durch verringerte Luftzirkulation zu vermeiden, sollte die für den sicheren Betrieb des Geräts erforderliche Luftzirkulation eingesetzt werden.

Hinweis zur Laser-Konformität

Sun-Produkte, die die Laser-Technologie verwenden, entsprechen den Laser-Anforderungen der Klasse 1.

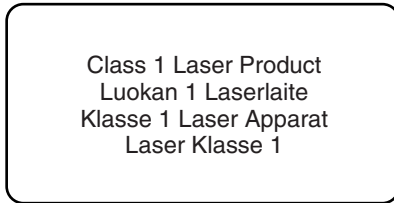

CD- und DVD-Geräte

Die folgende Warnung gilt für CD-, DVD- und andere optische Geräte:



Achtung – Die hier nicht aufgeführte Verwendung von Steuerelementen, Anpassungen oder Ausführung von Vorgängen kann eine gefährliche Strahlenbelastung verursachen.

Normativas de seguridad

Lea esta sección antes de realizar cualquier operación. En ella se explican las medidas de seguridad que debe tomar al instalar un producto de Sun Microsystems.

Medidas de seguridad

Para su protección, tome las medidas de seguridad siguientes durante la instalación del equipo:

- Siga todos los avisos e instrucciones indicados en el equipo.
- Asegúrese de que el voltaje y frecuencia de la fuente de alimentación coincidan con el voltaje y frecuencia indicados en la etiqueta de clasificación eléctrica del equipo.
- No introduzca objetos de ningún tipo por las rejillas del equipo, ya que puede quedar expuesto a voltajes peligrosos. Los objetos conductores extraños pueden producir cortocircuitos y, en consecuencia, incendios, descargas eléctricas o daños en el equipo.

Símbolos

En este documento aparecen los siguientes símbolos:



Precaución – Existe el riesgo de que se produzcan lesiones personales y daños en el equipo. Siga las instrucciones.



Precaución – Superficie caliente. Evite todo contacto. Las superficies están calientes y pueden causar lesiones personales si se tocan.



Precaución – Voltaje peligroso. Para reducir el riesgo de descargas eléctricas y lesiones personales, siga las instrucciones.

En función del tipo de interruptor de alimentación del que disponga el dispositivo, se utilizará uno de los símbolos siguientes:



Encendido – Suministra alimentación de CA al sistema.



Apagado – Corta la alimentación de CA del sistema.



Espera – El interruptor de encendido/espera está en la posición de espera.

Modificaciones en el equipo

No realice modificaciones de tipo mecánico ni eléctrico en el equipo. Sun Microsystems no se hace responsable del cumplimiento de normativas en caso de que un producto Sun se haya modificado.

Colocación de un producto Sun



Precaución – No obstruya ni tape las rejillas del producto Sun. Nunca coloque un producto Sun cerca de radiadores ni fuentes de calor. Si no sigue estas indicaciones, el producto Sun podría sobrecalentarse y la fiabilidad de su funcionamiento se vería afectada.

Nivel de ruido

De conformidad con los requisitos establecidos en el apartado 1000 de la norma DIN 45635, el nivel de ruido en el lugar de trabajo producido por este producto es menor de 70 db(A).

Cumplimiento de la normativa para instalaciones SELV

Las condiciones de seguridad de las conexiones de entrada y salida cumplen los requisitos para instalaciones SELV (del inglés *Safe Extra Low Voltage*, voltaje bajo y seguro).

Conexión del cable de alimentación



Precaución – Los productos Sun se han diseñado para funcionar con sistemas de alimentación que cuenten con un conductor neutro a tierra (con conexión a tierra de regreso para los productos con alimentación de CC). Para reducir el riesgo de descargas eléctricas, no conecte ningún producto Sun a otro tipo de sistema de alimentación. Póngase en contacto con el encargado de las instalaciones de su empresa o con un electricista cualificado en caso de que no esté seguro del tipo de alimentación del que se dispone en el edificio.



Precaución – No todos los cables de alimentación tienen la misma clasificación eléctrica. Los alargadores de uso doméstico no cuentan con protección frente a sobrecargas y no están diseñados para su utilización con sistemas informáticos. No utilice alargadores de uso doméstico con el producto Sun.

La siguiente medida solamente se aplica a aquellos dispositivos que dispongan de un interruptor de alimentación de espera:



Precaución – El interruptor de alimentación de este producto funciona solamente como un dispositivo de espera. El cable de alimentación hace las veces de dispositivo de desconexión principal del sistema. Asegúrese de que conecta el cable de alimentación a una toma de tierra situada cerca del sistema y de fácil acceso. No conecte el cable de alimentación si la unidad de alimentación no se encuentra en el bastidor del sistema.

La siguiente medida solamente se aplica a aquellos dispositivos que dispongan de varios cables de alimentación:



Precaución – En los productos que cuentan con varios cables de alimentación, debe desconectar todos los cables de alimentación para cortar por completo la alimentación eléctrica del sistema.

Advertencia sobre las baterías



Precaución – Si las baterías no se manipulan o reemplazan correctamente, se corre el riesgo de que estallen. En los sistemas que cuentan con baterías reemplazables, reemplácelas sólo con baterías del mismo fabricante y el mismo tipo, o un tipo equivalente recomendado por el fabricante, de acuerdo con las instrucciones descritas en el manual de servicio del producto. No desmonte las baterías ni intente recargarlas fuera del sistema. No intente deshacerse de las baterías echándolas al fuego. Deshágase de las baterías correctamente de acuerdo con las instrucciones del fabricante y las normas locales. Tenga en cuenta que en las placas CPU de Sun, hay una batería de litio incorporada en el reloj en tiempo real. Los usuarios no deben reemplazar este tipo de baterías.

Cubierta de la unidad del sistema

Debe extraer la cubierta de la unidad del sistema informático Sun para instalar tarjetas, memoria o dispositivos de almacenamiento internos. Vuelva a colocar la cubierta antes de encender el sistema informático.



Precaución – No ponga en funcionamiento los productos Sun que no tengan colocada la cubierta. De lo contrario, puede sufrir lesiones personales y ocasionar daños en el sistema.

Advertencia sobre el sistema en bastidor

Las advertencias siguientes se aplican a los sistemas montados en bastidor y a los propios bastidores.



Precaución – Por seguridad, siempre deben montarse los equipos de abajo arriba. A saber, primero debe instalarse el equipo que se situará en el bastidor inferior; a continuación, el que se situará en el siguiente nivel, etc.



Precaución – Para evitar que el bastidor se vuelque durante la instalación del equipo, debe extenderse la barra antivolcado del bastidor.



Precaución – Para evitar que se alcance una temperatura de funcionamiento extrema en el bastidor, asegúrese de que la temperatura máxima no sea superior a la temperatura ambiente establecida como adecuada para el producto.



Precaución – Para evitar que se alcance una temperatura de funcionamiento extrema debido a una circulación de aire reducida, debe considerarse la magnitud de la circulación de aire requerida para que el equipo funcione de forma segura.

Aviso de cumplimiento de la normativa para la utilización de láser

Los productos Sun que utilizan tecnología láser cumplen los requisitos establecidos para los productos láser de clase 1.

Class 1 Laser Product
Luokan 1 Laserlaite
Klasse 1 Laser Apparat
Laser Klasse 1

Dispositivos de CD y DVD

La siguiente medida se aplica a los dispositivos de CD y DVD, así como a otros dispositivos ópticos:



Precaución – La utilización de controles, ajustes o procedimientos distintos a los aquí especificados puede dar lugar a niveles de radiación peligrosos.

Nordic Lithium Battery Cautions

Norge



Advarsel – Litiumbatteri — Eksplosjonsfare. Ved utskifting benyttes kun batteri som anbefalt av apparatfabrikanten. Brukt batteri returneres apparatleverandøren.

Sverige



Varning – Explosionsfara vid felaktigt batteribyte. Använd samma batterityp eller en ekvivalent typ som rekommenderas av apparattillverkaren. Kassera använt batteri enligt fabrikantens instruktion.

Danmark



Advarsel! – Litiumbatteri — Eksplosionsfare ved fejlagtig håndtering. Udskiftning må kun ske med batteri af samme fabrikat og type. Levér det brugte batteri tilbage til leverandøren.

Suomi



Varoitus – Paristo voi räjähtää, jos se on virheellisesti asennettu. Vaihda paristo ainoastaan laitevalmistajan suosittelemaan tyyppiin. Hävitä käytetty paristo valmistajan ohjeiden mukaisesti.

Preface

The *Sun Fire E25K/E20K Systems Hardware Installation and De-Installation Guide* provides procedures for installing and configuring the host hardware and software.

This document is for service personnel and customer data center staff who are involved in the site preparation for and installation of the Sun Fire™ E25K/E20K systems.

How This Book Is Organized

Chapter 1 details safety information and site preparation.

Chapter 2 describes the steps required for system hardware installation and testing.

Chapter 3 shows the steps required for software installation.

Chapter 4 defines the proper procedures for system shutdown and packaging prior to relocating.

Using UNIX Commands

This document might not contain information on basic UNIX® commands and procedures such as shutting down the system, booting the system, and configuring devices. Refer to the following for this information:

- Software documentation that you received with your system
- Solaris™ Operating System documentation, which is at

<http://docs.sun.com>

Shell Prompts

Shell	Prompt
C shell	<i>machine-name%</i>
C shell superuser	<i>machine-name#</i>
Bourne shell and Korn shell	\$
Bourne shell and Korn shell superuser	#

Typographic Conventions

Typeface ¹	Meaning	Examples
AaBbCc123	The names of commands, files, and directories; on-screen computer output	Edit your <code>.login</code> file. Use <code>ls -a</code> to list all files. <code>% You have mail.</code>
AaBbCc123	What you type, when contrasted with on-screen computer output	<code>% su</code> Password:
<i>AaBbCc123</i>	Book titles, new words or terms, words to be emphasized. Replace command-line variables with real names or values.	Read Chapter 6 in the <i>User's Guide</i> . These are called <i>class</i> options. You <i>must</i> be superuser to do this. To delete a file, type <code>rm filename</code> .

¹ The settings on your browser might differ from these settings.

Related Documentation

TABLE P-1 Related Documentation

Application	Title
Site Planning	<i>Sun Fire E25K/E20K Systems Site Planning Guide</i>
Site Planning	<i>Sun Fire E25K/E20K Systems Overview</i>
Installation	<i>Sun Fire E25K/E20K Systems Read Me First</i>
Installation	<i>Sun Fire E25K/E20K Systems Getting Started</i>
Installation	<i>Sun Fire E25K/E20K Systems Unpacking Guide</i>
Service	<i>Sun Fire E25K/E20K Systems Service Manual</i>
Service	<i>Sun Fire E25K/E20K Systems Service Reference I—Nomenclature</i>
Service	<i>Sun Fire E25K/E20K Systems Service Reference II—Component Numbering</i>

Accessing Sun Documentation

You can view, print, or purchase a broad selection of Sun documentation, including localized versions, at:

<http://www.sun.com/documentation>

Contacting Sun Technical Support

If you have technical questions about this product that are not answered in this document, go to:

<http://www.sun.com/service/contacting>

Sun Welcomes Your Comments

Sun is interested in improving its documentation and welcomes your comments and suggestions. You can submit your comments by going to:

<http://www.sun.com/hwdocs/feedback>

Please include the title and part number of your document with your feedback:

Sun Fire E25K/E20K Systems Hardware Installation and De-Installation Guide, part number 817-4135-11

United States Export Control Laws Notice

Products covered by and information contained in this installation and de-installation guide are controlled by U.S. Export Control laws and might be subject to the export or import laws in other countries. Nuclear, missile, chemical biological weapons, or nuclear maritime end uses or end users, whether direct or indirect, are strictly prohibited. Export or re-export to countries subject to U.S. embargo or to entities identified on U.S. export exclusion lists, including but not limited to the denied persons and specially designated nationals lists, is strictly prohibited. Use of any spare or replacement CPUs is limited to repair or one-for-one replacement of CPUs in products exported in compliance with U.S. export laws. Use of CPUs as product upgrades unless authorized by the U.S. Government is strictly prohibited.

Preparing for Sun Fire E25K/E20K Systems Installation

1.1 Safety Precautions

For your protection, observe the following safety precautions when setting up your equipment:

- Follow all cautions, warnings, and instructions marked on the equipment.
- Ensure that the voltage and frequency rating of the power source you use matches the electrical rating label on the equipment.
- Use only properly grounded power outlets.
- Never push objects of any kind through openings in the equipment, because they might touch dangerous voltage points or short out components that can result in fire or electric shock.
- Use only qualified personnel to service the equipment.

To protect both yourself and the equipment, observe the precautions listed in [TABLE 1-1](#).

TABLE 1-1 Safety Precautions

Item	Problem	Precaution
AC/DC power	Electric shock	Verify that all AC and DC power has been properly neutralized prior to servicing. Keep AC ground connected during servicing to provide a cabinet ground for ESD protection.
ESD kit	Static	An approved ESD mat provides protection from static damage when used with a wrist strap or foot strap. Use the Sun Microsystems™-provided ESD kit when handling Sun Fire components.
Wrist strap or foot strap	Static	Wear a conductive wrist strap or foot strap when handling printed circuit boards.
Cover panels	System damage and overheating	Attach all cabinet cover panels after performing any service work on the system.
Filler panels	System damage and overheating	Install card cage filler panels in all unused card cage slots. Open slots severely reduce the cooling capability of the system.
PCI slot covers	System damage and overheating	Install PCI slot covers in all unused system board PCI slots. Openings on the backs of system boards reduce the cooling capability of the system.

Several symbols are used in this guide to mark sections which should receive special attention. Review [TABLE 1-2](#) for these symbols and their definitions.

TABLE 1-2 Symbols







	Caution	This equipment contains lethal voltage. Accidental contact with the centerplane, card cage, and drive areas can result in serious injury or death.
	Caution	Risk of personal injury and equipment damage. To reduce the risk, follow the instructions.
	AC	A terminal to which alternating current or voltage can be applied.

TABLE 1-2 Symbols (Continued)

	Protective earth	Protective earth conductor.
	Chassis	Frame or chassis terminal.
	Fuse replacement marking	For continued protection against risk of fire and electric shock, replace ONLY with the same type and rating of fuse.



Caution – Improper handling by unqualified personnel can cause serious damage to this equipment. Unqualified personnel who tamper with this equipment can be held liable for any resulting damage to the equipment.

All procedures contained in this document must be performed by *qualified service-trained maintenance providers*.



Caution – Before you begin, carefully read each of the procedures in this manual. If you have not performed similar operations on comparable equipment, *do not attempt* to perform these procedures.

1.2 Site Preparation

Note – Site preparation is detailed in the *Sun Fire E25K/E20K Systems Site Planning Guide*.

It is the customer's responsibility to prepare the site. Sun Microsystems Customer Service or an authorized distributor can assist with the site-planning process and will install the equipment upon notification of delivery from the customer.

Prior to the installation of the system, verify the following items:

1. The area for the system has been thoroughly cleaned and vacuumed in preparation for installation.
2. If the customer has noted problems or peculiarities at the site that require special equipment, or if the customer has obtained such equipment.
3. The installation checklist and report have been located and are available.
4. The shipper and Sun Microsystems have been notified of all missing or damaged items.
5. Installation of the necessary electrical equipment is complete, and sufficient power is provided.
6. Adequate air conditioning is provided.
7. The air conditioning system has been operational and running for 48 hours to bring the room to the appropriate temperature.
8. Access to the data center network is available
9. The system is unpacked and moved to the installation area.

The *Sun Fire E25K/E20K Systems Site Planning Guide* and the *Sun Fire E25K/E20K Systems Unpacking Guide* provide the necessary information to complete these tasks.

Installing the Sun Fire E25K/E20K Systems Hardware

This chapter contains information on installing the Sun Fire E25K/E20K systems.

- [Section 2.1, “Tools Required” on page 2-1](#)
- [Section 2.2, “Connecting Power Cables” on page 2-2](#)
- [Section 2.3, “Grounding the Cabinet” on page 2-4](#)
- [Section 2.4, “Connecting the System Controller” on page 2-7](#)
- [Section 2.5, “Connecting the Network Hardware” on page 2-7](#)
- [Section 2.6, “Labeling the I/O Cables” on page 2-8](#)
- [Section 2.7, “Completing the Installation” on page 2-9](#)
- [Section 2.8, “Powering On the System” on page 2-10](#)

Note – Refer to the *Sun Fire E25K/E20K systems Unpacking Guide* for information on unpacking the system and moving it safely off to the operating location.

2.1 Tools Required

- 1/8-inch straight-blade screwdriver
- 3/16-inch straight-blade screwdriver
- No. 2 Phillips screwdriver
- Digital voltmeter (DVM)
- 9/16 inch open-end wrench, or equivalent
- 1/2 inch Nut driver



Caution – Leave the system at its final destination for 24 hours before cabling and powering on the system to prevent problems related to thermal shock and condensation.

2.2 Connecting Power Cables



Caution – Do not make mechanical or electrical modifications to the processor or I/O cabinets. Sun Microsystems is not responsible for regulatory compliance if the cabinets are modified.

The system requires an electrical circuit that is grounded to earth. The American standards group, Underwriters Laboratories, Inc., specifies:

An insulated earth-ground conductor that is identical in size, insulation material, and thickness to the earthed and unearthed branch-circuit supply conductors, except that it is green with or without one or more yellow stripes, is to be installed as part of the branch circuit that supplies the unit or system. The earthing conductor described is to be connected to earth at the service equipment or, if supplied by a separately derived system, at the supply transformer or motor-generator set.

The attachment-plug receptacles in the vicinity of the unit or system are all to be of an earthing type, and the earthing conductors serving these receptacles are to be connected to earth at the service equipment.



Caution – The AC power connections provide a ground path that will protect the components (boards and drives) in the cabinet from static electricity damage.

Complete the following connections with the provided cables:

1. **Verify that *all* of the power supply breakers (AC0, AC1) are in the Off position prior to connecting any power cords.**
2. **Verify with a digital voltmeter (DVM) that the incoming AC voltage is correct for the customer site.**

Refer to the *Sun Fire E25K/E20K Systems Site Planning Guide* for further information.

3. Connect the AC power cords into their appropriate AC connectors on the front panel of the power supply.

See [FIGURE 2-1](#) to determine the proper part number and orientation for connection. The strain relief for the AC0 power cable housing is positioned downward when connected. The strain relief for the AC1 power cable housings is positioned upward when connected. Power source A cord will normally connect into AC0. Power source B cord will normally connect into AC1.

4. Secure all of the cables to improve overall appearance and prevent damage.

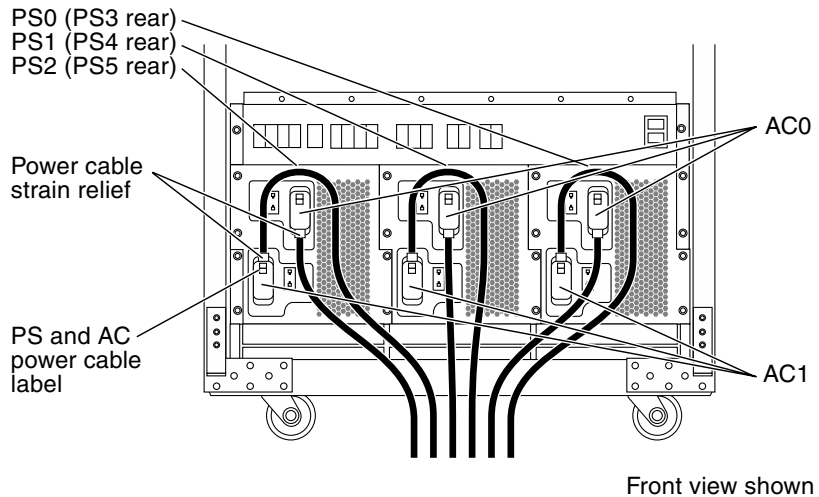

FIGURE 2-1 AC Power Cord Installation

2.3 Grounding the Cabinet

Sun Fire E25K/E20K systems achieve earth ground through the power cords. For this reason, a grounding cable is not provided with the system. The power cords have three prongs: two for current and one for ground. At the AC input module, the ground prong and system chassis are connected. Final chassis ground is achieved when the power cord is connected to a receptacle, where the ground prong contacts the power receptacle.

For successful grounding, the customer must provide properly grounded power receptacles so the power distribution unit (PDU) ground is earth ground. See [FIGURE 2-2](#) for a definition of the grounding system and [FIGURE 2-3](#) for system board power and electrostatic device (ESD) connections.

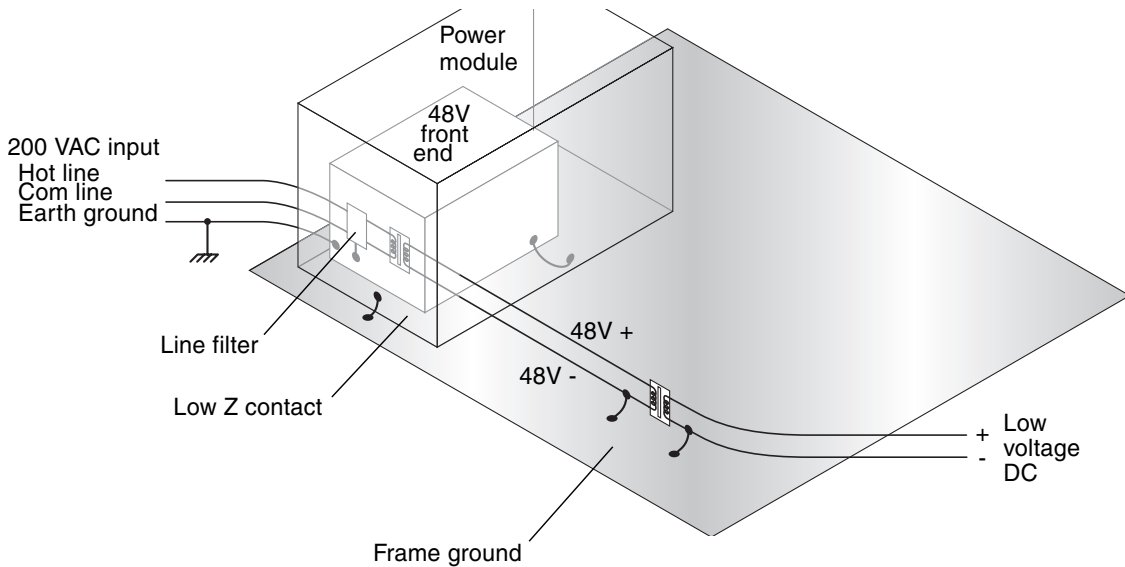

FIGURE 2-2 Sun Fire E25K/E20K Systems Grounding

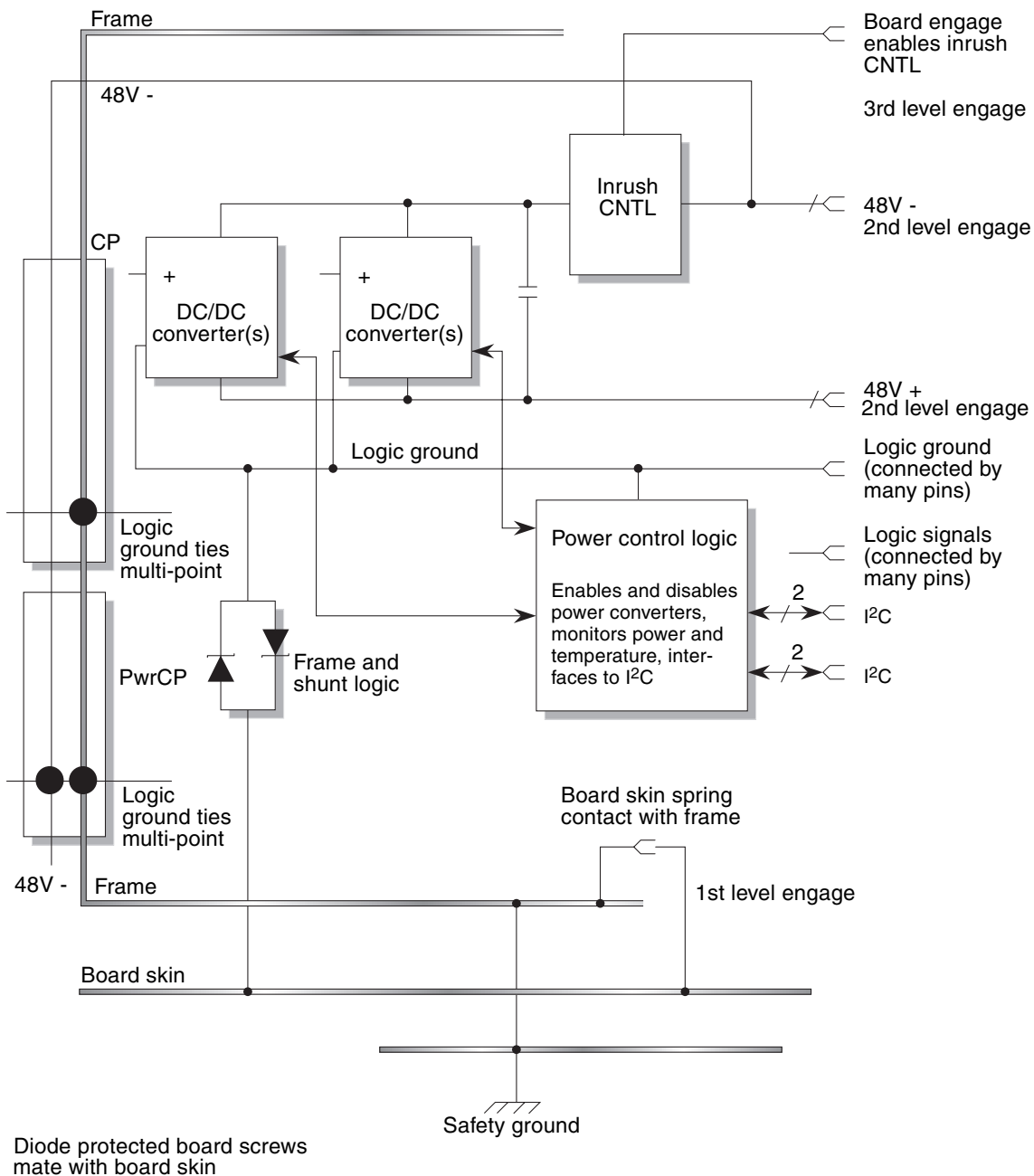

FIGURE 2-3 System Board Power and ESD Connections

A ground cable may be affixed to the system. While not required, the additional ground point allows leakage current to dissipate more efficiently. It is important to note that power cords are grounded through the receptacle and the ground cable must reference a common earth ground. Otherwise, a difference in ground potential can be introduced.



Caution – If the customer is unsure of the facility PDU receptacle grounding, *do not install* a ground cable until a proper PDU receptacle grounding has been confirmed. If a difference in ground potential is apparent, *you must take corrective action*.

Use the following procedures to properly ground the system:

1. Ensure the customer site has properly grounded PDUs in the data center.

The PDU must be earth ground.

2. Ensure that all grounding points (raised floors and power receptacles) reference PDU ground.

Note – A customer who chooses to ground the system must procure the grounding cable. A grounding cable is not shipped with the system.



Caution – During manufacturing, the ground cable attaching area might be a painted surface. Ensure metal-to-metal solid contact is made for this installation.

3. Attach the ground cable to the system, behind the kick plate, at the bottom of the frame base as shown in [FIGURE 2-4](#).

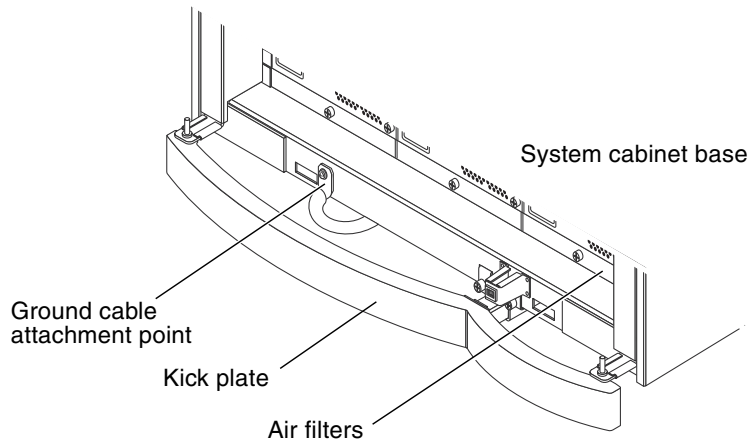

FIGURE 2-4 Ground Cable Attachment Point at System Cabinet

2.4 Connecting the System Controller

The Sun Fire E25K/E20K systems have a system controller (System Control board and system control peripheral) that supports administrative control and monitoring of the platform. Two system controllers are included in each Sun Fire E25K/E20K frame. One system controller acts as the primary controller. A second system controller is available to automatically assume administrative control should the primary system controller fail. System Management Services (SMS) software runs on the system controller and provides the control and monitoring.

The system controllers receive their power from the Sun Fire E25K/E20K power supplies. Connection to the data center power source must be completed in order to power on the system controller and start platform configuration. See [Chapter 2](#) of this document and [Chapter 3](#) of the *Sun Fire E25K/E20K Systems Site Planning Guide* for details about connecting the platform to the data center power source.

Each system controller requires a console connection. This connection is used for initial configuration, including provisions for the IP addresses used on the customer data center network. An eight-pin DIN-type connector on the front of the System Control (SC) processor board can provide the console connection. This cable terminates into a standard DB-25 connector. This cable may be connected to any tip-compatible terminal (such as VT150) or terminal concentrator. Refer to the *Sun Fire E25K/E20K Systems Service Manual* for pin-out termination specifications of the SC-CPU cable.

The console connection, or a Telnet connection, may be used to interact with the command-line versions of the SMS software. A display device is required for GUI administration. Any X-capable device may be used to display the output of the SMS GUI software. Programs will run on the SC with the output displayed on the administrator's terminal.

2.5 Connecting the Network Hardware

The two system controllers and each dynamic system domain require a connection to the customer data center network. These connections must be made prior to configuring the hardware. Review [Chapter 4, Network Planning](#), of the *Sun Fire E25K/E20K Systems Site Planning Guide* for options available in making connections to the data center network.

2.6 Labeling the I/O Cables

Once you have verified the site according to the *Sun Fire E25K/E20K Systems Site Planning Guide* and the system is in place the system cabling can be installed and connected, (FIGURE 2-5). A set of labels is delivered with the system to facilitate labeling new and replaced parts. The set consists of multiple sheets of labels that are used to identify point-to-point connections. The labels can be used for all new cables as well as for relabeling requirements for any cables that might need to be reconfigured.

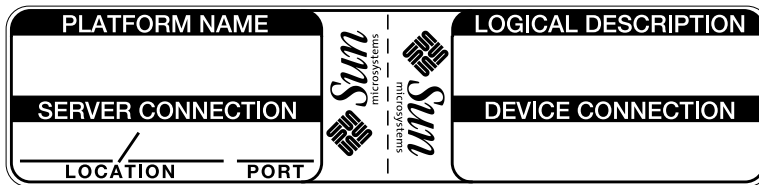

FIGURE 2-5 Cable Label Example

2.7 Completing the Installation

1. Confirm that all cables are firmly seated and the attachment hardware is tight.
2. Position all I/O cables in the I/O cable management guide and secure them with cable ties.

Refer to the *Sun Fire High-End Server Systems Cable Management Guide* for details.

3. Close all of the access doors.
4. Verify that the side panels are positioned correctly on the cabinet.
5. Verify that the leveling feet are properly adjusted and the cabinet is level.

Visually inspect where the two access doors meet. Adjust the leveling feet until the access doors are even and straight. Repeat this step for all four cabinet doors.



Caution – Do not allow the leveling feet to support the entire weight of the system cabinet. Confirm this by visually inspecting the casters to verify that they are in contact with the floor.

2.8 Powering On the System

1. Power on the customer-supplied AC circuit breakers.
2. Ensure that all DC circuit breakers at the front and rear power modules are in the On position (FIGURE 2-6).

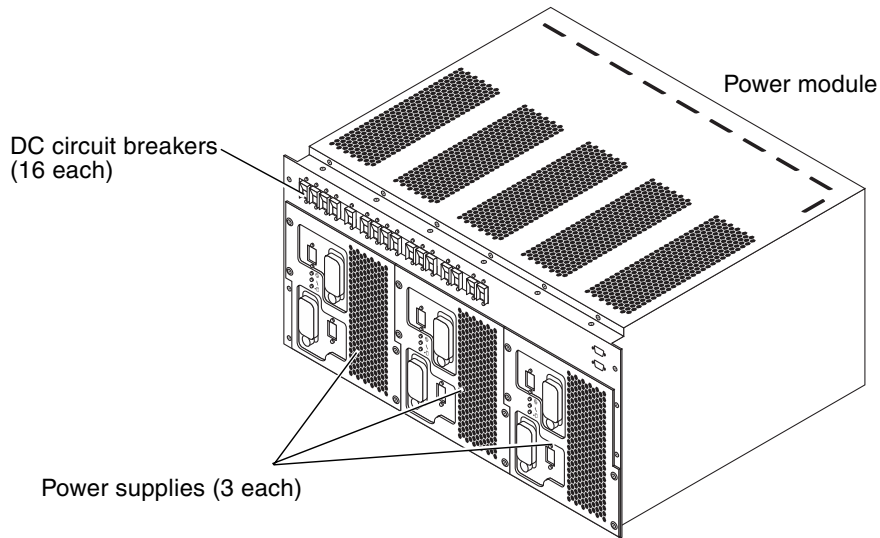

FIGURE 2-6 Circuit Breakers and Power Supplies

3. Apply power to the system.

Sequentially activate all of the front panel circuit breakers (two circuit breakers per power supply, three power supplies per system, front and rear) on the power supply module.

4. Complete the software configuration setup *Parameters Worksheet* and the *Installation Report* that were shipped with the system.

The hardware installation is now complete. In the event of a failure, refer to the following documents:

- *Sun Fire E25K/E20K Systems Overview Manual*
- *Sun Fire E25K/E20K Systems Service Manual*

Installing the Sun Fire E25K/E20K Systems Software

This chapter contains information on installing the Sun Fire E25K/E20K systems software.

- [Section 3.1, “Initial Domain Configuration”](#) on page 3-1
- [Section 3.2, “Running SunVTS on the Host”](#) on page 3-3

3.1 Initial Domain Configuration

The procedures in this chapter are used to install customer network parameters on the first domain of the Sun Fire E25K/E20K systems. These procedures assume that you have opened both an SC command-line window and a `domain console (1M)` window at your terminal display.

This configuration is performed on the preloaded domain when the host arrives at your site from the factory. Do not perform this procedure if you are recovering from a crash or installing a new domain.

1. **Log in to the Main SC as user `sms-svc`.**

The default password is `xxxxxx`.

2. **Create a domain by typing:**

```
sms-svc% addboard -d domain_id domain_tag -c assign
board_type,board_id
```

where *domain_id* = domain letter ID. Valid *domain_ids* are “A”...“R” and case insensitive. *domain_id* ‘A’ should be used for the factory configured domain.

`domain_tag` is a name assigned to a domain using `addtag(1M)`.

where `board_type` = board letter ID. List boards separated by spaces. Board type is optional. `Board_ID` is not optional and corresponds to expander slot pairs. Valid pairs are <0-17>.<0-1>. Multiple board identifier arguments are permitted.

The following `board_type`, `board_id` forms are acceptable:

```
cpu, (0..17) [.0]
iobd, (0..17) [.1] (hsPCI+ I/O)
```

Example:

```
addboard -d A -c assign cpu,0.0 iobd,0.1 cpu,1.0 cpu,2.0
```

3. Bring up the domain by typing:

```
sms-svc% setkeyswitch -d A on
```

4. After the `setkeyswitch` process is complete, type:

```
sms-svc% console -d A
```

After a few minutes, the `ok>` prompt is displayed.

5. Boot the domain by typing:

```
ok> boot
```

When the first time the domain operating system is booted, the administrator is asked to define host-specific information. This includes the hostname, locale, and IP address. See the Solaris installation manuals for this information.

3.2 Running SunVTS on the Host

Once the system has been booted and properly configured on the network, run diagnostics.

The host must first be booted and the local and network variables configured before you run SunVTS™ software.

SunVTS tests the overall functionality of all parts (processor and I/O) of the system. While an overnight SunVTS run is considered ideal, anywhere between 4 and 24 hours is appropriate as a system test.

1. **Log in to an X-capable display station, ensure that your domain can open a connection, and type:**

```
% xhost +
```

2. **Start SunVTS by logging in to the domain as `superuser`, then typing the following commands:**

```
# csh
# setenv DISPLAY sc_hostname:0.0
# setenv LD_LIBRARY_PATH /usr/openwin/lib
# setenv OPENWINHOME /usr/openwin
# /opt/SUNWvts/bin/sunvts -l
```

If SunVTS fails to initialize, you may need to install SunVTS. Refer to the SunVTS AnswerBook™ documentation for more information.

3. **Display the SunVTS window and check the devices shown in the control panel against the devices you know to be physically present in the system.**

Starting SunVTS often serves as a quick check for most hardware devices. If you have just installed a device and reconfigured your system accordingly, the SunVTS test for that device can confirm proper installation.

Refer to the “control panel” section of the SunVTS documentation if there is a discrepancy.

If SunVTS fails to display a device that you know is physically present in the system, recheck your installation carefully.

4. Click the Start button.

If you have enabled the Auto Start option from the Set SunVTS Options menu and saved an options file, you can start SunVTS by typing:

```
# /opt/SUNWvts/bin/sunvts -l -o options_filename
```

5. Monitor the status of SunVTS.

Verify that the system is running and that no test failures are occurring.

6. Repeat [Step 2](#) through [Step 5](#) for each domain to be tested.

De-installing Sun Fire E25K/E20K Systems

This chapter describes the procedures to properly shut down and package the Sun Fire E25K/E20K systems.

- [Section 4.1, “Backing Up Your System” on page 4-1](#)
- [Section 4.2, “Deconfiguring the Domains” on page 4-1](#)
- [Section 4.3, “Preparing to Move the Cabinet” on page 4-3](#)
- [Section 4.4, “Preparing the Cabinet” on page 4-4](#)
- [Section 4.5, “Crating the Cabinet” on page 4-5](#)

4.1 Backing Up Your System

- **Have the system administrator verify that all domains and the SCs have been properly backed up.**

4.2 Deconfiguring the Domains

1. Deconfigure the domains.

Refer to the most recent version of the *Sun Fire E25K/E20K Systems Management Services (SMS) Administrator Guide*.

2. Save the SMS configuration files.

3. Deconfigure the SC.

Refer to the most recent version of the *Sun Fire E25K/E20K Systems Management Services (SMS) Administrator Guide*.

4. Power down the system by referring to the following sections within the *Sun Fire E25K/E20K Systems Service Manual*:

- Section 11.2.2, “Powering Off a Centerplane Support Board” on page 11-4
- Section 6.1.2.2, “Powering Off a System Control (SC) Board” on page 6-4
- Section 7.2.2, “Powering Off a System Control (SC) Peripheral Board” on page 7-5
- Section 12.2.2, “Powering Off an Expander Board” on page 12-4
- Section 8.2.2, “Powering Off a CPU (Slot 0) Board” on page 8-4
- Section 9.1.2.2, “Powering Off an hsPCI+ (Slot 1) Assembly” on page 9-4
- Section 3.2.2.2, “Powering Off a 4 kW Dual AC–DC Power Supply” on page 3-11
- Section 4.2.2, “Powering Off a Fan Tray” on page 4-4
- Section 14.1, “Powering Off for Fan Backplane Removal” on page 14-2
- Section 13.3, “Powering Off the System for Sun Fireplane Interconnect Replacement” on page 13-4
- Section 15.1, “Powering Off the System for Power Centerplane Replacement” on page 15-2
- Section 16.2.1, “Powering Off the System for Cable Replacement” on page 16-8



Note – The *Sun Fire E25K/E20K Systems Service Manual* states that *all* DC circuit breakers are to remain in the On position at all times. *Disregard this statement when deconfiguring the domain in preparation for system relocation.*

- 5. Power off all DC circuit breakers on the front and rear of the system cabinet.**
- 6. Power off all AC0 and AC1 circuit breakers at the front and rear of the system.**
- 7. Power off the customer-supplied AC circuit breakers.**
- 8. Disconnect all power cables from the power supplies at AC0 and AC1 at the front and rear of the system.**

4.3 Preparing to Move the Cabinet

1. Because shipping foam compresses in transit, Sun Fire E25K/E20K systems cabinets cannot be shipped with a previously used shipping pallet. Obtain a new shipping package that contains a new pallet along with some of the following items:

- Pallet-rack fasteners
- Finished packaging (TopCap, outer wraps)
- Closing materials (labeling, bags)

Customers may obtain a shipping package by submitting the *Replacement Packaging Request Form* at <http://206.170.159.131/rplpkg.html>. For Sun service personnel, go to <http://uscq.ebay/Other/packaging.html>.

2. Determine if the customer has strapping material and tools, which are usually available from the customer's shipping department.
3. Obtain the 9/16-inch open-end wrench, or equivalent, is required.

4.4 Preparing the Cabinet

1. **Open the front and rear doors to inspect the cabinet components.**

Confirm that all of the components are fully seated and all of the hardware is tightened.

2. **Inspect the cabinet for any loose hardware or other debris.**
3. **Ensure that all interface cables have been removed from the cabinet.**
4. **Remove the four cabinet doors.**

This prevents damage to the doors when the cabinet is moved.

- a. **Pull down on the top spring-loaded hinge pins.**
- b. **Lift the door upward to remove the door from the pin on the bottom of the cabinet.**
- c. **Set the door aside.**

5. **Install the system handle bars to the front and rear of the system cabinet. Use a No. 2 Phillips screwdriver to secure each handle bar with the four captive screws.**

These two handle bars were removed and retained when the system was installed.

6. **Unbolt the system from the site location floor and remove the NEBS Zone 4 earthquake bushings (if installed).**

7. **Raise the leveling feet and ensure that they are fully retracted into the cabinet frame (FIGURE 4-1).**

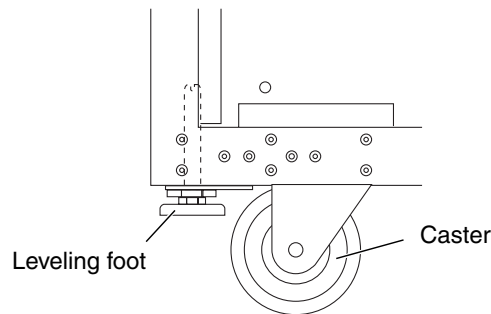

FIGURE 4-1 Retracted Leveling Feet

8. Slowly move the cabinet to the crating location.

One or two persons should push while two others slowly guide the cabinet using the edges of the cabinet frame.



Caution – Do not use the internal system board handles to move the cabinet.

The entire access route to your computer room should be free of raised patterns that can cause vibration and must meet the following clearance requirements:

TABLE 4-1 Access Route Clearance

	With Styling Panel	Without Styling Panel
Minimum door height	80.0 in. (2032 mm)	80.0 in. (2032 mm)
Minimum hallway and door width	36.0 in. (915 mm)	36.0 in. (915 mm)
Maximum incline	10°	10°



Caution – The cabinet cannot be moved at an angle greater than 10 degrees.

4.5 Crating the Cabinet

Note – Access to all sides of the cabinet is needed, with a minimum of 18 feet (5.49 m) to move the cabinet to the pallet ramps.

1. Prepare the pallet deck for the cabinet roll-up.
 - a. Position the shipping pallet on a flat level surface and orient with a minimum of 18 feet (5.49 m) access space for the cabinet and the ramps.
 - b. Remove the ramps from the boxes in the shipping package.
 - c. Align the tines of the ramps with the corresponding holes on the pallet deck.
Verify that the ramps are firmly in position by pressing or standing on the back side of the tines.
 - d. Place one of the two supplied pallet chocks at the non-ramp end of the pallet deck.

2. Remove the front and rear kick plate assemblies (FIGURE 4-2).

This prevents damage to the kick plate mounting bracket assembly during installation.

- a. Use a pull-turn motion to release the spring-loaded captive locking pin, then pull the kick plate and mounting tube outward from the mounting bracket and set aside.
- b. Loosen the two captive panel fasteners of the kick plate mounting bracket assembly.
- c. Remove the kick plate by pulling forward and tipping downward to release the support tabs from their mounting holes.
- d. Set the kick plate assemblies aside.

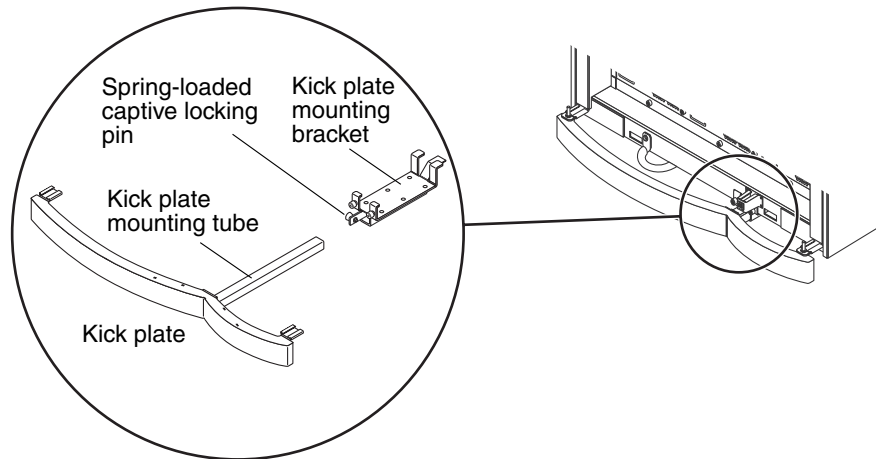

FIGURE 4-2 Cabinet Kick Plate Assembly Removal

3. Align the cabinet wheels at the leading edge of the two ramps (FIGURE 4-3).

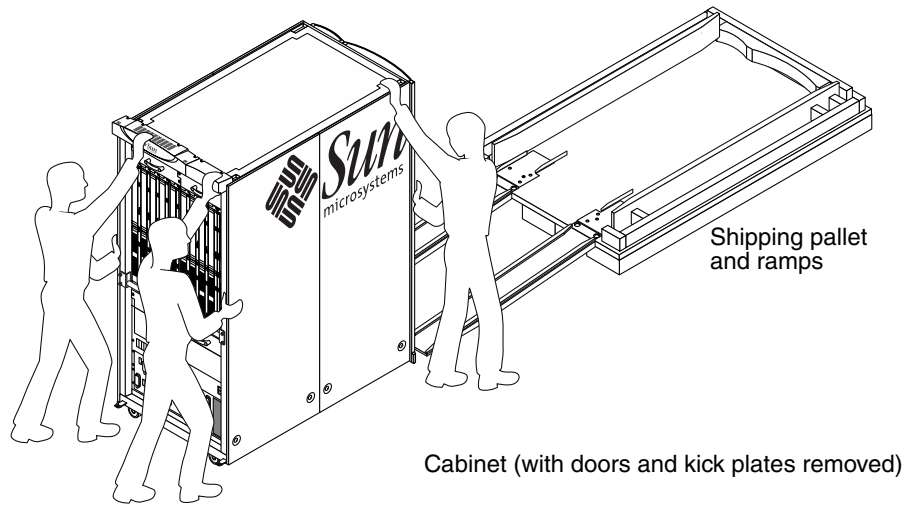

FIGURE 4-3 Installed Ramps on Pallet Deck

Note – The shipping pallet contains holes used to anchor the cabinet onto the pallet deck with zinc-plated shipping brackets and bolts before shipping.

4. Push the cabinet up the ramps and onto the shipping pallet deck.



Caution – One or two persons should push while two others guide the cabinet into the designated shipping position.



Caution – One or two persons should brace the system during [Step 5](#) to ensure that it does not overbalance or slide down the ramps prematurely.

5. Secure the shipping brackets into the ramp side of the system.
 - a. Insert the tow clamp of the shipping bracket into the square hole of the frame at the base of the cabinet.
 - b. Use the 9/16-inch open-end wrench to secure the shipping brackets.
6. Secure the shipping brackets into the non-ramp side of the system.
 - a. Remove the chock on the non-ramp side of the system.

The system remains secured by the shipping brackets at the ramp side of the pallet.
 - b. Insert the tow clamp of the shipping bracket into the square hole of the frame at the base of the cabinet.
 - c. Use the 9/16-inch open-end wrench to secure the shipping brackets.

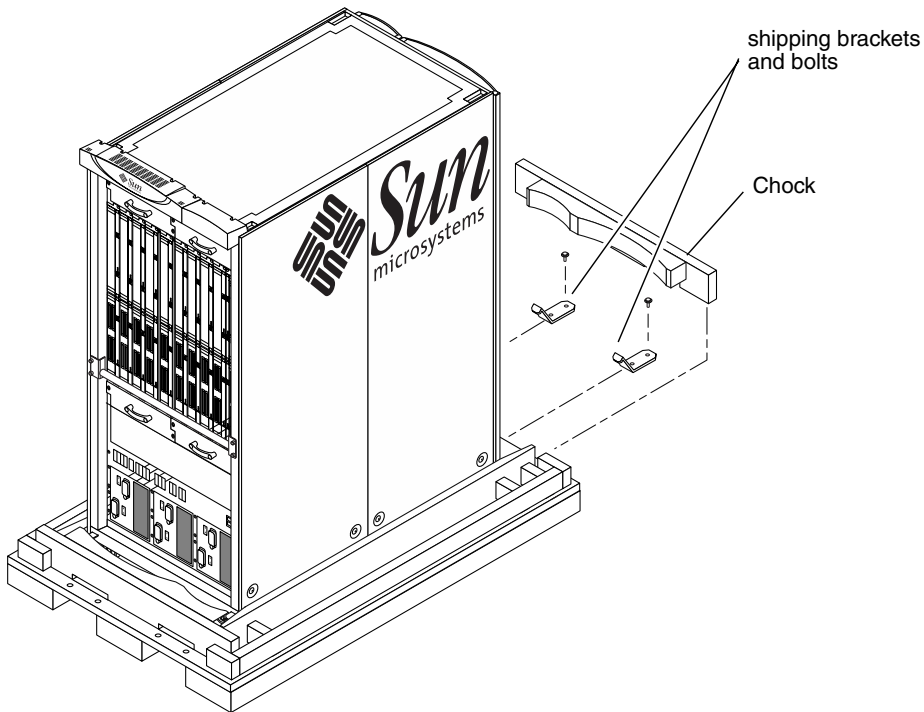

FIGURE 4-4 Cabinet on Shipping Pallet Deck

- 7. Lower each of the four leveling feet to the shipping pallet deck.**

Make an additional 1/4 turn to ensure stability and take some of the weight off the casters of the cabinet.
- 8. Reinstall the kick plate assemblies to the front and rear of the system.**
 - a. Insert the inner support tabs of the kick plate mounting bracket.**
 - b. Align the two outer tabs at the front mounting holes of the cabinet frame.**
 - c. Slide the bracket inward to align the inner support tabs into the two mounting holes of the horizontal support structure under the cabinet.**
 - d. Secure the kick plate with the two captive panel fasteners.**
 - e. Insert the square mounting tube of the kick plate mounting bracket assembly until it is flush with the cabinet.**
 - f. Secure the kick plate with the spring-loaded captive-locking pin.**
- 9. Replace the chocks at the front and rear of the pallet.**
- 10. Restore the four cabinet doors.**
 - a. Insert the door onto the bottom peg for each bottom-hinge bracket of the cabinet.**
 - b. At the top of each door, pull down the spring-loaded pin and insert the peg of the door into the top-hinge bracket of the cabinet.**
 - c. Confirm that the doors can open for servicing.**
- 11. Remove the ramps from the shipping pallet deck and store them at the side(s) of the cabinet.**

4.6 Completing the Packaging

1. Reinspect the cabinet for any loose hardware, tools, or other debris before assembling the remaining packaging materials.
2. Locate the outer protective plastic bag in the shipping package and place over the top and sides of the cabinet. Tuck the bottom edges of the bag into the sides of the shipping pallet.
3. Return the hardware tools to the hardware box of the shipping package and load on the pallet deck at the front or rear of the cabinet.
4. Install the internal carton top cap over the top of the protective plastic bag and cabinet.
5. Attach the service documentation package to the outside of the protective plastic bag.
6. Place the coiled power cables in the shipping kit boxes.

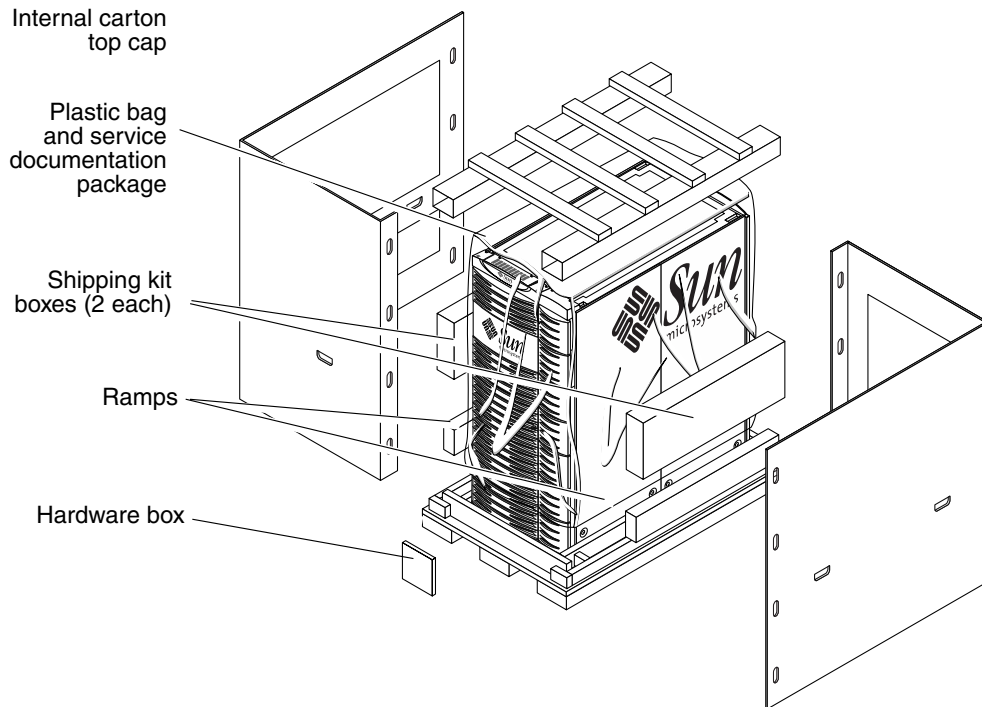

FIGURE 4-5 Final Packaging and Outside Carton Packaging Assemblies

7. Assemble the outside carton (FIGURE 4-5).
 - a. Using the hand cutouts, place each of the two outer carton wraps onto the shipping pallet deck, aligning the holes for the plastic locking clips (four per side).
 - b. Install the eight plastic locking clips (four per side) into the side edges of the outer carton wraps.
 - c. Place the carton top cap on top of the cabinet and over the edges of the outer carton wraps.
 - d. Secure with strapping material and fiberboard edge protectors.

Ensure that the banding material is tight and properly fitted with the edge protectors (FIGURE 4-6).

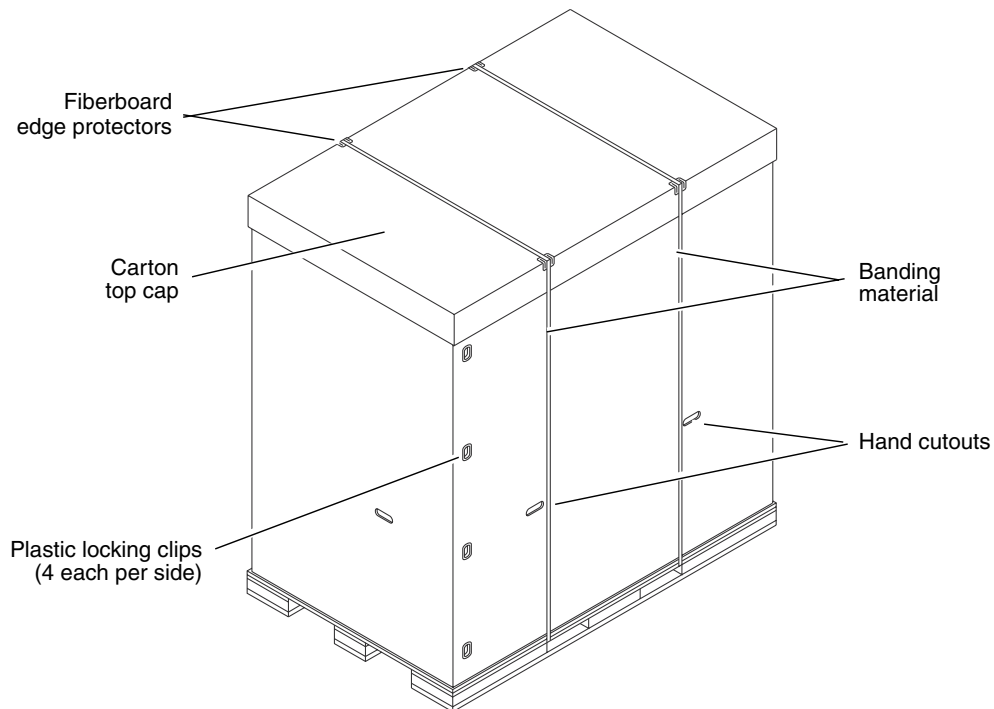

FIGURE 4-6 Cabinet Ready for Shipping

8. Apply the **TIP-N-TELL** device found in the shipping package to the upper half of the carton side.

Note – Use a 60-inch pallet jack to transport the container.

Index

C

- cabinet
 - unpacking, 1-4
- cabling
 - grounding, 2-2
 - power, 2-2
 - signal, 2-8
- circuit breakers, 2-10
- console connection, 2-7
- crating the cabinet, 4-5

D

- DIN-type connector, 2-7
- distribution unit, 2-4

E

- ESD connections, 2-5

G

- ground cable attaching, 2-6
- grounding
 - points, 2-6
 - system, 2-4

I

- installation
 - completing, 2-9
 - power cables, 2-2

L

- leveling feet, 2-9, 4-4, 4-9

M

- moving the cabinet
 - needed items, 4-3
 - preparing the cabinet, 4-4

P

- PDU receptacle grounding, 2-6
- power cabling requirements, 2-2

R

- receptacle grounding, 2-6

S

- safety precautions, 1-1
- signal cabling, 2-8

strapping material, 4-3
system precautions, 1-2

T

tools required, 2-1

U

unpacking, 1-4