

Sun Fire™ E25K/E20K Systems Unpacking Guide

Read Me First

Note – After the Sun Fire™ E25K/E20K systems arrive, contact your local service provider. Installation, verification, and maintenance must be performed only by qualified service personnel.

1. Audit the site to ensure everything is prepared.

If a raised floor is installed at the operating location, locate the cable cutouts. Verify that proper air flow floor panels are used and cable access is available. Refer to the Sun Fire *E25K/E20K Systems Site Planning Guide*.

2. Review the TIP N TELL device and all packaging components to verify that the container was not damaged during shipment.

If damage is evident, note on airbill or bill of lading. Failure to note damage may invalidate future claims. Noting possible damage allows the claimant time to file a claim with the shipping carrier. If you notice any damage, email a damage report to bvtn-traffic@west.sun.com, your contact for shipping or delivery problems.

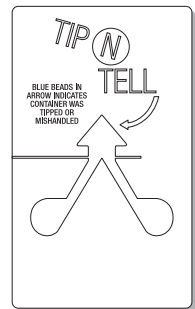

3. If multiple systems were shipped, separate all boxes by the serial numbers listed on the shipping label. Confirm that all boxes are present.

Note – Use a 60-inch pallet jack to transport the container. Access to all sides of the cabinet is needed. A minimum of 18 feet [5.49 meters] of floor space is required to move the cabinet from the pallet, down the ramp, and onto the floor. Note the “RAMPS ATTACH THIS END” markings and images on both ends of the shipping carton. The shipping label on the carton indicates the front of the unit.



Caution – Consider the elevator capacity and its below-threshold drop possibility when carrying a maximum load. The uncrated unit maximum weight is 2,513.7 lbs (1,142.6 kg).

Note – Unpack the shipping carton outside the data center to prevent contaminating the controlled environment.

4. Remove the outer carton.

- a. Cut the outer banding.
- b. Remove the carton top cap.
- c. Squeeze the center flanges together while pulling outward to remove the eight plastic locking clips (four per side).
- d. Remove the outer cartons.

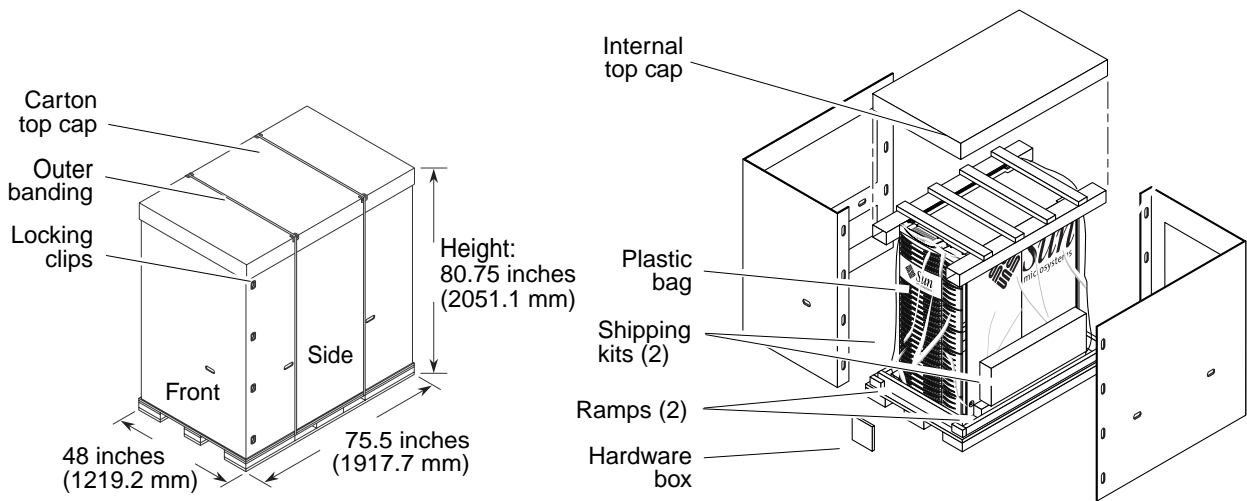

5. Remove the internal top cap.

6. Remove the hardware box and the two shipping kits.

Take the 9/16-inch open-end wrench from the hardware box, and retain the remaining items for later use.

7. Remove the ramps from the sides of the pallet and set them aside for later use.

8. Remove the plastic bag.

9. Remove the four cabinet doors.

This prevents damage to the doors during installation.

- a. Pull down on the top spring-loaded hinge pins.
- b. Lift the door upward to remove the door from the pin on the bottom of the cabinet.
- c. Set the door aside.

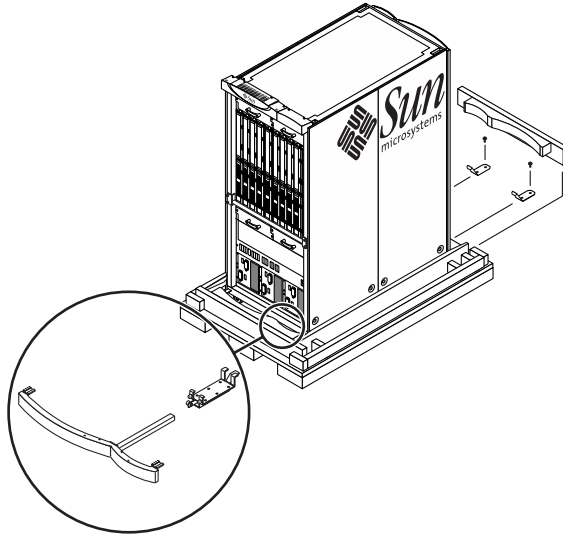

10. Remove the front and rear chocks and set them aside.

The system is secured to the pallet by shipping brackets to prevent rolling. Retain the chocks for later use.

11. Remove the front and rear kick plate assemblies.

This prevents damage to the kick plate mounting bracket assembly during installation.

- a. Use a pull-turn motion to release the spring-loaded captive locking pin.
- b. Pull the kick plate and mounting tube outward from the mounting bracket and set aside.
- c. Loosen the two captive panel fasteners of the kick plate mounting bracket assembly.
- d. Remove the kick plate assembly by pulling forward and tipping downward to release the support tabs from their mounting holes.
- e. Place the kick plate assemblies aside.

12. Align the tines of the ramps with the holes at either the front or rear of the pallet.

Verify the ramps are firmly in position by pressing or standing on the back side of the tines.

13. Use the 9/16-inch open-end wrench to remove the shipping brackets on the non-ramp side of the pallet.

The system remains secured by the shipping brackets at the ramp side of the pallet. Retain the shipping brackets for later use.

14. Return the chock to the non-ramp side of the pallet.

This keeps the system from rolling off the pallet while the remaining shipping brackets are removed.



Caution – One or two persons should brace the system during Step 15 to ensure that it does not overbalance or slide down the ramps prematurely.

15. Use the 9/16-inch open-end wrench to remove the shipping brackets on the ramp side of the pallet.

Retain the shipping brackets for later use.

16. Remove packing materials from in and around the system.
17. Gather up excess parts, cables, and documentation.
18. Raise the leveling feet as high as they will go, so that the system is free to move.



Caution – *Do not* use the internal system board handles to move the cabinet. The cabinet cannot be moved at an angle of more than 10 degrees maximum.

19. Slowly move the cabinet off the pallet and to the site location.

One or two persons should push while two others slowly guide the cabinet down the ramps. Maneuver the cabinet using the edges of the cabinet frame and the handle bars. TABLE 1 provides route clearance information.

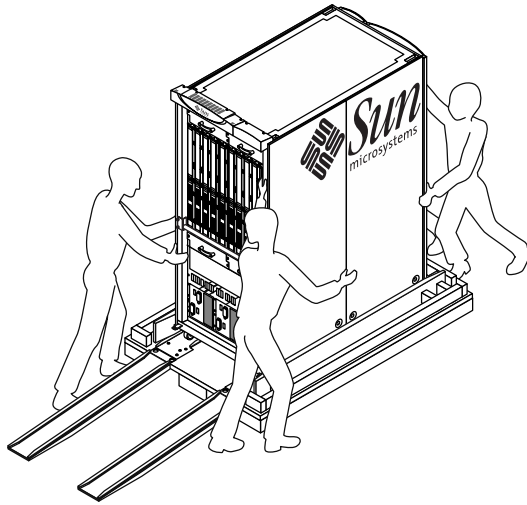

TABLE 1 Access Route Clearance

	With Styling Panel	Without Styling Panel
Minimum door height	80.0 in. (2032 mm)	80.0 in. (2032 mm)
Minimum hallway and door width	36.0 in. (915 mm)	36.0 in. (915 mm)
Maximum incline	10°	10°

20. Fully extend the four leveling feet at the base of each corner of the cabinet.
Make an additional 1/4 turn of the leveling feet to ensure stability.
21. Use a Phillips No. 2 screwdriver to loosen the four captive screws on the front handle bar and the four captive screws on the rear handle bar.
Retain the handle bars for later use.

22. Re-install the kick plate assemblies to the front and rear of the system.

- a. Insert the inner support tabs of the kick plate mounting bracket into the two outer tabs at the front mounting holes of the cabinet frame.
- b. Slide the bracket inward to align the inner support tabs into the two mounting holes of the horizontal support structure under the cabinet.
- c. Secure the bracket with the two captive panel fasteners.
- d. Insert the square mounting tube of the kick plate into the kick plate mounting bracket assembly until it is flush with the cabinet.
- e. Secure the spring-loaded captive-locking pin on the sides of the kick plate.

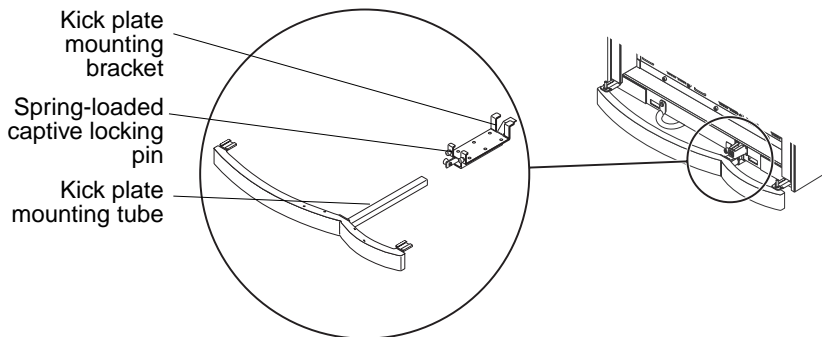

23. Restore the four cabinet doors.

- a. Insert the door onto the bottom peg for each bottom-hinge bracket of the cabinet.
- b. At the top of each door, pull down the spring-loaded pin and insert the peg of the door into the top-hinge bracket of the cabinet.
- c. Confirm the doors can open for servicing.

24. Place the I/O cabinets in the designated area.

Refer to the Sun Fire E25K/E20K *Systems Site Planning Guide* for floor layout samples.

Note – Refer to the Sun Fire E25K/E20K *Systems Hardware Installation and De-Installation Guide* to continue the installation of the Sun Fire E25K/E20K systems.



Caution – Leave the Sun Fire E25K/E20K systems at its final destination for 24 hours before cabling and powering on the system to prevent problems related to thermal shock and condensation.

Note – Shipping materials cannot be reused due to foam compression. Dispose of the material according to the customer's instructions. Reduce and recycle whenever possible.

Accessing Sun Documentation

You can view, print, or purchase a broad selection of Sun documentation, including localized versions, at:

<http://www.sun.com/documentation>

Contacting Sun Technical Support

If you have technical questions about this product that are not answered in this document, go to:

<http://www.sun.com/service/contacting>

Sun Welcomes Your Comments

Sun is interested in improving its documentation and welcomes your comments and suggestions. You can submit your comments by going to:

<http://www.sun.com/hwdocs/feedback>

Please include the title and part number of your document with your feedback:

Sun Fire E25K/E20K Systems Unpacking Guide, part number 817-4134-11

Copyright 2004 Sun Microsystems, Inc. All rights reserved. Use is subject to license terms. Third-party software, including font technology, is copyrighted and licensed from Sun suppliers. Portions may be derived from Berkeley BSD systems, licensed from U. of CA. Sun, Sun Microsystems, the Sun logo, and Solaris are trademarks or registered trademarks of Sun Microsystems, Inc. in the U.S. and in other countries. All SPARC trademarks are used under license and are trademarks or registered trademarks of SPARC International, Inc. in the U.S. and in other countries. U.S. Government Rights—Commercial use. Government users are subject to the Sun Microsystems, Inc. standard license agreement and applicable provisions of the FAR and its supplements.

Copyright 2004 Sun Microsystems, Inc. Tous droits réservés. Distribué par des licences qui en restreignent l'utilisation. Le logiciel détenu par des tiers, et qui comprend la technologie relative aux polices de caractères, est protégé par un copyright et licencié par des fournisseurs de Sun. Des parties de ce produit pourront être dérivées des systèmes Berkeley BSD licenciés par l'Université de Californie. Sun, Sun Microsystems, le logo Sun, et Solaris sont des marques de fabrique ou des marques déposées de Sun Microsystems, Inc. aux Etats-Unis et dans d'autres pays. Toutes les marques SPARC sont utilisées sous licence et sont des marques de fabrique ou des marques déposées de SPARC International, Inc. aux Etats-Unis et dans d'autres pays.



Sun Microsystems, Inc.
www.sun.com