



Sun Fire™ E2900 System Service Manual

Sun Microsystems, Inc.
www.sun.com

Part No. 817-4054-11
September 2004, Revision A

Submit comments about this document at: <http://www.sun.com/hwdocs/feedback>

Copyright 2004 Sun Microsystems, Inc., 4150 Network Circle, Santa Clara, California 95054, U.S.A. All rights reserved.

Sun Microsystems, Inc. has intellectual property rights relating to technology that is described in this document. In particular, and without limitation, these intellectual property rights may include one or more of the U.S. patents listed at <http://www.sun.com/patents> and one or more additional patents or pending patent applications in the U.S. and in other countries.

This document and the product to which it pertains are distributed under licenses restricting their use, copying, distribution, and decompilation. No part of the product or of this document may be reproduced in any form by any means without prior written authorization of Sun and its licensors, if any.

Third-party software, including font technology, is copyrighted and licensed from Sun suppliers.

Parts of the product may be derived from Berkeley BSD systems, licensed from the University of California. UNIX is a registered trademark in the U.S. and in other countries, exclusively licensed through X/Open Company, Ltd.

Sun, Sun Microsystems, the Sun logo, AnswerBook2, docs.sun.com, Sun Fire, SunSolve Online, OpenBoot, SunVTS, and Solaris are trademarks or registered trademarks of Sun Microsystems, Inc. in the U.S. and in other countries.

All SPARC trademarks are used under license and are trademarks or registered trademarks of SPARC International, Inc. in the U.S. and in other countries. Products bearing SPARC trademarks are based upon an architecture developed by Sun Microsystems, Inc. The OPEN LOOK and Sun™ Graphical User Interface was developed by Sun Microsystems, Inc. for its users and licensees. Sun acknowledges the pioneering efforts of Xerox in researching and developing the concept of visual or graphical user interfaces for the computer industry. Sun holds a non-exclusive license from Xerox to the Xerox Graphical User Interface, which license also covers Sun's licensees who implement OPEN LOOK GUIs and otherwise comply with Sun's written license agreements.

U.S. Government Rights—Commercial use. Government users are subject to the Sun Microsystems, Inc. standard license agreement and applicable provisions of the FAR and its supplements.

DOCUMENTATION IS PROVIDED "AS IS" AND ALL EXPRESS OR IMPLIED CONDITIONS, REPRESENTATIONS AND WARRANTIES, INCLUDING ANY IMPLIED WARRANTY OF MERCHANTABILITY, FITNESS FOR A PARTICULAR PURPOSE OR NON-INFRINGEMENT, ARE DISCLAIMED, EXCEPT TO THE EXTENT THAT SUCH DISCLAIMERS ARE HELD TO BE LEGALLY INVALID.

Copyright 2004 Sun Microsystems, Inc., 4150 Network Circle, Santa Clara, California 95054, Etats-Unis. Tous droits réservés.

Sun Microsystems, Inc. a les droits de propriété intellectuelle relatants à la technologie qui est décrit dans ce document. En particulier, et sans la limitation, ces droits de propriété intellectuelle peuvent inclure un ou plus des brevets américains énumérés à <http://www.sun.com/patents> et un ou les brevets plus supplémentaires ou les applications de brevet en attente dans les Etats-Unis et dans les autres pays.

Ce produit ou document est protégé par un copyright et distribué avec des licences qui en restreignent l'utilisation, la copie, la distribution, et la décompilation. Aucune partie de ce produit ou document ne peut être reproduite sous aucune forme, par quelque moyen que ce soit, sans l'autorisation préalable et écrite de Sun et de ses bailleurs de licence, s'il y en a.

Le logiciel détenu par des tiers, et qui comprend la technologie relative aux polices de caractères, est protégé par un copyright et licencié par des fournisseurs de Sun.

Des parties de ce produit pourront être dérivées des systèmes Berkeley BSD licenciés par l'Université de Californie. UNIX est une marque déposée aux Etats-Unis et dans d'autres pays et licenciée exclusivement par X/Open Company, Ltd.

Sun, Sun Microsystems, le logo Sun, AnswerBook2, docs.sun.com, Sun Fire, SunSolve Online, OpenBoot, SunVTS, et Solaris sont des marques de fabrique ou des marques déposées de Sun Microsystems, Inc. aux Etats-Unis et dans d'autres pays.

Toutes les marques SPARC sont utilisées sous licence et sont des marques de fabrique ou des marques déposées de SPARC International, Inc. aux Etats-Unis et dans d'autres pays. Les produits portant les marques SPARC sont basés sur une architecture développée par Sun Microsystems, Inc.

L'interface d'utilisation graphique OPEN LOOK et Sun™ a été développée par Sun Microsystems, Inc. pour ses utilisateurs et licenciés. Sun reconnaît les efforts de pionniers de Xerox pour la recherche et le développement du concept des interfaces d'utilisation visuelle ou graphique pour l'industrie de l'informatique. Sun détient une licence non exclusive de Xerox sur l'interface d'utilisation graphique Xerox, cette licence couvrant également les licenciées de Sun qui mettent en place l'interface d'utilisation graphique OPEN LOOK et qui en outre se conforment aux licences écrites de Sun.

LA DOCUMENTATION EST FOURNIE "EN L'ÉTAT" ET TOUTES AUTRES CONDITIONS, DECLARATIONS ET GARANTIES EXPRESSES OU TACITES SONT FORMELLEMENT EXCLUES, DANS LA MESURE AUTORISEE PAR LA LOI APPLICABLE, Y COMPRIS NOTAMMENT TOUTE GARANTIE IMPLICITE RELATIVE A LA QUALITE MARCHANDE, A L'APTITUDE A UNE UTILISATION PARTICULIERE OU A L'ABSENCE DE CONTREFAÇON.



Adobe PostScript

Sun Proprietary/Confidential: Need-to-Know

Contents

Preface xv

1. Fault Isolation 1-1

1.1 System Identification 1-1

1.2 Basic Troubleshooting 1-5

1.2.1 Power Distribution 1-6

1.2.1.1 Normal Operation 1-6

1.2.1.2 Abnormal Operation 1-6

1.2.2 Main Fans 1-7

1.2.3 System Controller 1-7

1.3 SunVTS Software 1-7

1.4 Other Fault Isolation Aids 1-8

1.4.1 Interpreting LEDs 1-9

1.4.1.1 System Enclosure LEDs 1-10

1.4.1.2 Board or Component LEDs 1-13

1.4.2 Dynamic Reconfiguration (DR) 1-14

1.4.3 Sun Management Center Software and SunSolve OnLine 1-14

1.4.4 OpenBoot Firmware 1-14

1.4.5 Other Utilities 1-15

- 2. Safety, Tools Requirements, and Periodic Maintenance 2-1**
 - 2.1 Safety Precautions 2-2
 - 2.2 Symbols 2-3
 - 2.3 Electrical Safety Precautions 2-4
 - 2.4 System Cabinet Safety Precautions 2-4
 - 2.5 Handling Boards and Assemblies 2-5
 - 2.6 Extending the System Cabinet Stabilizer Bar 2-6
 - 2.7 Filler Boards and Filler Panels 2-6
 - 2.8 Antistatic Precautions 2-6
 - 2.9 Tools Required 2-8
 - 2.10 Removing and Replacing the Front Doors 2-8
 - 2.10.1 Removing the Front Doors 2-8
 - 2.10.2 Replacing the Front Doors 2-9
 - 2.11 Periodic Maintenance 2-10
 - 2.11.1 Replacing or Cleaning the Air Filters 2-10

- 3. System Access and Transportation 3-1**
 - 3.1 Sliding the System Out of the System Cabinet 3-1
 - 3.2 Sliding the System Into the System Cabinet 3-5
 - 3.3 Transporting the System 3-5
 - 3.3.1 Transporting the System Between Cabinets 3-5
 - 3.3.1.1 Securing the System on the Shipping Cradle 3-6
 - 3.3.1.2 Transporting the System 3-11
 - 3.3.2 Transporting the System Cabinet With Installed Systems 3-13
 - 3.3.3 After Transporting the System Cabinet With Systems Installed 3-14

- 4. Powering On and Off 4-1**
 - 4.1 Powering On the System 4-1
 - 4.2 Taking the System to Standby Mode 4-2

4.2.1	Alternate Method to Halt the Solaris OS	4-2
4.3	Using the On/Standby Switch	4-3
4.3.1	Preventing Accidental Operation of the On/Standby Switch	4-4
5.	Cable Management Arm	5-1
5.1	CMA-Lite	5-2
5.1.1	Removing the CMA-Lite	5-2
5.1.2	Installing the CMA-Lite	5-3
5.2	CMA-800	5-3
5.2.1	Removing the CMA-800	5-3
5.2.2	Installing the CMA-800	5-4
6.	Storage Devices	6-1
6.1	Hard Disk Drives	6-1
6.1.1	Removing a Hard Disk Drive	6-2
6.1.2	Installing a Hard Disk Drive	6-4
6.2	Removable Media Module	6-5
6.2.1	Removing the Removable Media Module	6-6
6.2.2	Installing the Removable Media Module	6-10
6.3	Tape Drive	6-10
6.3.1	Replacing an Existing Tape Drive	6-11
6.3.2	Installing a New Tape Drive	6-12
6.4	DVD-ROM Drive	6-14
6.4.1	Replacing the DVD-ROM Drive	6-14
6.5	DVD-ROM Backplane	6-16
6.5.1	Replacing the DVD-ROM Backplane	6-16
6.6	SCC Reader	6-18
6.6.1	Removing the SCC Reader	6-18
6.6.2	Installing the SCC Reader	6-21

7. Cooling Subsystem 7-1

7.1 Main Fans 7-2

7.1.1 Fan Failures 7-2

7.1.2 Removing a Main Fan 7-4

7.1.3 Installing a Main Fan 7-6

7.2 Main Fan Tray 7-7

7.2.1 Removing the Main Fan Tray 7-7

7.2.2 Installing the Main Fan Tray 7-10

7.3 IB Fans 7-11

7.3.1 Removing an IB Fan 7-12

7.3.2 Installing an IB Fan 7-14

8. Power Subsystem 8-1

8.1 Power Supplies 8-2

8.1.1 Removing a Power Supply 8-3

8.1.2 Installing a Power Supply 8-4

8.2 Power Inlet Box 8-4

8.2.1 Removing the Power Inlet Box 8-5

8.2.2 Installing the Power Inlet Box 8-6

8.3 Power Distribution Board 8-6

8.3.1 Removing the Power Distribution Board 8-6

8.3.2 Installing the Power Distribution Board 8-8

9. CPU/Memory Boards 9-1

9.1 Filler Boards 9-2

9.2 CPU/Memory Boards 9-3

9.2.1 Removing a CPU/Memory Board 9-4

9.2.2 Installing a CPU/Memory Board 9-8

9.3 DIMMs 9-11

- 9.3.1 DIMM Bank Configuration Guidelines 9–12
- 9.3.2 Removing DIMMs 9–12
- 9.3.3 Installing DIMMs 9–15

- 10. IB_SSC Assembly 10–1**
 - 10.1 IB_SSC Assembly 10–1
 - 10.1.1 Removing the IB_SSC Assembly 10–2
 - 10.1.2 Installing the IB_SSC Assembly 10–7
 - 10.2 PCI Cards 10–8
 - 10.2.1 Removing a PCI Card 10–9
 - 10.2.2 Installing a PCI Card 10–12

- 11. L2 Repeater Boards 11–1**
 - 11.1 L2 Repeater Board 11–1
 - 11.1.1 Removing an L2 Repeater Board 11–2
 - 11.1.2 Installing the L2 Repeater Board 11–4

- 12. System Indicator Board 12–1**
 - 12.1 System Indicator Board 12–1
 - 12.1.1 Removing the System Indicator Board 12–2
 - 12.1.2 Installing the System Indicator Board 12–4

- 13. Baseplane 13–1**
 - 13.1 Baseplane Overview and Cautions 13–1
 - 13.1.1 Removing the Baseplane 13–2
 - 13.1.2 Installing the Baseplane 13–5

- 14. Antigravity Clutches 14–1**
 - 14.1 Clutch 14–1
 - 14.1.1 Clutch Locations 14–2
 - 14.1.2 Replacing a Clutch 14–5

15. Side Handles 15-1

15.1 Replacing the Handles 15-1

A. Parts List A-1

B. Connectors B-1

B.1 Sun Fire E2900 System Connectors B-1

B.2 Gigabit Ethernet Connectors B-3

B.3 Serial Connectors B-4

B.4 SCSI Connector B-5

B.4.1 SCSI Implementation B-6

B.5 10/100 LOM/System Controller Ethernet Connector B-6

B.5.1 Twisted-Pair Ethernet Cable-Type Connectivity B-7

B.6 Alarms Port B-8

Glossary Glossary-1

Index Index-1

Figures

- FIGURE 1-1 System Top View 1-2
- FIGURE 1-2 System Front View 1-3
- FIGURE 1-3 System Rear View 1-4
- FIGURE 1-4 System Front Panel LEDs 1-10
- FIGURE 1-5 Rear Panel System LEDs 1-12
- FIGURE 2-1 Attaching the Antistatic Wrist Strap—Right Side 2-7
- FIGURE 2-2 Front View of System 2-9
- FIGURE 2-3 Front Door Latches 2-10
- FIGURE 2-4 Location of the Air Filters 2-11
- FIGURE 2-5 Installing the Sun Fire E2900 System Air Filters 2-12
- FIGURE 3-1 Sun Rack 900 System Cabinet With Stabilizer Bar Extended 3-2
- FIGURE 3-2 Sliding the System Out of the System Cabinet 3-3
- FIGURE 3-3 Side Handles Captive Screws 3-4
- FIGURE 3-4 Slide Locking Nut 3-4
- FIGURE 3-5 Shipping Cradle Details 3-6
- FIGURE 3-6 Slide Cutouts 3-7
- FIGURE 3-7 Sliding the System Out of the System Cabinet 3-8
- FIGURE 3-8 Lifting Device and Shipping Cradle 3-9
- FIGURE 3-9 Securing the Captive Screws 3-10
- FIGURE 3-10 Detaching the Cabinet Slides From the System 3-11

- FIGURE 3-11 Retention Washer and Nut 3-13
- FIGURE 3-12 Inserting and Tightening the Retention Washer 3-13
- FIGURE 3-13 Inserting and Tightening the Retention Nut 3-14
- FIGURE 4-1 Sun Fire E2900 System On/Standby Switch 4-3
- FIGURE 5-1 Bracket Mounting Holes 5-1
- FIGURE 5-2 CMA-Lite Cable Management Arm 5-2
- FIGURE 5-3 CMA-800 5-3
- FIGURE 5-4 CMA-800 Upper and Lower Pivot Brackets 5-4
- FIGURE 5-5 Upper and Lower Cable Arms and T-Bracket 5-5
- FIGURE 6-1 Location of the Hard Disk Drives 6-1
- FIGURE 6-2 Releasing the Hard Disk Drive Ejector Handle 6-3
- FIGURE 6-3 Ejecting the Hard Disk Drive 6-3
- FIGURE 6-4 Removing the Hard Disk Drive 6-4
- FIGURE 6-5 Removable Media Module Location—System Front View 6-6
- FIGURE 6-6 Opening the Media Bay Access Door 6-7
- FIGURE 6-7 IB_SSC Assembly Cable and Connector Locations and the Removable Media Module Retaining Spring 6-8
- FIGURE 6-8 Sliding the Removable Media Module Out a Short Distance 6-9
- FIGURE 6-9 Removing the Removable Media Module 6-9
- FIGURE 6-10 Tape Drive and DVD-ROM Drive Location—System Front View 6-11
- FIGURE 6-11 Removing or Attaching the Baseplate to the Tape Drive 6-12
- FIGURE 6-12 Dismantling the Tape Drive Filler Panel 6-13
- FIGURE 6-13 Inserting a Tape Drive Into the System 6-13
- FIGURE 6-14 Opening the Media Bay Access Door—System Top View 6-15
- FIGURE 6-15 Removing the DVD-ROM Drive 6-15
- FIGURE 6-16 IB_SSC Assembly Cable and Connector Locations 6-17
- FIGURE 6-17 DVD-ROM Backplane 6-17
- FIGURE 6-18 System Configuration Card Slot Location 6-19
- FIGURE 6-19 Disconnecting the SCC Reader Cable 6-20
- FIGURE 6-20 Loosening the SCC Reader Captive Screw 6-20

- FIGURE 6-21 Removing the SCC Reader 6–21
- FIGURE 7-1 Disconnecting the Fan Power Connector 7–4
- FIGURE 7-2 Loosening the Fan’s Captive Screw 7–5
- FIGURE 7-3 Removing a Fan 7–5
- FIGURE 7-4 Inserting a Fan Into the Fan Tray 7–6
- FIGURE 7-5 Removing the Fan Tray Power Connector 7–8
- FIGURE 7-6 Loosening the Fan Tray Captive Screws 7–9
- FIGURE 7-7 Removing the Fan Tray 7–10
- FIGURE 7-8 Replacing the System Indicator Board Connector Retaining Clip 7–11
- FIGURE 7-9 Opening the IB Fan Cover—System Top View 7–12
- FIGURE 7-10 Identifying the Fan Power Connector 7–13
- FIGURE 7-11 Removing an IB_SSC Fan 7–14
- FIGURE 8-1 Power Supply Locations 8–1
- FIGURE 8-2 Unlatching a Power Supply 8–3
- FIGURE 8-3 Removing a Power Supply 8–4
- FIGURE 8-4 Removing the Power Inlet Box 8–5
- FIGURE 8-5 Unlatching the Power Distribution Board Ejector Lever 8–7
- FIGURE 8-6 Removing the Power Distribution Board 8–8
- FIGURE 8-7 Inserting the Power Distribution Board 8–9
- FIGURE 9-1 Inserting a CPU/Memory Filler Board 9–2
- FIGURE 9-2 Top View of the CPU/Memory Boards 9–3
- FIGURE 9-3 Unlocking the CPU/Memory Board Ejector Levers 9–5
- FIGURE 9-4 Raising the CPU/Memory Board Ejector Levers 9–6
- FIGURE 9-5 Raising a CPU/Memory Board From the System 9–7
- FIGURE 9-6 Installing a CPU/Memory Board 9–8
- FIGURE 9-7 Partially Inserting the CPU/Memory Board Into the System 9–9
- FIGURE 9-8 Changing Hand Grip and Lowering the CPU/Board Into the System 9–10
- FIGURE 9-9 DIMM Slot Numbers 9–11
- FIGURE 9-10 Removing the DIMM Cover 9–13
- FIGURE 9-11 Removing a DIMM 9–14

- FIGURE 9-12 Installing a DIMM 9-16
- FIGURE 10-1 IB_SSC Assembly Location—System Top View 10-1
- FIGURE 10-2 Opening the Media Bay Cover—System Top View 10-3
- FIGURE 10-3 IB_SSC Assembly Cable and Connector Locations 10-4
- FIGURE 10-4 Unlocking the IB_SSC Assembly Ejector Levers 10-5
- FIGURE 10-5 Raising the IB_SSC Assembly Halfway Using the Antigravity Guides 10-6
- FIGURE 10-6 PCI Bay Location 10-8
- FIGURE 10-7 Opening the PCI Bay Cover 10-10
- FIGURE 10-8 Removing the PCI Card Retaining Screw 10-10
- FIGURE 10-9 Removing a PCI Card 10-11
- FIGURE 11-1 Location of Boards, Modules, and Bays—System Top View 11-1
- FIGURE 11-2 Unlocking the L2 Repeater Board Ejector Levers 11-3
- FIGURE 11-3 Raising an L2 Repeater Board 11-4
- FIGURE 12-1 System Indicator Board LEDs 12-1
- FIGURE 12-2 Removing the System Indicator Board Cover 12-3
- FIGURE 12-3 Removing the System Indicator Board Clip and Connector 12-3
- FIGURE 13-1 Baseplane Location in the System 13-1
- FIGURE 13-2 Removing the Baseplane Securing Screws 13-4
- FIGURE 13-3 Releasing the Baseplane Plunger (If Fitted) 13-4
- FIGURE 13-4 Removing the Baseplane 13-5
- FIGURE 14-1 L2 Repeater Board Clutch Location 14-2
- FIGURE 14-2 CPU/Memory Board Clutch Locations 14-3
- FIGURE 14-3 IB_SSC Assembly Clutch Location 14-4
- FIGURE 15-1 Bezel Hinge Release Mechanism 15-2
- FIGURE B-1 Sun Fire E2900 System External I/O Connections B-2
- FIGURE B-2 RJ-45 Gigabit Ethernet Connectors B-3
- FIGURE B-3 RJ-45 Serial Connectors B-4
- FIGURE B-4 68-Pin SCSI Connector B-5
- FIGURE B-5 RJ-45 Twisted-Pair Ethernet Socket B-7
- FIGURE B-6 DB-15 (Male) Alarms Service Port Connector B-8

Tables

TABLE 1-1	Sun Fire E2900 System Rear View Legend	1-4
TABLE 1-2	FRU LED Status	1-6
TABLE 1-3	SunVTS Documentation	1-8
TABLE 1-4	System Front Panel Icons, LEDs, and Switches	1-10
TABLE 1-5	System LED Functions	1-11
TABLE 1-6	LED Descriptions for Major Boards and the Main Fan Tray	1-13
TABLE 1-7	Additional Troubleshooting Commands	1-15
TABLE 2-1	Safety Precautions	2-2
TABLE 2-2	Symbols	2-3
TABLE 2-3	Overheating Precautions Using Filler Boards and Filler Panels	2-6
TABLE 4-1	On/Standby Switch Operation	4-3
TABLE 6-1	Disk Drive LEDs	6-2
TABLE 7-1	Fan Failure Procedures—One CPU/Memory Board (4 CPUs) Configuration	7-2
TABLE 7-2	Fan Failure Procedures—Two CPU/Memory Boards (8 CPUs) Configuration	7-3
TABLE 7-3	Fan Failure Procedures—Three CPU/Memory Boards (12 CPUs) Configuration	7-3
TABLE 7-4	Main Fan Tray LED Functions	7-7
TABLE 8-1	Power Supply LED Descriptions	8-2
TABLE 9-1	CPU/Memory Board LED Functions	9-4
TABLE 10-1	IB_SCC Assembly LED Functions	10-2
TABLE 11-1	L2 Repeater Board LED Functions	11-2

TABLE A-1	FRUs and Options	A-1
TABLE B-1	Sun Fire E2900 System Back Panel Legend	B-2
TABLE B-2	Gigabit Ethernet Connector Pinout	B-3
TABLE B-3	RJ-45 Serial Connector Pinouts	B-4
TABLE B-4	68-Pin SCSI Connector Pinouts	B-5
TABLE B-5	Twisted-Pair Ethernet Connector Pinouts	B-7
TABLE B-6	Cable Lengths for Twisted-Pair Ethernet and Shielded Twisted-Pair Ethernet Cables	B-7
TABLE B-7	DB-15 (Male) Alarms Service Port Connector	B-8

Preface

This manual describes all the procedures necessary to complete service and maintenance on a Sun Fire™ E2900 system.

How This Book Is Organized

[Chapter 1](#) describes how to isolate faults.

[Chapter 2](#) lists the required safety procedures.

[Chapter 3](#) gives procedures for gaining top access to the system.

[Chapter 4](#) describes how to power off and power on the system.

[Chapter 5](#) describes how to remove and install the cable management arm.

[Chapter 6](#) describes how to replace individual storage devices and the entire removable media bay.

[Chapter 7](#) describes how to replace the various parts of the cooling system.

[Chapter 8](#) explains how to replace the power subsystem components.

[Chapter 9](#) describes how to remove and install CPU/Memory boards, and how to replace DIMMs.

[Chapter 10](#) explains how to remove and install the IB_SSC assembly.

[Chapter 11](#) explains how to remove and install the Level 2 (L2) Repeater boards.

[Chapter 12](#) describes how to replace the service indicator board.

[Chapter 13](#) describes how to replace the baseplane.

[Chapter 14](#) describes how to replace the antigravity clutch mechanism.

[Chapter 15](#) describes how to replace the side handles.

[Appendix A](#) contains details of individual field-replaceable parts.

[Appendix B](#) provides illustrations of connectors and pinouts.

Glossary contains definitions of technical terms used in this book.

Typographic Conventions

Typeface*	Meaning	Examples
AaBbCc123	The names of commands, files, and directories; on-screen computer output	Edit your <code>.login</code> file. Use <code>ls -a</code> to list all files. % You have mail.
AaBbCc123	What you type, when contrasted with on-screen computer output	% su Password:
<i>AaBbCc123</i>	Book titles, new words or terms, words to be emphasized	Read Chapter 6 in the <i>User's Guide</i> . These are called <i>class</i> options. You <i>must</i> be superuser to do this. To delete a file, type <code>rm filename</code> .

* The settings on your browser might differ from these settings.

Shell Prompts

Shell	Prompt
C shell	<i>machine-name%</i>
C shell superuser	<i>machine-name#</i>
Bourne shell and Korn shell	\$
Bourne shell and Korn shell superuser	#
LOM prompt	lom>

Related Documentation

Other useful books for the Sun Fire E2900 system include:

- *Sun Fire E2900 System Site Planning Guide*
- *Sun Fire E2900 Systems Unpacking Guide*
- *Sun Fire E2900 System Installation Guide*
- System administration manual for this product

Accessing Sun Documentation

You can view and print a broad selection of Sun™ documentation, including localized versions, at:

<http://www.sun.com/documentation>

Contacting Sun Technical Support

If you have technical questions about this product that are not answered in this document, go to:

<http://www.sun.com/service/contacting>

Sun Welcomes Your Comments

Sun is interested in improving its documentation and welcomes your comments and suggestions. You can submit your comments by going to:

<http://www.sun.com/hwdocs/feedback>

Please include the title and part number of your document with your feedback:

Sun Fire E2900 System Service Manual, part number 817-4054-11

Cautions and Notes



Caution – This equipment contains lethal voltages. Accidental contact with centerplane, card cage, and drive areas can result in serious injury or death.



Caution – Improper handling by unqualified personnel can cause serious damage to this equipment. Unqualified personnel who tamper with this equipment may be held liable for any resultant damage to the equipment.

Individuals who remove any outer panels or open covers to access this equipment must observe all safety precautions and ensure compliance with skill level requirements, certification, and all applicable local and national laws.

Procedures contained in this document must be performed by qualified service-trained maintenance providers.

Note – Before you begin, carefully read each of the procedures in this manual. If you have not performed similar operations on comparable equipment, *do not attempt* to perform these procedures.

Fault Isolation

This chapter describes how to troubleshoot the system and includes the following topics:

- [Section 1.1, “System Identification” on page 1-1](#)
- [Section 1.2, “Basic Troubleshooting” on page 1-5](#)
- [Section 1.3, “SunVTS Software” on page 1-7](#)
- [Section 1.4, “Other Fault Isolation Aids” on page 1-8](#)

You can also find procedures and information in the system administration manual.

1.1 System Identification

This section provides front, rear, and top views of the Sun Fire E2900 system. [FIGURE 1-1](#) shows a top view of the system where many boards and other devices are located. [FIGURE 1-2](#) shows the interior front view of the system where power supplies, fans, fan trays, and storage devices are located. [FIGURE 1-3](#) shows the location of the ports, connectors, and the power distribution board on the Sun Fire E2900 system.

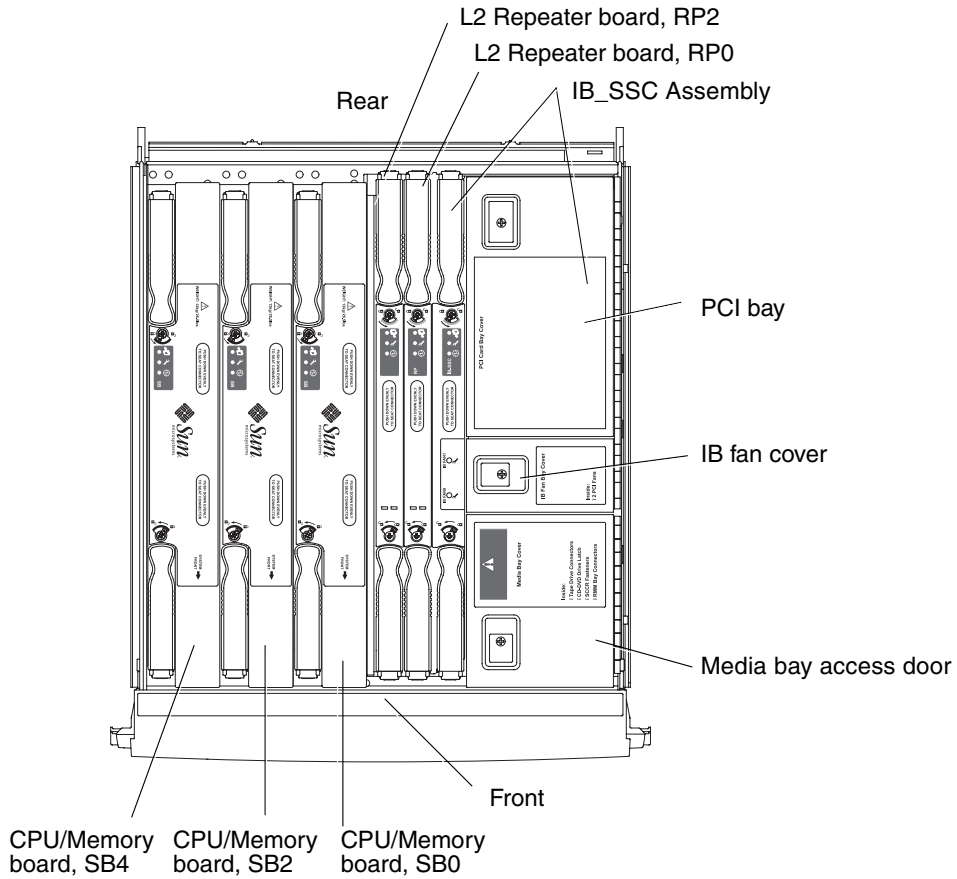

FIGURE 1-1 System Top View

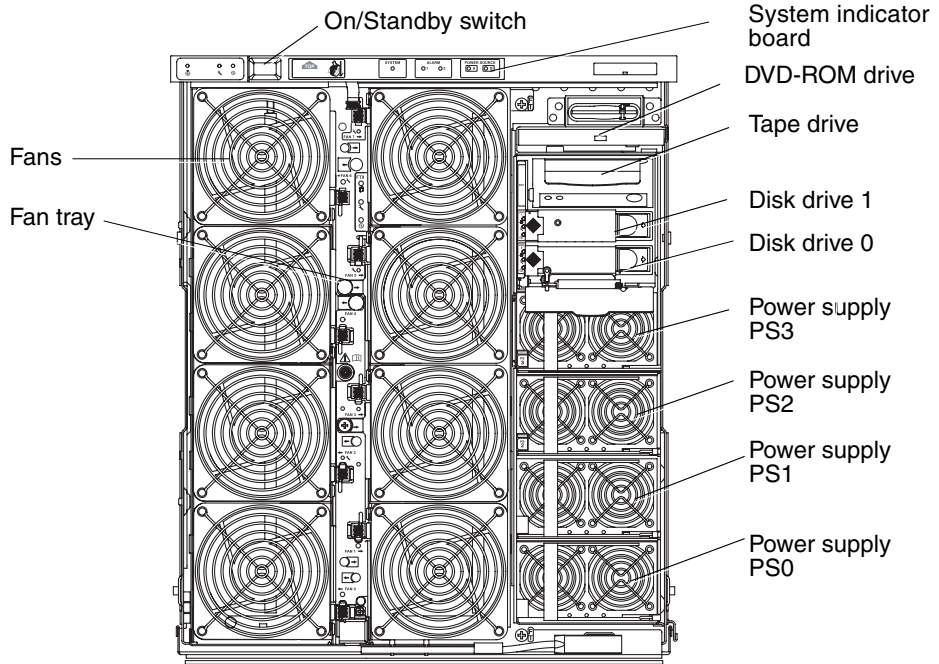

FIGURE 1-2 System Front View

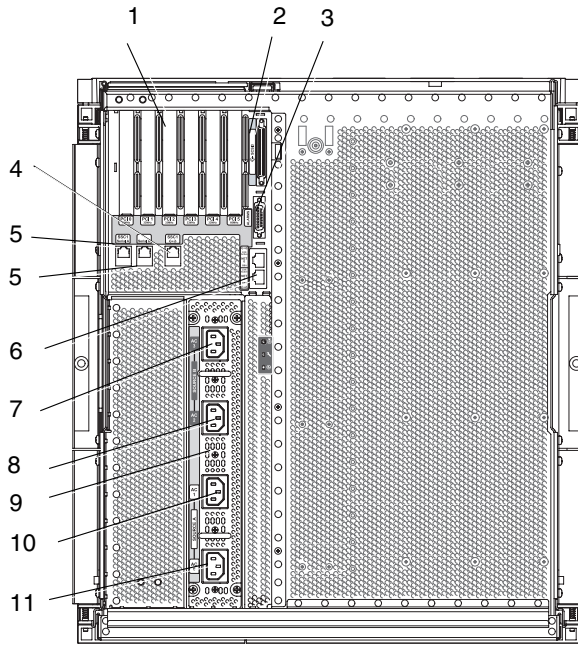

FIGURE 1-3 System Rear View

TABLE 1-1 Sun Fire E2900 System Rear View Legend

Number	Description
1	PCI0–PCI5 connectors
2	SCSI port, 68 pins
3	Alarms port
4	10/100 Ethernet LOM/system controller port
5	Serial ports
6	Net0/Net1 ports
7	AC3 input port
8	AC2 input port
9	AC power inlet box
10	AC1 input port
11	AC0 input port

1.2 Basic Troubleshooting

In a functioning Sun Fire E2900 system without any known problems, the system should not display any error conditions. For example:

- System fault LED should not be lit.
- Fault LEDs on all field-replaceable units (FRUs) should not be lit.
- `syslog` file should not display error messages.
- Administrative console should not display error messages.
- System controller logs should not display any error messages. See the Troubleshooting chapter of the system administration manual for more information.
- Solaris Operating System (Solaris OS) message files should not indicate any additional errors. See the Troubleshooting chapter of the system administration manual for this product for more information on the various message files.

If a problem or failure occurs, the system controller does the following:

- Attempts to determine what hardware is faulty
- Takes steps to prevent that hardware from being used until it has been replaced

Some of the specific actions the system controller takes include:

- May cause the hardware to pause while software analyzes and records the event error
- Determines whether or not the error is recoverable and if the system needs to be reset
- When possible, causes the faulty FRU to provide an LED indication of a fault in addition to populating the system console messages with further details
- Determines if dynamic deconfiguration and reconfiguration is applicable

If the system cannot diagnose the problem, see the following sections for troubleshooting information.

1.2.1 Power Distribution

To troubleshoot the power distribution system, do the following:

1. **Ensure that all cabling is properly connected.**
2. **Check that switch positions are correct on all involved FRUs.**
3. **Check that the LEDs on the involved FRUs are as indicated in the following sections.**

1.2.1.1 Normal Operation

The LED status of all FRUs in a properly operating Sun Fire E2900 system is described in [TABLE 1-2](#).

TABLE 1-2 FRU LED Status

FRU	LED Status in Standby Mode	LED Status After Power On
Power supplies	Green Power LEDs blinking All other LEDs off	Power LEDs green All other LEDs off
System boards	IB_SSC Power LED green All other LEDs off	Power LEDs green All other LEDs off
Main fans and fan tray	Fan tray Power LED green All other LEDs off	Fan tray Power LED green All other LEDs off
IB fans	All LEDs off	All LEDs off
Hard disk drives	All LEDs off	Power LEDs green All other LEDs off

1.2.1.2 Abnormal Operation

When an abnormal condition of faulty incoming power exists, the amber fault LED () is lit on one or more of the involved FRUs.

1.2.2 Main Fans

The system has a fan tray assembly that cools all components in the system. There are eight hot-swappable main fans in the fan tray. To determine if a fan in the fan tray is faulty:

1. **Inspect the fan LEDs. Determine if one or more fault LEDs () on each fan is lit, which means there is an internal fault or failure.**

See [Section 1.4.1, “Interpreting LEDs”](#) on page 1-9 and [TABLE 7-4](#).

If a fan in the fan tray is faulty, the system controller changes the fan speed of the remaining working fans to high speed to compensate for reduced air flow.

2. **Replace the faulty fan. The fans are hot-swappable.**

See [Section 7.1.2, “Removing a Main Fan”](#) on page 7-4 and [Section 7.1.3, “Installing a Main Fan”](#) on page 7-6.

1.2.3 System Controller

The system controller receives error messages from each of the boards and determines the appropriate actions to take. Typical actions include:

- Setting the appropriate error status bits
- Asserting error pause to stop further address packets
- Interrupting the system controller

1.3 SunVTS Software

The SunVTS™ software executes multiple diagnostic hardware tests from a single user interface. The SunVTS software verifies the configuration, functionality, and reliability of most hardware controllers and devices. For more information on the SunVTS software, see [TABLE 1-3](#).

TABLE 1-3 SunVTS Documentation

Title	Description
<i>SunVTS User's Guide</i>	Describes the SunVTS environment; starting and controlling various user interfaces; feature descriptions.
<i>SunVTS Test Reference Manual</i>	Describes each SunVTS test; provides various test options and command-line arguments.
<i>SunVTS Quick Reference Card</i>	Provides an overview of vtsui interface features.

1.4 Other Fault Isolation Aids

There are a number of additional system fault isolation aids, such as:

- System and individual board and assembly LEDs
- Sun™ Management Center software
- OpenBoot™ PROM firmware

These items are discussed in the following sections:

- [Section 1.4.1, "Interpreting LEDs" on page 1-9](#)
- [Section 1.4.2, "Dynamic Reconfiguration \(DR\)" on page 1-14](#)
- [Section 1.4.3, "Sun Management Center Software and SunSolve OnLine" on page 1-14](#)
- [Section 1.4.4, "OpenBoot Firmware" on page 1-14](#)
- [Section 1.4.5, "Other Utilities" on page 1-15](#)

1.4.1 Interpreting LEDs

Use the LEDs on the individual system components to determine if the system is operating normally. Routinely monitor the LEDs on the following boards and devices:

- System controller and I/O assembly (IB_SSC)
- CPU/Memory board
- L2 Repeater boards
- Fan trays
- Power supplies

When the fault () LED is on (lit), this indicates that a fault has occurred in the system, and you should take immediate action to clear the fault. [TABLE 1-5](#) lists the LED status codes for the system and for the following hot-swappable components:

- CPU/Memory boards
- Power supplies
- Fans (main and IB)
- Hard disk drives

You can only remove a hot-swappable powered-up component when the OK to remove is lit.

Note – The fan tray, IB_SSC, and L2 Repeaters *are not* hot-swappable. You must power off the system in order to remove them.

Note – The main fans and the IB fans do not have OK to remove LEDs.

1.4.1.1 System Enclosure LEDs

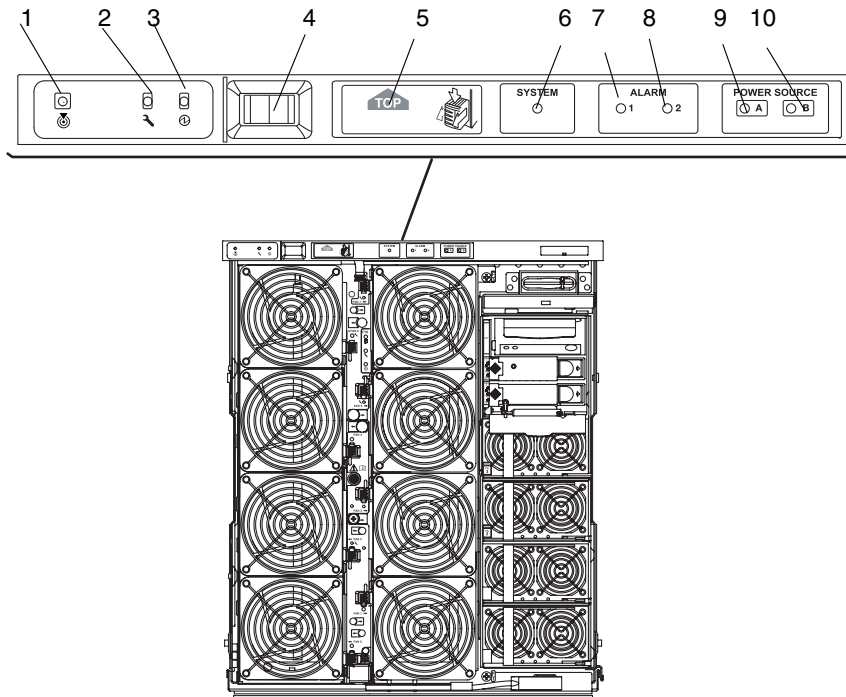









FIGURE 1-4 System Front Panel LEDs

TABLE 1-4 System Front Panel Icons, LEDs, and Switches

Number	LED or Switch Name
1	Locator
2	System fault
3	System active
4	On/Standby switch
5	Top access required
6	Solaris OS running
7	Alarm 1
8	Alarm 2
8	Source A
10	Source B

TABLE 1-5 lists the system LED functions (FIGURE 1-4).

TABLE 1-5 System LED Functions

LED Icon and Name	Color	LED On	LED Off
 Locator	White	Normally off. Can be lit by user command. Notes location of system.	Can be lit by user command. No one has requested the location of the system.
 System Fault	Amber	Fault is detected. Service is required.	No fault is detected.
 System Active	Green	System is being powered on or is powered on.	System is in Standby.
 Top Access	Amber	Fault occurs in a FRU, which can only be replaced from the top of the system.	No fault occurs in a FRU that can only be replaced from the top of the system.
SYSTEM 	Green	Solaris OS is running.	Solaris OS is not running or the domain is paused.
ALARM 	Green	Triggered by events as specified in the LOM software. <ul style="list-style-type: none"> • Can customize alarms. For example Alarm 1 can be used for degraded mode and Alarm 2 can be used for final or shutdown mode. • LOM software provides paths so you can link the alarms to Solaris OS events. • Can also associate alarms to specific user applications or processes. 	Not triggered by events as specified in the LOM software.
POWER SOURCE 	Green	Displays the state of the power sources—source A supplies power to PS0 and PS1 while source B supplies power to PS2 and PS3. <ul style="list-style-type: none"> • Source A lit if either PS0 or P1 receives input power. • Source B lit if either PS2 or P3 receives input power. 	<ul style="list-style-type: none"> • Source A not lit if PS0 and P1 do not receive input power. • Source B not lit if PS2 and P3 do not receive input power.

The system locator, fault, and system active LEDs are repeated on the front and rear of the system. FIGURE 1-5 illustrates the LEDs on the rear of the system.

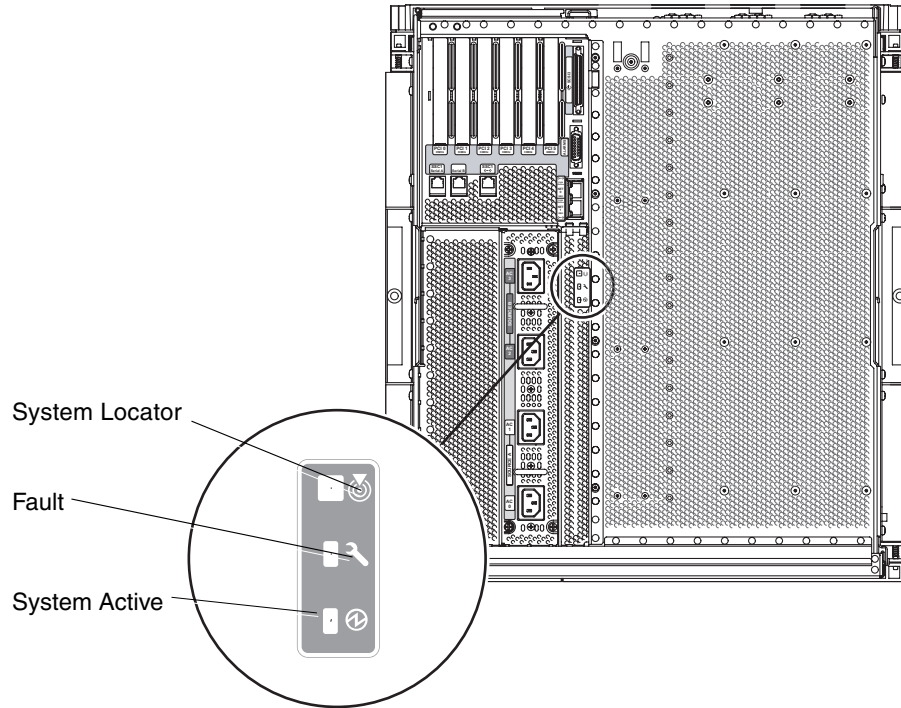





FIGURE 1-5 Rear Panel System LEDs

1.4.1.2 Board or Component LEDs

TABLE 1-6 describes the LEDs and their functions for the following boards or assemblies:

- CPU/Memory board
- L2 Repeater board
- IB_SCC assembly
- Main fan tray

TABLE 1-6 LED Descriptions for Major Boards and the Main Fan Tray

Power* (Green)	Fault (Amber)	OK to Remove (Blue or Amber)		
				
			Indication	Corrective Action
Off	Off	Off	Component not operating.	You can remove the component from the system.
Off	On	Off	Component not operating. Fault condition present.	You cannot remove the component from the system.
Off	Off	On	Component not operating. No fault condition present.	You can remove the component from the system.
Off	On	On	Component not operating. Fault condition present.	You can remove the component from the system.
On	Off	Off	Normal component operation.	N/A.
On	Off	On	Component not operating. No fault condition present.	You can remove the component from the system.
On	On	Off	Component operating. Fault condition present.	You cannot remove the component from the system.
On	On	On	Component operating. Fault condition present.	You can remove the component from the system.

* Not applicable to fans.

See the chapter describing board or component removal and replacement procedures for general summary information on each LED state.

1.4.2 Dynamic Reconfiguration (DR)

The Dynamic Reconfiguration (DR) software is part of the Solaris OS. With DR you can dynamically reconfigure CPU/Memory boards in order to safely remove them or install them into a system while the Solaris OS is running. DR is performed with minimum disruption to user processes running in the system.

The process of replacing a board while the system is still running is called hot-plugging. DR provides this software hot-plug support. For more information on DR, refer to Chapter 1, “Overview” and Chapter 9 “CPU/Memory Board Replacement and Dynamic Reconfiguration (DR)” in the system administration manual.

1.4.3 Sun Management Center Software and SunSolve OnLine

The Sun™ Management Center software, which monitors system functioning, is not supported on this system.

1.4.4 OpenBoot Firmware

The OpenBoot™ firmware is executed immediately after you turn on the system. The primary tasks of the OpenBoot firmware are:

- Testing and initializing the system hardware
- Determining the system hardware
- Booting the operating system
- Providing interactive debugging facilities for testing hardware and software

For more information, refer to the *OpenBoot 4.x Command Reference* manual.

1.4.5 Other Utilities

For additional troubleshooting information, use the commands described in [TABLE 1-7](#).

TABLE 1-7 Additional Troubleshooting Commands

Command	Description
<code>prtfru</code>	Obtains FRU-ID data from the system (Solaris OS command). Refer to the <code>prtfru</code> man page and the Solaris OS documentation for more details.
<code>inventory</code>	Shows the contents of the serial EPROM (SEEPROM) (system controller command). Refer to the system controller manual for more details.

Safety, Tools Requirements, and Periodic Maintenance

This chapter describes the safety and system precautions you must take when servicing the system. It lists the tools and equipment you will need as well as basic periodic maintenance. This chapter includes the following topics:

- [Section 2.1, “Safety Precautions” on page 2-2](#)
- [Section 2.2, “Symbols” on page 2-3](#)
- [Section 2.3, “Electrical Safety Precautions” on page 2-4](#)
- [Section 2.4, “System Cabinet Safety Precautions” on page 2-4](#)
- [Section 2.5, “Handling Boards and Assemblies” on page 2-5](#)
- [Section 2.6, “Extending the System Cabinet Stabilizer Bar” on page 2-6](#)
- [Section 2.7, “Filler Boards and Filler Panels” on page 2-6](#)
- [Section 2.8, “Antistatic Precautions” on page 2-6](#)
- [Section 2.9, “Tools Required” on page 2-8](#)
- [Section 2.10, “Removing and Replacing the Front Doors” on page 2-8](#)
- [Section 2.11, “Periodic Maintenance” on page 2-10](#)

2.1 Safety Precautions

For your protection, observe the following safety precautions when setting up your equipment:

- Follow all cautions, warnings, and instructions marked on the equipment.
- Never push objects of any kind through openings in the equipment, as they may touch dangerous voltage points or short out components that could result in fire or electric shock.
- Refer servicing of equipment to qualified personnel.









To protect both yourself and the equipment, observe the following safety precautions:

TABLE 2-1 Safety Precautions

Item	Problem	Precaution
ESD jack/wrist or foot strap	Electrostatic Discharge (ESD)	The system has four ESD connections. Connect the ESD connector to your system and wear the wrist strap or foot strap when handling printed circuit boards.
ESD mat	Electrostatic Discharge (ESD)	An approved ESD mat provides protection from static damage when used with a wrist strap or foot strap. The mat also cushions and protects small parts that are attached to printed circuit boards.
ESD packaging box	Electrostatic Discharge (ESD)	Place the board or component in the ESD safe packaging box after you remove it. The CPU/Memory board packaging box provides two ESD safe work surfaces.

2.2 Symbols

TABLE 2-2 Symbols

Symbol	Description	Meaning
	CAUTION	Hazardous voltages are present. To reduce the risk of electrical shock and danger, follow the instructions.
	CAUTION	Risk of personal injury or equipment damage. To reduce the risk, follow the instructions.
	HOT SURFACE	Hot surfaces. Avoid contact. Surfaces are hot and may cause personal injury if touched.
	COMPONENT ACTIVATED	Component or system is active when the green Active LED is lit.
	OK TO REMOVE	You can safely remove board or component from the system when the OK to remove LED (blue or amber) is lit.
	FAULT	The component or system has a fault when the Fault LED (amber) is lit.
	LOCATOR	The locator LED (white) is lit, when it is activated by service personnel in order to locate the appropriate system or FRU.
	PROTECTIVE EARTH	Protective ground.
	CHASSIS	Frame or chassis ground.

2.3 Electrical Safety Precautions

Ensure that the voltage and frequency of the power outlet to be used match the electrical rating labels on the equipment.

Wear antistatic wrist straps when handling any magnetic storage devices, system boards, or other printed circuit boards.

Use only properly grounded power outlets as described in the installation guide.



Caution – *Do not* make mechanical or electrical modifications. Sun Microsystems™ is not responsible for regulatory compliance of modified systems.



Caution – The chassis AC power cords must remain connected to ensure a proper ground.

2.4 System Cabinet Safety Precautions

All system cabinets should be anchored to the floor, ceiling, or to adjacent frames, using the manufacturer's instructions.

Free-standing cabinets should be supplied with an anti-tilt feature, which must be extended to a minimum of 10.6 inches (27 cm) from the front edge of the rack, or at least sufficiently to support the weight of the system when extended on its slides. This prevents instability during installation or service actions.

Where an anti-tilt feature is not supplied and the system cabinet is not bolted to the floor, a safety evaluation must be conducted by the installation or service engineer. The safety evaluation determines the cabinet stability when the system is extended on its slides, prior to any installation or service activity.

Prior to installing the system cabinet on a raised floor, a safety evaluation must be conducted by the installation or service engineer. The safety evaluation ensures that the raised floor has sufficient strength to withstand the forces upon it when the system is extended on its slides. The normal procedure in this case would be to fix the system cabinet through the raised floor to the concrete floor below, using a proprietary rackmounting kit for the purpose.



Caution – If more than one system is installed in a system cabinet, service only one system at a time.

2.5 Handling Boards and Assemblies



Caution – There is a separate chassis ground located on the rear of the system. It is important to ensure that the system is properly grounded.



Caution – The system is sensitive to static electricity. To prevent damage to the board, connect an antistatic wrist strap between you and the system.



Caution – The boards have surface-mount components that can be broken by flexing the boards.

To minimize the amount of board flexing, observe the following precautions:

- Hold the board only by the handle and by the green fingerhold panels, where the board stiffener is located. Do not hold the board *only* at the ends.
- When removing the board from the packaging, keep the board vertical until you lay it on the cushioned ESD mat.
- Do not place the board on a hard surface. Use a cushioned antistatic mat. The board connectors and components have very thin pins that bend easily.
- Be careful of small component parts located on both sides of the board.
- Do not use an oscilloscope probe on the components. The soldered pins are easily damaged or shorted by the probe point.
- Transport the board in its packaging box.



Caution – The heatsinks can be damaged by incorrect handling. Do not touch the heatsinks while replacing or removing boards. If a heatsink is loose or broken, obtain a replacement board.



Caution – The heatsinks can be damaged by improper packaging. When storing or shipping a board, ensure that the heatsinks have sufficient protection.

2.6 Extending the System Cabinet Stabilizer Bar

To slide the system out of or into the cabinet and extend the stabilizer bar, see [Section 3.1, “Sliding the System Out of the System Cabinet” on page 3-1](#) and [Section 3.2, “Sliding the System Into the System Cabinet” on page 3-5](#).

2.7 Filler Boards and Filler Panels

Filler boards and panels, which are physically inserted into the board or card slot, are used for EMI protection and for air flow ([TABLE 2-3](#)).

TABLE 2-3 Overheating Precautions Using Filler Boards and Filler Panels

If you remove	Do the following
CPU/Memory board	Install a filler board in a system to prevent the system from overheating.
Tape drive or PCI card	In order to provide full EMI protection, ensure that filler panels are installed when removing the tape drive or PCI card.

2.8 Antistatic Precautions



Caution – Wear an antistatic wrist strap and use an ESD-protected mat when handling components. Attach the antistatic wrist strap to the press stud at the rear or side of the chassis before removing any covers or components.

There are four antistatic strap attachment points on the chassis:

- Right side towards the front ([FIGURE 2-1](#))
- Left side towards the front
- Center at the rear
- Center of the fan tray assembly, at the front

- To attach the antistatic wrist strap to the chassis, connect the strap as shown in [FIGURE 2-1](#).

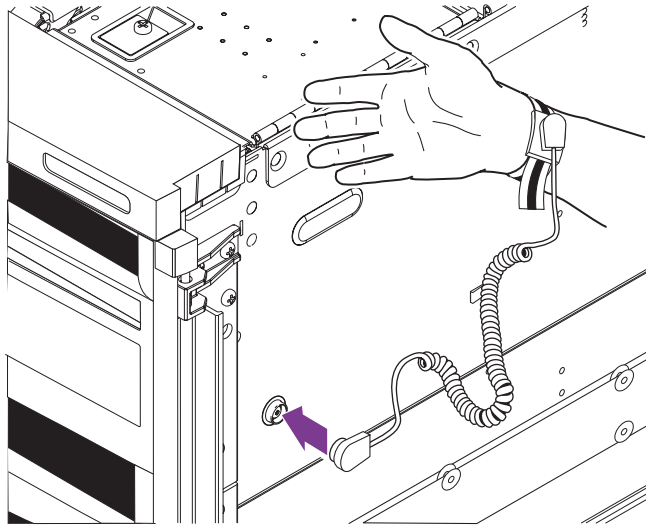

FIGURE 2-1 Attaching the Antistatic Wrist Strap—Right Side



Caution – Attach the cord to the antistatic wrist strap directly to the system. Do not attach the antistatic wrist strap to the ESD mat connection.

The antistatic wrist strap and any components you remove must be at the same potential.

2.9 Tools Required

For the procedures in this document, you will need these tools:

- Screwdriver, Phillips no. 2
- Screwdriver Phillips no. 2, 6-inch shank (15 cm) (for baseplane removal)
- Needlenose pliers (for connector removal)
- Torque wrench and extension (supplied)
- ESD mat and grounding wrist strap or foot strap
- Safety platform

2.10 Removing and Replacing the Front Doors

2.10.1 Removing the Front Doors

There are two doors on the front of the system.:

1. **Open both doors by pressing the latches at the center of each door** ([FIGURE 2-2](#)).

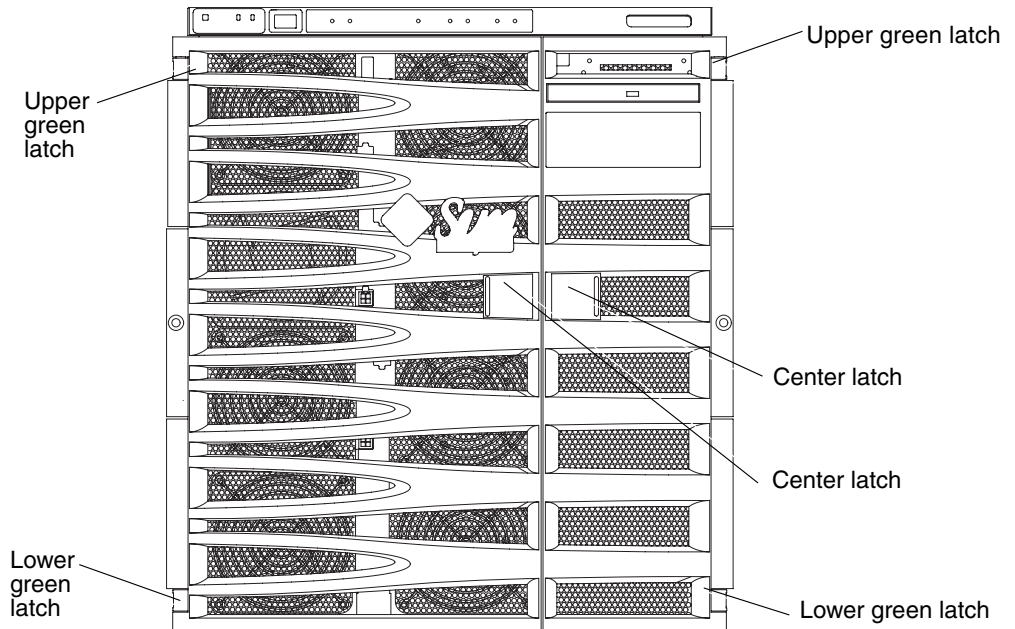

FIGURE 2-2 Front View of System

2. Remove one door.
 - a. While holding the door with one hand, push the green latch on the top of the door down (FIGURE 2-2).
 - b. Move the door downwards; the door will unlatch from the bottom green latch.
3. Remove the other door. Repeat [Step 2](#).

2.10.2 Replacing the Front Doors

1. While holding the door with one hand, align the left door with the screw coming from the green latch at the bottom. Hold the green latch down in order to properly align the door with the screw (FIGURE 2-3).

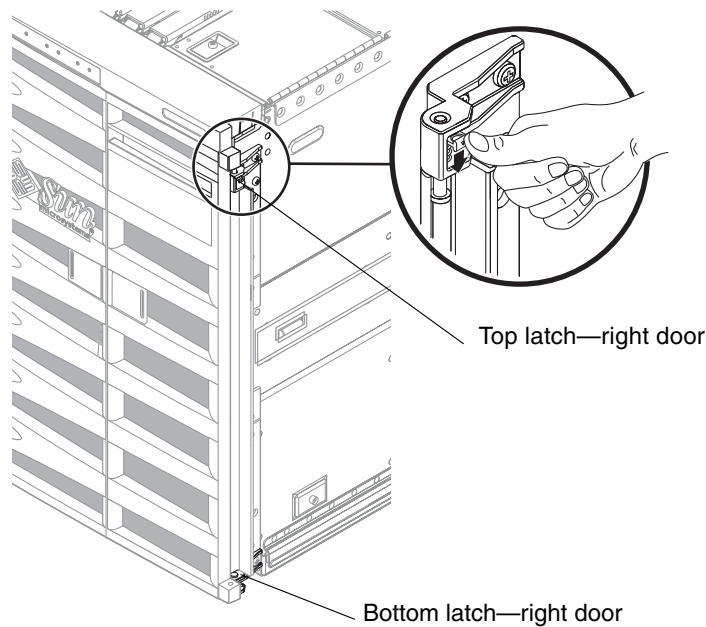

FIGURE 2-3 Front Door Latches

2. Align the left door to the upper screw coming out of the upper green latch. Press the green latch down to properly align the door with the screw.
Make sure both the top and bottom of the door are securely fastened.
3. Replace the other door. Repeat [Step 1](#) through [Step 2](#).
4. Close both doors.

2.11 Periodic Maintenance

You must clean or change the air filters periodically.

2.11.1 Replacing or Cleaning the Air Filters

The Sun Fire E2900 system has two air filters that require periodic inspection and cleaning. You can clean or change the air filters in the system without powering off the system.

Note – Do not clean the air filters when they are attached to the system. Remove the front doors with the air filters attached. See [Section 2.10.1, “Removing the Front Doors”](#) on page 2-8.



Caution – Keep the amount of time that unfiltered air passed through the system to a minimum. Running the system without air filters will not protect the system from drawing in debris from the air. Have spare air filters on-site so that replacement air filters are available when needed.

1. Open and remove the front doors.

See [Section 2.10.1, “Removing the Front Doors”](#) on page 2-8.

2. Locate the two air filters (FIGURE 2-4 and FIGURE 2-5).

The air filters are located behind the front doors of the system.

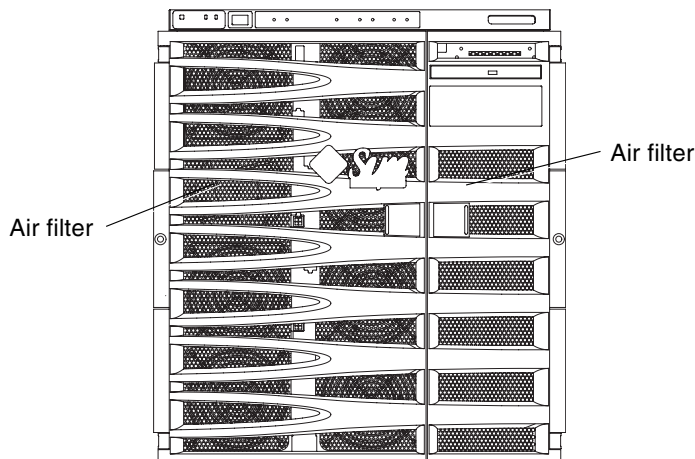

FIGURE 2-4 Location of the Air Filters

3. Inspect the air filter for debris and trapped particles every three months of operation.

Consider the level of debris found on the air filter when scheduling a time to remove and clean the air filter.

4. If the air filter collects a considerable amount of debris in less than three months, investigate the air supply system for sources of contamination and take corrective action.

5. Remove the air filters.

6. Clean the air filters or install new replacement air filters.

Keep the amount of time that unfiltered air passed through the system to a minimum. See the Caution earlier in this section.

- If you are going to clean the air filters:
 - Wash them in warm soapy water and let them air-dry.
Alternatively, you can also use compressed air to dry the filter.

Caution – Do not replace them until they have air dried.

- Reinstall the air filters (FIGURE 2-5).
- If you are going to install replacement filters, install them into the system (FIGURE 2-5).

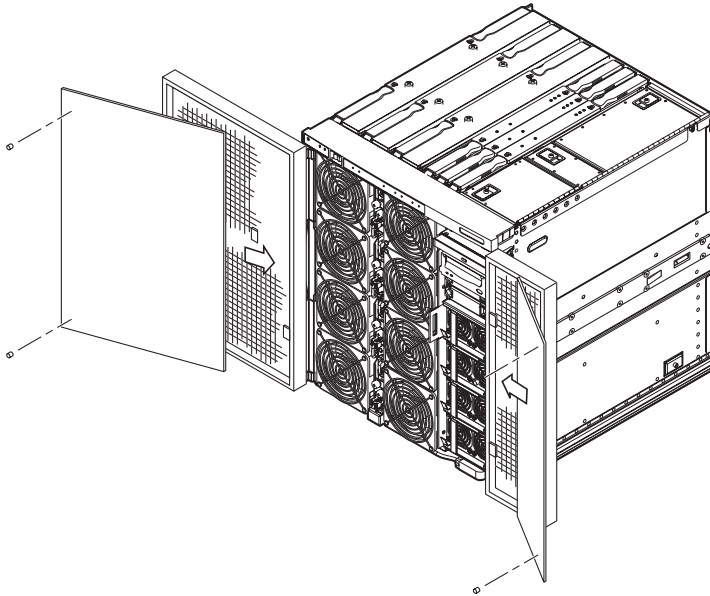

FIGURE 2-5 Installing the Sun Fire E2900 System Air Filters

7. Close then replace the front doors.

See [Section 2.10.2, “Replacing the Front Doors”](#) on page 2-9.

System Access and Transportation

This chapter describes the following topics:

- Section 3.1, “Sliding the System Out of the System Cabinet” on page 3-1
- Section 3.2, “Sliding the System Into the System Cabinet” on page 3-5
- Section 3.3, “Transporting the System” on page 3-5



Caution – Observe system cabinet safety precautions. See [Chapter 2](#).

3.1 Sliding the System Out of the System Cabinet

You need to slide the system out of the system cabinet in order to service the following FRUs:

- Removable media module
- System configuration card (SCC) reader
- IB (Interface board—I/O assembly) fans
- Power distribution boards
- CPU/Memory boards
- DIMMs
- IB_SSC assembly (I/O assembly and system controller)
- PCI cards
- L2 Repeater boards
- System indicator board
- Baseplane
- Clutch for the CPU/Memory board, L2 Repeater board, IB_SSC assembly
- Side handles

1. Make sure that the leveling feet are extended to the floor.
2. Extend and lock the system cabinet stabilizer bar (FIGURE 3-1).



Caution – Failure to extend and lock the stabilizer bar before you slide a system out of the system cabinet can cause the system cabinet to tip over.

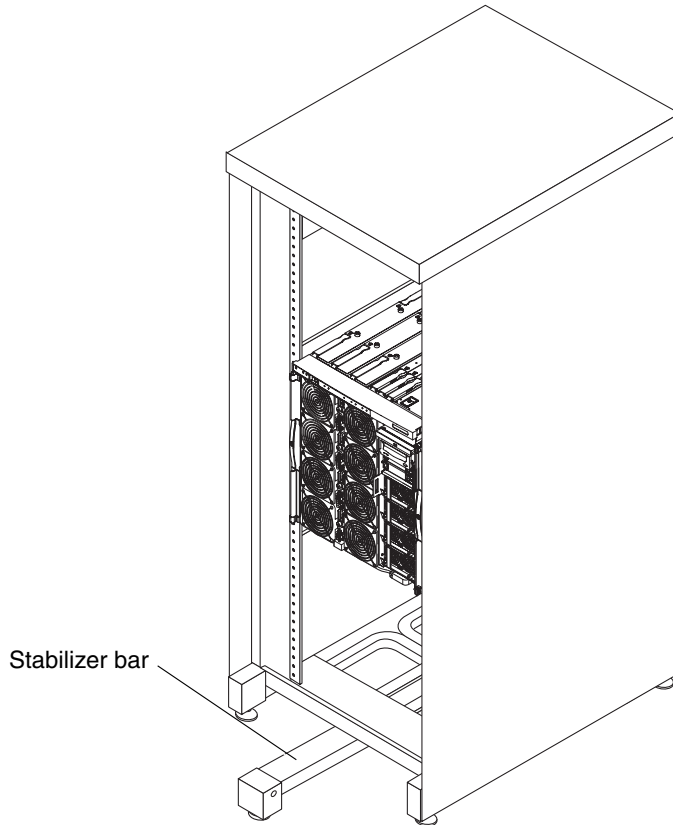

FIGURE 3-1 Sun Rack 900 System Cabinet With Stabilizer Bar Extended

3. From the front, carefully pull the system forward out of the system cabinet until the locking latches click (FIGURE 3-2).

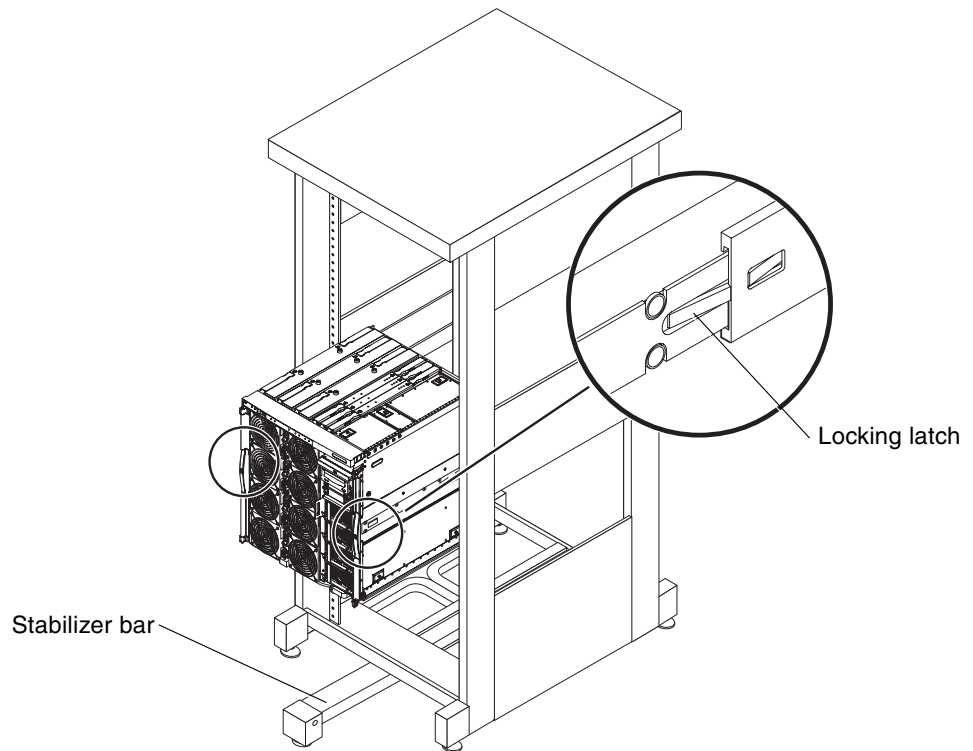

FIGURE 3-2 Sliding the System Out of the System Cabinet

4. Loosen the captive screws on the side handles (FIGURE 3-3).

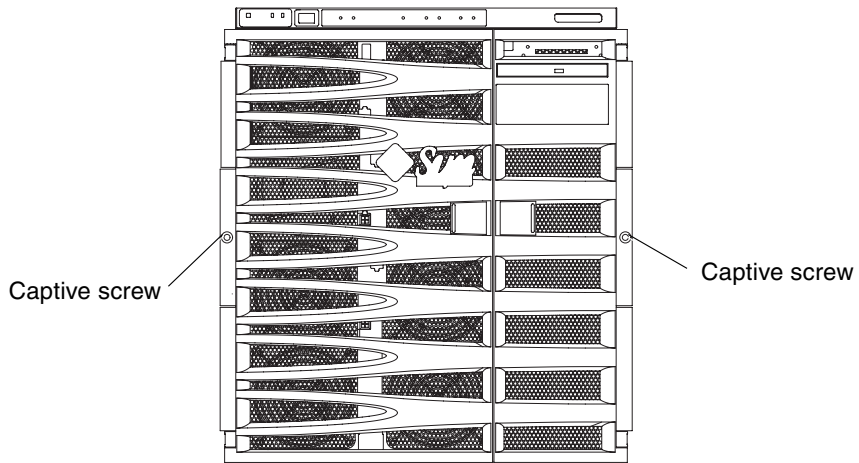

FIGURE 3-3 Side Handles Captive Screws

5. Loosen, but do not remove, the slide locking nuts at the rear of the system (FIGURE 3-3).

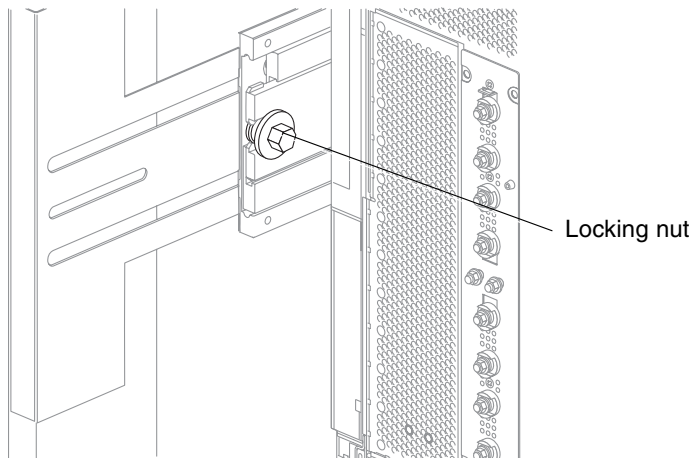

FIGURE 3-4 Slide Locking Nut

3.2 Sliding the System Into the System Cabinet

1. Make sure that the leveling feet are extended to the floor.
2. Make sure that the system cabinet stabilizer bar is extended and locked (FIGURE 3-2).
3. From the front of the system, slide the system into the system cabinet.
4. Tighten the captive screws on the side handles (FIGURE 3-3).
5. Tighten the slide locking nuts at the rear of the system (FIGURE 3-4)
6. Retract the system cabinet stabilization bar (FIGURE 3-2).

3.3 Transporting the System

This section describes these procedures:

- [Section 3.3.1, “Transporting the System Between Cabinets” on page 3-5](#)
- [Section 3.3.2, “Transporting the System Cabinet With Installed Systems” on page 3-13](#)
- [Section 3.3.3, “After Transporting the System Cabinet With Systems Installed” on page 3-14](#)

3.3.1 Transporting the System Between Cabinets

If you need to transport the system from one system cabinet to another system cabinet, attach the shipping cradle (also referred to as a plinth). The shipping cradle protects the bottom of the system during transit and handling.

Note – Use a lifting device to transport the system mounted on the shipping cradle.

3.3.1.1 Securing the System on the Shipping Cradle

1. If the handles are not attached to the shipping cradle, attach them now:

Note – In the following illustrations, right and left orientation are as you face the word “FRONT” on the base plate (FIGURE 3-5). The top and bottom halves of the base plate are identical. Start with either the top or bottom half facing upward.

- c. Align the two guide posts on the handle with the entry holes on the L-shaped shipping cradle slide cutouts (FIGURE 3-5).

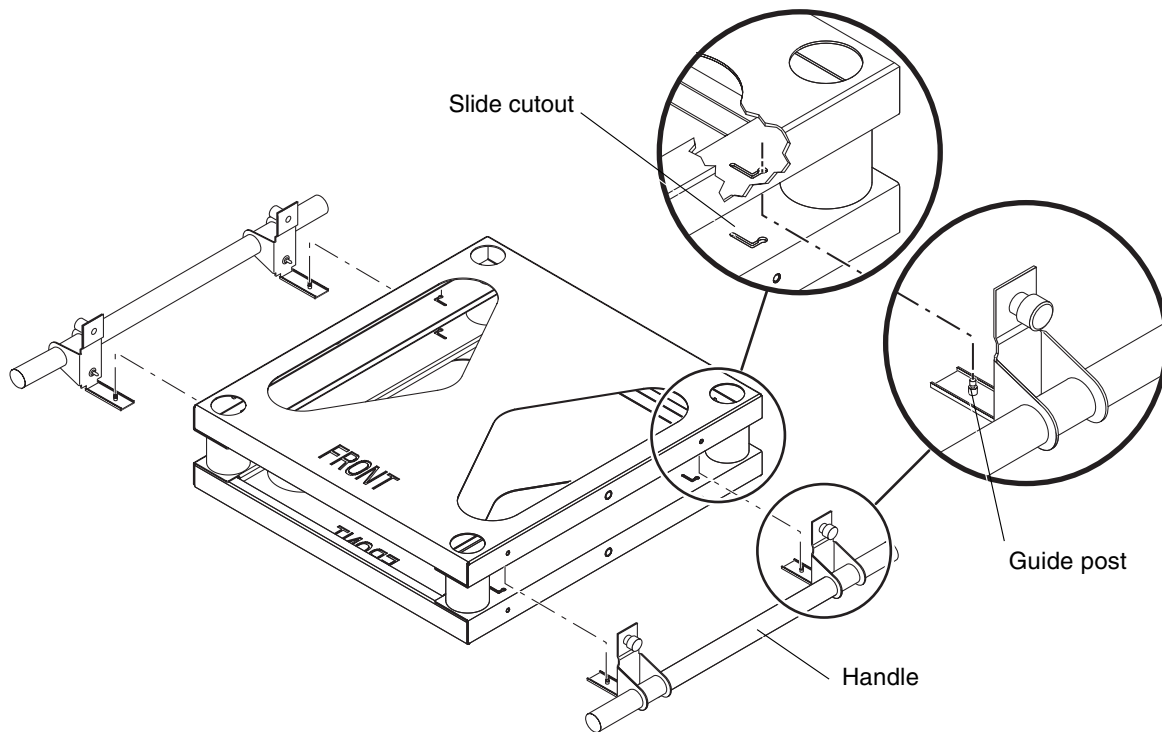

FIGURE 3-5 Shipping Cradle Details

- d. Raise the handle so that the tops of the front and rear guide posts fit into the entry holes in the cutouts (FIGURE 3-5 and FIGURE 3-6).
The grooves in the guide posts fit into the narrow slots in the cutouts.
- e. Slide the handle and guide posts toward the front of the shipping cradle (FIGURE 3-6).

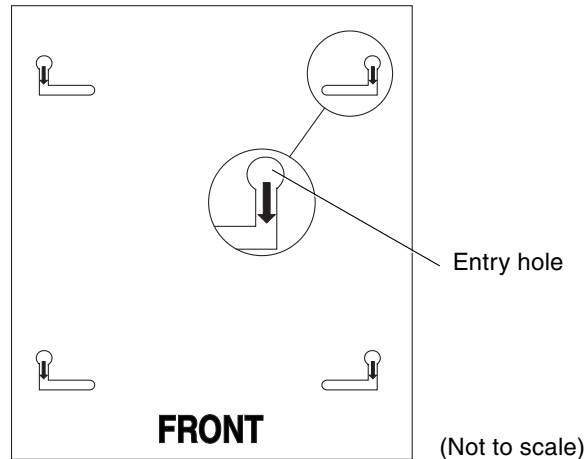

FIGURE 3-6 Slide Cutouts

Note – Do not tighten the captive screws on the handles. Leave both handles loosely attached. There must be room between the handles to place the system on the shipping cradle.

- f. Attach the other handle in the same manner. Complete [Step a](#) through [Step e](#).
2. Extend the cabinet stabilizer and lock it in position.
3. Disconnect the cables attached to the system.
4. Remove the cable management arm (CMA) from the rear of the system (if installed).
See [Section 5.1.1, “Removing the CMA-Lite”](#) on page 5-2 or [Section 5.2.1, “Removing the CMA-800”](#) on page 5-3.
5. (Optional) Remove the front bezel doors.
This protects the doors from potential damage during the move.

6. Extend the system completely out of the cabinet until the green locking latches snap into place and the slides lock into the fully extended position (FIGURE 3-7).

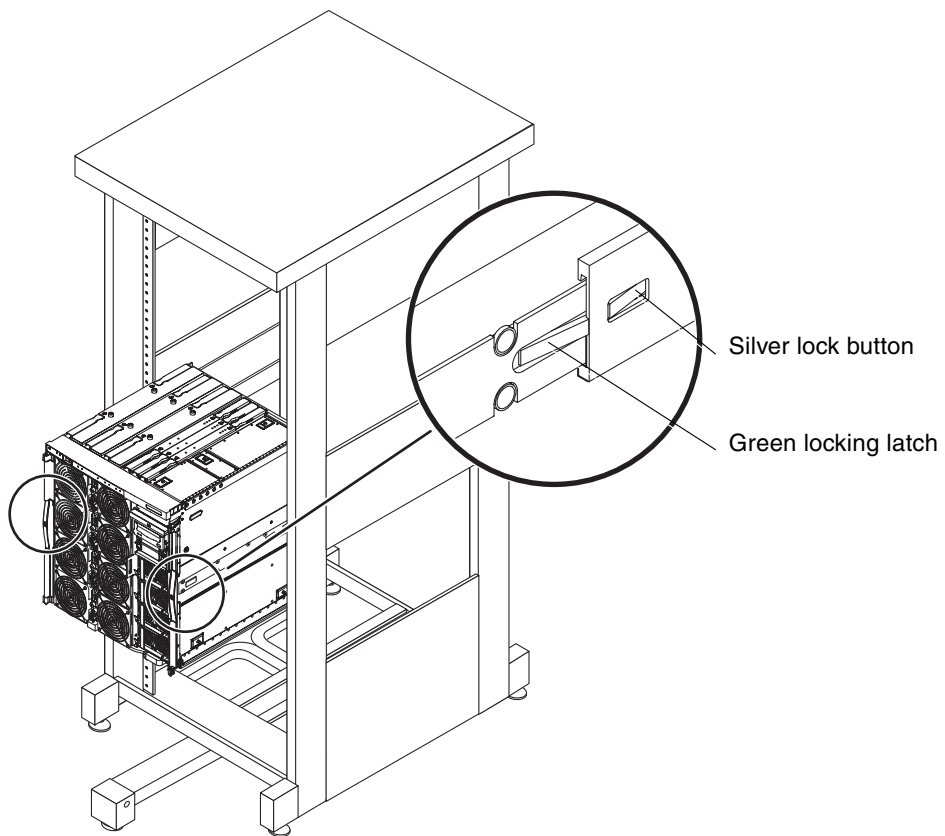

FIGURE 3-7 Sliding the System Out of the System Cabinet

Note – Use a mechanical lifting device. Insert the lifting device forks completely through the shipping cradle opening to provide maximum support.

7. **Raise the shipping cradle up to the system. Place the front of the shipping cradle toward the front of the system (FIGURE 3-8).**

This orientation allows the upper captive screws on the handles to align with the corresponding mounting holes on the system.

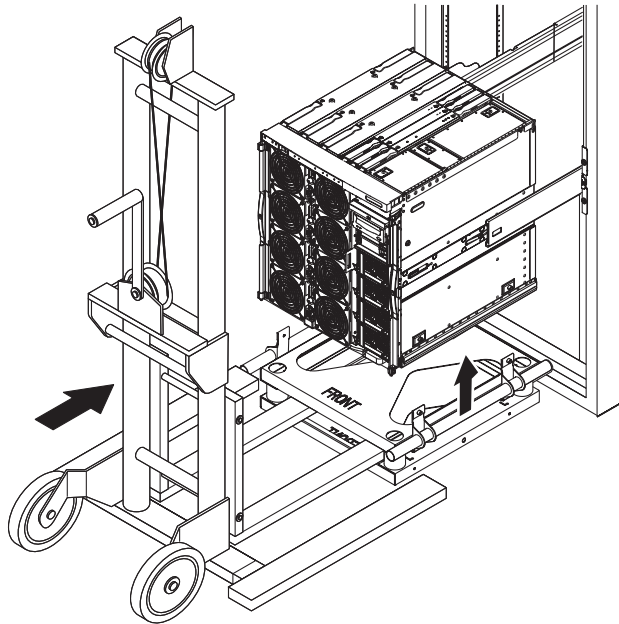

FIGURE 3-8 Lifting Device and Shipping Cradle

8. Slide the shipping cradle handles inward until they contact the sides of the system. Tighten all eight captive screws (FIGURE 3-9):
 - a. Secure the handle to the system with the upper four captive screws.
 - b. Secure the handle to the cradle base plate with the four lower captive screws.

Note – If necessary, reposition the system on the shipping cradle to align the captive screws with the corresponding holes.

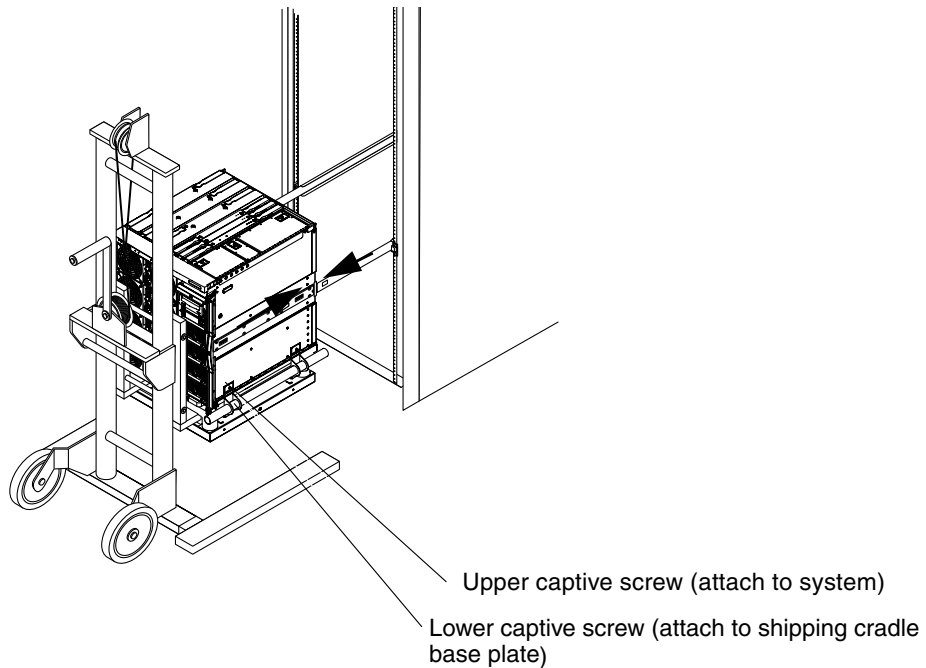

FIGURE 3-9 Securing the Captive Screws



Caution – Do not place the full weight of the system on the shipping cradle until all eight captive screws are secured.



Caution – Do not perform the following step until the weight of the system is fully supported. The system weighs 240 to 290 pounds (109 to 132 kg).

9. With the lifting device fully supporting the weight of the system, press the silver slide lock buttons (FIGURE 3-7) on the right and left slide assemblies. Pull the system away from the cabinet.

This action pulls the inner slides that are attached to the system out of the slide assemblies that are attached to the system cabinet (FIGURE 3-10).

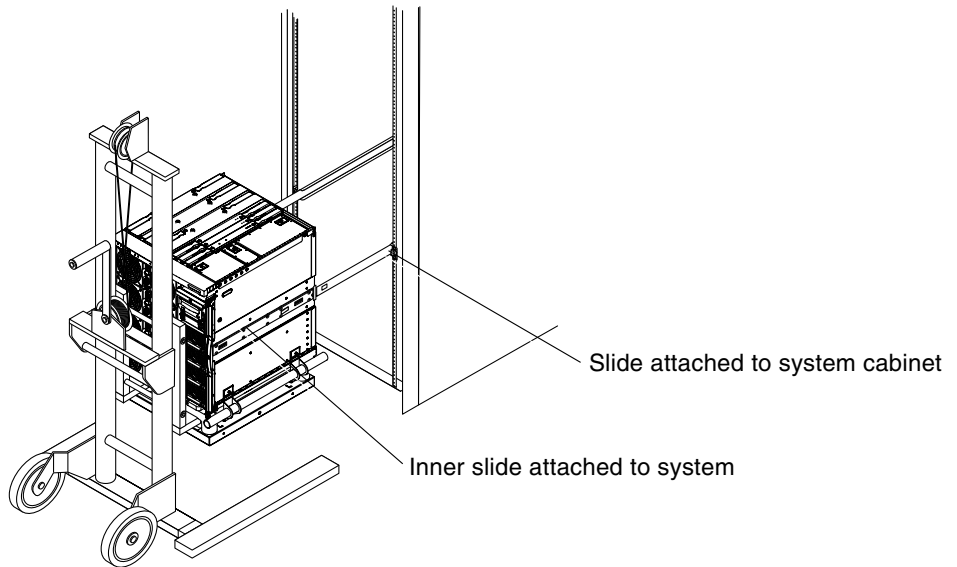

FIGURE 3-10 Detaching the Cabinet Slides From the System

3.3.1.2 Transporting the System

1. Complete [Step 1](#) through [Step 9](#) in [Section 3.3.1.1, "Securing the System on the Shipping Cradle"](#) on page 3-6.
2. If the new cabinet does not already have slides for this system, remove the slides from the old cabinet and install the slides to the new cabinet (FIGURE 3-10).
3. Extend the cabinet stabilizer of the new cabinet and lock it in position (FIGURE 3-1).



Caution – Failure to extend and lock the stabilizer bar before you slide a system out of the system cabinet can cause the system cabinet to tip over.

4. **Extend the outer slides from the cabinet and latch them in the extended position.**
5. **With the lifting device supporting the weight of the system, raise the system until it is level with the outer slides on the cabinet (FIGURE 3-9).**
6. **Carefully move the lifting device forward until the slides on the system are fully engaged with the outer slides on the cabinet (FIGURE 3-9).**
The latches on each side must click out, locking the slides.
7. **With the lifting device still supporting the weight of the system, loosen all eight captive screws (FIGURE 3-9):**
 - a. **Loosen the upper four captive screws that secure the handle to the system.**
 - b. **Loosen the lower four captive screws that secure the handle to the cradle base plate.**
8. **Pull both shipping cradle handles away from the system (FIGURE 3-5).**
This disconnects the shipping cradle from the system. Store the shipping cradle for future use.
9. **Press the green latches on each slide. Push the system into the cabinet (FIGURE 3-7).**
10. **Tighten the two captive screws on the front of the system (FIGURE 3-3).**
This secures the system in the cabinet.
11. **Retract the cabinet stabilization mechanism (FIGURE 3-1).**
12. **Reattach the cable management arm (if applicable).**
See Section 5.1, “CMA-Lite” on page 5-2 or Section 5.2, “CMA-800” on page 5-3.
13. **Reconnect all cabling. Use the cable management arm (if attached) to support and protect the cabling.**
14. **Reattach the front bezel doors to the system (if applicable).**

3.3.2 Transporting the System Cabinet With Installed Systems

If you have one or more systems installed in a system cabinet and you need to transport the entire system cabinet containing installed systems, you must install a retention washer and nut on the bolt at the rear of each slide rail before transporting the system cabinet (FIGURE 3-11).

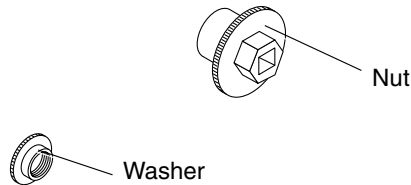

FIGURE 3-11 Retention Washer and Nut

1. Slide the system out of the system cabinet.
2. If a washer is installed on the rear of the slide rail, remove it.
3. From the rear of the system, insert and tighten the supplied retention washer onto the bolt (FIGURE 3-12).

The washer shoulder must face outwards.

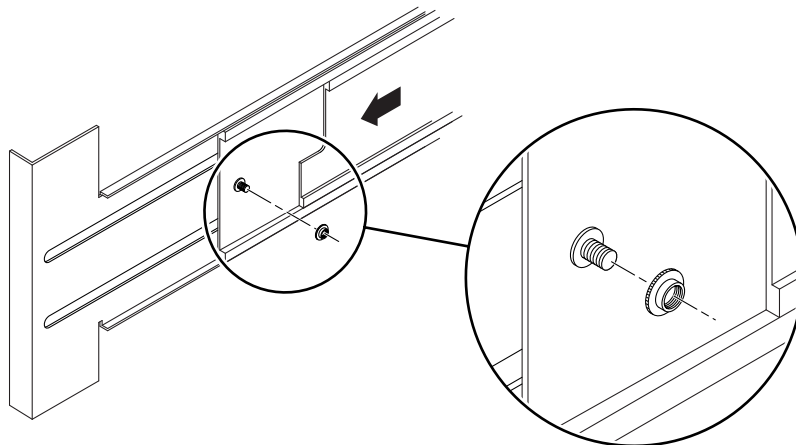

FIGURE 3-12 Inserting and Tightening the Retention Washer

4. Slide the system into the system cabinet.

5. From the rear of the system, insert and tighten the retention nut over the washer (FIGURE 3-13).

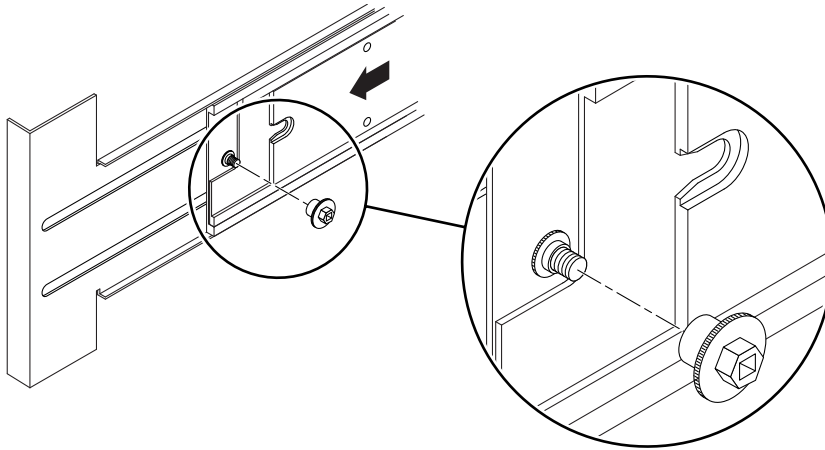

FIGURE 3-13 Inserting and Tightening the Retention Nut

6. Repeat **Step 1** through **Step 5** for the other side rail.
7. Repeat **Step 1** through **Step 6** for each system in the system cabinet.
It is now safe to transport the system cabinet with installed systems.

3.3.3 After Transporting the System Cabinet With Systems Installed

1. Make sure the system is in a location where it will not be moved for a while.
2. From the rear of the system, remove the retention nut over each washer (FIGURE 3-13).
3. Slide the system out of the system cabinet.
4. From the rear of the system, remove the threaded washer from each bolt, which is connected to the slide (FIGURE 3-12).
5. Repeat **Step 2** through **Step 4** for the other slide rail.
6. Repeat **Step 2** through **Step 5** for each system installed in the system cabinet.

Powering On and Off

This chapter explains how to power the system on and take the system to Standby mode. This chapter includes the following topics:

- Section 4.1, “Powering On the System” on page 4-1
- Section 4.2, “Taking the System to Standby Mode” on page 4-2
- Section 4.3, “Using the On/Standby Switch” on page 4-3

4.1 Powering On the System

1. **Make sure that a minimum of two power supplies are installed and powered on.**
 2. **Make sure that all power cables are connected and external circuit breakers are switched on.**
 3. **Power on the system from Standby mode with *one* of the following steps.**
 - Press and release the On/Standby switch to the right—On position.
- OR
- Type the `poweron` command at the `lom>` prompt.
Refer to the system administration manual and the system controller manual for this product.
4. **After a delay, which depends on the POST level set and the number of boards in the system, the following activities occur:**
 - The system active () LED is lit.
 - The system executes the power-on self-test (POST).

Then, the system is completely powered on.

4.2 Taking the System to Standby Mode

To take the system to Standby mode:

1. **Notify users that the system is going down.**
2. **Back up the system files and data to tape, if necessary.**
3. **Take the system to Standby mode by typing the `shutdown` command at the `lom>` prompt.**

Refer to the system administration manual. The following actions occur when the system is taken to Standby mode:

- The Solaris OS is cleanly shut down.
 - The system is powered off to Standby mode, which is the lowest level of operation.
 - The system controller and one fan remain running.
4. **Turn off each external drive and the expansion cabinet(s) (if any).**



Caution – Do not use the On/Standby switch to power off the system. Pressing the On/Standby switch longer than four seconds will abruptly terminate the Solaris OS. This method *is not* the recommended method to shut down the operating system. If you abruptly terminate the operating system, you may damage the file system.

4.2.1 Alternate Method to Halt the Solaris OS

Besides using the system controller `shutdown` command to halt the Solaris OS, you can also shut down the Solaris OS as a UNIX[®] superuser:

1. **Halt the Solaris OS as a UNIX superuser.**
Refer to the system administration manual.
2. **Wait for the system-halted message and the `ok>` prompt.**

4.3 Using the On/Standby Switch

The On/Standby switch is a rocker switch with two positions. [FIGURE 4-1](#) illustrates the location. [TABLE 4-1](#) describes how to use the On/Standby switch.

- On
- Standby

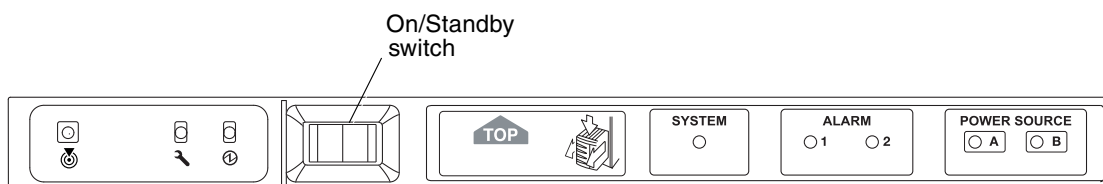



FIGURE 4-1 Sun Fire E2900 System On/Standby Switch

TABLE 4-1 On/Standby Switch Operation

On/Standby Switch Icons	On/Standby Switch Positions	Action	Description
	On	Press and release to power on the server.	This is the equivalent of the <code>poweron</code> command at the <code>lom></code> prompt.
	Standby (orderly shutdown)	<ul style="list-style-type: none"> • Press the On/Standby switch to the Standby position and hold for <i>less than</i> four seconds. This action shuts down the operating system in an orderly manner. 	<ul style="list-style-type: none"> • Solaris OS is halted and the system is taken to Standby mode. • Equivalent to issuing the <code>shutdown</code> command at the <code>lom></code> prompt. • Use in normal operation.
	Standby (forcible shutdown)	<ul style="list-style-type: none"> • Press the On/Standby switch to the Standby position and hold for <i>more than</i> four seconds. This action forcibly terminates the operating system. 	<ul style="list-style-type: none"> • Terminates the Solaris OS. Takes the system (or one or more FRUs) to Standby mode. • Equivalent to issuing the <code>poweroff</code> command at the <code>lom></code> prompt. • This process is not interruptible.



Caution – Pressing and holding the On/Standby switch to the Standby position for *more than* four seconds forcibly terminates the Solaris OS. This method of terminating the operating system *is not* the preferred method and can cause file system damage.

4.3.1 Preventing Accidental Operation of the On/Standby Switch

- **To disable the On/Standby switch, use the system controller `setupsc` command.**

This command prevents accidental operation of the On/Standby switch. Refer to the system controller manual.

Cable Management Arm

This chapter covers these topics:

- Section 5.1.1, “Removing the CMA-Lite” on page 5-2
- Section 5.1.2, “Installing the CMA-Lite” on page 5-3
- Section 5.2.1, “Removing the CMA-800” on page 5-3
- Section 5.2.2, “Installing the CMA-800” on page 5-4

The cable management arm (CMA) supports and protects cables when a system slides into or out of a cabinet. Systems can be configured with either of two cable management arm solutions: CMA-Lite and CMA-800. The CMA-Lite cable management arm solution is used if the larger CMA-800 management arm does not fit the cabinet. Threaded holes to attach the CMA are provided on the rear of the system (FIGURE 5-1).

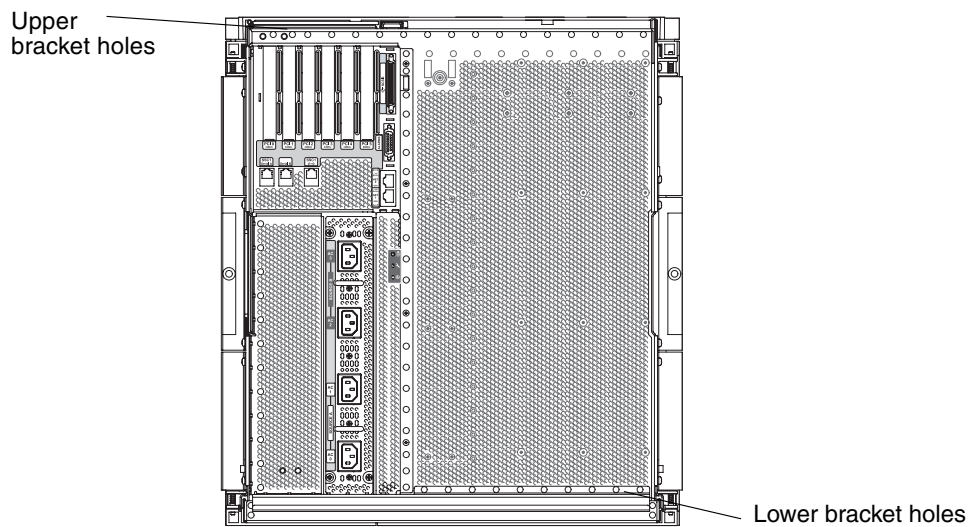

FIGURE 5-1 Bracket Mounting Holes

5.1 CMA-Lite

The following procedures describe how to remove and install the CMA-Lite cable management arm.

5.1.1 Removing the CMA-Lite

1. Loosen two captive screws (FIGURE 5-2) that secure:

- Pivot at the end of the lower arm to the bottom rear of the system.
- Center pivot point of the CMA to the inside rear of the left hand rail assembly.
- End of the upper arm to the top rear of the system.

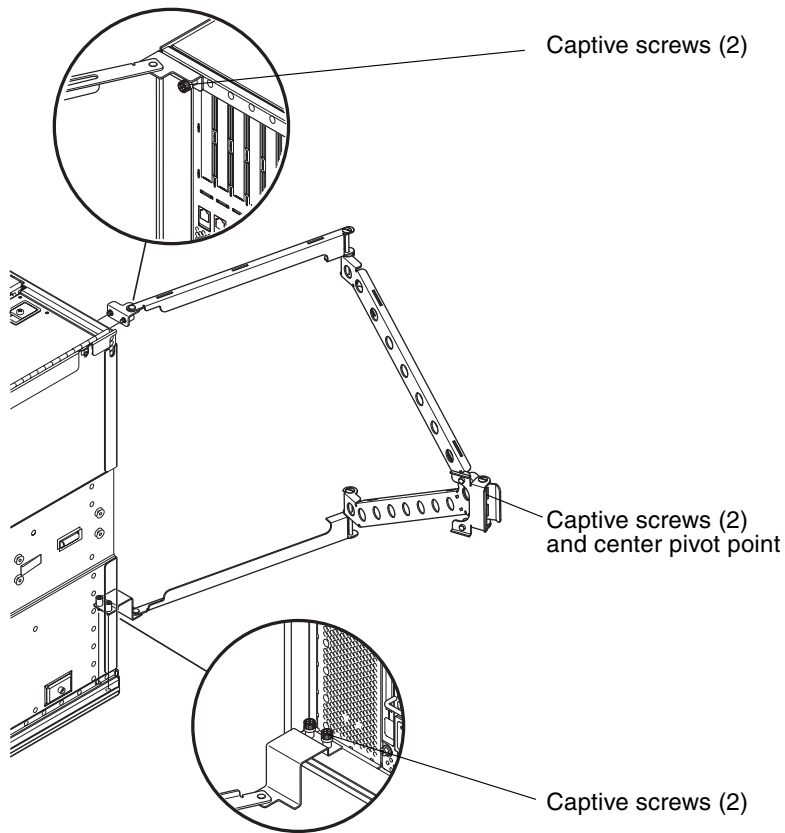

FIGURE 5-2 CMA-Lite Cable Management Arm

5.1.2 Installing the CMA-Lite

1. Secure the pivot at the end of the upper arm to the top rear of the system, using the two captive screws (FIGURE 5-2).
2. Secure the center pivot point of the CMA to the inside rear of the left hand rail assembly, using the two captive screws.
3. Secure the pivot at the end of the lower arm to the bottom rear of the system, using the two captive screws.

5.2 CMA-800

The following procedures describe how to remove and install the CMA-800.

5.2.1 Removing the CMA-800

1. Remove the hinge pin to the upper pivot bracket of the I/O cable arm.
2. Remove the hinge pin to the lower pivot bracket of the power cable arm (FIGURE 5-3).

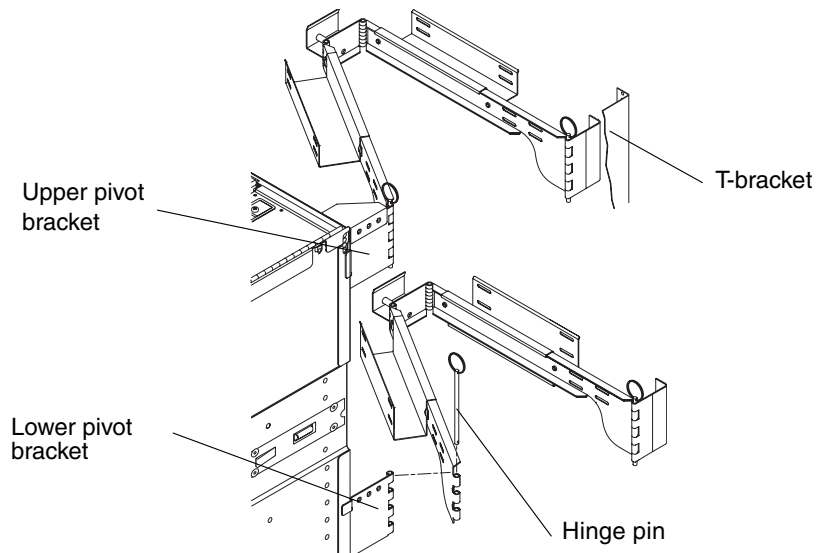

FIGURE 5-3 CMA-800

3. Loosen the two captive screws that secure the power cable arm to the bottom of the left T-bracket (FIGURE 5-3).
4. Loosen the two captive screws that secure the I/O cable arm to the top of the left T-bracket (FIGURE 5-3).
5. Loosen the two captive screws that secure the T-brackets to the right cabinet slide.
6. Loosen the two captive screws that secure the T-brackets to the left cabinet slide.
7. Loosen the two captive screws that secure the upper pivot bracket to the system.
8. Loosen the two captive screws that secure the lower pivot bracket (FIGURE 5-4).

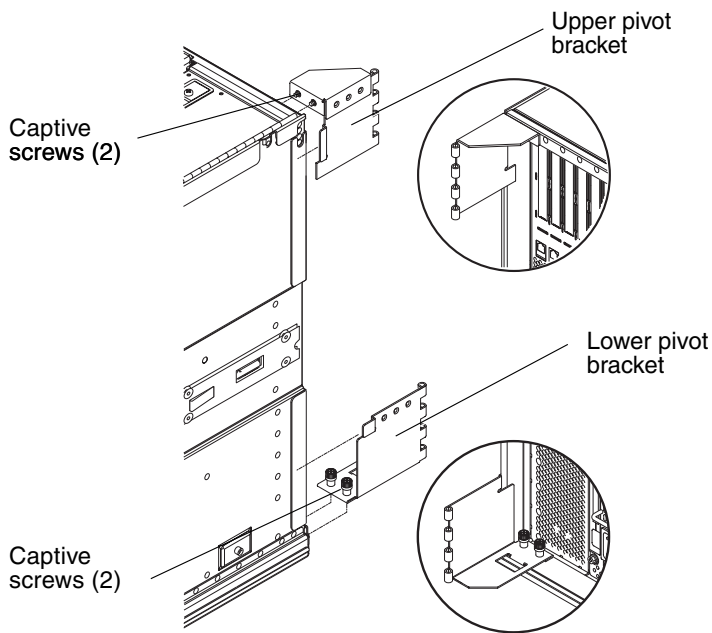

FIGURE 5-4 CMA-800 Upper and Lower Pivot Brackets

5.2.2 Installing the CMA-800

1. Remove the hinge pin to the upper pivot bracket of the I/O cable arm (FIGURE 5-3).
2. Remove the hinge pin from the lower pivot bracket of the power cable arm (FIGURE 5-3).
3. Secure the upper pivot bracket to the system with the two captive screws (FIGURE 5-4).

4. Secure the lower pivot bracket with the two captive screws (FIGURE 5-4).
5. Secure the T-brackets to the left and right cabinet slide. Use two captive screws for each slide (FIGURE 5-5).
The T-brackets are marked to indicate which bracket mounts on the right and left sides.
6. Secure the I/O cable arm to the top of the left T-bracket with the two captive screws.
7. Secure the power cable arm to the bottom of the left T-bracket with the two captive screws.

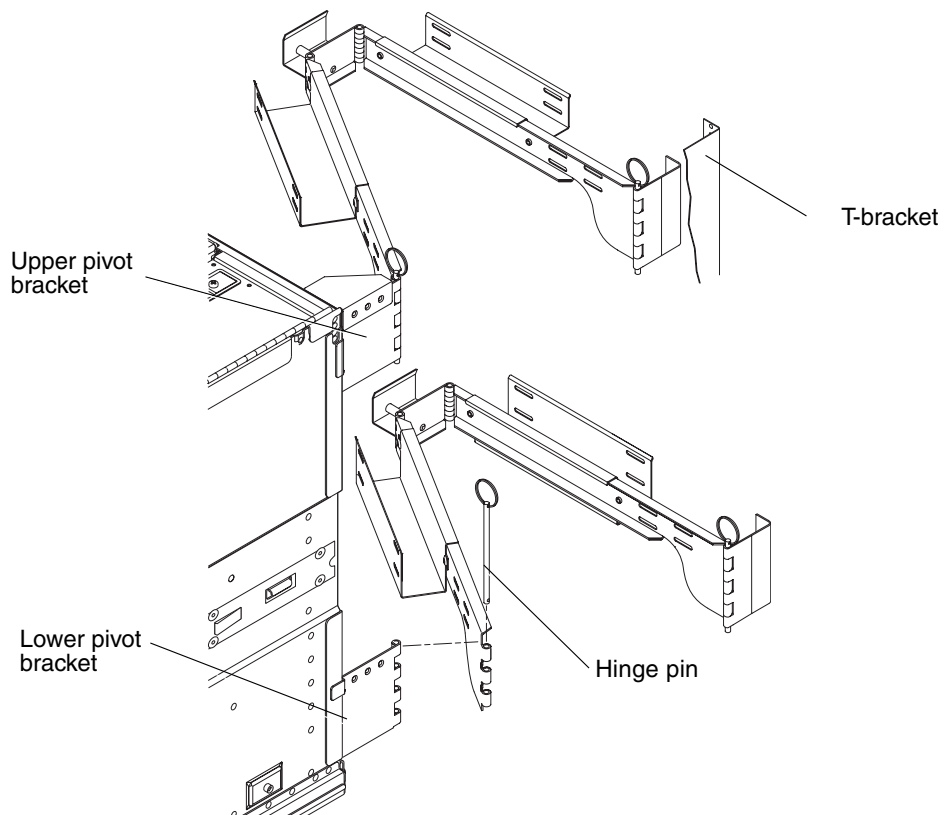

FIGURE 5-5 Upper and Lower Cable Arms and T-Bracket

8. Reconnect the I/O cable arm to the upper pivot bracket. Install the hinge pin to secure it (FIGURE 5-4 and FIGURE 5-5).
9. Reconnect the power cable arm to the lower pivot bracket. Install the hinge pin to secure it (FIGURE 5-4 and FIGURE 5-5).

Storage Devices

This chapter describes how to remove and install the removable media bay, tape drive, DVD drive, SCC reader, and hard disk drives. It contains the following topics:

- Section 6.1, “Hard Disk Drives” on page 6-1
- Section 6.2, “Removable Media Module” on page 6-5
- Section 6.3, “Tape Drive” on page 6-10
- Section 6.4, “DVD-ROM Drive” on page 6-14
- Section 6.5, “DVD-ROM Backplane” on page 6-16
- Section 6.6, “SCC Reader” on page 6-18

6.1 Hard Disk Drives

The two disk drives are located at the right front of the system ([FIGURE 6-1](#)).

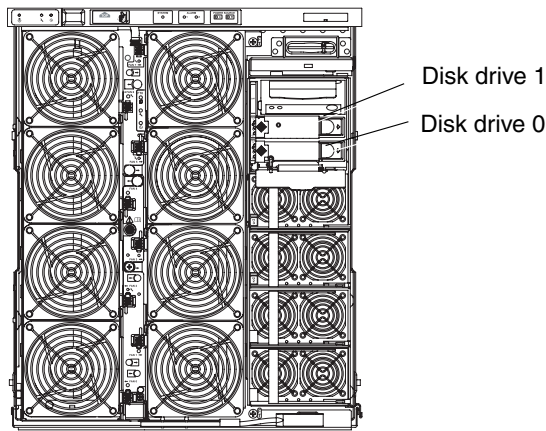





FIGURE 6-1 Location of the Hard Disk Drives

The disk drives have three LEDs (TABLE 6-1).

TABLE 6-1 Disk Drive LEDs

LED Name		On	Off
Activated (green)		Device is activated.	Device is deactivated.
Fault (amber)		Internal fault.	No internal fault.
OK to remove (blue or amber)		Device can be removed.	Device cannot be removed.



Caution – Use proper ESD grounding techniques when handling components. Wear an antistatic wrist strap and use an ESD-protected mat. Store ESD-sensitive components in its ESD safe packaging box before placing them on any surface.

You can remove and install the disk drives without powering off the system. To remove the removable media drives and bay, you must power off the system.

6.1.1 Removing a Hard Disk Drive

1. **Ensure the disk is backed up.**
2. **Unconfigure the disk drive using dynamic reconfiguration (DR).**
See the system administration manual.
3. **Ensure that the OK to remove () LED is lit.**
4. **Open the right front door of the system.**
5. **Attach a wrist strap. Place a grounded ESD mat close to the system.**
See [Section 2.8, “Antistatic Precautions”](#) on page 2-6.
6. **Lower the grill in front of the hard disk drives.**

7. Open the drive handle by pushing the latch to the right (FIGURE 6-2).

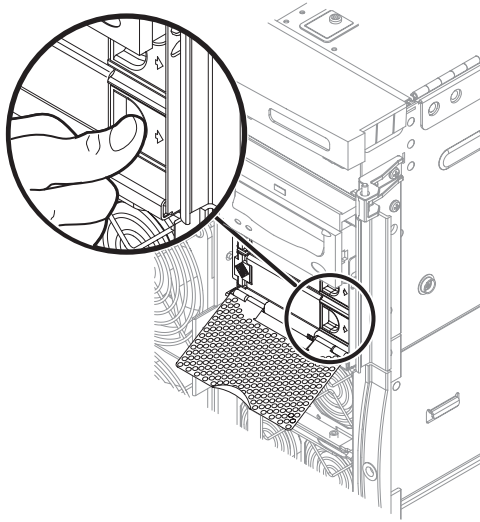

FIGURE 6-2 Releasing the Hard Disk Drive Ejector Handle

8. Extend the drive handle to disconnect the drive from the system (FIGURE 6-3).

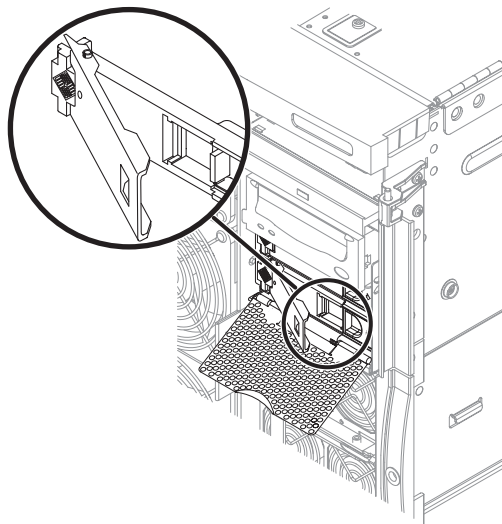

FIGURE 6-3 Ejecting the Hard Disk Drive

9. Remove the drive from the drive bay while holding the drive handle (FIGURE 6-4).
The hard disk drive rear connector is disconnected when the drive is ejected.

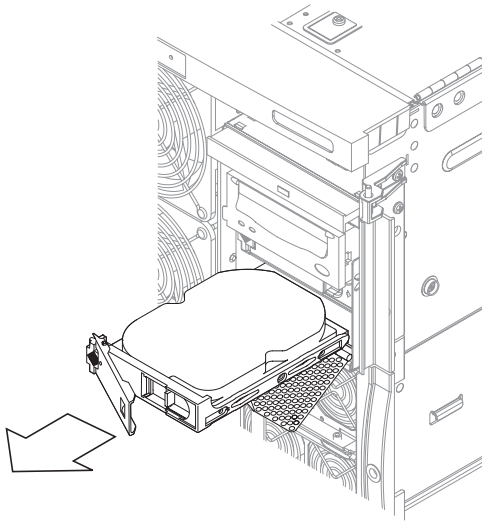



FIGURE 6-4 Removing the Hard Disk Drive

10. Place the drive on an ESD mat.
11. If required, replace the drive as described in [Section 6.1.2, “Installing a Hard Disk Drive”](#) on page 6-4.
12. Detach the antistatic wrist strap.
13. Close the front door of the system.
14. Reconfigure the disk drive, if necessary, by using DR.
Refer to the system administration manual.
15. Ensure that the OK to remove () LED is no longer lit.

6.1.2 Installing a Hard Disk Drive

1. Open the right front door of the system.
2. Attach a wrist strap. Place a grounded ESD mat close to the system.
See [Section 2.8, “Antistatic Precautions”](#) on page 2-6.
3. Lower the grill in front of the hard disk drives.

4. Insert the disk drive into the bay as far as it will go.
5. Close the drive handle to connect the drive to the system.
6. Detach the antistatic wrist strap.
7. Close the front door of the system.
8. Reconfigure the disk drive, if necessary, by using DR.
Refer to the system administration manual.
9. Ensure that the OK to remove (🔌) LED is no longer lit.

6.2 Removable Media Module



Caution – Use proper ESD grounding techniques when handling components. Wear an antistatic wrist strap and use an ESD-protected mat. Store ESD-sensitive components in its packaging box before placing them on any surface.



Caution – This procedure requires the system to be extended out of the system cabinet on its slides. Also, before attempting this procedure, you must extend the system cabinet stabilizer bar.

The removable media module is located at the front of the system (FIGURE 6-5). You do not need to remove the removable media module in order to remove and replace the tape drive and DVD-ROM drive. If the removable media module is defective, you must replace it.

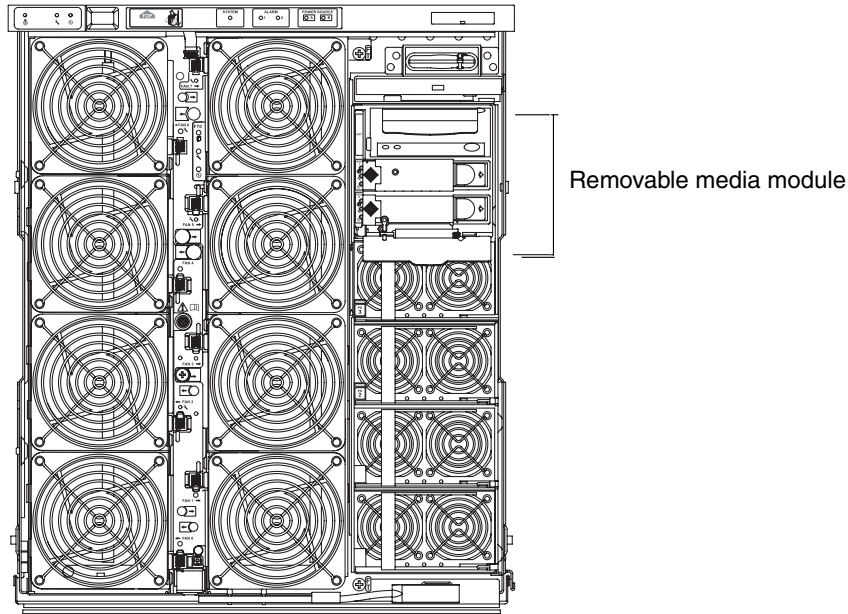

FIGURE 6-5 Removable Media Module Location—System Front View

6.2.1 Removing the Removable Media Module

1. Take the system to Standby mode.
See [“Taking the System to Standby Mode”](#) on page 4-2.
2. Remove power by removing the four input power cables, AC0 through AC4 ([FIGURE 1-3](#)).
3. Make sure that the leveling feet are extended to the floor.
4. Extend and lock the system cabinet stabilizer bar.



Caution – Failure to extend and lock the stabilizer bar before you slide a system out of the system cabinet can cause the system cabinet to tip over.

5. Slide the system out of the system cabinet until the locking latches click.
See [Section 3.1, “Sliding the System Out of the System Cabinet”](#) on page 3-1.
6. Open the front door.
7. Attach a wrist strap. Place a grounded ESD mat close to the system.
See [Section 2.8, “Antistatic Precautions”](#) on page 2-6.
8. Open the media bay access door. Loosen the latch screw (FIGURE 6-6). Release the latch and lift the cover.

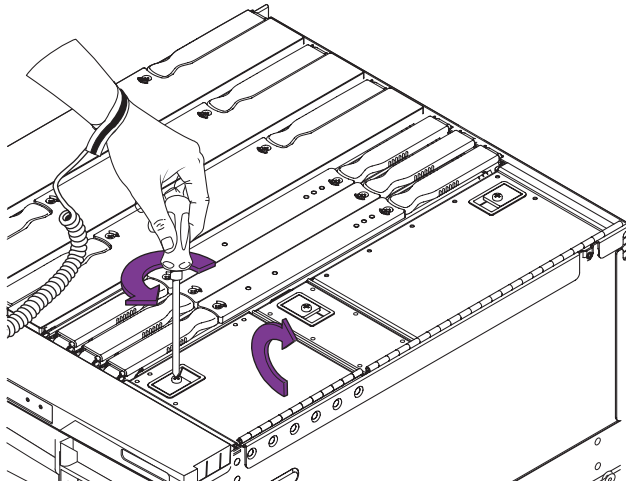

FIGURE 6-6 Opening the Media Bay Access Door

9. Disconnect the following cables from the IB_SSC assembly: disk drive power cable, SCSI data cable, SCC card reader cable, and DVD-ROM drive data/power cable (FIGURE 6-7).



Caution – Do not disconnect the SCC card reader cable end that connects to the SCC card reader or the SCSI data cable end that connects to the removable media backplane. Those cable ends are soldered and cannot be removed.

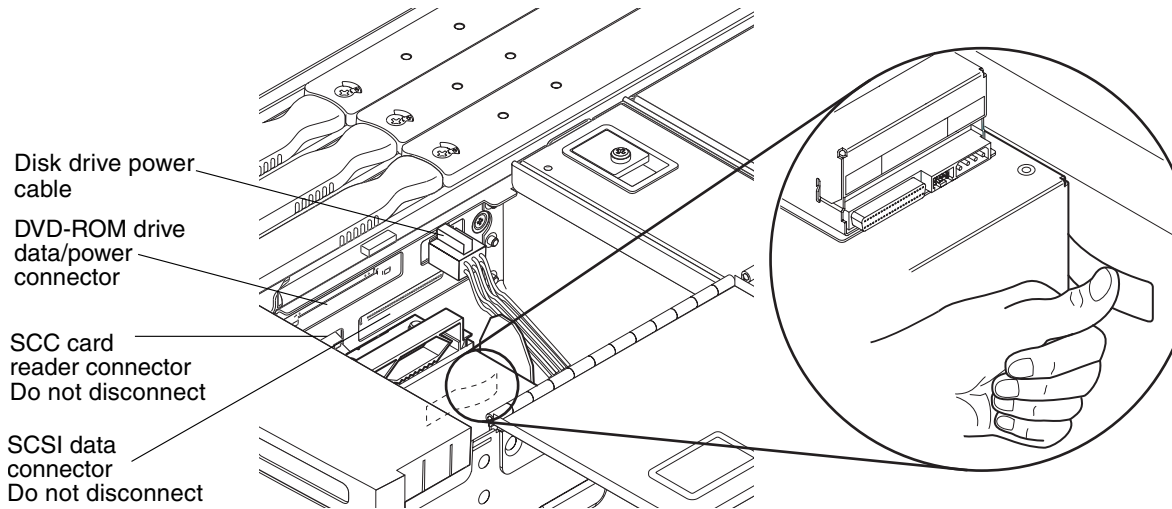

FIGURE 6-7 IB_SSC Assembly Cable and Connector Locations and the Removable Media Module Retaining Spring

10. Remove the foam air flow filter in front of the IB fan intake.
11. Locate the convex spring behind the right side of the removable media module. Press it in so it becomes concave (FIGURE 6-7).

12. Grasp the metal blade located at the front. Remove the removable media module a short distance from the system so that you can reach the connectors (FIGURE 6-8).

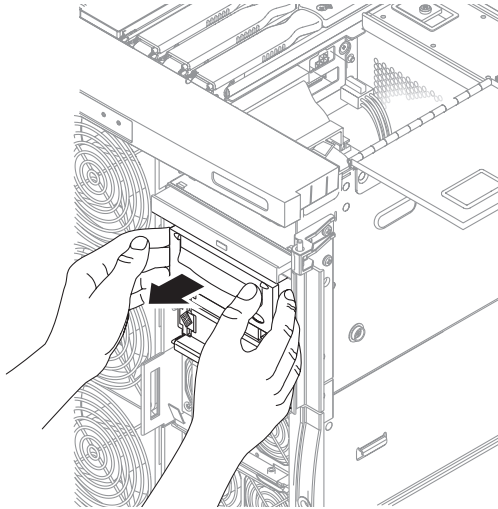

FIGURE 6-8 Sliding the Removable Media Module Out a Short Distance

13. Remove the removable media module. Make sure the connectors and cables do not catch on anything (FIGURE 6-9).

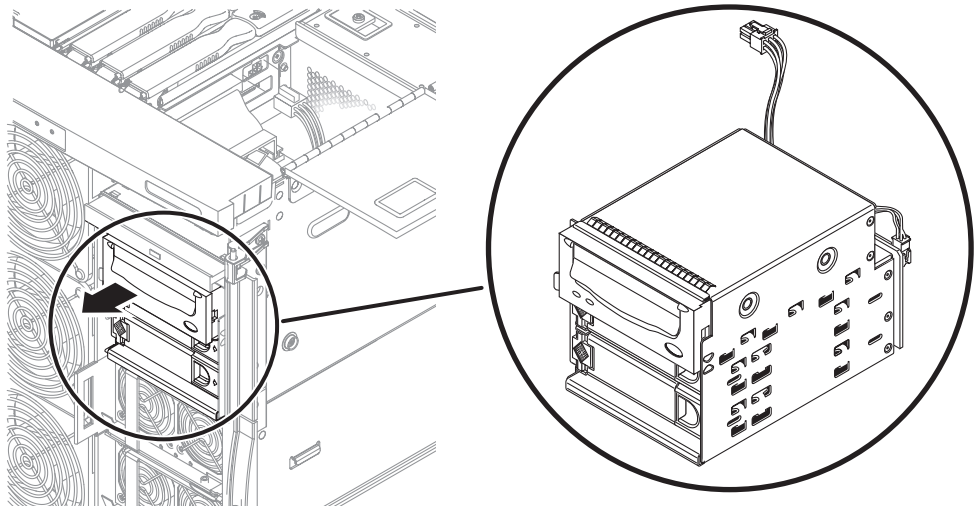

FIGURE 6-9 Removing the Removable Media Module

14. Place the removable media module on an ESD mat.

6.2.2 Installing the Removable Media Module

1. Complete [Step 1](#) through [Step 4](#) in [Section 6.2.1, “Removing the Removable Media Module”](#) on page 6-6.
2. Open the front right door of the system.
3. Insert the removable media module partially into the system ([FIGURE 6-8](#)).
4. Push the removable media module fully into the system until the metal tab engages.
5. Reconnect the disk drive power cable, SCSI data cable, SCC card reader cable, and DVD-ROM drive data/power cable to the IB_SSC assembly ([FIGURE 6-7](#)).
6. Remove the wrist strap.
7. Slide the system into the system cabinet and secure it.
See [Section 3.1, “Sliding the System Out of the System Cabinet”](#) on page 3-1.
8. Retract the system cabinet stabilization bar.
9. Reattach the power input cables, AC0 through AC4.
10. Power on the system.
See [Section 4.1, “Powering On the System”](#) on page 4-1, and refer to the system administration manual.

6.3 Tape Drive



Caution – Use proper ESD grounding techniques when handling components. Wear an antistatic wrist strap and use an ESD-protected mat. Store ESD-sensitive components in its ESD-safe packaging box before placing them on any surface.

Note – The tape drive has a SCSI ID of 5.

The tape drive is located in the removable media module, located at the right front of the system ([FIGURE 6-10](#)).

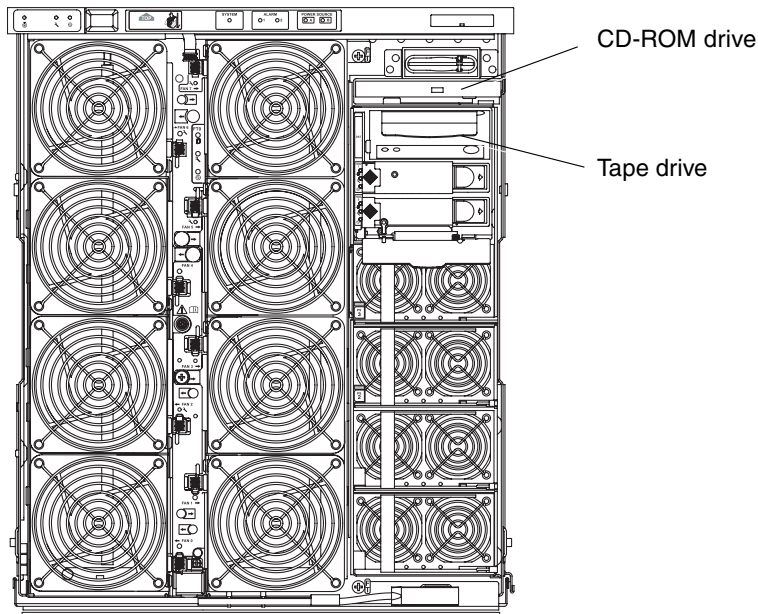

FIGURE 6-10 Tape Drive and DVD-ROM Drive Location—System Front View

6.3.1 Replacing an Existing Tape Drive

1. Take the system to Standby mode.
See [Section 4.2, “Taking the System to Standby Mode”](#) on page 4-2.
2. Open the right front door of the system.
3. Attach a wrist strap. Place a grounded ESD mat close to the system.
See [Section 2.8, “Antistatic Precautions”](#) on page 2-6.
4. Hold the metal tab located on the left of the tape drive. Remove the tape drive.
5. Place the tape drive on an ESD mat.
6. If you are not installing a replacement tape drive at this time, install a filler panel.
7. Remove the four screws securing the baseplate to the drive you removed. Remove the baseplate ([FIGURE 6-11](#)).

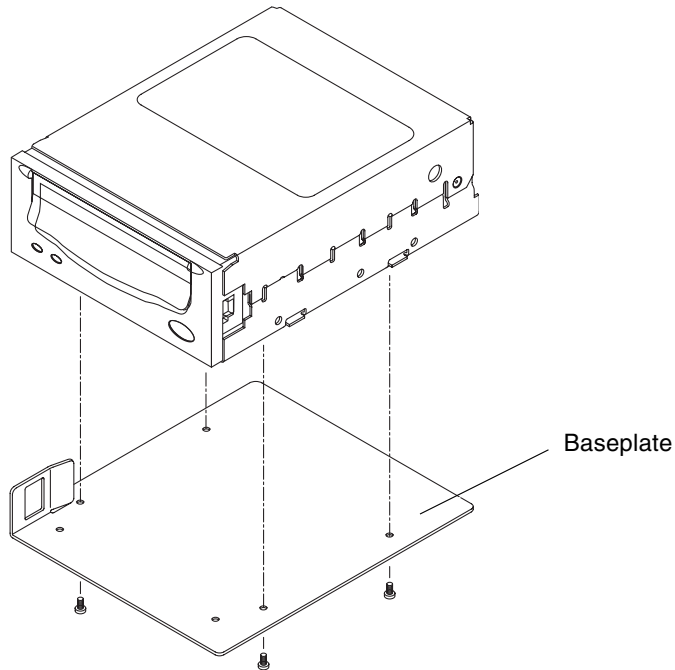

FIGURE 6-11 Removing or Attaching the Baseplate to the Tape Drive

8. Attach the baseplate to the new tape drive. Use the four countersunk screws shipped with the drive (FIGURE 6-11).
9. Install the new drive. Insert it into the system until the metal latch on the left side engages.

6.3.2 Installing a New Tape Drive

1. Take the system to Standby mode.
See [Section 4.2, "Taking the System to Standby Mode"](#) on page 4-2.
2. Open the right front door of the system.
3. Attach a wrist strap. Place a grounded ESD mat close to the system.
See [Section 2.8, "Antistatic Precautions"](#) on page 2-6.
4. Pull the tape drive filler panel forward to remove it.
5. Remove the two countersunk screws that secure the tape drive filler panel to the baseplate (FIGURE 6-12). Remove the tape drive filler panel.

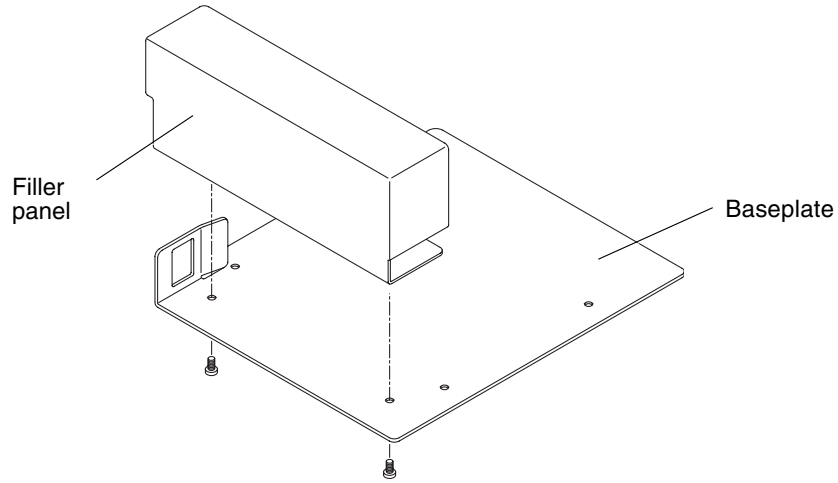

FIGURE 6-12 Dismantling the Tape Drive Filler Panel

6. Line up the baseplate of the tape drive filler panel with the tape drive. Attach the baseplate to the tape drive. Use the four countersunk screws shipped with the drive (FIGURE 6-11).
7. Install the new drive. Insert it into the system until the metal latch on the left side engages (FIGURE 6-13).

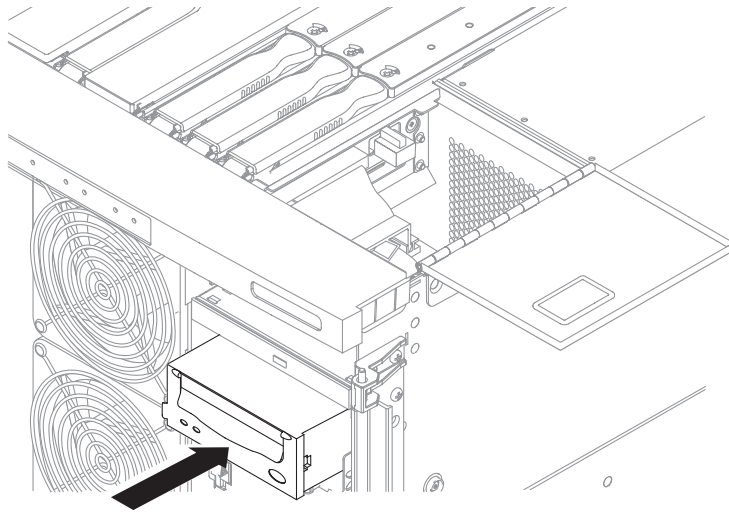

FIGURE 6-13 Inserting a Tape Drive Into the System

8. Detach the antistatic wrist strap.

9. Close the front door of the system.

10. Power on the system.

See [Section 4.1, “Powering On the System”](#) on page 4-1, and refer to the system administration manual.

6.4 DVD-ROM Drive



Caution – Use proper ESD grounding techniques when handling components. Wear an antistatic wrist strap and use an ESD-protected mat. Store ESD-sensitive components in its ESD-safe packaging box before placing them on any surface.

The DVD-ROM drive is located at the right front of the system ([FIGURE 6-10](#)).

6.4.1 Replacing the DVD-ROM Drive

1. Take the system to Standby mode.

See [Section 4.2, “Taking the System to Standby Mode”](#) on page 4-2.

2. Open the right front door of the system.

3. Attach a wrist strap. Place a grounded ESD mat close to the system.

See [Section 2.8, “Antistatic Precautions”](#) on page 2-6.

4. Open the media bay access door at the top of the system. Loosen the latch securing screw. Lift the latch and raise the cover ([FIGURE 6-14](#)).

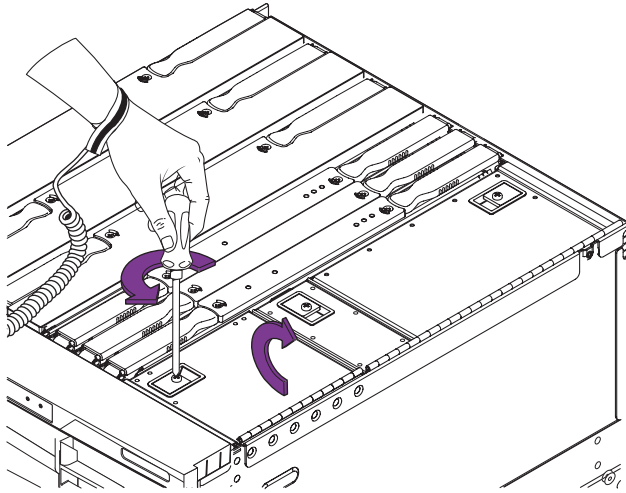

FIGURE 6-14 Opening the Media Bay Access Door—System Top View

5. Inside the media bay, push the metal latch to the right (**FIGURE 6-15**). The latch retains the drive.

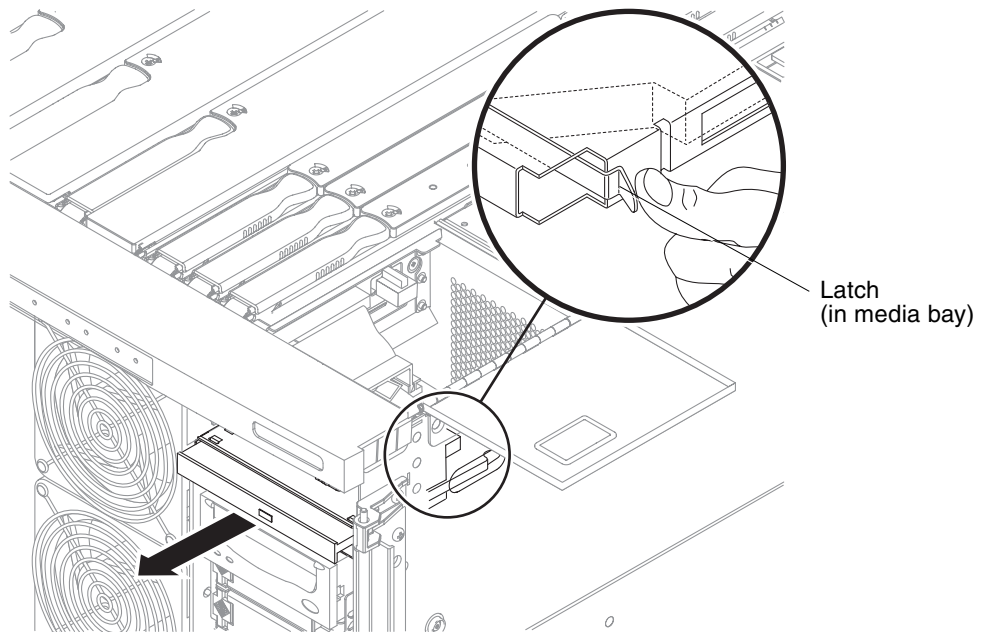

FIGURE 6-15 Removing the DVD-ROM Drive

6. Disconnect the DVD-ROM drive from the backplane connector. Firmly pull the DVD-ROM drive from the front of the system (FIGURE 6-15).
7. Place the drive on an ESD mat.
8. If required, install a replacement DVD-ROM drive. Insert the DVD-ROM drive into the system until the latch engages.
9. Close the media bay access door and tighten the latch securing screw.
10. Detach the antistatic wrist strap.
11. Close the front door of the system.

6.5 DVD-ROM Backplane



Caution – Use proper ESD grounding techniques when handling components. Wear an antistatic wrist strap and use an ESD-protected mat. Store ESD-sensitive components in its ESD-safe packaging box before placing them on any surface.



Caution – This procedure requires the system to be extended out of the system on its slides. You must extend the system cabinet stabilizer bar.

6.5.1 Replacing the DVD-ROM Backplane

1. Complete [Step 1](#) to [Step 6](#) in [Section 6.4.1, “Replacing the DVD-ROM Drive” on page 6-14](#).
2. Open the media bay access door at the top of the system ([FIGURE 6-14](#)).
3. Disconnect the DVD-ROM drive data/power cable from the IB_SSC board and from the DVD-ROM drive ([FIGURE 6-16](#)).



Caution – Do not disconnect the SCSI data cable end that connects the removable media backplane. That cable end is soldered and cannot be removed.

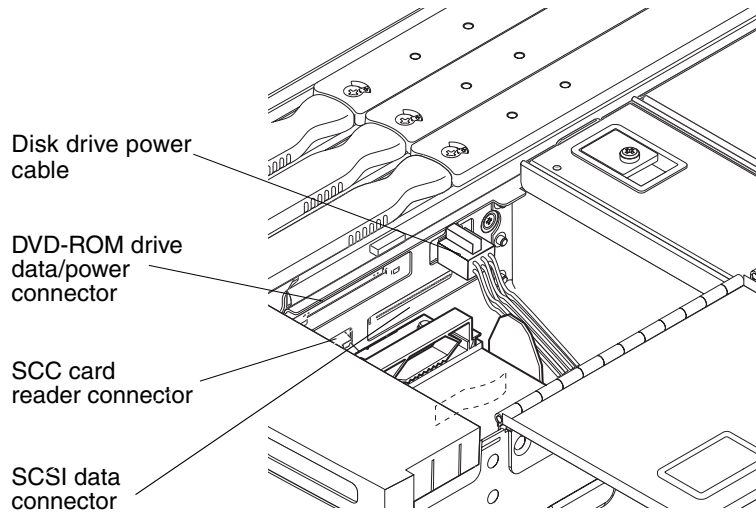

FIGURE 6-16 IB_SSC Assembly Cable and Connector Locations

4. Remove the DVD-ROM backplane, which is the small board located at the back of the DVD-ROM drive ([FIGURE 6-17](#)).

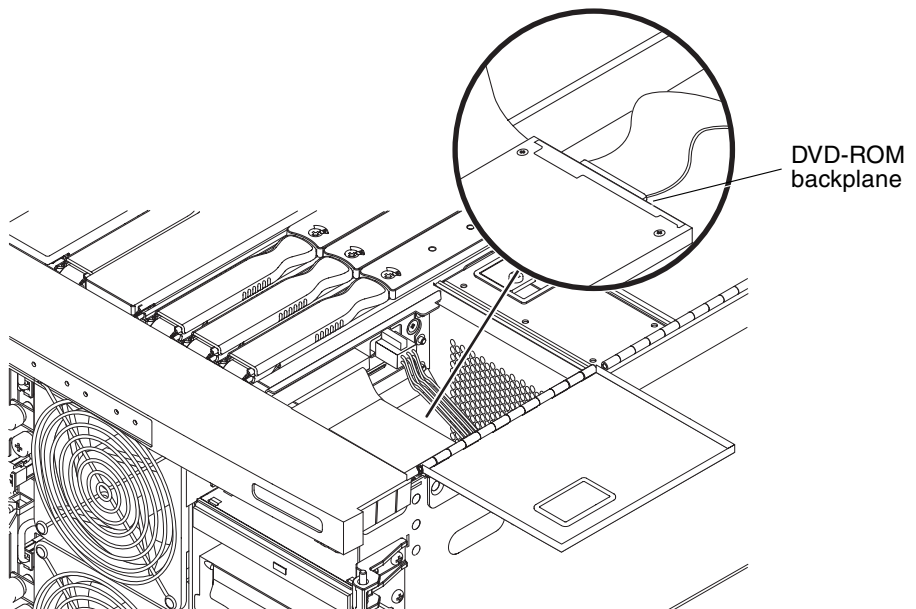

FIGURE 6-17 DVD-ROM Backplane

5. Install the replacement backplane to the DVD-ROM drive.
6. Reconnect the DVD-ROM drive data/power cable to the IB_SSC board and to the DVD-ROM drive (FIGURE 6-16).
7. Insert the DVD-ROM drive into the chassis until the latch engages.
8. Close the media bay access door and tighten the latch securing screw.
9. Detach the antistatic wrist strap.
10. Close the front door of the system.

6.6 SCC Reader



Caution – Use proper ESD grounding techniques when handling components. Wear an antistatic wrist strap and use an ESD-protected mat. Store ESD-sensitive components in its ESD safe packaging box before placing them on any surface.



Caution – This procedure requires the system to be extended out of the system cabinet on its slides. You must extend the system cabinet stabilizer bar.

To remove or replace the SSC reader (FIGURE 6-18) you must open the media bay access door at the top of the system (FIGURE 6-14).

6.6.1 Removing the SCC Reader

1. Take the system to Standby mode.
See “Taking the System to Standby Mode” on page 4-2.
2. Remove the four input power cables, AC0 through AC4 (FIGURE 1-3).
3. Make sure that the leveling feet are extended to the floor.
4. Extend and lock the system cabinet stabilizer bar.
5. Slide the system out of the system cabinet until the locking latches click.
See Section 3.1, “Sliding the System Out of the System Cabinet” on page 3-1.

6. **Attach a wrist strap. Place a grounded ESD mat close to the system.**
See [Section 2.8, “Antistatic Precautions”](#) on page 2-6.
7. **Remove the system configuration card (SCC).**
This card is the size of a credit card, and is located above the CD-ROM drive ([FIGURE 6-18](#)).

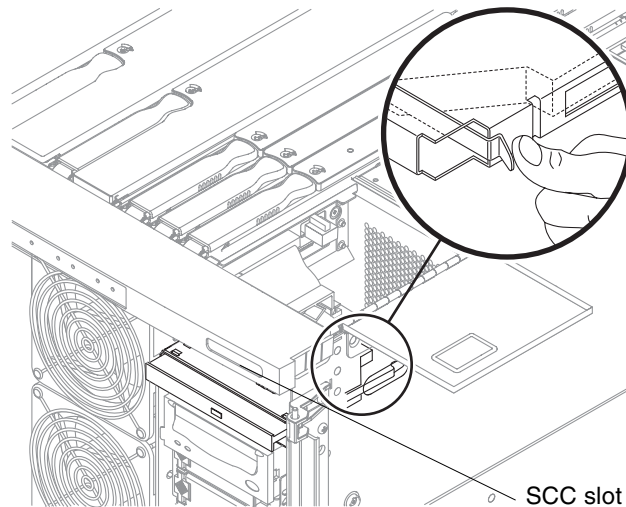

FIGURE 6-18 System Configuration Card Slot Location

8. **Open the media bay access door. Loosen the latch securing screw. Release the latch and lift the cover ([FIGURE 6-14](#)).**
9. **Disconnect the SCC reader cable from the IB_SSC board ([FIGURE 6-19](#)).**



Caution – Do not disconnect the SCC reader cable from the SCC card reader. The cable end that is attached to the SCC card reader *cannot* be removed.

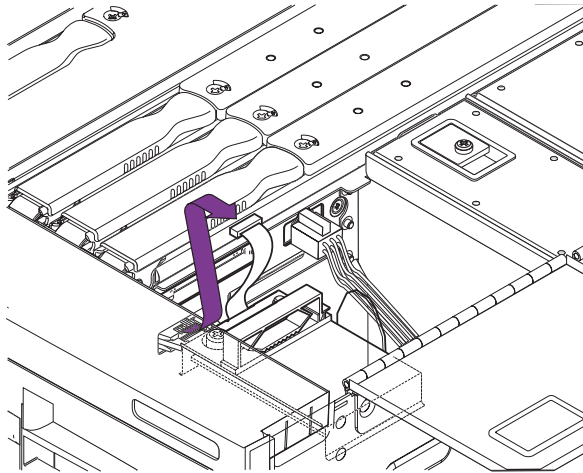

FIGURE 6-19 Disconnecting the SCC Reader Cable

10. Loosen the captive screw securing the SCC reader ([FIGURE 6-20](#)).

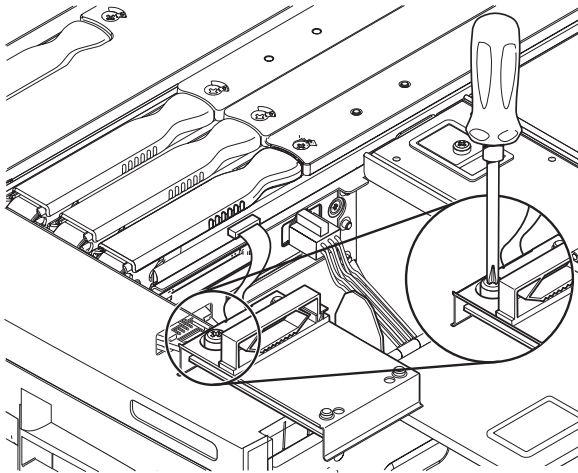

FIGURE 6-20 Loosening the SCC Reader Captive Screw

11. Lift the reader off the locating pins (FIGURE 6-21). Place it on an ESD mat.

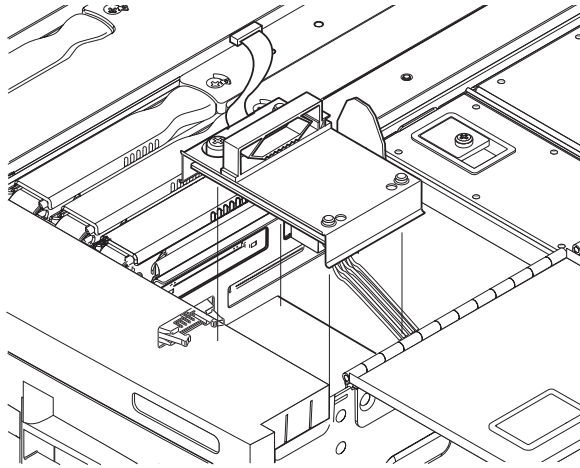

FIGURE 6-21 Removing the SCC Reader

6.6.2 Installing the SCC Reader

1. Complete [Step 1](#) through [Step 6](#) in [Section 6.6.1, “Removing the SCC Reader”](#) on [page 6-18](#).
2. Open the media bay access door and loosen the latch securing screw. Release the latch and lift the cover ([FIGURE 6-14](#)).
3. Connect the SCC reader cable ([FIGURE 6-19](#)) to the IB_SSC board.
4. Place the reader over the locating pins. Press firmly to seat it ([FIGURE 6-21](#)).
5. Tighten the captive screw ([FIGURE 6-20](#)).
6. Close and latch the media bay access door.
7. Remove the wrist strap.
8. Slide the system into the system cabinet and secure it.
See [Section 3.1, “Sliding the System Out of the System Cabinet”](#) on [page 3-1](#).

9. Retract the system cabinet stabilizer bar.
10. Reattach the four power input cables, AC0 through AC4.
11. Power on the system.
See [Section 4.1, "Powering On the System"](#) on page 4-1 and refer to the system administration manual.

Cooling Subsystem

This chapter describes how to remove and install the main system fans, the fan tray, and the IB fans.

You can replace individual fans without powering off the system. To replace the main fan tray, you must take the system to Standby mode and remove power from the system.

This chapter contains the following topics:

- [Section 7.1, “Main Fans” on page 7-2](#)
 - [Section 7.1.1, “Fan Failures” on page 7-2](#)
 - [Section 7.1.2, “Removing a Main Fan” on page 7-4](#)
 - [Section 7.1.3, “Installing a Main Fan” on page 7-6](#)
- [Section 7.2, “Main Fan Tray” on page 7-7](#)
 - [Section 7.2.1, “Removing the Main Fan Tray” on page 7-7](#)
 - [Section 7.2.2, “Installing the Main Fan Tray” on page 7-10](#)
- [Section 7.3, “IB Fans” on page 7-11](#)
 - [Section 7.3.1, “Removing an IB Fan” on page 7-12](#)
 - [Section 7.3.2, “Installing an IB Fan” on page 7-14](#)

7.1 Main Fans

7.1.1 Fan Failures

Failure of main fans 6 and 7 can cause reduced system availability. In all procedures observe these cautions:



Caution – Use proper ESD grounding techniques when handling components. Wear an antistatic wrist strap and use an ESD-protected mat. Store ESD-sensitive components in its ESD safe packaging box before placing them on any surface.



Caution – Do not operate for extended periods with a fan removed. Doing so may cause system shutdown.

Each of the eight main fans has one fault () LED. The fault LED is lit when there is a fan fault or failure. The fault LED is off when there is no fault. [TABLE 7-1](#), [TABLE 7-2](#) and [TABLE 7-3](#) list fan problems or failures, what steps to take, and what the system reports.

TABLE 7-1 Fan Failure Procedures—One CPU/Memory Board (4 CPUs) Configuration

Problem	Resolution	System Availability
If the system is operating at up to 35 degrees C ambient temperature:		
One or more main fans has slowed or stopped.	Hot-swap the fan.	No impact.
If the system is operating between 35 to 40 degrees C ambient temperature:		
Main fan 0 through 6 is running slow or stopped.	Hot-swap the fan.	System reports alarms but continues to operate. No impact on system availability.
Main fan 7 is running slow.	Replace the faulty fan. Consider replacing the entire fan tray as a preventive maintenance action.	System reports alarms but continues to operate. No impact on system availability.
Main fan 7 has stopped.	Replace the faulty fan. You can hot-swap the fan if CPU/Memory board SB0 (CPU processor 2) has been disabled.	System reports alarms but continues to operate. No impact on system availability.

TABLE 7-2 Fan Failure Procedures—Two CPU/Memory Boards (8 CPUs) Configuration

Problem	Resolution	System Availability
If the system is operating up to 35 degrees C or between 35 to 40 degrees C ambient temperature:		
Main fan 0 through 5 or system fan 7 is running slow or stopped.	Hot-swap the fan.	System reports alarms but continues to operate. No impact on system availability.
Main fan 6 is running slow.	Replace the faulty fan. Consider replacing the entire fan tray as a preventive maintenance action.	System reports alarms but continues to operate. No impact on system availability.
Main fan 6 has stopped.	Replace the faulty fan. You can hot-swap the fan if CPU/Memory board SB0 (CPU processor 2) has been disabled.	System will reboot within nine minutes with CPU/Memory board SB2 (CPU processor 2) disabled.

TABLE 7-3 Fan Failure Procedures—Three CPU/Memory Boards (12 CPUs) Configuration

Problem	Resolution	System Availability
If the system is operating up to 35 degrees C or between 35 to 40 degrees C ambient temperature:		
Main fan 0 through 5 or system fan 7 is running slow or stopped.	Hot-swap the fan.	No impact.
Main fan 6 is running slow.	Replace the faulty fan. Consider replacing the entire fan tray as a preventive maintenance action.	System reports alarms but continues to operate. No impact on system availability.
Main fan 6 has stopped.	Replace the faulty fan. You can hot-swap the fan if CPU/Memory board SB2 (CPU processor 2) and SB4 (CPU processor 2) have been disabled.	System will reboot within seven minutes with CPU/Memory board SB4 (CPU processor 2) and CPU/Memory board SB2 (CPU processor 2) disabled.

7.1.2 Removing a Main Fan

1. Open the front doors to the system.
2. Attach the wrist strap.
See [Section 2.8, “Antistatic Precautions”](#) on page 2-6.
3. Identify the fan that is faulty and needs to be replaced.

The fault () LED on the panel between the two columns of fans should be lit.

4. Identify the fan’s power connector and captive retaining screw.
5. Disconnect the power connector ([FIGURE 7-1](#)).



Caution – Wait at least ten seconds before proceeding with the next step. This allows the fan to stop spinning.

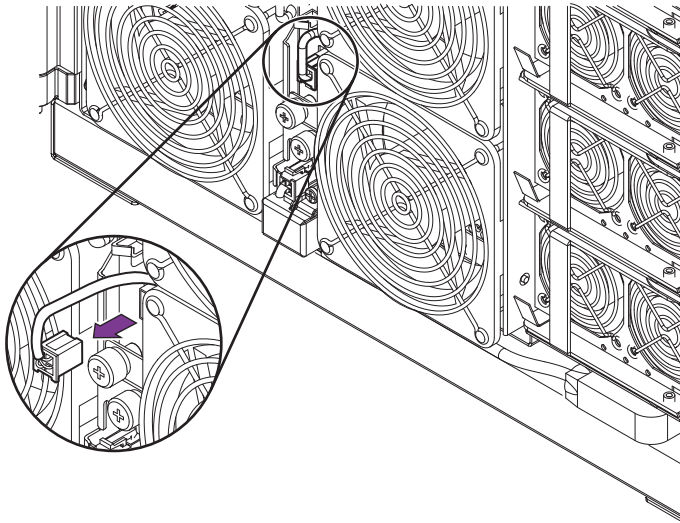

FIGURE 7-1 Disconnecting the Fan Power Connector

6. Loosen the appropriate captive screw that secures the fan ([FIGURE 7-2](#)).



Caution – There is no finger guard on the reverse side of the fan. Take care and hold the fan only by the sides of the assembly.

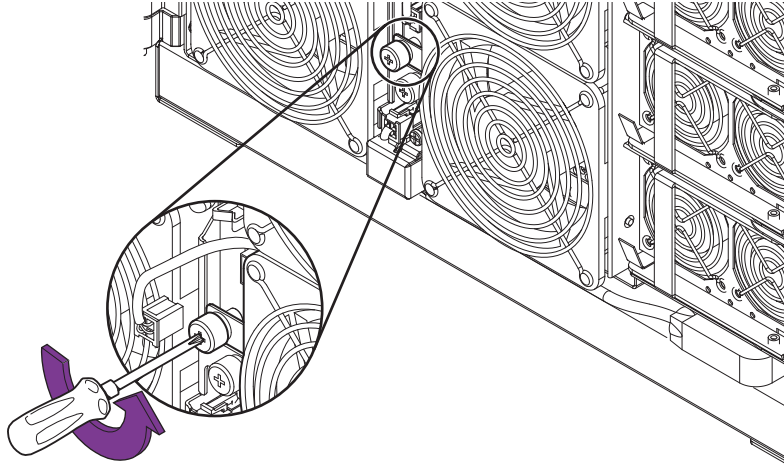

FIGURE 7-2 Loosening the Fan's Captive Screw

7. Remove the fan and place on an ESD mat (FIGURE 7-3).

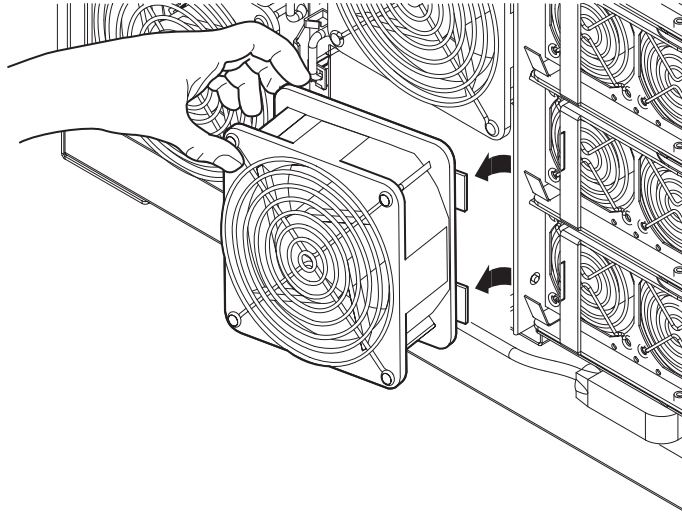

FIGURE 7-3 Removing a Fan

7.1.3 Installing a Main Fan

1. Open the front doors of the system.
2. Attach a wrist strap.
See [Section 2.8, “Antistatic Precautions”](#) on page 2-6.
3. Orient the fan so that the two lugs on the metal carrier engage in the cutouts in the fan tray ([FIGURE 7-4](#)).

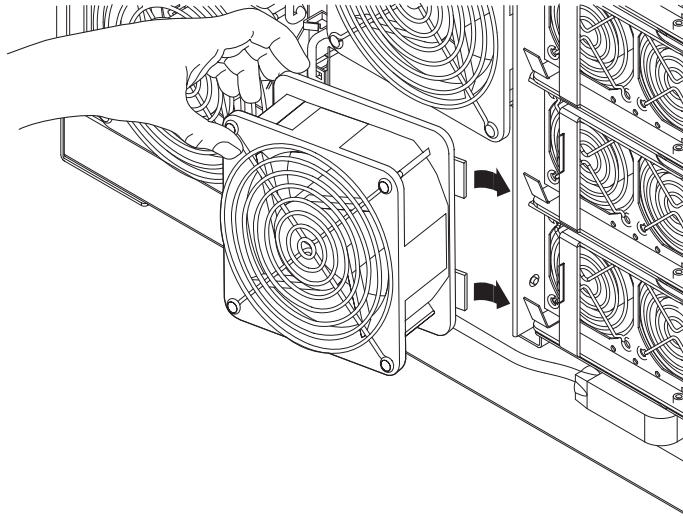



FIGURE 7-4 Inserting a Fan Into the Fan Tray

4. Tighten the captive screw to secure the fan ([FIGURE 7-2](#)).
 5. Replace the power connector to the fan ([FIGURE 7-1](#)).
- If the system is powered on, the fault LED  will not be lit.

Note – If a fan failed and the system has shut down to Standby, the fault LED will not be extinguished until you power on the system.



Caution – If the system is powered on, or the newly installed fan is fan 3, the fan starts immediately after you insert the fan and attach the power connector.

7.2 Main Fan Tray



Caution – The fan tray is not hot-pluggable. Attempting to hot-plug the fan tray while the system is powered on may result in damage. When an overtemperature is detected, the system shuts down.



Caution – Use proper ESD grounding techniques when handling components. Wear an antistatic wrist strap and use an ESD-protected mat. Store ESD-sensitive components in its ESD safe packaging box before placing them on any surface.

The main fan tray has three LEDs: power, fault, and removal OK. The LEDs are located on the panel between the two columns of fans. [TABLE 7-4](#) lists the main fan tray LED functions.

TABLE 7-4 Main Fan Tray LED Functions

LED Name		On	Off
Activated LED (green)		Device is activated.	Device is deactivated.
Fault LED (amber)		Internal fault or failure.	No internal fault or failure.
OK to remove (blue or amber)		Fan assembly can be removed.	Fan assembly cannot be removed.

7.2.1 Removing the Main Fan Tray

1. Take the system to Standby mode.

See [Section 4.2, “Taking the System to Standby Mode”](#) on page 4-2.

2. Remove power to the system by removing the four input power cables, AC0 through AC4 ([FIGURE 1-3](#)).

3. Open the front doors of the system.

4. Attach a wrist strap. Place a grounded ESD mat close to the system.

See [Section 2.8, “Antistatic Precautions”](#) on page 2-6.

5. Unlatch and disconnect the fan tray power connector ([FIGURE 7-5](#)).

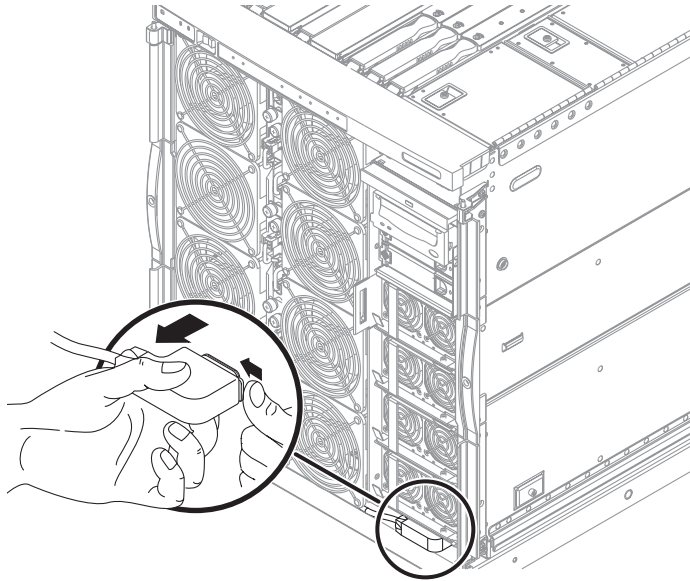

FIGURE 7-5 Removing the Fan Tray Power Connector

6. Remove the system indicator board connector retaining clip and disconnect the connector.

See [Section 12.1.1, "Removing the System Indicator Board"](#) on page 12-2.

7. Loosen the two captive screws to the fan tray in the following order (FIGURE 7-6). There is one captive screw at the top and one at the bottom right side of the fan tray.
 - a. Loosen the bottom captive screw.
 - b. Loosen the top captive screw while supporting the weight of the fan tray with your other hand.

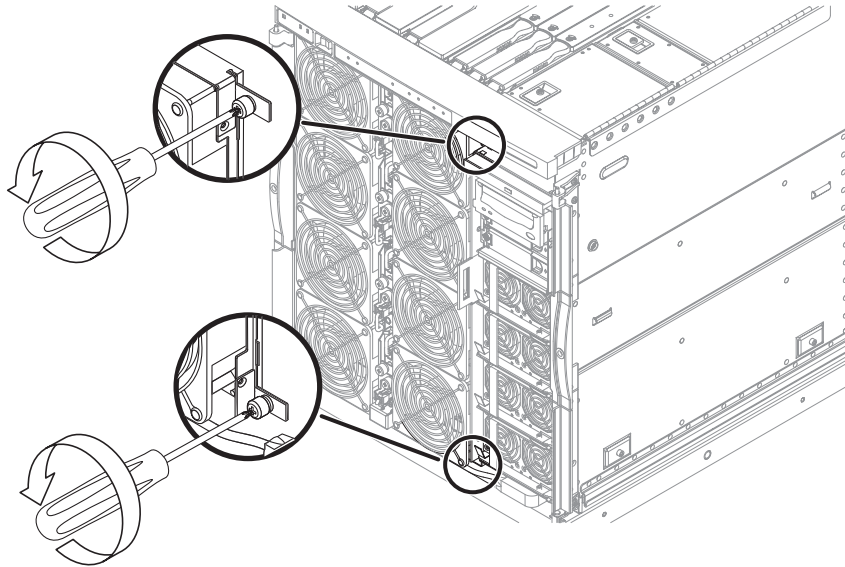

FIGURE 7-6 Loosening the Fan Tray Captive Screws

8. Pull the tray slightly to the right to disengage the mounting pins (FIGURE 7-7).

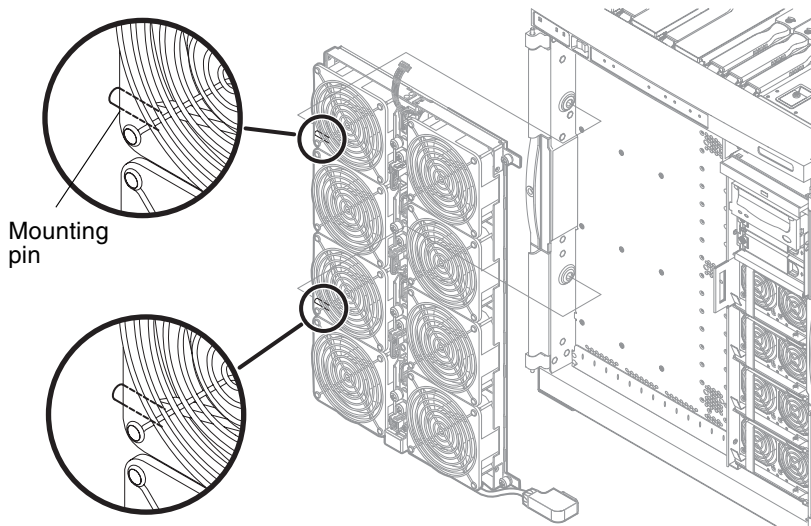

FIGURE 7-7 Removing the Fan Tray



Caution – The fan tray is heavy. Take care when disengaging it from its mountings.

9. Remove the tray and place it on an ESD mat.

7.2.2 Installing the Main Fan Tray

1. Open the front doors of the system.
2. Attach a wrist strap. Place a grounded ESD mat close to the system.
See [Section 2.8, “Antistatic Precautions”](#) on page 2-6.
3. Orient the tray so that the mounting pins align with the cutouts in the system chassis on the left side.
4. Gently push the tray into place.
5. Tighten the two captive screws, one at the top and one at the bottom right side (FIGURE 7-6).

This action secures the fan tray.

6. Connect the fan tray power connector. Lock it by pushing it slightly upwards while pressing the locking clip to the right with a screwdriver (FIGURE 7-5).
7. Connect the system indicator board connector to the receptacle at the top of the fan tray. Replace the retaining clip (FIGURE 7-8).

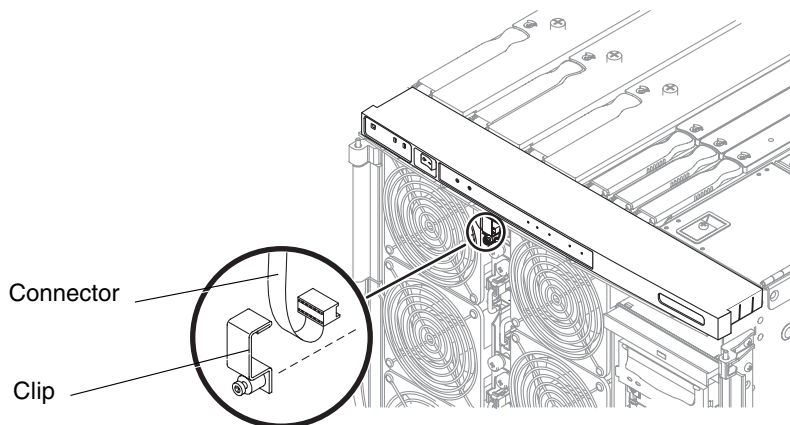

FIGURE 7-8 Replacing the System Indicator Board Connector Retaining Clip

8. Remove the wrist strap.
9. Close the front doors to the system.

7.3 IB Fans

Two IB fans (I/O assembly fans) supply cooling for this unit.



Caution – Use proper ESD grounding techniques when handling components. Wear an antistatic wrist strap and use an ESD-protected mat. Store ESD-sensitive components in its ESD safe packaging box before placing them on any surface.



Caution – This procedure requires the system to be extended out of the system cabinet on its slides. Before attempting this procedure you must deploy system cabinet stabilization devices, if fitted.

IB fan0 and IB fan1 are located at the top of the system. Each IB fan has one LED, fault LED (). The LED is lit when there is a fault. It is off when there is no fault.

7.3.1 Removing an IB Fan

1. **Extend and lock the system cabinet stabilizer bar.**

See [Section 3.1, “Sliding the System Out of the System Cabinet”](#) on page 3-1 and [Section 3.2, “Sliding the System Into the System Cabinet”](#) on page 3-5.



Caution – Failure to extend and lock the stabilizer bar before you slide a system out of the rack can cause the system cabinet to tip over.

2. **Slide the system out of the system cabinet until the locking latches click.**
See [“Sliding the System Out of the System Cabinet”](#) on page 3-1.
3. **Attach a wrist strap. Place a grounded ESD mat close to the system.**
See to [Section 2.8, “Antistatic Precautions”](#) on page 2-6.
4. **At the top of the system, open the IB fan cover.**
 - a. **Loosen the latch screw.**
 - b. **Unlatch the cover and open it** ([FIGURE 7-9](#)).

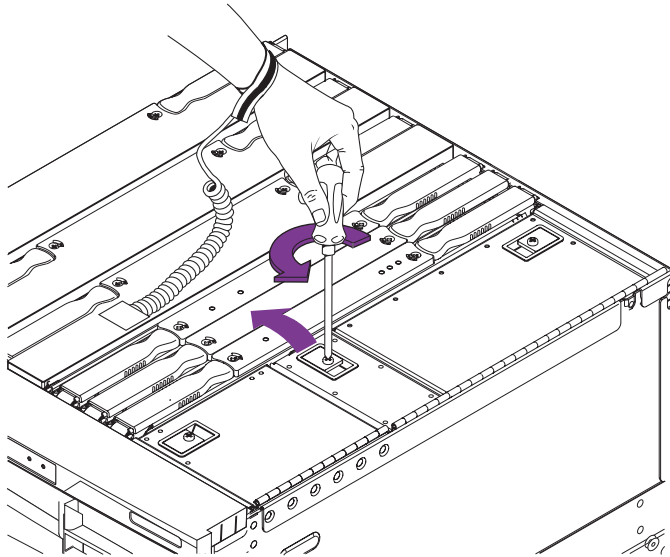

FIGURE 7-9 Opening the IB Fan Cover—System Top View

5. Identify the fan to be removed. Disconnect the power connector (FIGURE 7-10).

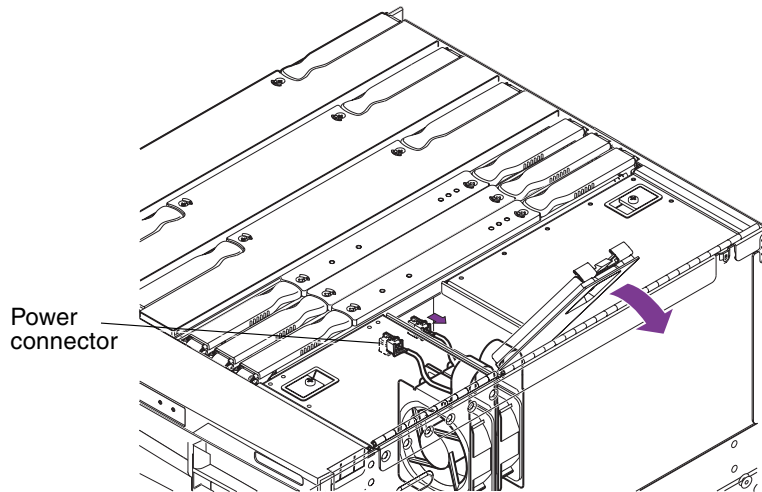

FIGURE 7-10 Identifying the Fan Power Connector



Caution – Wait at least ten seconds before removing the fan to allow it to stop rotating. The remaining fan will still be rotating. There are no finger guards. Take care not to touch any part of the fan.



Caution – Do not operate the system for an extended time period with fan removed. Doing so may cause overheating and system shutdown.

6. From the right side of the system, lift the fan out of the chassis using the metal loop (FIGURE 7-11).

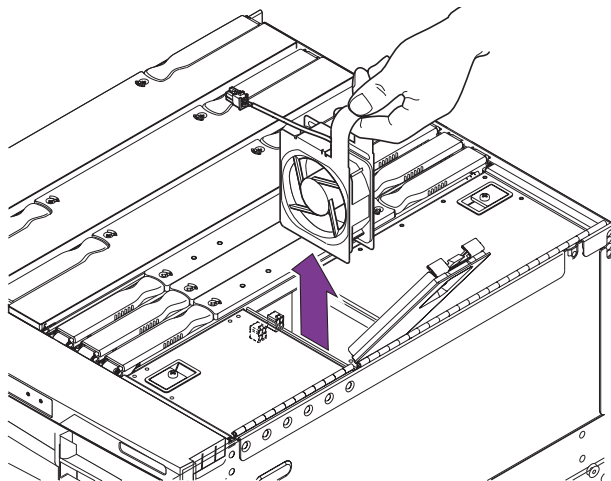

FIGURE 7-11 Removing an IB_SSC Fan

7.3.2 Installing an IB Fan

1. **Make sure that the system cabinet stabilizer bar is extended and locked.**
See [Section 3.1, “Sliding the System Out of the System Cabinet”](#) on page 3-1 and [Section 3.2, “Sliding the System Into the System Cabinet”](#) on page 3-5.
2. **Make sure that the system is extended out of the system cabinet.**
3. **Attach a wrist strap. Place a grounded ESD mat close to the system.**
See [Section 2.8, “Antistatic Precautions”](#) on page 2-6.
4. **Open the IB fan cover.**
 - a. **Loosen the latch screw.**
 - b. **Unlatch the cover and open it** ([FIGURE 7-9](#)).
5. **Lower the fan into the chassis using the metal loop.**
6. **Connect the power connector to the fan** ([FIGURE 7-10](#)).



Caution – If the system is powered on, the fan will start as soon as the connector is inserted.

7. **Close and latch the IB fan cover.**

- 8. Remove the wrist strap.**
- 9. Slide the system back into the chassis and secure it.**
- 10. Retract the system cabinet stabilization bar.**

Power Subsystem

This chapter describes how to remove and install the various parts of the power subsystems. It contains the following topics:

- Section 8.1, “Power Supplies” on page 8-2
- Section 8.2, “Power Inlet Box” on page 8-4
- Section 8.3, “Power Distribution Board” on page 8-6

You can replace a power supply without powering down the system.

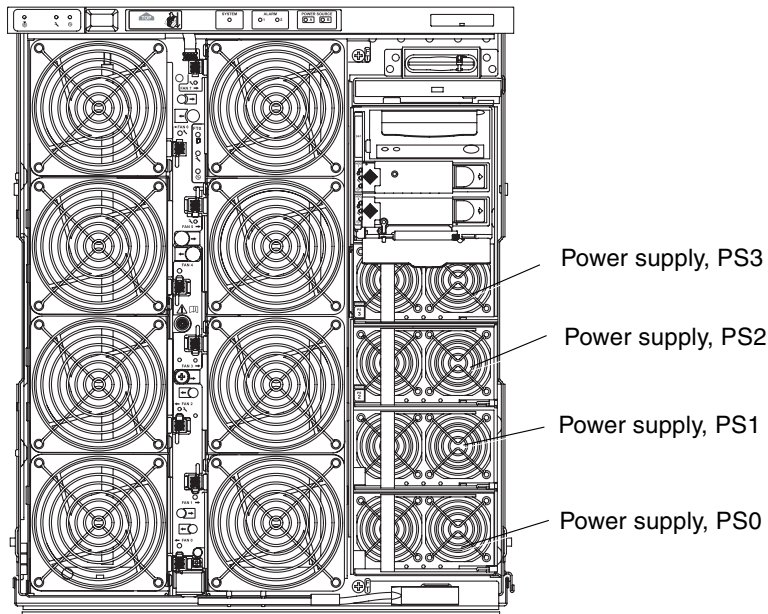

FIGURE 8-1 Power Supply Locations

8.1 Power Supplies



Caution – Use proper ESD grounding techniques when handling components. Wear an antistatic wrist strap and use an ESD-protected mat. Store ESD-sensitive components in its ESD safe packaging box before placing them on any surface

Note – In order for the system to function correctly, a minimum of two power supplies must be powered on and operating.

The power supplies are located at the front of the system below the disk drives (FIGURE 8-1). Each power supply has three LEDs (TABLE 8-1).

TABLE 8-1 Power Supply LED Descriptions

LED Name		On	Off	Blinking
Activated LED (green)		Power supply activated and operating normally.	Power supply deactivated.	System is in Standby mode.
Predictive fault LED (amber)		Power supply detected a pending internal fault. Consider replacing the power supply.	Power supply fan speed is not below a specified level.	Power supply fan speed is below a specified level.
Fault LED (amber)		Fault present. Replace the power supply.	No fault present.	N/A

Note – As long as a minimum of two power supplies are powered on and operating normally (with only the activated LED lit), you can remove one of the other power supplies.

8.1.1 Removing a Power Supply

Note – The power supplies are hot-swappable.

1. Open the right front door of the system.
2. Attach a wrist strap to your wrist. Connect the ESD wrist strap to the system.
See [Section 2.8, “Antistatic Precautions”](#) on page 2-6.
3. Identify the power supply to be removed.
4. Unlatch the power supply ([FIGURE 8-2](#) and [FIGURE 8-3](#)).
 - a. Push in the green spring on the left of the power supply (marked ‘1’) and pull open the ejector lever (marked ‘2’).
 - b. Remove the power supply from the system ([FIGURE 8-3](#)).

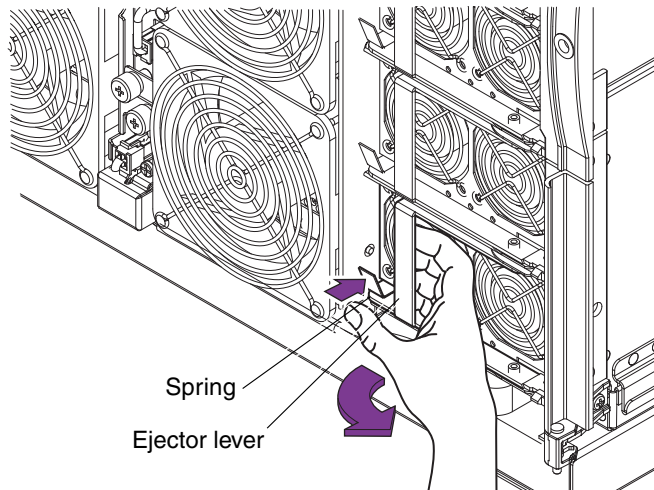

FIGURE 8-2 Unlatching a Power Supply

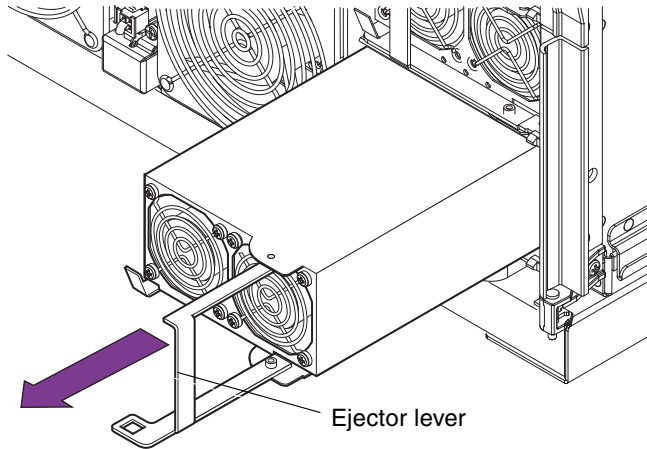

FIGURE 8-3 Removing a Power Supply

5. Place it on an ESD mat.

8.1.2 Installing a Power Supply

1. Open the right front door of the system.
2. Attach a wrist strap to your wrist. Connect the ESD wrist strap to the system.
See [Section 2.8, "Antistatic Precautions" on page 2-6.](#)
3. Extend the ejector lever from the power supply ([FIGURE 8-3](#)).
4. Push the power supply fully into its slot and close the ejector lever.
5. Close the front door.
6. Remove the wrist strap.

8.2 Power Inlet Box



Caution – Use proper ESD grounding techniques when handling components. Wear an antistatic wrist strap and use an ESD-protected mat. Store ESD-sensitive components in its ESD safe packaging box before placing them on any surface

The power inlet box is located at the left rear of the system just to the right of the metal perforations (FIGURE 8-4).

8.2.1 Removing the Power Inlet Box

1. Take the system to Standby mode.
See [Section 4.2, “Taking the System to Standby Mode”](#) on page 4-2.
2. Remove power to the system by removing the four input power cables, AC0 through AC4 (FIGURE 1-3 and TABLE 1-1).
3. Attach a wrist strap to your wrist. Connect the ESD wrist strap to the system.
See [Section 2.8, “Antistatic Precautions”](#) on page 2-6.
4. Remove the four Phillips no. 2 screws retaining the inlet box (FIGURE 8-4).

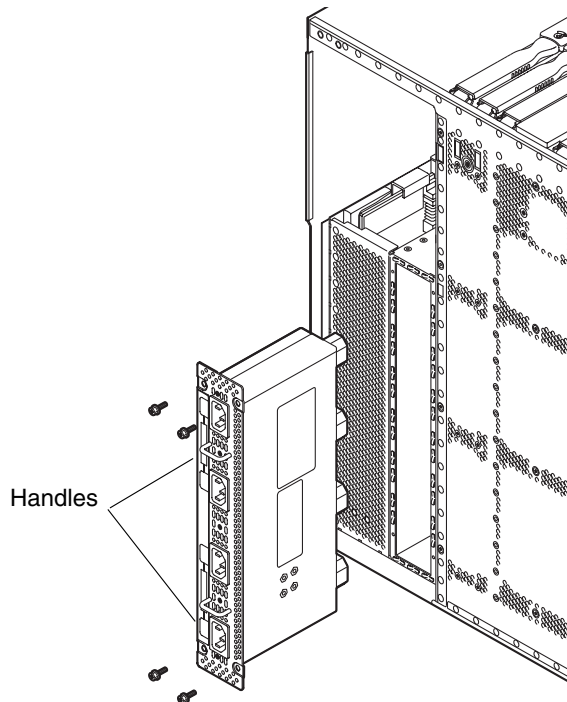

FIGURE 8-4 Removing the Power Inlet Box

5. Remove the inlet box using the two handles and place it on an ESD mat.

8.2.2 Installing the Power Inlet Box

1. Insert the power inlet box into the rear of the system and secure the inlet box by using the four Phillips no. 2 screws (FIGURE 8-4).
2. Return power to the system by reconnecting the four power input cables, AC0 through AC4 (FIGURE 1-3).
3. Detach the wrist strap.
4. Power on the system.

See Section 4.1, “Powering On the System” on page 4-1.

8.3 Power Distribution Board



Caution – Use proper ESD grounding techniques when handling components. Wear an antistatic wrist strap and use an ESD-protected mat. Store ESD-sensitive components in its ESD safe packaging box before placing them on any surface



Caution – This procedure requires the system to be extended out of the system cabinet on its slides. You must extend the system cabinet stabilizer bar.

The power distribution board is located in the system. It is accessible from the rear of the system after your remove the IB_SSC assembly (FIGURE 8-6).

8.3.1 Removing the Power Distribution Board

1. Take the system to Standby mode.
See Section 4.2, “Taking the System to Standby Mode” on page 4-2.
2. Remove the four power input cables, AC0 through AC4 (FIGURE 1-3).
This action removes power to the system.
3. Make sure that the leveling feet are extended to the floor.
4. Extend and lock the system cabinet stabilizer bar.

See Section 3.1, “Sliding the System Out of the System Cabinet” on page 3-1 and Section 3.2, “Sliding the System Into the System Cabinet” on page 3-5.



Caution – Failure to extend and lock the stabilizer bar before you slide a system out of the rack will cause the system cabinet to tip over.

5. **Slide the system out of the system cabinet until the locking latches click.**
See [Section 3.1, “Sliding the System Out of the System Cabinet”](#) on page 3-1.
6. **Open the right front door.**
7. **Attach a wrist strap to your wrist. Connect the ESD wrist strap to the system.**
See [Section 2.8, “Antistatic Precautions”](#) on page 2-6.
8. **Remove the IB_SSC assembly.**
See [Section 10.1.1, “Removing the IB_SSC Assembly”](#) on page 10-2.
9. **Unlatch all power supplies. Do not completely remove them from the system.**
See [Section 8.1.1, “Removing a Power Supply”](#) on page 8-3.
10. **Raise the power distribution board ejector lever until it is vertical (FIGURE 8-5).**

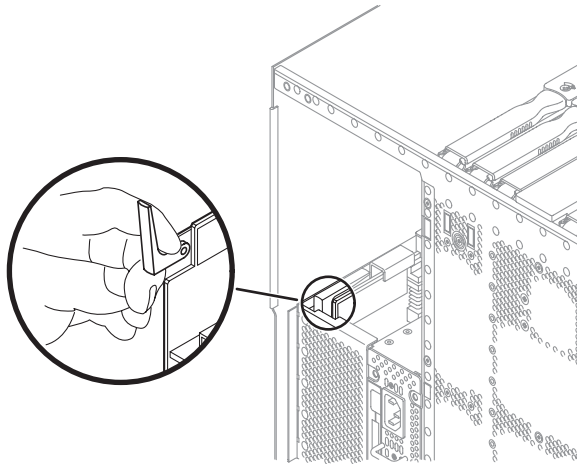

FIGURE 8-5 Unlatching the Power Distribution Board Ejector Lever

11. **Remove the board from the system using the metal handle (FIGURE 8-6). Place the board on an ESD mat.**

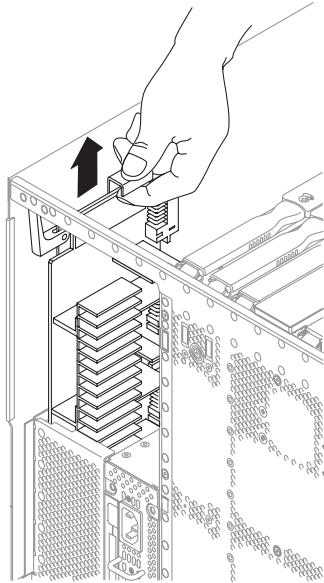

FIGURE 8-6 Removing the Power Distribution Board

8.3.2 Installing the Power Distribution Board

1. Make sure that the leveling feet are extended to the floor.
2. Extend and lock the system cabinet stabilizer bar.

See [Section 3.1, “Sliding the System Out of the System Cabinet”](#) on page 3-1 and [Section 3.2, “Sliding the System Into the System Cabinet”](#) on page 3-5.



Caution – Failure to extend and lock the stabilizer bar before you slide a system out of the rack will cause the system cabinet to tip over.

3. Slide the system out of the system cabinet until the locking latches click.
See [Section 3.1, “Sliding the System Out of the System Cabinet”](#) on page 3-1.
4. Attach a wrist strap to your wrist. Connect the ESD wrist strap to the system.
See [Section 2.8, “Antistatic Precautions”](#) on page 2-6.
5. Align the power distribution board with the card guides. Gently slide it down to engage with the baseplane ([FIGURE 8-7](#)).

6. Press down firmly to ensure the connector at the base of the board is firmly mated with the receptacle on the baseplane.

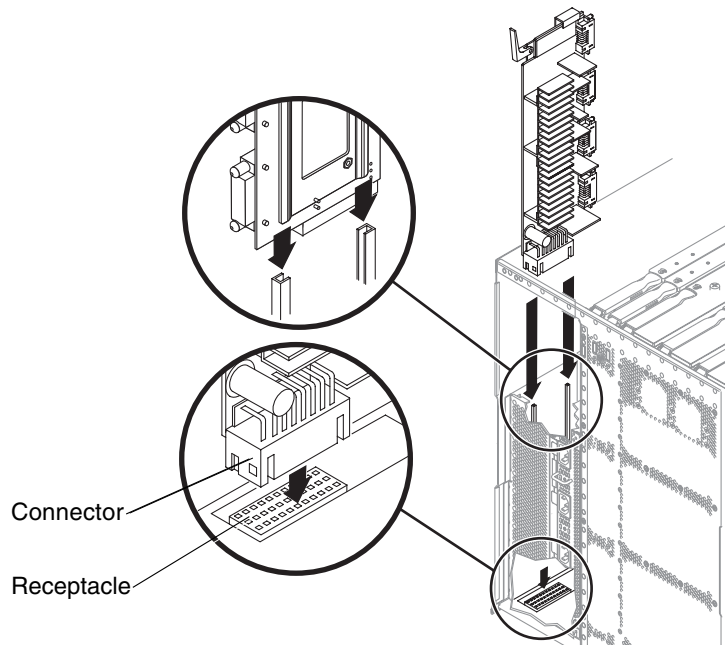

FIGURE 8-7 Inserting the Power Distribution Board

7. Move the ejector lever to the horizontal position ([FIGURE 8-5](#)).
8. Re-engage the power supplies.
9. Install the IB_SSC assembly.
See [Section 10.1.2, "Installing the IB_SSC Assembly"](#) on page 10-7.
10. Remove the wrist strap.
11. Slide the system into the system cabinet.
See [Section 3.2, "Sliding the System Into the System Cabinet"](#) on page 3-5.
12. Retract the system cabinet stabilization bar.
13. Replace the four power input cables, AC0 through AC4 ([FIGURE 1-3](#)).
14. Power on the system.
See [Section 4.1, "Powering On the System"](#) on page 4-1.

CPU/Memory Boards

This chapter explains how to install a CPU/Memory board filler board, install and remove the CPU/Memory board, and install and remove DIMMs. This chapter contains the following topics:

- [Section 9.1, “Filler Boards” on page 9-2](#)
- [Section 9.2, “CPU/Memory Boards” on page 9-3](#)
 - [Section 9.2.1, “Removing a CPU/Memory Board” on page 9-4](#)
 - [Section 9.2.2, “Installing a CPU/Memory Board” on page 9-8](#)
- [Section 9.3, “DIMMs” on page 9-11](#)

Note – If the system is powered on, before you begin this procedure make sure that the fan tray is installed in the system and operating normally. The fan tray cools the CPU/Memory boards.



Caution – This procedure requires the system to be extended out of the system cabinet on its slides. You must extend the system cabinet stabilizer bar.

9.1 Filler Boards



Caution – To prevent the system from overheating, always install a filler board when you permanently remove a CPU/Memory board from a system ([FIGURE 9-1](#)).

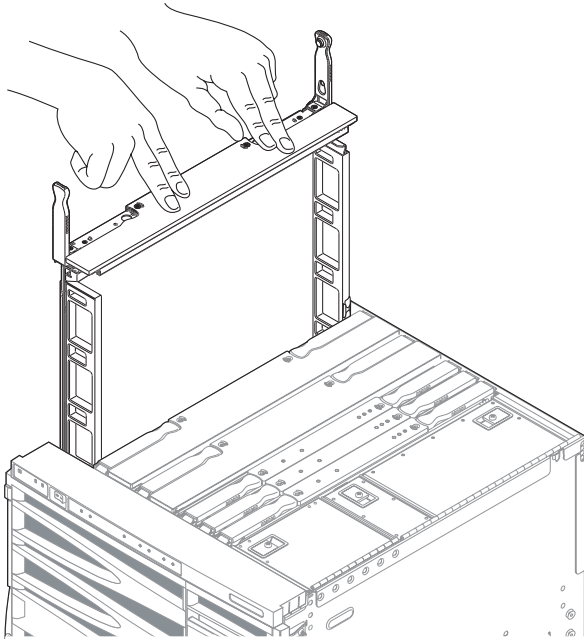

FIGURE 9-1 Inserting a CPU/Memory Filler Board

9.2 CPU/Memory Boards

The CPU/Memory boards (SB0, SB2, and SB4) are removed and replaced from the top of the system (FIGURE 9-2). When you remove a CPU/Memory board from the system, place it in its ESD safe packaging box. The CPU/Memory board box provides two ESD safe work surfaces.

Each CPU/Memory board can support:

- Up to four CPU processors
- Up to 32 DIMMs (dual inline memory modules)
- Up to eight Ecache modules

Each CPU processor can support:

- Two DIMM banks (four DIMMs per bank)
- Up to eight Gbytes of memory
- Two Ecache modules

The memory controller is integrated in the CPU processor. The CPU/Memory board has a metal cover that covers the CPU processors and Ecache.

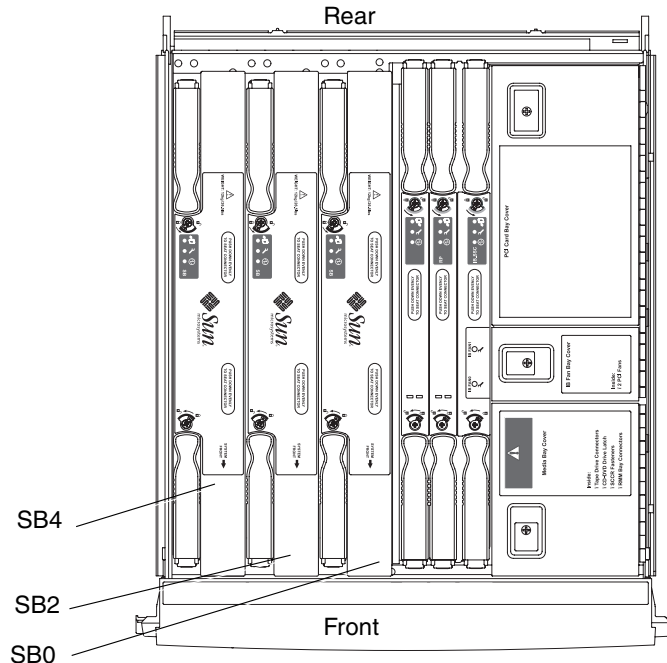





FIGURE 9-2 Top View of the CPU/Memory Boards

There are three LEDs on the CPU/Memory board (TABLE 9-1).

TABLE 9-1 CPU/Memory Board LED Functions

LED Name		On	Off
Activated LED (green)		Device is activated.	Device is deactivated
Fault LED (amber)		Internal fault.	No internal fault.
OK to remove (blue or amber)		Assembly can be removed.	Assembly cannot be removed.

9.2.1 Removing a CPU/Memory Board



Caution – The CPU/Memory board is heavy and weighs approximately 26.5 pounds (12 kg). Take care when removing the board from the system.



Caution – To prevent the system from overheating, always install a filler board when you permanently remove a CPU/Memory board from a system.



Caution – Spring fingers and EMI gaskets may detach from the CPU/Memory board and fall into the system. This may cause damage. Make sure that the EMI gaskets and spring fingers do not fall into the system.

- 1. Unconfigure any resources in use by the CPU/Memory board using dynamic reconfiguration (DR).**

Refer to the system administration manual.

- 2. Detach and power off the board using DR.**

Refer to the system administration manual.

The OK to remove () LED should be lit.

3. Make sure that the leveling feet are extended to the floor.

4. Extend and lock the system cabinet stabilizer bar.

See [Section 3.1, “Sliding the System Out of the System Cabinet”](#) on page 3-1 and [Section 3.2, “Sliding the System Into the System Cabinet”](#) on page 3-5.



Caution – Failure to extend and lock the stabilizer bar before you slide a system out of the rack will cause the system cabinet to tip over.

5. Slide the system out of the system cabinet until the locking latches click.

See [“Sliding the System Out of the System Cabinet”](#) on page 3-1.

6. Be sure that you have a filler board (if necessary) or a replacement board ready.

See [Section 9.1, “Filler Boards”](#) on page 9-2.

7. Attach the ESD wrist strap. Place a grounded ESD mat close to the system.

See [Section 2.8, “Antistatic Precautions”](#) on page 2-6.

8. Unlock the ejector levers on the CPU/Memory board using a Phillips no. 2 screwdriver ([FIGURE 9-3](#)).

The ejectors will pop out slightly.

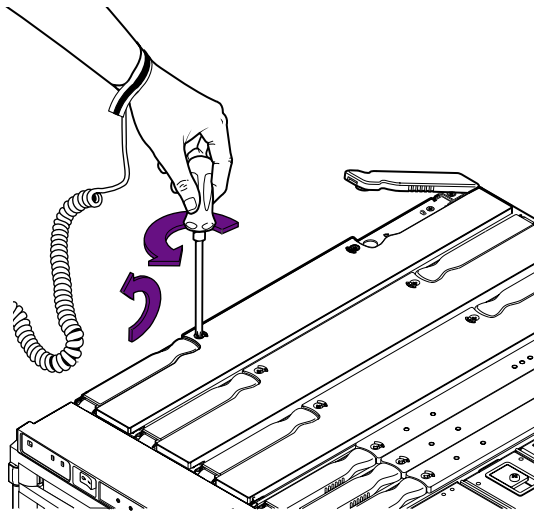

FIGURE 9-3 Unlocking the CPU/Memory Board Ejector Levers

9. Raise the ejector levers simultaneously until they are 90 degrees straight out from the board (FIGURE 9-4).

This action unseats the board from the baseplane connector.

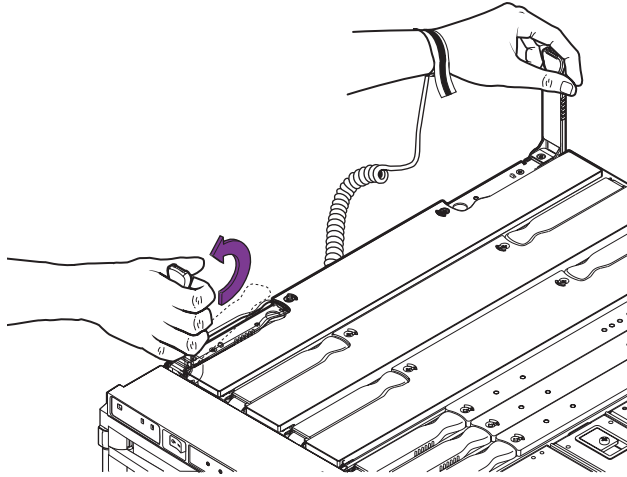

FIGURE 9-4 Raising the CPU/Memory Board Ejector Levers

10. Grasp the ejector levers and pull upward to raise the CPU/Memory board until the green panels are visible.

The antigravity clutch holds the board in position so that it can be released without the board sliding down into the system.

Note – Any green part is a part that you can touch.

11. Grasp the green panels and raise the CPU/Memory board out of the system (FIGURE 9-5).
12. Place the board in its ESD safe packaging box on a grounded ESD mat.

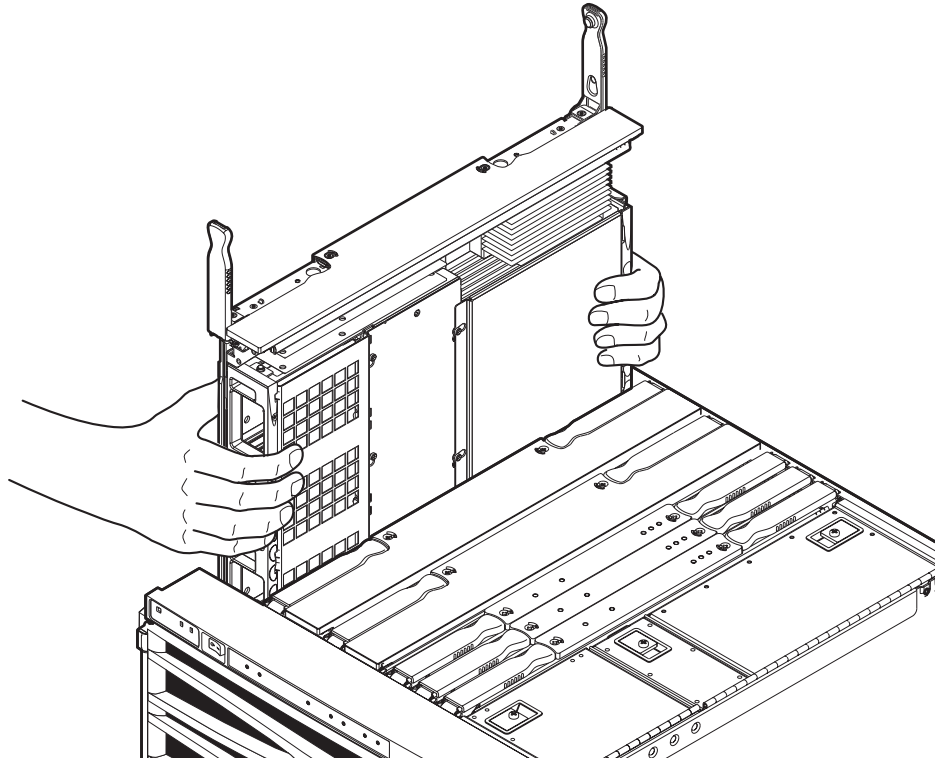

FIGURE 9-5 Raising a CPU/Memory Board From the System

13. Remove the DIMMs and install them on the replacement board (if one is to be fitted).

See [Section 9.3.2, “Removing DIMMs”](#) on page 9-12.



Caution – Install a filler board in the empty slot if a replacement board is not going to be installed. The installed filler board prevents overheating when the system is powered on.

9.2.2 Installing a CPU/Memory Board

1. Attach the ESD wrist strap. Place a grounded ESD mat close to the system.
See [Section 2.8, “Antistatic Precautions”](#) on page 2-6.
2. Install DIMMs on the CPU/Memory board, if required.
See [Section 9.3.3, “Installing DIMMs”](#) on page 9-15.
3. Remove the CPU/Memory board filler board, if fitted.



Caution – *Do not force* any board into a slot; it can cause damage to the board and system. The board should insert and seat smoothly. If it binds, remove the board and inspect the card cage slot for any obvious obstructions. Also inspect both the board and the baseplane for bent pins or other damage.

4. Visually inspect the connector(s) for damage.
5. Grasp the green side panels and gently insert the CPU/Memory board into the grooves until the antigravity clutch is engaged ([FIGURE 9-5](#)).

The antigravity clutch holds the board in position so that it can be released without the board sliding down into the system.

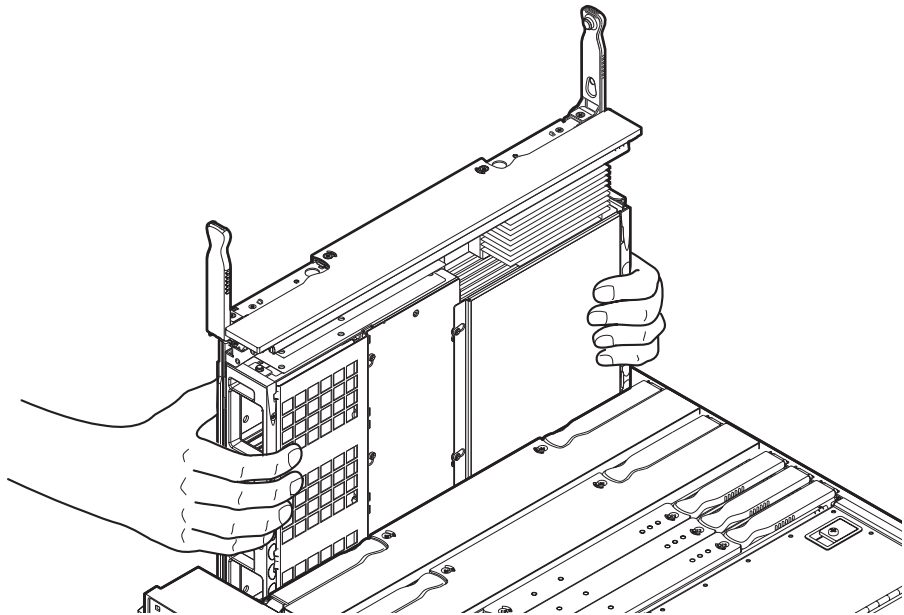

FIGURE 9-6 Installing a CPU/Memory Board

6. Slowly push down from the center top of the CPU/Memory board until the top face of the board is approximately three or four inches (7.5 cm to 10 cm) from the top of chassis.

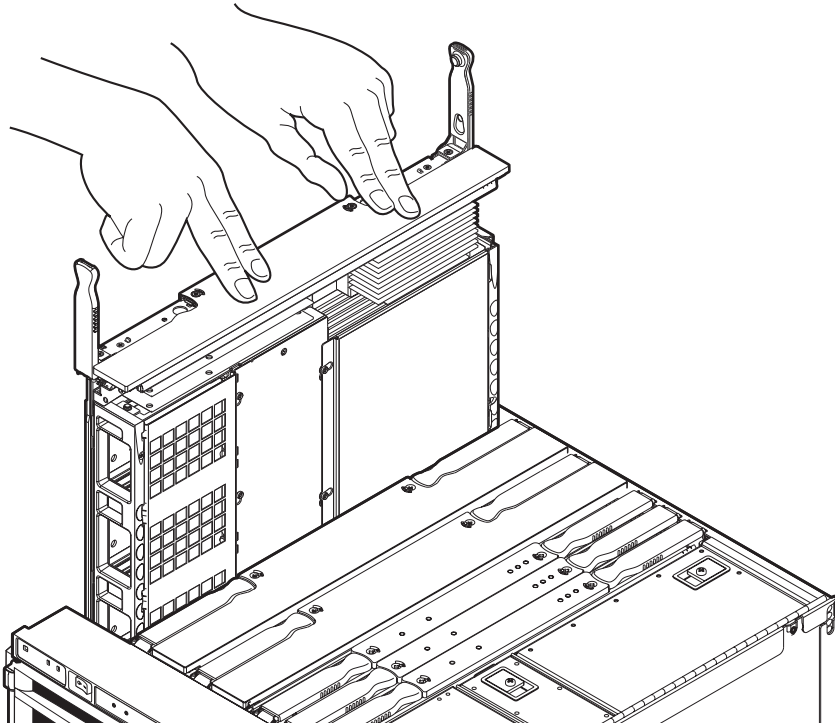

FIGURE 9-7 Partially Inserting the CPU/Memory Board Into the System

7. When the board is approximately three or four inches (7.5 cm to 10 cm) from the top of the chassis, change your grip and grasp the ejector levers so that they are oriented in the vertical position, 90 degrees straight out from the board.



Caution – Metal pins on the underside of the ejector levers help to cushion the CPU/Memory board after the antigravity clutch is released. If the levers are not 90 degrees straight out from the top of the board, there is a chance the connectors could be damaged.

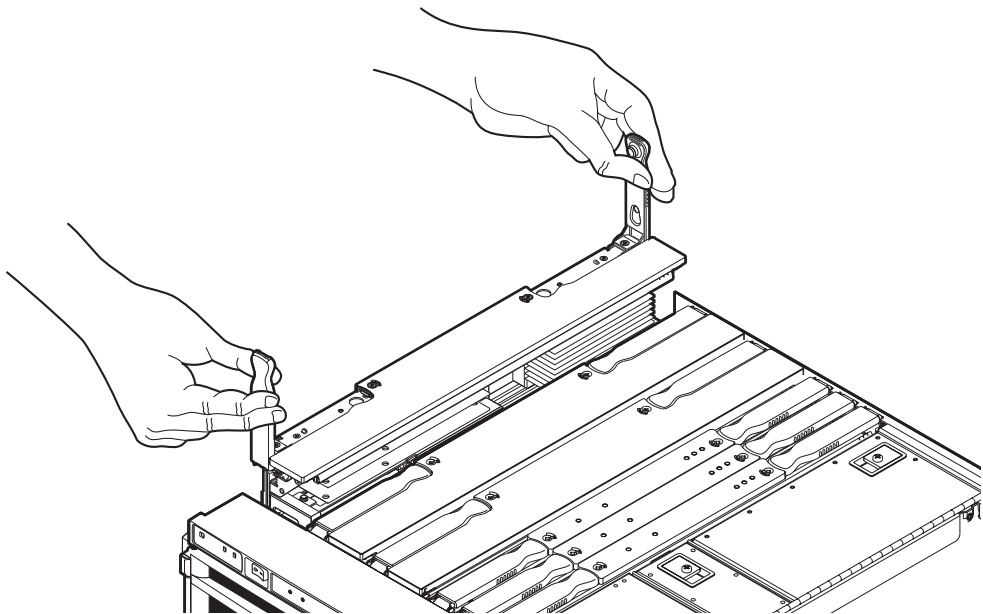

FIGURE 9-8 Changing Hand Grip and Lowering the CPU/Board Into the System

8. To complete the seating, lower the board using the ejector levers until the levers are forced approximately 45 degrees towards the inside of the board.
9. Reposition your grip on the levers and then push down on the levers to lock them into place.
10. Remove the wrist strap.
11. Slide the system back into the chassis and secure it.
See [Section 3.1, "Sliding the System Out of the System Cabinet" on page 3-1.](#)
12. Retract the system cabinet stabilization bar.

13. Power on the system. Then test and configure the board using DR.
Refer to the system administration manual.

9.3 DIMMs

The CPU/Memory board has 32 DIMM sockets, which are divided into eight banks of four DIMMs per bank (FIGURE 9-9). Each CPU processor has two corresponding DIMM banks. A CPU processor is not required to have any DIMMs installed in its corresponding DIMM bank. However, a populated DIMM bank must have a corresponding CPU processor installed.

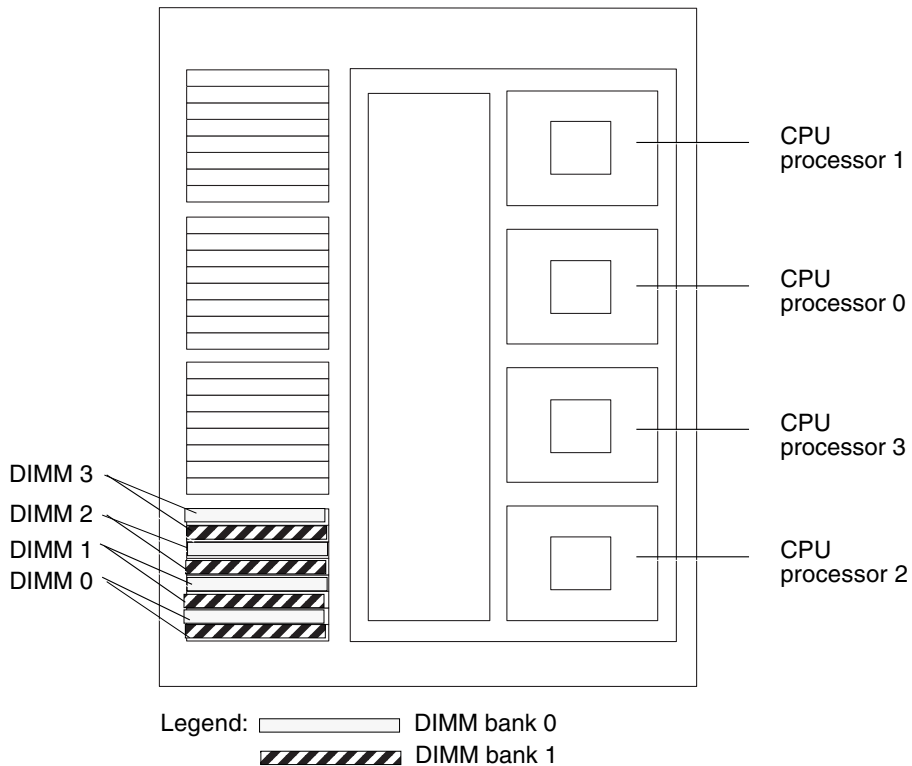

FIGURE 9-9 DIMM Slot Numbers

The DIMM number and bank number are repeated in the same order for each CPU processor. DIMM number 3, bank 0 is the first DIMM, and DIMM number 3, bank 1 is the second DIMM in each DIMM bank. The CPU processor number is noted on the metal cover.

9.3.1 DIMM Bank Configuration Guidelines

Follow these DIMM configuration guidelines:

- Each DIMM bank must be fully populated with the same capacity DIMM.
- Install the larger capacity DIMMs into banks before installing the smaller capacity DIMMs into banks.
- The minimum number of DIMMs you can install per CPU processor is four DIMMs for one bank.
- If the number of CPU processors on each CPU/Memory board is the same, place DIMM banks on CPU/Memory boards that have fewer populated DIMM banks before placing DIMMs on CPU/Memory boards that already have more populated DIMM banks.
- If some CPU/Memory boards have more CPU processors than others, place DIMMs in DIMM banks on the board with the most CPU processors. There will be CPU processors without corresponding DIMMs on other boards.

9.3.2 Removing DIMMs



Caution – The system is sensitive to static electricity. Make sure you are wearing a grounded wrist strap when handling system components. Always place components on a grounded ESD mat close to the system

1. Remove the applicable CPU/Memory board.

See [Section 9.2.1, “Removing a CPU/Memory Board” on page 9-4.](#)

2. Place the CPU/Memory board on the ESD mat.

3. Remove the four screws that retain the DIMM cover. Remove the cover (FIGURE 9-10).

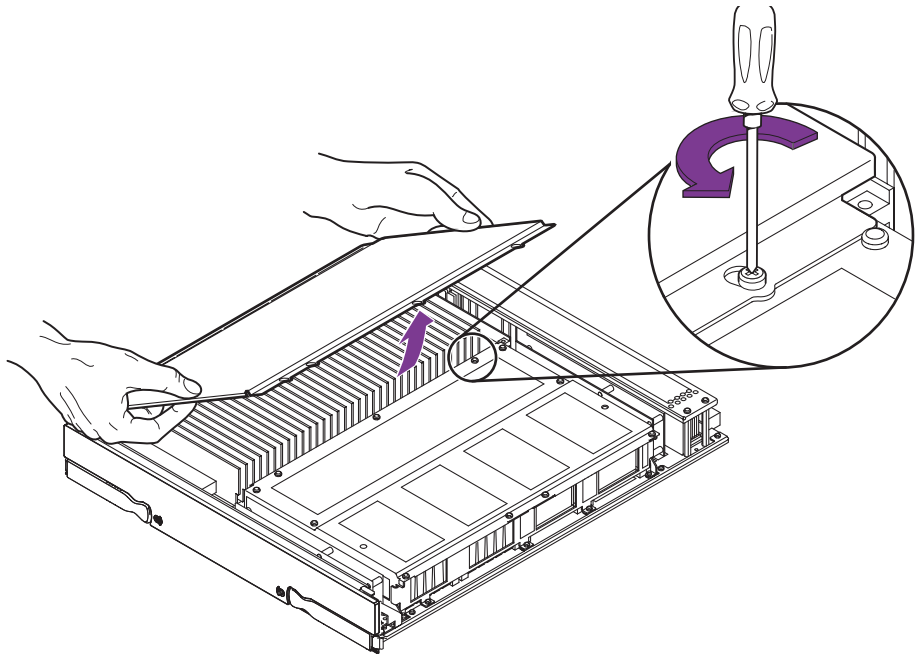

FIGURE 9-10 Removing the DIMM Cover

4. Locate the slot for the DIMM you need to replace.

5. Eject the faulty DIMM by pressing down on the ejection levers on both sides of the DIMM connector (FIGURE 9-11).

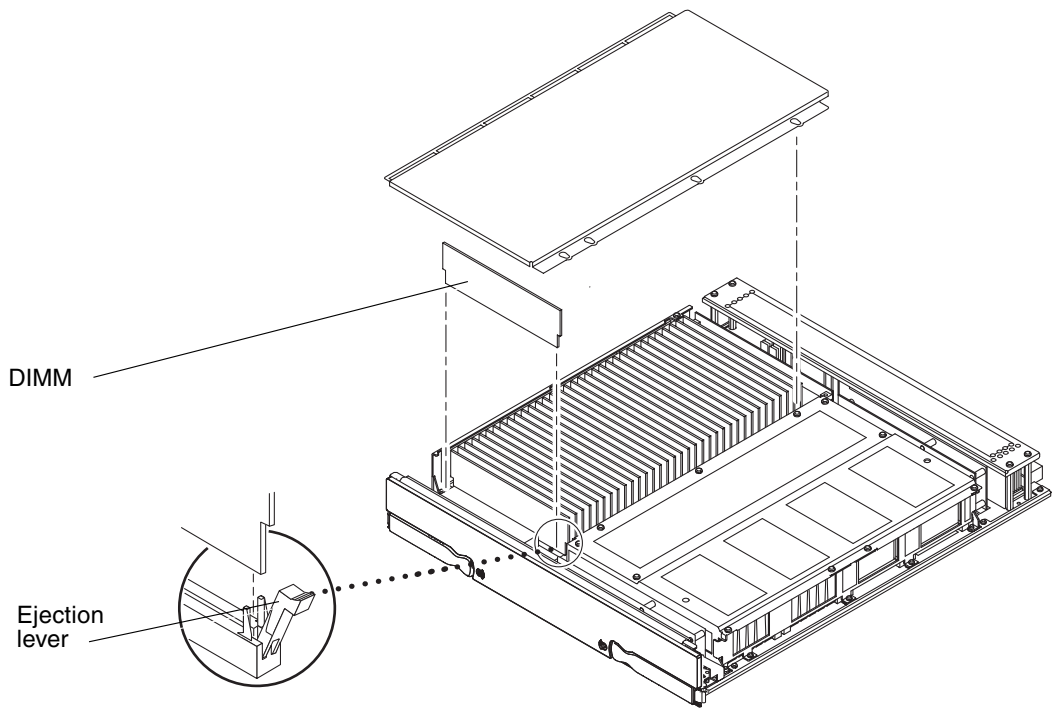

FIGURE 9-11 Removing a DIMM

6. Holding the DIMM by its edges, remove it from the slot and place it on an antistatic surface.
7. If you are not going to install new DIMMs, replace the DIMM cover and secure it using the four screws.

9.3.3 Installing DIMMs

Install one bank completely on each board before installing the remaining banks on any board.

Note – All banks must have the same size DIMMs. However, DIMMs from different manufacturers are interchangeable in a single bank if the DIMMs all have the same capacity and speed. Sort the DIMMs into banks using the same size DIMMs.



Caution – The system and DIMMs are sensitive to static electricity. To prevent damage to the DIMMs, make sure you are wearing a grounded wrist strap when handling them. Always place components on a grounded ESD mat close to the system.

1. Remove the CPU/Memory board.

See [Section 9.2.1, “Removing a CPU/Memory Board”](#) on page 9-4.

2. Place the CPU/Memory board on an ESD mat on a work surface.

3. Remove the four screws retaining the DIMM cover. Remove the cover (FIGURE 9-10).

4. Carefully remove the new DIMM from its protective packaging and place it on an antistatic surface.

The DIMM bag makes a good antistatic surface.

5. Press down on the ejector levers at both ends of the DIMM connector slot that will receive the new DIMM.

The connector slot will not accept the DIMM unless the levers are in the insert (open) position.

6. Align the short-side key and the long-side key on the DIMM with the short side and long side of the DIMM connector.

Note – If you are installing four DIMMs, insert the DIMMs into the same bank.

7. Place your thumbs on the top edge of the DIMM. Push the DIMM firmly into its connector ([FIGURE 9-12](#)).

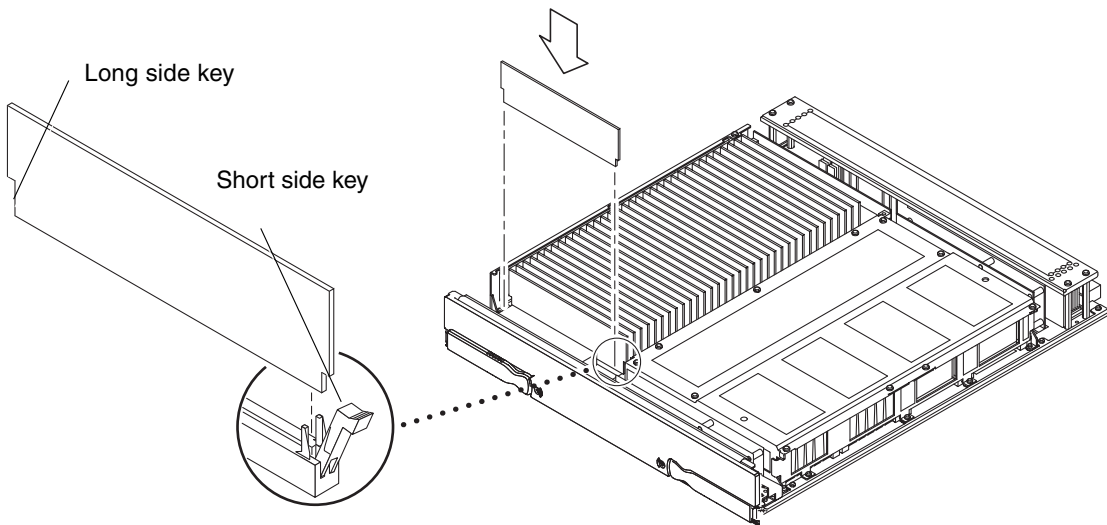

FIGURE 9-12 Installing a DIMM

8. **Press down firmly on the entire edge of the DIMM.**
The ejector levers will be in the upright position.
9. **Install each DIMM in the same manner.**
10. **Replace the DIMM cover and secure the cover with the four screws.**
11. **Reinstall the CPU/Memory board.**
See [Section 9.2.2, "Installing a CPU/Memory Board"](#) on page 9-8.

IB_SSC Assembly

This chapter describes how to install and remove the IB_SSC assembly and PCI cards. It contains the following topics:

- Section 10.1.1, “Removing the IB_SSC Assembly” on page 10-2
- Section 10.1.2, “Installing the IB_SSC Assembly” on page 10-7
- Section 10.2.1, “Removing a PCI Card” on page 10-9
- Section 10.2.2, “Installing a PCI Card” on page 10-12

10.1 IB_SSC Assembly

The IB_SSC assembly, IB_SSC, is located on the top of the system ([FIGURE 10-1](#)).

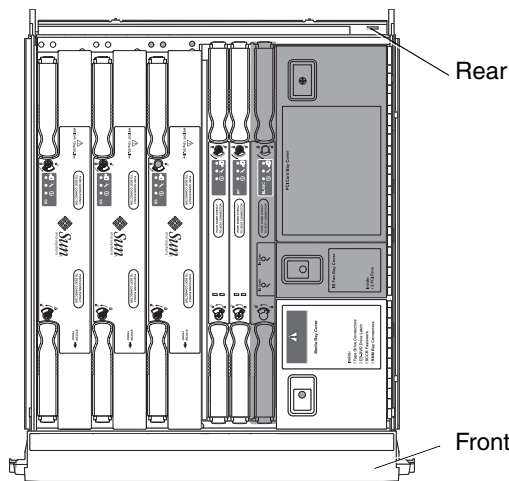





FIGURE 10-1 IB_SSC Assembly Location—System Top View

TABLE 10-1 lists the IB_SSC assembly LED functions.

TABLE 10-1 IB_SSC Assembly LED Functions

IB_SSC LED Name		On	Off
Activated LED (green)		Board is activated.	Board is deactivated.
Fault LED (amber)		Fault is present.	No fault is present.
OK to remove (blue or amber)		Assembly can be removed.	Assembly cannot be removed.

10.1.1 Removing the IB_SSC Assembly



Caution – The IB_SSC assembly is heavy and weighs approximately 24 pounds (11 kg); it is also an awkward shape to handle. Take care when removing the board from the system.



Caution – Spring fingers and EMI gaskets may detach from the IB_SSC assembly and fall into the system. This may cause damage. Make sure that the EMI gaskets and spring fingers do not fall into the system.



Caution – This procedure requires the system to be extended out of the system cabinet on its slides. Before attempting this procedure you must extend the system cabinet stabilization bar.

- 1. Take the system to Standby mode.**

See [Section 4.2, “Taking the System to Standby Mode”](#) on page 4-2.

- 2. Make sure that the leveling feet are extended to the floor.**

- 3. Extend and lock the system cabinet stabilizer bar.**

See [Section 3.1, “Sliding the System Out of the System Cabinet”](#) on page 3-1 and [Section 3.2, “Sliding the System Into the System Cabinet”](#) on page 3-5.



Caution – Failure to extend and lock the stabilizer bar before you slide a system out of the cabinet may cause the system cabinet to tip over.

4. Remove the four input power cables, AC0 through AC4 ([FIGURE 1-3](#) and [TABLE 1-1](#)).
5. If you are going to remove PCI cards (removing and replacing the power distribution board does not require removing PCI cards), do the following:
 - a. Prepare an ESD safe work surface for the PCI cards you are going to remove.
 - b. Remove all I/O cables and label them. Label all PCI cables that are attached to the IB_SSC assembly at the rear of the system.
6. Slide the system out of the system cabinet until the locking latches click.
See [Section 3.1, “Sliding the System Out of the System Cabinet”](#) on page 3-1.
7. Attach a wrist strap. Place a grounded ESD mat close to the system.
See [Section 2.8, “Antistatic Precautions”](#) on page 2-6.
8. At the top of the system, open the media bay cover ([FIGURE 10-2](#)).

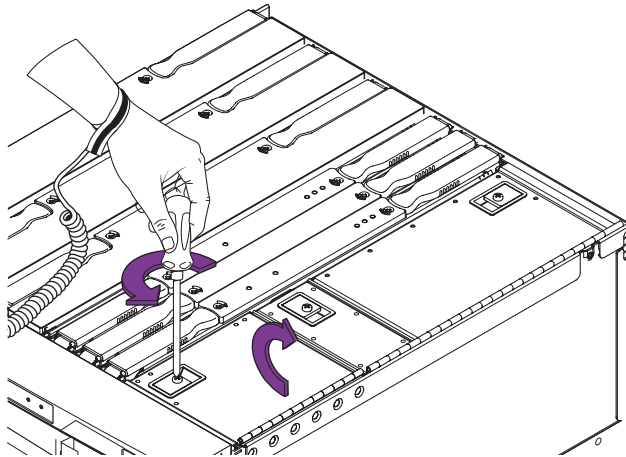

FIGURE 10-2 Opening the Media Bay Cover—System Top View

9. Disconnect the I/O cables from the IB_SSC assembly to the removable media modules (FIGURE 10-3). Secure the cables out of the way.

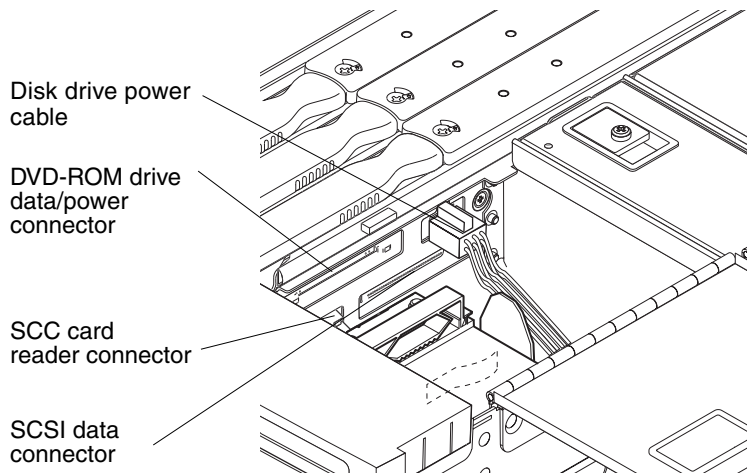

FIGURE 10-3 IB_SSC Assembly Cable and Connector Locations



Caution – Do not disconnect the SSC card reader cable end that connects to the SSC card reader or the SCSI data cable end that connects removable media backplane. Those cable ends are soldered and cannot be removed.

10. Remove the PCI cards from the PCI bay.

See [Section 10.2.1, “Removing a PCI Card”](#) on page 10-9.

Note – If you are replacing the power distribution board, you can leave the PCI cards installed.

11. From the right of the system, unlock the ejector levers on the IB_SSC assembly with a Phillips no. 2 screwdriver (FIGURE 10-4).

The ejectors will pop out slightly.

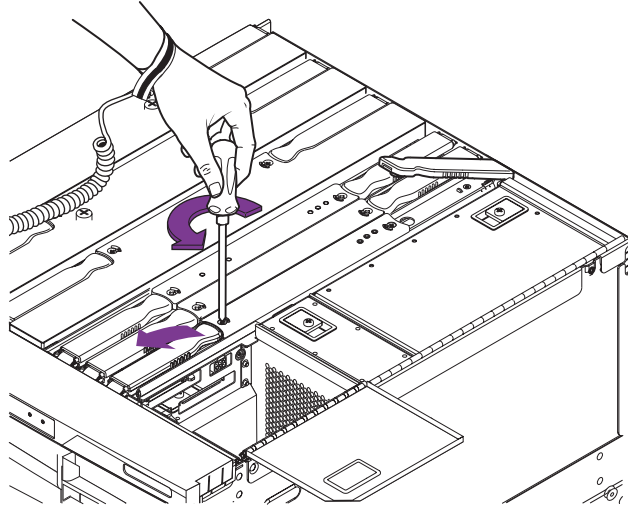

FIGURE 10-4 Unlocking the IB_SSC Assembly Ejector Levers

12. Raise the ejector levers simultaneously until they are 90 degrees straight out from the board.

This action unseats the board from the connector on the baseplane.

13. Grasp the ejector levers and pull to raise the IB_SSC assembly until the green panels are visible (FIGURE 10-5).

The antigravity clutch holds the IB_SSC assembly in position so that it can be released without the board sliding down into the system.

Note – Any green part is a part that you can touch.

14. Hold the green panels and raise the assembly out of the system.



Caution – The IB_SSC assembly is heavy and weighs approximately 24 pounds (11 kg); it is also an awkward shape to handle. Take care when removing the board from the system.

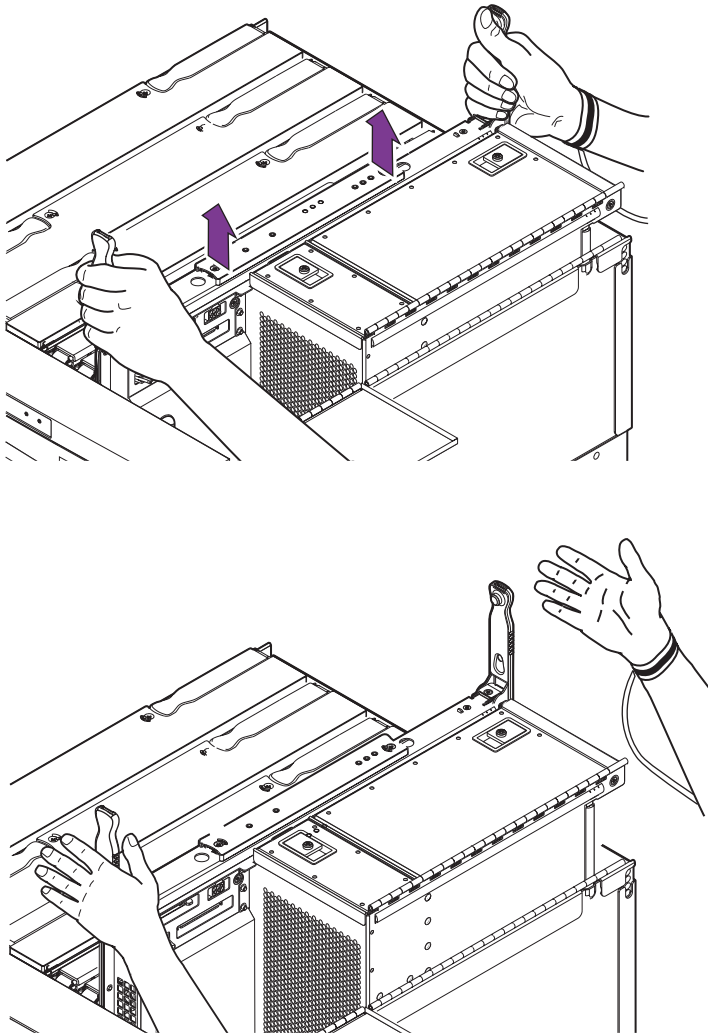

FIGURE 10-5 Raising the IB_SSC Assembly Halfway Using the Antigravity Guides

15. Place the board in its ESD safe packaging box.
16. Place the packaged IB_SSC assembly on a grounded ESD mat.

10.1.2 Installing the IB_SSC Assembly

1. **Attach a wrist strap to your wrist. Connect the ESD wrist strap to the system.**
See [Section 2.8, “Antistatic Precautions”](#) on page 2-6.
2. **Ensure the removable media cables are safely out of the way.**



Caution – *Do not force* any board into a slot; it can cause damage to the board and system. The board should insert and seat smoothly. If it binds, remove the board and inspect the card cage slot for any obvious obstructions. Also inspect both the board and the baseplane for bent pins or other damage.

3. **Visually inspect the connector(s) for damage.**
4. **Hold the green side panels and gently insert the assembly into the grooves until the antigravity clutch is engaged (FIGURE 10-5).**
The antigravity clutch holds the assembly into position so that it can be released without the assembly sliding down into the system.
5. **Push down slowly at the center top of the assembly until the top face of the assembly is approximately three or four inches (7.5 cm to 10 cm) from the top of the chassis.**
6. **When the assembly is approximately three or four inches (7.5 cm to 10 cm) from the top of the chassis, change your grip and grasp the ejector levers so that they are oriented in the vertical position, 90 degrees straight out from the assembly.**



Caution – Metal pins on the underside of the ejector levers help to cushion the CPU/Memory board after the antigravity clutch is released. If the levers are not 90 degrees straight out from the top of the board there is a chance the connectors could be damaged.

7. **Complete the seating. Lower the assembly using the ejector levers until the levers are forced to approximately 45 degrees towards the inside of the assembly.**
8. **Reposition your grip on the levers and then push down on the levers to lock them into place.**
9. **Install the PCI cards.**
See [Section 10.2.2, “Installing a PCI Card”](#) on page 10-12.

10. Reconnect the I/O cables at the rear of the system.
11. Reconnect the I/O cables from the removable media modules to the IB_SSC assembly.
12. Close the removable media bay and PCI bay covers.
13. Remove the antistatic wrist.
14. Slide the system into the system cabinet and secure it.
See [Section 3.1, "Sliding the System Out of the System Cabinet"](#) on page 3-1.
15. Retract the system cabinet stabilizer bar.
16. Power on the system.
See [Section 4.1, "Powering On the System"](#) on page 4-1.

10.2 PCI Cards



Caution – This procedure requires the system to be extended out of the system cabinet on its slides. You must extend the system cabinet stabilizer bar.

PCI cards are located in the PCI bay ([FIGURE 10-6](#)).

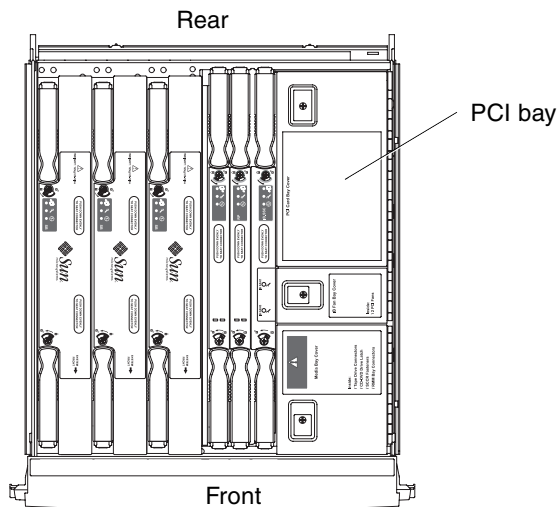

FIGURE 10-6 PCI Bay Location

10.2.1 Removing a PCI Card



Caution – If you remove a PCI card and are not going to replace it, you must fit a PCI card filler panel in its place to maintain EMI integrity.

1. Take the system to Standby mode.

See [Section 4.2, “Taking the System to Standby Mode”](#) on page 4-2.

2. Make sure that the leveling feet are extended to the floor.

3. Extend and lock the system cabinet stabilizer bar.

See [Section 3.1, “Sliding the System Out of the System Cabinet”](#) on page 3-1 and [Section 3.2, “Sliding the System Into the System Cabinet”](#) on page 3-5.



Caution – Failure to extend and lock the stabilizer bar before you slide a system out of the rack will cause the system cabinet to tip over.

4. Slide the system out of the system cabinet until the locking latches click.

See [Section 3.1, “Sliding the System Out of the System Cabinet”](#) on page 3-1.

5. Attach a wrist strap. Place a grounded ESD mat close to the system.

See [Section 2.8, “Antistatic Precautions”](#) on page 2-6.

6. Remove the appropriate PCI connector(s) from the rear of the system.

7. Open the PCI bay cover (FIGURE 10-7).

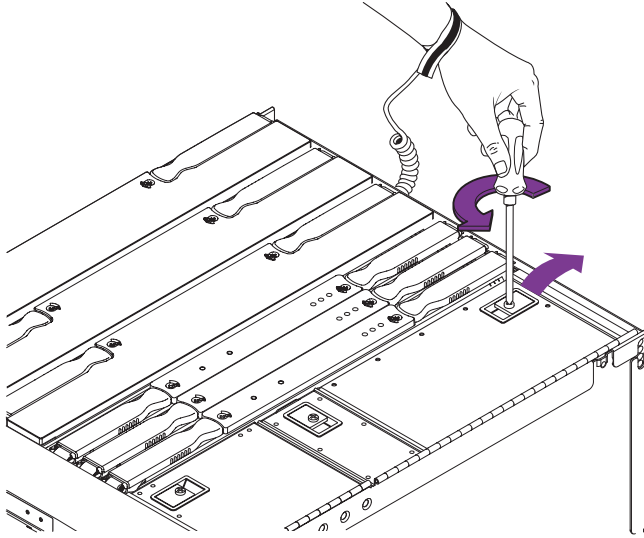

FIGURE 10-7 Opening the PCI Bay Cover

8. Identify the card to be removed.
9. Remove the retaining screw. Gently pull the card upward until it is free of the IB_SSC receptacle ([FIGURE 10-8](#) and [FIGURE 10-9](#)).

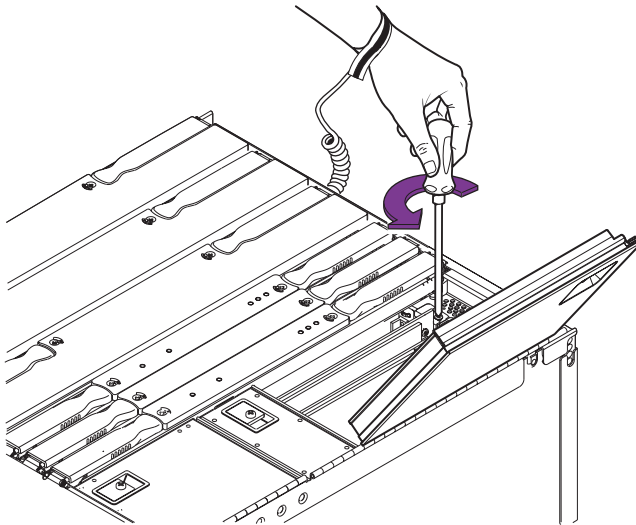

FIGURE 10-8 Removing the PCI Card Retaining Screw

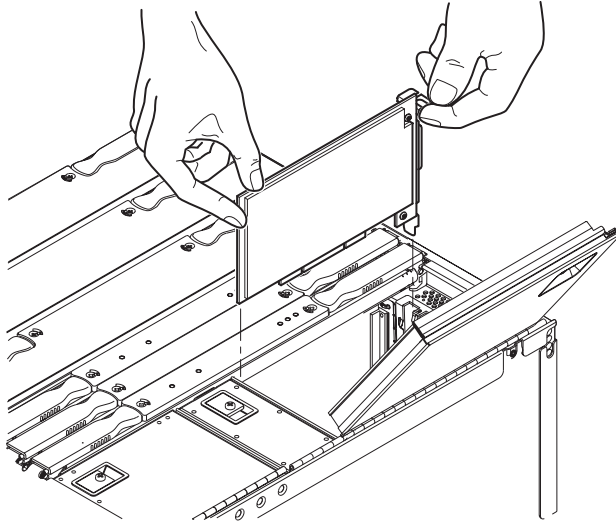

FIGURE 10-9 Removing a PCI Card

10. Place the PCI card on a grounded ESD mat.
11. If you are not going to install a PCI card, install a filler panel into the slot.
12. Close the PCI bay cover and secure it.
13. Reconnect the appropriate cable(s) into the PCI connector(s) at the rear of the system.
14. Remove the antistatic wrist strap.
15. Slide the system into the system cabinet and secure it.
See [Section 10.1, "IB_SSC Assembly" on page 10-1.](#)
16. Retract the system cabinet stabilizer bar.
17. Power on the system.
See [Section 4.1, "Powering On the System" on page 4-1.](#)

10.2.2 Installing a PCI Card



Caution – This procedure requires the system to be extended out of the system cabinet on its slides. You must extend the system cabinet stabilizer bar.

1. Take the system to Standby mode.

See [Section 4.2, “Taking the System to Standby Mode”](#) on page 4-2.

2. Make sure that the leveling feet are extended to the floor.

3. Extend and lock the system cabinet stabilizer bar.

See [Section 3.1, “Sliding the System Out of the System Cabinet”](#) on page 3-1 and [Section 3.2, “Sliding the System Into the System Cabinet”](#) on page 3-5.



Caution – Failure to extend and lock the stabilizer bar before you slide a system out of the system cabinet can cause the system cabinet to tip over.

4. Slide the system out of the system cabinet until the locking latches click.

See [Section 3.1, “Sliding the System Out of the System Cabinet”](#) on page 3-1.

5. Attach a wrist strap. Place a grounded ESD mat close to the system.

See [Section 2.8, “Antistatic Precautions”](#) on page 2-6.

6. Open the PCI bay cover.

7. Install the PCI card.

a. Remove the filler panel (if installed).

b. Press the card gently into the IB_SSC receptacle until it is fully seated. Secure the card with a retaining screw.

8. Close the PCI bay cover and secure it.

9. Connect the appropriate cable into the PCI connector at the rear of the system.

10. Remove the antistatic wrist strap.

11. Slide the system into the system cabinet and secure it.

See [Section 3.1, “Sliding the System Out of the System Cabinet”](#) on page 3-1.

12. Retract the system cabinet stabilizer bar.

13. Power on the system.

See [Section 4.1, “Powering On the System”](#) on page 4-1.

L2 Repeater Boards

This chapter explains how to remove and install an L2 Repeater board.

11.1 L2 Repeater Board



Caution – This procedure requires the system to be extended out of the system cabinet on its slides. You must extend the system cabinet stabilizer bar.

The system supports up to two L2 Repeater boards, RP0 and RP1, which are located at the top of the system ([FIGURE 11-1](#)).

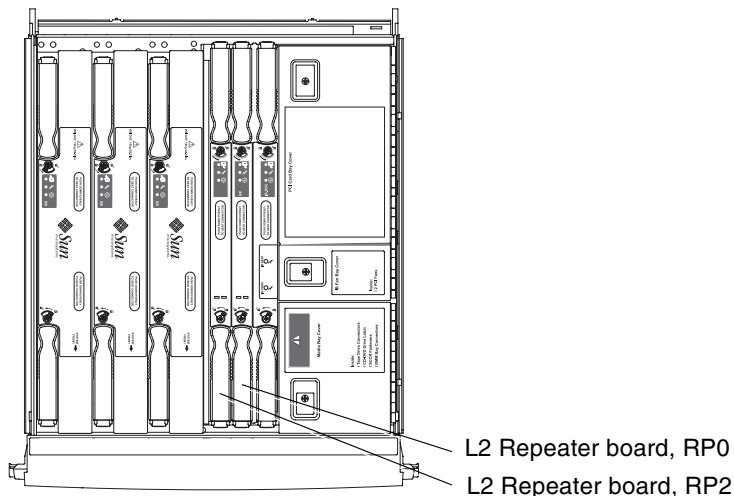





FIGURE 11-1 Location of Boards, Modules, and Bays—System Top View

There are three LEDs on the L2 Repeater board. [TABLE 11-1](#) lists the LED names and functions.

TABLE 11-1 L2 Repeater Board LED Functions

LED Name		On	Off
Activated LED (green)		Board is activated.	Board is deactivated.
Fault LED (amber)		Internal fault.	No internal fault.
OK to remove LED (blue or amber)		Board can be removed.	Board can not be removed.

11.1.1 Removing an L2 Repeater Board



Caution – Spring fingers and EMI gaskets may detach from the L2 Repeater board and fall into the system. This may cause damage. Make sure that the EMI gaskets and spring fingers do not fall into the system.

1. **Take the system to Standby mode.**
See [Section 4.2, “Taking the System to Standby Mode”](#) on page 4-2.
2. **Remove the four input power cables, AC0 through AC4 ([FIGURE 1-3](#)).**
This removes power to the system.
3. **Make sure that the leveling feet are extended to the floor.**
4. **Extend and lock the system cabinet stabilizer bar.**



Caution – Failure to extend and lock the stabilizer bar before you slide a system out of the rack will cause the system cabinet to tip over.

5. **Slide the system out of the system cabinet until the locking latches click.**
See [Section 3.1, “Sliding the System Out of the System Cabinet”](#) on page 3-1.
6. **Be sure that you have a replacement board ready.**
7. **Attach a wrist strap. Place a grounded ESD mat close to the system.**
See [Section 2.8, “Antistatic Precautions”](#) on page 2-6.

8. Unlock the ejector levers with a Phillips no. 2 screwdriver (FIGURE 11-2).
The ejectors will pop out slightly.

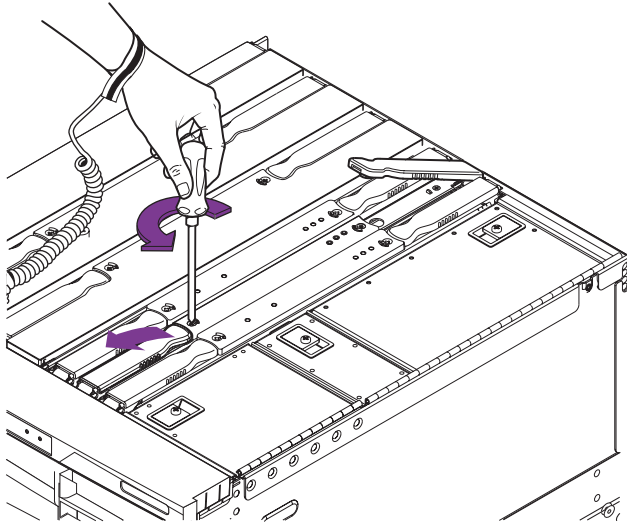

FIGURE 11-2 Unlocking the L2 Repeater Board Ejector Levers

9. If you are removing the L2 Repeater board next to the media bay, lift the cover to the media bay.
10. Raise the ejector levers simultaneously until they are 90 degrees straight out from the board.
This action unseats the board from the connector.
11. Grasp the ejector levers and pull upward to raise the L2 Repeater board until the green panels are visible (FIGURE 11-3).
The antigravity clutch holds the board in position so that it can be released without the board sliding down into the system.

Note – Any plastic green panels are parts that you can touch.

12. Grasp the green panels and raise the L2 Repeater board out of the system (FIGURE 11-3).

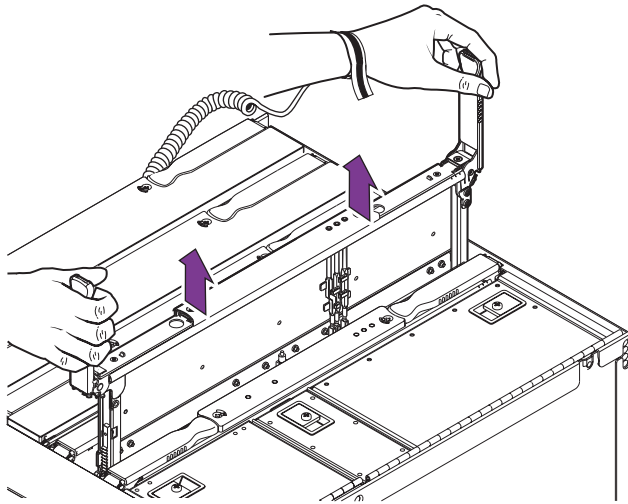

FIGURE 11-3 Raising an L2 Repeater Board

13. Place the board on a grounded ESD mat.

11.1.2 Installing the L2 Repeater Board



Caution – *Do not force* any board into a slot; it can cause damage to the board and system. The board should insert and seat smoothly. If it binds, remove the board and inspect the card cage slot for any obvious obstructions. Also inspect both the board and the baseplane for bent pins or other damage.



Caution – Ensure that the protective covering is removed from the replacement CPU/Memory board connectors prior to installation of the board or damage to the board and/or baseplane connectors can result.

1. Attach a wrist strap to your wrist. Connect the ESD wrist strap to the system.
See [Section 2.8, “Antistatic Precautions”](#) on page 2-6.
2. Visually inspect the connector(s) for damage.

3. Hold the green side panels and gently insert the L2 Repeater board into the grooves until the antigravity clutch is engaged.

The antigravity clutch holds the board in position so that it can be released without the board sliding down into the system.

4. Slowly push down from the center top of the L2 Repeater board until the top face of the board is approximately three or four inches (7.5 cm to 10 cm) from the top of chassis.
5. When the board is approximately three or four inches (7.5 cm to 10 cm) from the top of the chassis, change your grip and grasp the ejector levers so that they are oriented in the vertical position, 90 degrees straight out from the board.



Caution – Metal pins on the underside of the ejector levers help to cushion the CPU/Memory board after the antigravity clutch is released. If the levers are not 90 degrees straight out from the top of the board, there is a chance the connectors could be damaged.

6. To complete the seating, lower the board using the ejector levers until the levers are forced approximately 45 degrees toward the inside of the board.
7. Reposition your grip on the levers and then push down on the levers to lock them into place (FIGURE 11-3).

You can release the levers when the board is inserted halfway in order to change your grip.

8. Remove the wrist strap.
9. Slide the system back into the chassis and secure it.
See [Section 3.1, “Sliding the System Out of the System Cabinet”](#) on page 3-1.
10. Retract the system cabinet stabilization bar.
11. Replace the four input power cables, AC0 through AC4 (FIGURE 1-3 and TABLE 1-1).
12. Power on the system.

See [Section 4.1, “Powering On the System”](#) on page 4-1.

System Indicator Board

This chapter describes how to remove and install the system indicator board. This chapter contains the following topics:

- [Section 12.1, “System Indicator Board” on page 12-1](#)
 - [Section 12.1.1, “Removing the System Indicator Board” on page 12-2](#)
 - [Section 12.1.2, “Installing the System Indicator Board” on page 12-4](#)

12.1 System Indicator Board

The system indicator board is an indicator panel with various system LEDs and the On/Standby switch ([FIGURE 12-1](#)).



FIGURE 12-1 System Indicator Board LEDs

To remove and replace the board, you must power off the system.

12.1.1 Removing the System Indicator Board



Caution – Use proper ESD grounding techniques when handling components. Wear an antistatic wrist strap and use an ESD-protected mat. Store ESD-sensitive components in its ESD safe packaging box before placing them on any surface.

1. **Take the system to Standby mode.**
See [Section 4.2, “Taking the System to Standby Mode”](#) on page 4-2.
2. **Remove the four input power cables, AC0 through AC4 (FIGURE 1-3).**
This action removes power to the system.
3. **Make sure that the leveling feet are extended to the floor.**
4. **Extend and lock the system cabinet stabilization bar.**



Caution – Failure to extend and lock the stabilizer bar before you slide a system out of the system cabinet can cause the system cabinet to tip over.

5. **Slide the system out of the system cabinet until the locking latches click.**
See [Section 3.1, “Sliding the System Out of the System Cabinet”](#) on page 3-1.
6. **Open the front doors to the system.**
7. **Attach a wrist strap. Place a grounded ESD mat close to the system.**
See to [Section 2.8, “Antistatic Precautions”](#) on page 2-6.
8. **Open the media bay access door.**

9. Press in the back of the system indicator board plastic housing. Push very hard on the plastic latching clips to release the upper housing from the lower housing (FIGURE 12-2).

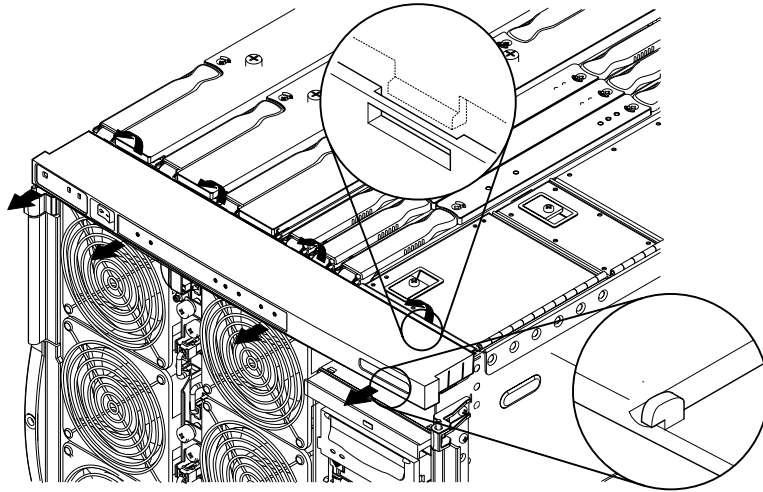

FIGURE 12-2 Removing the System Indicator Board Cover

10. Remove the clip on the fan tray retaining the system indicator board connector. Remove the connector (FIGURE 12-3).

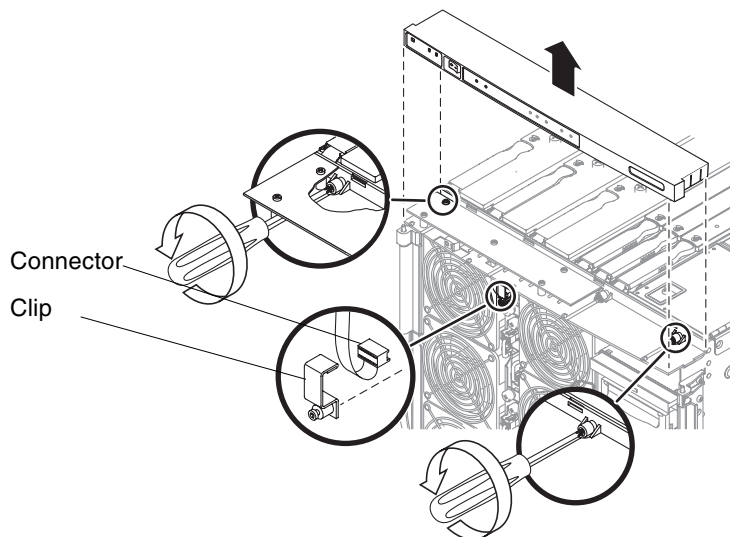

FIGURE 12-3 Removing the System Indicator Board Clip and Connector

11. Loosen the two captive screws securing the indicator board to the top of the chassis ([FIGURE 12-3](#)).
12. Remove the module and place it on an ESD mat ([FIGURE 12-3](#)).

12.1.2 Installing the System Indicator Board



Caution – Use proper ESD grounding techniques when handling components. Wear an antistatic wrist strap and use an ESD-protected mat. Store ESD-sensitive components in its ESD safe packaging box before placing them on any surface.

1. **Attach a wrist strap. Place a grounded ESD mat close to the system.**
See to [Section 2.8, “Antistatic Precautions”](#) on page 2-6.
2. **Secure the indicator board using the two captive screws ([FIGURE 12-3](#)).**
3. **Connect the indicator board connector to the receptacle at the top of the fan tray. Replace the retaining clip ([FIGURE 12-3](#)).**
4. **Push hard on the back of the system indicator board housing onto the chassis until the plastic latching clips engage ([FIGURE 12-2](#)).**
This action connects the upper housing to the lower housing.
5. **Close the front doors to the system.**
6. **Retract the system cabinet stabilization bar.**
7. **Remove the wrist strap.**
8. **Replace the four input power cables, AC0 through AC4 ([FIGURE 1-3](#) and [TABLE 1-1](#)).**
9. **Power on the system.**
See [Section 4.1, “Powering On the System”](#) on page 4-1.

Baseplane

This chapter describes how to remove and replace the baseplane, which is located at the bottom of the system (FIGURE 13-1).

13.1 Baseplane Overview and Cautions



Caution – Use proper ESD grounding techniques when handling components. Wear an antistatic wrist strap and use an ESD-protected mat. Store ESD-sensitive components in its ESD safe packaging box before placing them on any surface.



Caution – This procedure requires the system to be extended out of the system cabinet on its slides. You must extend the system cabinet stabilization bar.

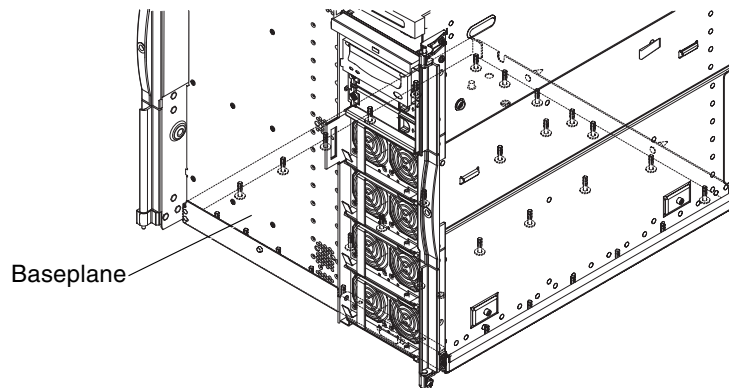

FIGURE 13-1 Baseplane Location in the System

13.1.1 Removing the Baseplane

1. **Take the system to Standby mode.**
See [Section 4.2, "Taking the System to Standby Mode"](#) on page 4-2.
2. **Remove the four input power cables, AC0 through AC4 (FIGURE 1-3).**
This action removes power to the system.
3. **Make sure that the leveling feet are extended to the floor.**
4. **Extend and lock the system cabinet stabilization bar.**
See [Section 3.1, "Sliding the System Out of the System Cabinet"](#) on page 3-1 and [Section 3.2, "Sliding the System Into the System Cabinet"](#) on page 3-5.



Caution – Failure to extend and lock the stabilizer bar before you slide a system out of the rack will cause the system cabinet to tip over.

5. **Prepare ESD surfaces to place the boards and components you will remove.**
The fan tray, IB_SSC assembly, and power distribution board will need a large amount of space.
6. **Slide the system out of the system cabinet until the locking latches click.**
See ["Sliding the System Out of the System Cabinet"](#) on page 3-1.
7. **Attach a wrist strap.**
See [Section 2.8, "Antistatic Precautions"](#) on page 2-6.
8. **Remove and label the PCI cables.**
9. **Remove and label the power cables.**
10. **Open the front doors.**
11. **Remove the main fan tray located at the front of the system.**
See [Section 7.2.1, "Removing the Main Fan Tray"](#) on page 7-7.
12. **Unseat all of the power supplies.**
[Section 8.1.1, "Removing a Power Supply"](#) on page 8-3.
13. **From the right of the system, remove the IB_SSC board. Do not remove the PCI cards.**
See [Section 10.1.1, "Removing the IB_SSC Assembly"](#) on page 10-2.

Note – Completely remove the IB_SSC assembly is necessary in order to remove the power distribution board.

14. Remove the power distribution board.

See [Section 8.3.1, “Removing the Power Distribution Board”](#) on page 8-6.

15. Disengage and raise the following boards at least two inches above the system, but *do not* completely remove them:

- CPU/Memory boards

See [Section 9.2.1, “Removing a CPU/Memory Board”](#) on page 9-4.

- L2 Repeater boards

See [Section 11.1.1, “Removing an L2 Repeater Board”](#) on page 11-2.

16. From beneath the system, loosen 30 of the 31 captive screws securing the baseplane to the chassis (FIGURE 13-2). Leave the screw at the center of the front secured.

Use a Phillips no. 2 short stubby (or 6-inch, 15 cm) screwdriver if the system is in a low mounting location in the system cabinet.

17. Completely loosen the centerplane from the system.

There are two different baseplane designs:

- With a plunger (release button) securing it at the front
- Without a plunger

If a plunger is fitted, remove it when instructed to do so in [Step 20](#). The plunger binds with CPU/Memory board, SB0, during installation and may cause connector damage.

- If the system does not have a plunger (release button), loosen the center front screw ([FIGURE 13-2](#)). Keep one hand under the baseplane while loosening the center front screw. Go to [Step 18](#).
- If the system has a plunger (release button), with one hand, hold the baseplane up and press in the plunger (release button) at the front of the chassis ([FIGURE 13-3](#)).



Caution – The baseplane is heavy. Be ready to take its weight to prevent risk of injury.

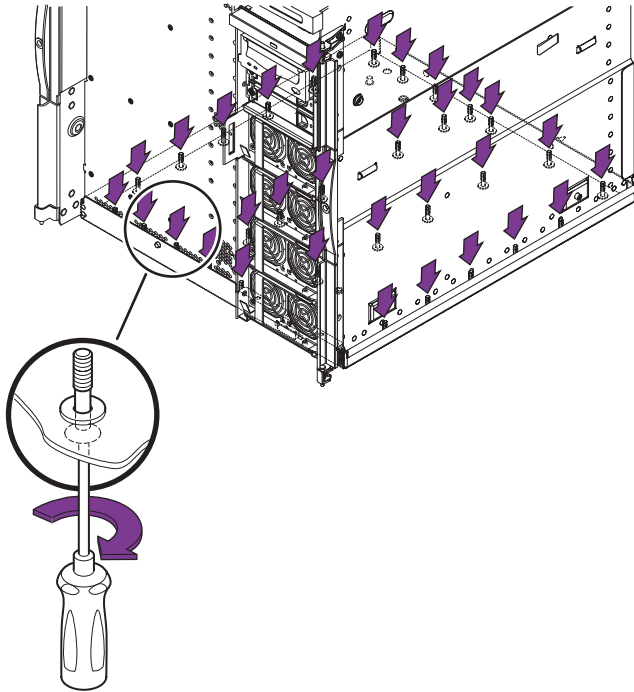

FIGURE 13-2 Removing the Baseplane Securing Screws

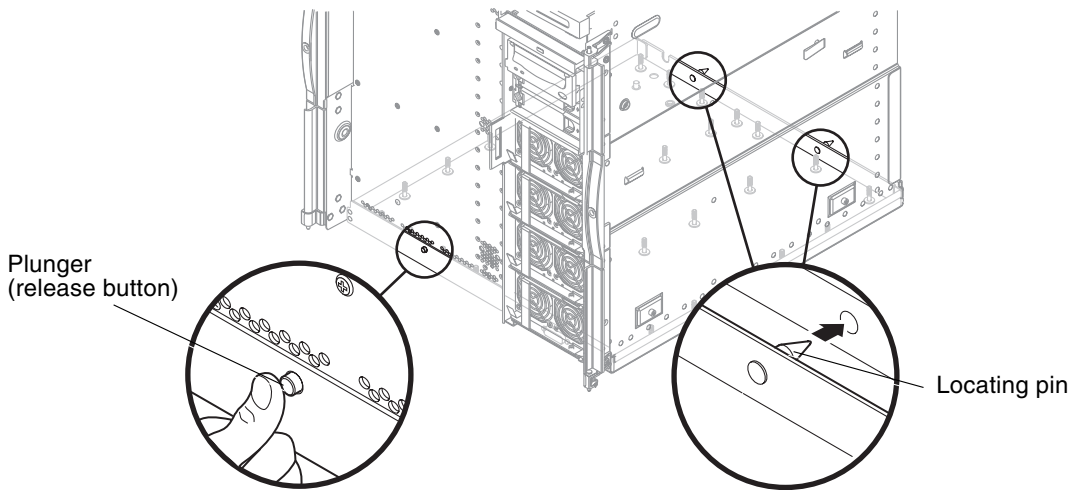

FIGURE 13-3 Releasing the Baseplane Plunger (If Fitted)

18. Lower the front of the baseplane and pull it forward (FIGURE 13-3).
This action releases the locating pins from the slots at the rear of the chassis.
19. Remove the baseplane and place it on an ESD mat (FIGURE 13-4).

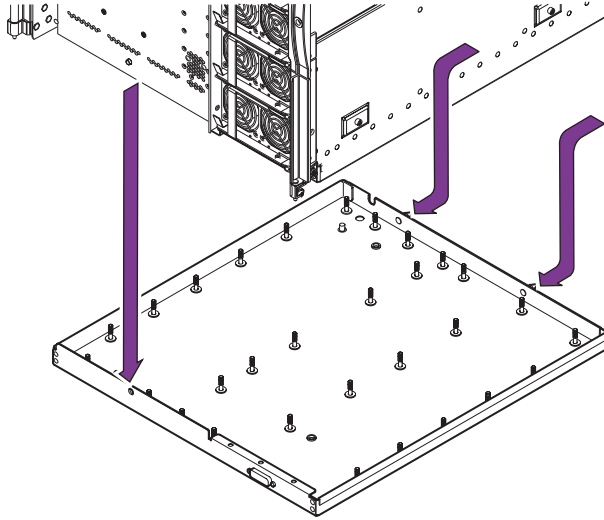

FIGURE 13-4 Removing the Baseplane

20. Locate the plunger (release button) attachment (threaded collar) on the outside of the chassis. The threaded collar has two flattened edges to grip.
 - a. Using pliers, unfasten the threaded collar from the plunger.
 - b. Remove the plunger (release button) from inside the system.

13.1.2 Installing the Baseplane

1. Attach a wrist strap. Place grounded ESD mats close to the system.
See [Section 2.8, "Antistatic Precautions"](#) on page 2-6.
2. Orient the baseplane with the locating pins to the rear.
3. Insert the locating pins into the slots at the rear of the chassis (FIGURE 13-3).
4. Raise the front of the baseplane. Tighten the center front screw first while supporting the weight of the baseplane with your other hand.
5. Tighten the 30 captive screws beneath the baseplane.

6. **Install or re-engage the assemblies and boards in the following order:**
 - a. **Seat the CPU/Memory boards and L2 Repeater boards.**

See [Section 9.2.2, "Installing a CPU/Memory Board"](#) on page 9-8 and [Section 11.1.2, "Installing the L2 Repeater Board"](#) on page 11-4.
 - b. **Install the power distribution board.**

See [Section 8.3.2, "Installing the Power Distribution Board"](#) on page 8-8.
 - c. **From the right of the system, install the IB-SSC assembly.**
 - d. **Reseat all power supplies.**

See [Section 8.1.2, "Installing a Power Supply"](#) on page 8-4.
 - e. **Install the main fan tray.**

See [Section 7.2.2, "Installing the Main Fan Tray"](#) on page 7-10.
 - f. **At the rear of the system, reconnect the PCI cables and the power cables.**
7. **Remove the wrist strap.**
8. **Slide the system into the system cabinet and secure it.**

See [Section 3.1, "Sliding the System Out of the System Cabinet"](#) on page 3-1.
9. **Retract the system cabinet stabilization bar.**
10. **Reconnect the four input power cables, AC0 through AC4 ([FIGURE 1-3](#) and [TABLE 1-1](#)).**
11. **Power on the system.**

See [Section 4.1, "Powering On the System"](#) on page 4-1.

Antigravity Clutches

There are antigravity clutches on the system for CPU/Memory boards, IB_SSC assemblies, and L2 Repeater boards. This chapter explains how to replace clutches for these boards and assemblies. This chapter describes how to remove and replace a clutch.



Caution – Use proper ESD grounding techniques when handling components. Wear an antistatic wrist strap and use an ESD-protected mat. Store ESD-sensitive components in its ESD safe packaging box before placing them on any surface.



Caution – This procedure requires the system to be extended out of the system cabinet on its slides. You must extend the system cabinet stabilization bar.

14.1 Clutch

The replacement antigravity clutch kit contains three different types of clutches, one for each type of FRU. They can be identified by their part numbers, which are listed in the *Sun System Handbook*.

- L2 Repeater board
- CPU/Memory board
- IB_SSC assembly

All antigravity clutch replacements are installed in the same way.

14.1.1 Clutch Locations

FIGURE 14-1 shows the location of the clutch for the L2 Repeater board.

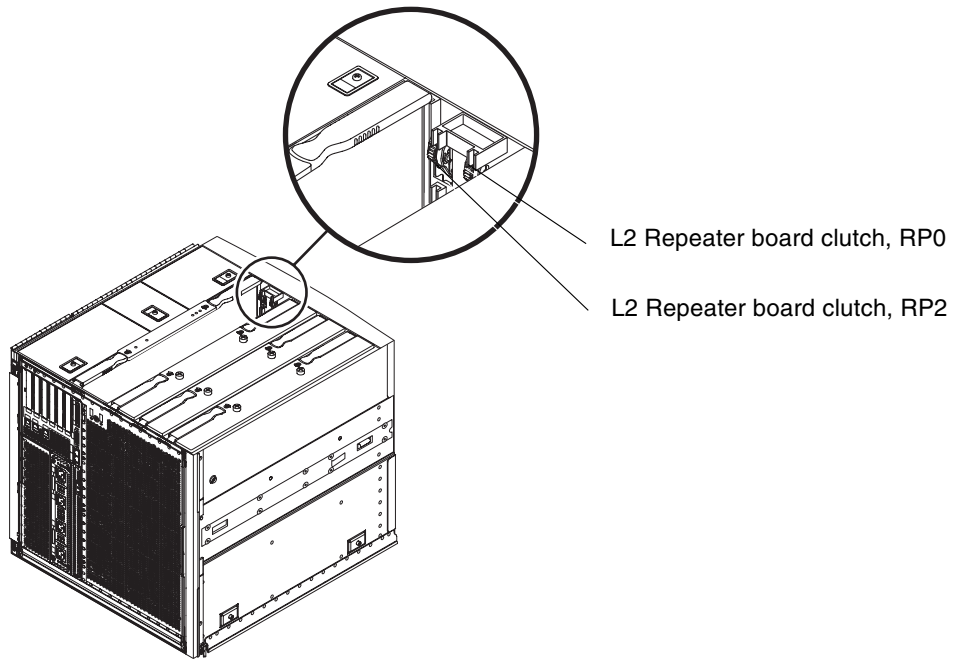

FIGURE 14-1 L2 Repeater Board Clutch Location

FIGURE 14-2 shows the location of the clutch for the CPU/Memory board.

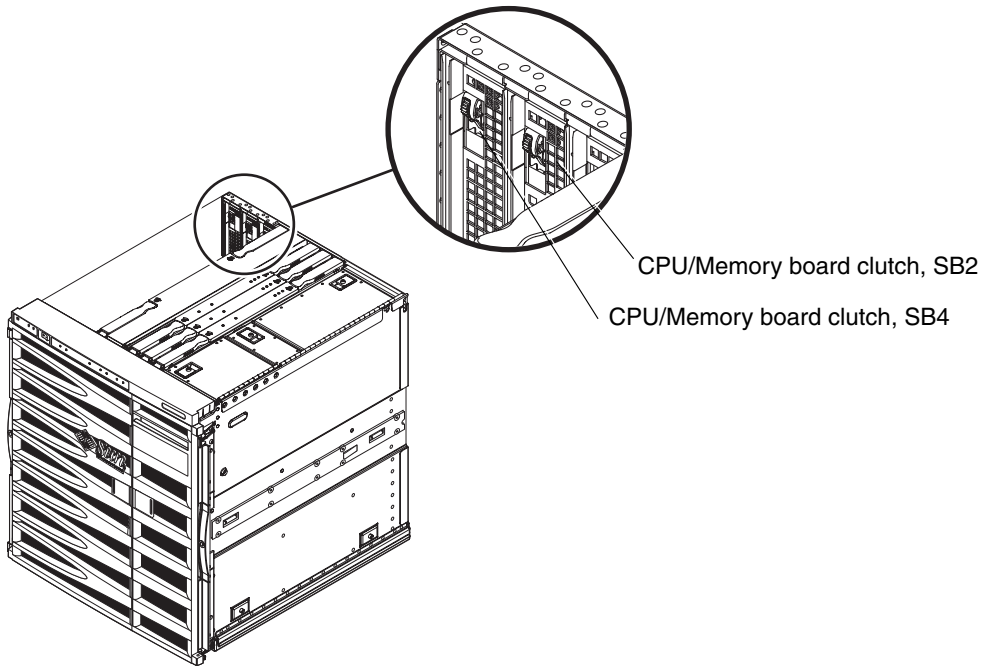

FIGURE 14-2 CPU/Memory Board Clutch Locations

FIGURE 14-3 shows the location of the clutch for the IB_SSC assembly.

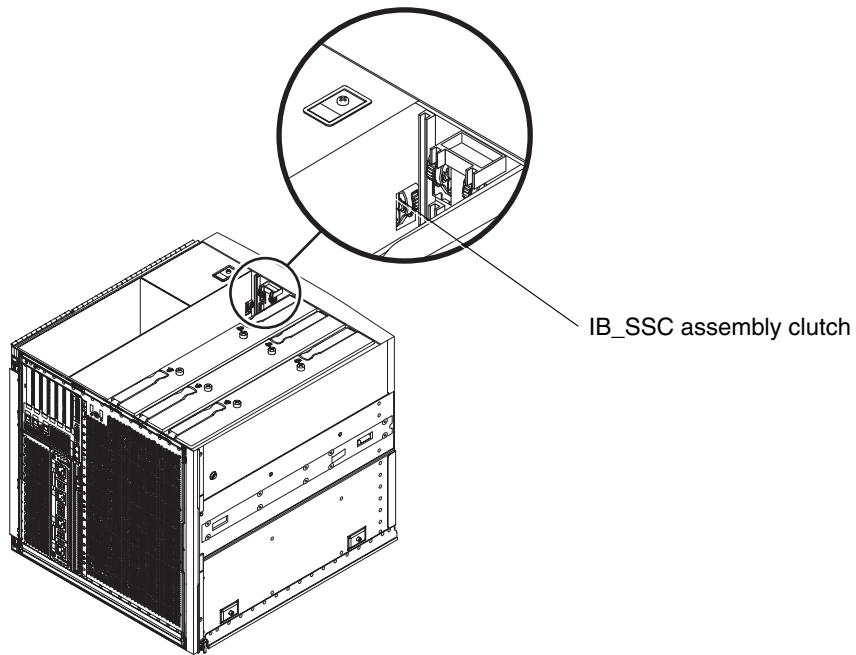

FIGURE 14-3 IB_SSC Assembly Clutch Location

14.1.2 Replacing a Clutch

To replace a clutch, IB_SSCCPU/Memory board, L2 Repeater board, or IB_SSC board clutch, follow these steps:

1. Take the system to Standby mode.

See [Section 4.2, “Taking the System to Standby Mode”](#) on page 4-2.

2. If you are replacing an L2 Repeater board or IB_SSC board clutch, remove power to the system by removing the four input power cables, AC0 through AC4 (FIGURE 1-3).

3. Make sure that the leveling feet are extended to the floor.

4. Extend and lock the system cabinet stabilizer bar.

See [Section 3.1, “Sliding the System Out of the System Cabinet”](#) on page 3-1 and [Section 3.2, “Sliding the System Into the System Cabinet”](#) on page 3-5.



Caution – Failure to extend and lock the stabilizer bar before you slide a system out of the system cabinet can cause the system cabinet to tip over.

5. Slide the system out of the system cabinet until the locking latches click.

See [“Sliding the System Out of the System Cabinet”](#) on page 3-1.

6. Attach the ESD wrist strap. Place a grounded ESD mat close to the system.

See [Section 2.8, “Antistatic Precautions”](#) on page 2-6.

7. Remove the board or assembly from the slot with the defective clutch.

See one of the following sections:

- [Section 9.2.1, “Removing a CPU/Memory Board”](#) on page 9-4
- [Section 10.1.1, “Removing the IB_SSC Assembly”](#) on page 10-2
- [Section 11.1.1, “Removing an L2 Repeater Board”](#) on page 11-2

8. Remove the two screws retaining the faulty clutch. Remove the clutch.

9. Install the replacement clutch using the screws you removed. Secure it in the same position.

10. Replace the board you previously removed.

See one of the following sections:

- [Section 9.2.2, “Installing a CPU/Memory Board” on page 9-8](#)
- [Section 10.1.2, “Installing the IB_SSC Assembly” on page 10-7](#)
- [Section 11.1.2, “Installing the L2 Repeater Board” on page 11-4.](#)

11. Remove the antistatic wrist strap.

12. Slide the system into the system cabinet and secure it.

See [Section 3.1, “Sliding the System Out of the System Cabinet” on page 3-1.](#)

13. Retract the system cabinet stabilization bar.

14. Reconnect the four input power cables, AC0 through AC4 ([FIGURE 1-3](#) and [TABLE 1-1](#)).

15. Power on the system.

See [Section 4.1, “Powering On the System” on page 4-1.](#)

Side Handles

This chapter describes how to remove and replace the side handles.

15.1 Replacing the Handles



Caution – This procedure requires the system to be extended out of the system cabinet on its slides.

1. Take the system to Standby mode.

See [Section 4.2, “Taking the System to Standby Mode”](#) on page 4-2.

2. Make sure that the leveling feet are extended to the floor.

3. Extend and lock the system cabinet stabilizer bar.

See [Section 3.1, “Sliding the System Out of the System Cabinet”](#) on page 3-1 and [Section 3.2, “Sliding the System Into the System Cabinet”](#) on page 3-5.



Caution – Failure to extend and lock the stabilizer bar before you slide a system out of the rack will cause the system cabinet to tip over.

4. Slide the system out of the system cabinet until the locking latches click.

See [“Sliding the System Out of the System Cabinet”](#) on page 3-1.

5. Remove the appropriate front bezel door (FIGURE 15-1). Release the two hinges on each section of the bezel by pressing down on the hinge pin levers.

This action releases the hinge pins.

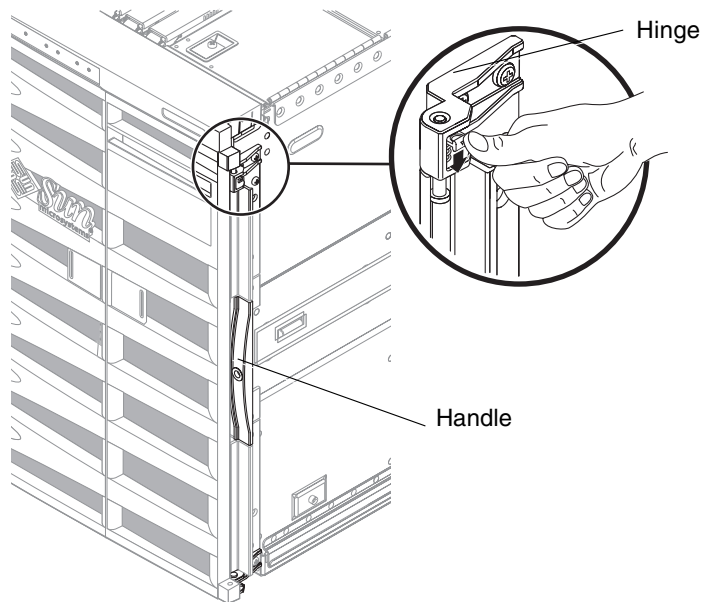

FIGURE 15-1 Bezel Hinge Release Mechanism

- 6. Remove the four Phillips no. 2 screws securing the handle.**
- 7. Attach the new handle using the four screws you removed in [Step 6](#).**
- 8. Replace the door.**
- 9. Slide the system back into the system cabinet and secure it.**
See [Section 3.2, "Sliding the System Into the System Cabinet"](#) on page 3-5.
- 10. Retract the system cabinet stabilization bar.**
- 11. Power on the system.**
See [Section 4.1, "Powering On the System"](#) on page 4-1.

Parts List

This chapter describes the availability of FRUs and options for the Sun Fire E2900 system.

Some of the FRUs and options can be installed by a competent system administrator, but many *must* be installed by an appropriately qualified service engineer, as shown in [TABLE A-1](#). For the latest FRU list and part numbers of each FRU, refer to the *Sun System Handbook*.

TABLE A-1 FRUs and Options

Description	Configuration	Can be installed by:	
		System Administrator	Qualified Service Engineer
CPU/Memory module			✓
Memory expansion (DIMMs)			✓
AC power cord kit		✓	✓
Cable management arm	CMA-Lite		✓
	CMA-800		✓
SCSI hard disk drive		✓	✓
DDS-4 tape drive			✓
DVD-ROM drive			✓
Environmental filter kit		✓	✓
Bezel kit		✓	✓
CPU/Memory filler board			✓
Tape drive blanking panel			✓
AC power supply		✓	✓

TABLE A-1 FRUs and Options (*Continued*)

Description	Configuration	Can be installed by:	
		System Administrator	Qualified Service Engineer
Power distribution board			✓
Baseplane			✓
System configuration card reader			✓
Media bay (includes SCSI backplane)			✓
L2 Repeater board			✓
IB_SSC assembly			✓
Main system fans			✓
System fan tray (includes 8 fans)			✓
IB fan			✓
Top bezel and system indicator board			✓
AC power inlet assembly			✓
DVD-ROM backplane			✓
System configuration card		✓	✓
Internal cable kit			✓
Antigravity clutch kit	CPU/Memory board		✓
	IB_SSC assembly		✓
	L2 Repeater board		✓
Rackmount slide kit			✓
Left front door/handle assembly			✓
Right front door/handle assembly			✓
IB_SSC internal foam baffle			✓

Connectors

This appendix describes the various cables and connectors that should be made available in order for the installation to be completed.

B.1 Sun Fire E2900 System Connectors

The Sun Fire E2900 system has the following connectors on the rear of the system:

- Two gigabit Ethernet RJ-45 ports
- Up to six PCI ports (5 x 33 MHz and 1 x 66 MHz)
- Two serial ports (one reserved)
- Alarms port
- 10/100 Ethernet port
- SCSI port

[FIGURE B-1](#) shows the locations of the ports and power inlets for the system. [TABLE B-1](#) describes the back panel ports and power inlets.

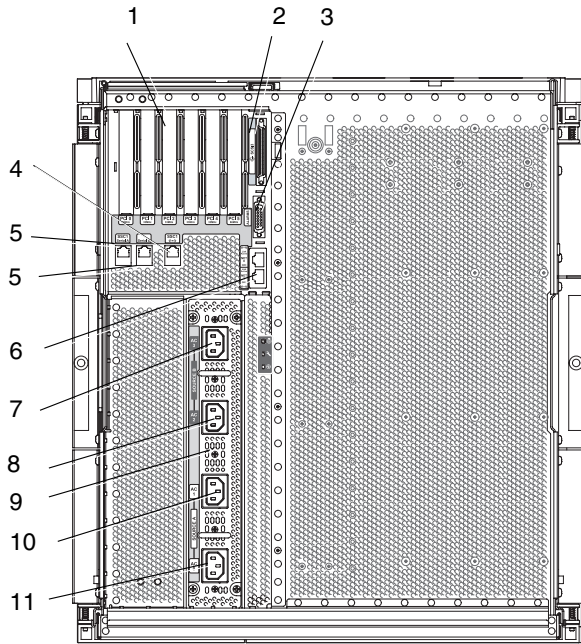

FIGURE B-1 Sun Fire E2900 System External I/O Connections

TABLE B-1 Sun Fire E2900 System Back Panel Legend

Number	Description
1	PCI0-PCI5 connectors
2	SCSI port, 68 pins
3	Alarms port
4	10/100 Ethernet LOM/system controller port
5	Serial ports
6	Net0/Net1 ports
7	AC3 input port
8	AC2 input port
9	AC power inlet box
10	AC1 input port
11	AC0 input port

B.2 Gigabit Ethernet Connectors

The gigabit Ethernet connectors are shielded RJ-45 connectors ([FIGURE B-2](#)). [TABLE B-2](#) lists the connector pinouts.

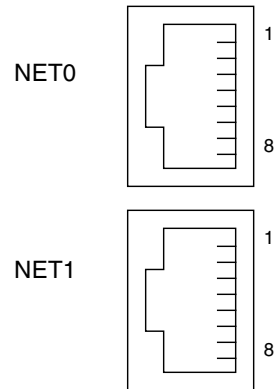

FIGURE B-2 RJ-45 Gigabit Ethernet Connectors

TABLE B-2 Gigabit Ethernet Connector Pinout

Pin	Signal Name	Pin	Signal Name
1	TRD0_H	5	TRD2_L
2	TRD0_L	6	TRD1_L
3	TRD1_H	7	TRD3_H
4	TRD2_H	8	TRD3_L

B.3 Serial Connectors

FIGURE B-3 illustrates the SSC RJ-45 serial connectors. Serial port B is reserved. TABLE B-3 describes the pinouts.

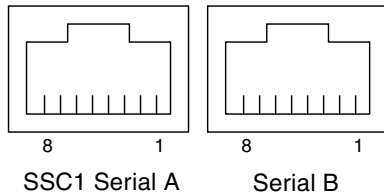

FIGURE B-3 RJ-45 Serial Connectors

TABLE B-3 RJ-45 Serial Connector Pinouts

Pin	Signal
1	RTS
2	DTR
3	TXD
4	Signal Ground
5	Signal Ground
6	RXD
7	DSR
8	CTS

B.4 SCSI Connector

FIGURE B-4 illustrates the 68-pin SCSI connector and the SCSI icon. TABLE B-4 describes the SCSI connector pinouts.

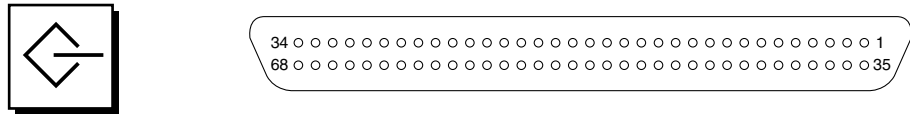

FIGURE B-4 68-Pin SCSI Connector

TABLE B-4 68-Pin SCSI Connector Pinouts

Pin No.	Signal Name	Type	Pin No.	Signal Name	Type	Pin No.	Signal Name	Type
1	+DB(12)	I/O	24	+ACK	I/O	47	-DB(7)	I/O
2	+DB(13)	I/O	25	+RST	I/O	48	-P_CRCA	I/O
3	+DB(14)	I/O	26	+MSG	I/O	49	Ground	GND
4	+DB(15)	I/O	27	+SEL	I/O	50	Ground	GND
5	+DB(P1)	I/O	28	+C/D	I/O	51	Termpwr	POWER
6	+DB(0)	I/O	29	+REQ	I/O	52	Termpwr	POWER
7	+DB(1)	I/O	30	+I/O	I/O	53	Reserved	NA
8	+DB(2)	I/O	31	+DB(8)	I/O	54	Ground	GND
9	+DB(3)	I/O	32	+DB(9)	I/O	55	-ATN	I/O
10	+DB(4)	I/O	33	+DB(10)	I/O	56	Ground	GND
11	+DB(5)	I/O	34	+DB(11)	I/O	57	-BSY	I/O
12	+DB(6)	I/O	35	-DB(12)	I/O	58	-ACK	I/O
13	+DB(7)	I/O	36	-DB(13)	I/O	59	-RST	I/O
14	+P_CRCA	I/O	37	-DB(14)	I/O	60	-MSG	I/O
15	Ground	GND	38	-DB(15)	I/O	61	-SEL	I/O
16	Diffsens	ANAL	39	-DB(P1)	I/O	62	-C/D	I/O
17	Termpwr	POWER	40	-DB(0)	I/O	63	-REQ	I/O
18	Termpwr	POWER	41	-DB(1)	I/O	64	-I/O	I/O
19	Reserved	NA	42	-DB(2)	I/O	65	-DB(8)	I/O
20	Ground	GND	43	-DB(3)	I/O	66	-DB(9)	I/O

TABLE B-4 68-Pin SCSI Connector Pinouts (*Continued*)

Pin No.	Signal Name	Type	Pin No.	Signal Name	Type	Pin No.	Signal Name	Type
21	+ATN	I/O	44	-DB(4)	I/O	67	-DB(10)	I/O
22	Ground	GND	45	-DB(5)	I/O	68	-DB(11)	I/O
23	+BSY	I/O	46	-DB(6)	I/O			

Note – All signals shown in [TABLE B-4](#) are active low.

B.4.1 SCSI Implementation

Following are the Fast-160 SCSI (UltraSCSI) features:

- SCSI Fast-160 (UltraSCSI) low-voltage differential parallel interface
 - 16-bit SCSI bus
 - 160-Mbps data transfer rate
- Support for 16 SCSI addresses:
 - Target 0 to 6 and 8 to F used for devices
 - Target 7 reserved for SCSI host adapter on main logic board
- Support for up to three internal SCSI devices (plus the host adapter) (on a second SCSI bus):
 - Disk 0[0]
 - Disk 1[1]
 - Tape [5]
- Maximum cable length 25 meters (terminator to terminator) for low-voltage differential, point-to-point interconnect

B.5 10/100 LOM/System Controller Ethernet Connector

[FIGURE B-5](#) illustrates the RJ-45 system controller and Ethernet connector and its icon. [TABLE B-5](#) describes the pinouts for the twisted-pair Ethernet connector.



FIGURE B-5 RJ-45 Twisted-Pair Ethernet Socket

TABLE B-5 Twisted-Pair Ethernet Connector Pinouts

Pin	Description	Pin	Description
1	TXD+	5	Common mode termination
2	TXD-	6	RXD-
3	RXD+	7	Common mode termination
4	Common mode termination	8	Common mode termination

B.5.1 Twisted-Pair Ethernet Cable-Type Connectivity

The following types of twisted-pair Ethernet cables can be connected to the 8-pin twisted pair Ethernet connector.

For 10BASE-T applications:

- Use a shielded twisted-pair (STP) cable ([TABLE B-6](#)):
 - Category 3 (STP-3, *voice* grade)
 - Category 4 (STP-4)
 - Category 5 (STP-5, *data* grade)

For 100BASE-T applications:

- Use shielded twisted-pair category 5 (STP-5, *data* grade) cable ([TABLE B-6](#)).

TABLE B-6 Cable Lengths for Twisted-Pair Ethernet and Shielded Twisted-Pair Ethernet Cables

Cable Type	Application(s)	Max Length (Metric)	Max Length (Imperial)
Shielded twisted-pair category 5 (STP-5, <i>data</i> grade)	10BASE-T	1000 m	3282 ft
Shielded twisted-pair category 5 (STP-5, <i>data</i> grade)	100BASE-T	100 m	327 ft

B.6 Alarms Port

The alarms service port connector (FIGURE B-6) is a male DB-15 connector. TABLE B-7 lists the pinouts.

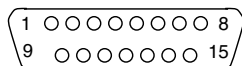

FIGURE B-6 DB-15 (Male) Alarms Service Port Connector

TABLE B-7 DB-15 (Male) Alarms Service Port Connector

Pin	Signal Name	Description	State
1	Not connected		
2	Not connected		
3	Not connected		
4	Not connected		
5	SYSTEM_NO	UNIX Running	Normally open
6	SYSTEM_NC	UNIX Running	Normally closed
7	SYSTEM_COM	UNIX Running	Common
8	SYSTEM_NO	Alarm1	Normally open
9	SYSTEM_NC	Alarm1	Normally closed
10	SYSTEM_COM	Alarm1	Common
11	ALARM2_NO	Alarm2	Normally open
12	ALARM2_NC	Alarm2	Normally closed
13	ALARM2_COM	Alarm2	Common
14	Not connected		
15	Not connected		

Glossary

cable management arm	
(CMA)	Supports and protects cables when a system slides into or out of a cabinet. There are two styles of CMAs: CMA-Lite and CMA-800.
CMA	See cable management arm.
dynamic reconfiguration	Part of the Solaris OS. Use dynamic reconfiguration to do the following tasks while the Solaris OS is running: reconfigure, remove, or install boards; display a board's operational status; invoke a board's hardware-specific functions; disable a device; reconfigure a domain; initiate system tests.
filler board	A board that is physically inserted into a board slot after a board is removed from the system. A filler board is used for EMI protection, air flow, and to prevent the system from overheating.
FRU	Field-replaceable unit or replacement part.
IB	Interface board containing the I/O assembly.
OpenBoot firmware	Executed immediately after you turn on the system. The primary tasks include: testing and initializing the system, determining system hardware, booting the operating system, and debugging.
plinth	See shipping cradle.
retention nut and washer	A retention washer and nut must be installed on the bolt of each slide rail before transporting a system cabinet containing installed systems.
SCC	System configuration card.
shipping cradle	Used to transport the system from one system cabinet to another system cabinet (also referred to as a plinth).
SSC	System controller.

**SunSolve Online
service** Informational and patch database service.

**system controller
software** The application that performs all of the system controller configuration functions.

Index

A

- antigravity clutch, replacing, 14-1
- antistatic precautions, 2-6
- antistatic wrist strap, attaching, 2-7

B

- baseplane
 - installing, 13-5
 - removing, 13-2
- board
 - baseplane, 13-1
 - CPU/Memory, 9-3
 - IB_SSC, 10-1
 - Level 2 Repeater, 11-2
 - system indicator, 12-1
- board handling, 2-5

C

- cabinet
 - sliding system out, 3-2, 3-5
- cable management arm, 5-1
- calbe management arm, 5-1
- clutch
 - IB_SSC assembly, replacing, 14-5
 - L2 Repeater board, replacing, 14-5
- clutch replacing, 14-1
- CMA, 5-1
- CMA-800

- installing and removing, 5-3
- CMA-Lite, 5-1, 5-2
- configuration guidelines
 - DIMMs, 9-12
- connectivity, TPE, B-7
- connectors, I/O, B-1
- cooling and power issues, CPU/Memory board, 9-1
- CPU/Memory board
 - components, 9-3
 - cooling and power issues, 9-1
 - description, 9-3
 - filler board, 9-2, 9-4
 - LEDs, 9-4
 - replacing, 9-4

D

- DAT tape drive
 - installing, 6-12
 - removing, 6-11
- DIMMs, 9-12, 9-15
 - configuration guidelines, 9-12
 - installing, 9-15
 - location, 9-11
 - maximizing performance, 9-15
 - removing, 9-13
 - replacing, 9-12
 - slot numbers, 9-11
- disk drive
 - installing, 6-4
 - removing, 6-2

- disk drive LEDs, 6-2
- Dual inline memory modules. *see* DIMMs, 9-11
- DVD-ROM drive
 - backplane, replacing, 6-16
 - replacing, 6-14

E

- Electrostatic discharge, *see* ESD, 2-2
- ESD, 2-2
- Ethernet, TPE connectivity, B-7

F

- fan LED, 7-2
- fan tray assembly, troubleshooting, 1-7
- fan tray, main
 - installing, 7-10
 - LEDs, 7-7
 - removing, 7-7
- fan, IB
 - installing, 7-14
 - removing, 7-12
- fan, main
 - installing, 7-6
 - removing, 7-4
- fault isolation tools, 1-8
- filler board
 - CPU/Memory board, 9-2, 9-4
- filler boards, 2-6
- filler panels, 2-6
- FRU list, A-1

H

- handle, side
 - replacing, 15-1
- handling boards, 2-5
- hard disk drive
 - installing, 6-4
 - removing, 6-2
- hard disk drive LEDs, 6-2

I

- I/O connections, B-1
- IB fan
 - installing, 7-14
 - removing, 7-12, 7-14
- IB_SSC assembly
 - clutch, replacing, 14-5
 - installing, 10-7
 - LEDs, 10-2
 - removing
- installing, 6-12
 - baseplane, 13-5
 - clutch, CPU/Memory board, 14-5
 - clutch, IB_SSC assembly, 14-5
 - clutch, L2 Repeater board, 14-5
 - CPU/Memory board, 9-8
 - CPU/Memory filler board, 9-2
 - DIMMs, 9-15
 - disk drive, 6-4
 - DVD-ROM backplane, 6-18
 - DVD-ROM drive, 6-16
 - IB fan, 7-14
 - IB_SSC assembly, 10-7
 - L2 Repeater board, 11-5
 - main fan, 7-6
 - main fan tray, 7-10
 - memory modules, 9-15
 - PCI card, 10-12
 - power distribution board, 8-8
 - power inlet box, 8-6
 - power supply, 8-4
 - removable media module, 6-10
 - SCC reader, 6-21
 - side handle, 15-1
 - system indicator board, 12-4
 - tape drive, 6-12
- isolating faults, 1-8

L

- L2 Repeater board
 - clutch, replacing, 14-5
 - installing, 11-4
 - location, 11-1
 - removing, 11-2
- LEDs
 - CPU/Memory board, 9-4

- disk drive, 6-2
- fan, 7-2
- FRUs, 1-6
- IB_SSC assembly, 10-2
- main fan tray, 7-6
- power supply, 8-2

Level 2 Repeater board, 11-2

M

memory modules

- configuration guidelines, 9-12
- DIMMs, 9-12, 9-15
- installing, 9-15
- location, 9-11
- maximizing performance, 9-15
- removing, 9-13
- replacing, 9-12
- slot numbers, 9-11

O

On/Standby switch, 4-3

- preventing accidental operation, 4-4

OpenBoot PROM firmware, 1-8

options, A-1

P

parts list, A-1

PCI card

- installing, 10-12
- removing, 10-9

PDB, *See power distribution board*

pinouts, I/O, B-1

plinth, 3-5

power distribution board

- installing, 8-8
- removing, 8-6

power distribution system, troubleshooting, 1-6

power inlet box, 8-5

- installing, 8-6
- removing, 8-5

power supply

- installing, 8-4
- LEDs, 8-2
- removing, 8-3

powering down system, *see Standby mode*, 4-2

powering on system, 4-1

precautions

- antistatic, 2-6
- safety, 2-2
- system, 2-4

PSU, *See power supply*

R

rack

- sliding system out, 3-2, 3-5

removable media module

- installing, 6-10
- removing, 6-6

removing, 8-5

- baseplane, 13-2
- clutch, CPU/Memory board, 14-5
- clutch, IB_SSC assembly, 14-5
- clutch, L2 Repeater board, 14-5
- DIMMs, 9-13
- disk drive, 6-2
- DVD-ROM backplane, 6-16
- DVD-ROM drive, 6-14
- IB fan, 7-12
- L2 Repeater board, 11-2
- main fan, 7-4
- main fan tray, 7-7
- memory modules, 9-13
- PCI card, 10-9
- power distribution board, 8-6
- power supply, 8-3
- removable media module, 6-6
- SSC reader, 6-18
- system indicator board, 12-2
- tape drive, 6-11

removing side handle, 15-1

retention nut

- installing, 3-13

retention washer

- installing, 3-13

S

- safety precautions, 2-2
- SCC reader
 - installing, 6-21
 - removing, 6-18
- SCSI implementation, B-6
- shipping cradle, 3-5
 - attaching handles, 3-6
- shutdown
 - system controller command, 4-2
- side handle, 15-1
- sliding the system
 - from rack, 3-2, 3-5
- Solaris OS
 - halting, 4-2
- spare parts, A-1
- Standby mode, 4-2
- standby mode, entering, 4-2
- SunVTS
 - description, 1-7
 - documentation, 1-8
- syslog file, 1-5
- system
 - powering on, 4-1
 - Standby mode, 4-2
- system cabinet
 - sliding system out, 3-2, 3-5
- System Controller
 - troubleshooting, 1-7
- System Controller and I/O assembly, *See* *IB_SSC*
- system indicator board
 - installing, 12-4
 - removing, 12-2
- system precautions, 2-4

T

- tape drive
 - installing, 6-12
 - removing, 6-11
- test, 1-5
- tools required, 2-8
- transporting the system
 - between cabinets, 3-5
- transporting the system cabinet

- containing installed systems, 3-13

W

- wrist strap, attaching, 2-7

X

- x-options, A-1