



Sun Fire™ V490 Server Setup and Rackmounting Guide

Sun Microsystems, Inc.
www.sun.com

Part No. 817-3959-10
August 2004, Revision A

Submit comments about this document at: <http://www.sun.com/hwdocs/feedback>

Copyright 2004 Sun Microsystems, Inc., 4150 Network Circle, Santa Clara, California 95054, U.S.A. All rights reserved.

Sun Microsystems, Inc. has intellectual property rights relating to technology embodied in the product that is described in this document. In particular, and without limitation, these intellectual property rights may include one or more of the U.S. patents listed at <http://www.sun.com/patents> and one or more additional patents or pending patent applications in the U.S. and in other countries.

This document and the product to which it pertains are distributed under licenses restricting their use, copying, distribution, and decompilation. No part of the product or of this document may be reproduced in any form by any means without prior written authorization of Sun and its licensors, if any.

Third-party software, including font technology, is copyrighted and licensed from Sun suppliers.

Parts of the product may be derived from Berkeley BSD systems, licensed from the University of California. UNIX is a registered trademark in the U.S. and in other countries, exclusively licensed through X/Open Company, Ltd.

Sun, Sun Microsystems, the Sun logo, Sun Fire, Solaris, SunVTS, OpenBoot and the Solaris logo are trademarks or registered trademarks of Sun Microsystems, Inc. in the U.S. and other countries.

All SPARC trademarks are used under license and are trademarks or registered trademarks of SPARC International, Inc. in the U.S. and other countries. Products bearing SPARC trademarks are based upon an architecture developed by Sun Microsystems, Inc.

The OPEN LOOK and Sun™ Graphical User Interface was developed by Sun Microsystems, Inc. for its users and licensees. Sun acknowledges the pioneering efforts of Xerox in researching and developing the concept of visual or graphical user interfaces for the computer industry. Sun holds a non-exclusive license from Xerox to the Xerox Graphical User Interface, which license also covers Sun's licensees who implement OPEN LOOK GUIs and otherwise comply with Sun's written license agreements.

U.S. Government Rights—Commercial use. Government users are subject to the Sun Microsystems, Inc. standard license agreement and applicable provisions of the FAR and its supplements.

DOCUMENTATION IS PROVIDED "AS IS" AND ALL EXPRESS OR IMPLIED CONDITIONS, REPRESENTATIONS AND WARRANTIES, INCLUDING ANY IMPLIED WARRANTY OF MERCHANTABILITY, FITNESS FOR A PARTICULAR PURPOSE OR NON-INFRINGEMENT, ARE DISCLAIMED, EXCEPT TO THE EXTENT THAT SUCH DISCLAIMERS ARE HELD TO BE LEGALLY INVALID.

Copyright 2004 Sun Microsystems, Inc., 4150 Network Circle, Santa Clara, California 95054, Etats-Unis. Tous droits réservés.

Sun Microsystems, Inc. a les droits de propriété intellectuels relatants à la technologie incorporée dans le produit qui est décrit dans ce document. En particulier, et sans la limitation, ces droits de propriété intellectuels peuvent inclure un ou plus des brevets américains énumérés à <http://www.sun.com/patents> et un ou les brevets plus supplémentaires ou les applications de brevet en attente dans les Etats-Unis et dans les autres pays.

Ce produit ou document est protégé par un copyright et distribué avec des licences qui en restreignent l'utilisation, la copie, la distribution, et la décompilation. Aucune partie de ce produit ou document ne peut être reproduite sous aucune forme, par quelque moyen que ce soit, sans l'autorisation préalable et écrite de Sun et de ses bailleurs de licence, s'il y en a.

Le logiciel détenu par des tiers, et qui comprend la technologie relative aux polices de caractères, est protégé par un copyright et licencié par des fournisseurs de Sun.

Des parties de ce produit pourront être dérivées des systèmes Berkeley BSD licenciés par l'Université de Californie. UNIX est une marque déposée aux Etats-Unis et dans d'autres pays et licenciée exclusivement par X/Open Company, Ltd.

Sun, Sun Microsystems, le logo Sun, Sun Fire, Solaris, SunVTS, OpenBoot et le logo Solaris sont des marques de fabrique ou des marques déposées de Sun Microsystems, Inc. aux Etats-Unis et dans d'autres pays.

Toutes les marques SPARC sont utilisées sous licence et sont des marques de fabrique ou des marques déposées de SPARC International, Inc. aux Etats-Unis et dans d'autres pays. Les produits portant les marques SPARC sont basés sur une architecture développée par Sun Microsystems, Inc.

L'interface d'utilisation graphique OPEN LOOK et Sun™ a été développée par Sun Microsystems, Inc. pour ses utilisateurs et licenciés. Sun reconnaît les efforts de pionniers de Xerox pour la recherche et le développement du concept des interfaces d'utilisation visuelle ou graphique pour l'industrie de l'informatique. Sun détient une licence non exclusive de Xerox sur l'interface d'utilisation graphique Xerox, cette licence couvrant également les licenciées de Sun qui mettent en place l'interface d'utilisation graphique OPEN LOOK et qui en outre se conforment aux licences écrites de Sun.

LA DOCUMENTATION EST FOURNIE "EN L'ÉTAT" ET TOUTES AUTRES CONDITIONS, DECLARATIONS ET GARANTIES EXPRESSES OU TACITES SONT FORMELLEMENT EXCLUES, DANS LA MESURE AUTORISEE PAR LA LOI APPLICABLE, Y COMPRIS NOTAMMENT TOUTE GARANTIE IMPLICITE RELATIVE A LA QUALITE MARCHANDE, A L'APTITUDE A UNE UTILISATION PARTICULIERE OU A L'ABSENCE DE CONTREFAÇON.

Contents

Preface	vii
1. Installing a Sun Fire V490 Server Into a 4-Post Cabinet	1
Checklist of 4-Post Rackmounting and Setup Tasks	2
Unpack the Server	3
Inventory for 4-Post Rackmounting	5
Attach the Inner Glides to the Chassis	7
Prepare the Cabinet	8
Locate the Mounting Holes	9
Install the Slide Assemblies	11
Install the Server Into the Cabinet	17
What Next	19
2. Installing a Sun Fire V490 Server Into a 2-Post Rack	21
Checklist of 2-Post Rackmounting and Setup Tasks	22
Inventory for 2-Post Rackmounting	23
Attach the Mounting Brackets to the Chassis	24
Locate the Mounting Holes	25
Install the Mounting Screws	26
Install the Server Into the Rack	27

Install the Server Into a Populated Rack 29

What Next 30

3. Setup Procedures 31

Inventory for Setup Procedures 32

Install the Cable Management Arm 33

Connect the Cords and Cables 40

Connect the Power Cords 41

Connect a Twisted-Pair Ethernet Cable 44

Secure the Cables to the Cable Management Arm 46

Restore the Cabinet 50

What Next 50

A. 4-Post Cabinet Requirements 51

Tables

TABLE 1-1	Overview of 4-Post Rackmounting and Setup Tasks	2
TABLE 2-1	Overview of 2-Post Rackmounting and Setup Tasks	22
TABLE 3-1	Back Panel Ports	40
TABLE A-1	4-Post Rack Requirements	52

Preface

This guide provides instructions for installing the Sun Fire™ V490 server into a 4-post Sun™ expansion cabinet or other EIA-compliant 19-inch (48.26-cm) wide cabinet and into a 2-post rack. This guide also provides instructions for installing a cable management arm, connecting power cords, and connecting an Ethernet cable.

When you have completed the procedures in this guide, you are ready to set up a system console, power on the server, install the Solaris™ Operating System, and install the electronic documentation. See the *Sun Fire V490 Server Quick Start Guide* or Part One of the *Sun Fire V490 Server Administration Guide* for information about these procedures.

How This Book Is Organized

This book is organized into the following chapters.

Chapter 1 provides instructions for installing the server into a 4-post cabinet.

Chapter 2 provides instructions for installing the server into a 2-post rack.

Chapter 3 provides instructions for installing a cable management arm, connecting power cords, and connecting an Ethernet cable.

Typographic Conventions

Typeface	Meaning	Examples
AaBbCc123	The names of commands, files, and directories; on-screen computer output	Edit your .login file. Use <code>ls -a</code> to list all files. % You have mail.
AaBbCc123	What you type, when contrasted with on-screen computer output	% su Password:
<i>AaBbCc123</i>	Book titles, new words or terms, words to be emphasized Command-line variable; replace with a real name or value	Read Chapter 2 in the <i>Sun Fire V490 Setup and Rackmounting Guide</i> . To delete a file, type <code>rm filename</code> .

Related Documentation

Application	Title	Part Number
Late-breaking information	<i>Sun Fire V490 Server Product Notes</i>	817-4193
Initial installation	<i>Sun Fire V490 Server Quick Start Guide</i>	817-3955
Rackmounting	<i>Sun Fire V490 Server Setup and Rackmounting Guide</i>	817-3959
Site Planning	<i>Site Planning Guide for Entry-Level Servers Version 1.5</i>	816-1613
Service	<i>Sun Fire V490 Server Parts Installation and Removal Guide</i>	817-3952
Administration, configuration, diagnostics, and troubleshooting	<i>Sun Fire V490 Server Administration Guide</i>	817-3951

Accessing Sun Documentation

You can view, print, or purchase a broad selection of Sun documentation, including localized versions, at:

<http://www.sun.com/documentation>

Third-Party Web Sites

Sun is not responsible for the availability of third-party web sites mentioned in this document. Sun does not endorse and is not responsible or liable for any content, advertising, products, or other materials that are available on or through such sites or resources. Sun will not be responsible or liable for any actual or alleged damage or loss caused by or in connection with the use of or reliance on any such content, goods, or services that are available on or through such sites or resources.

Contacting Sun Technical Support

If you have technical questions about this product that are not answered in this document, go to:

<http://www.sun.com/service/contacting>

Sun Welcomes Your Comments

Sun is interested in improving its documentation and welcomes your comments and suggestions. You can submit your comments by going to:

<http://www.sun.com/hwdocs/feedback>

Please include the title and part number of your document with your feedback:

Sun Fire V490 Server Setup and Rackmounting Guide, part number 817-3959-10

Installing a Sun Fire V490 Server Into a 4-Post Cabinet

This chapter describes how to install a Sun Fire™ V490 server into a 4-post Sun expansion cabinet or other EIA-compliant 19-inch (48.26-cm) wide cabinet. If you are installing a Sun Fire V490 server into a 2-post rack, see Chapter 2.

Note – To install a server into a cabinet with mounting holes sized for U.S. screws, use the 10-32 screws included in the rackmounting kit to attach the slide assemblies to the cabinet. If the mounting holes are sized for metric screws, use the M6 screws included in the rackmounting kit to attach the slide assemblies to the cabinet. Use the same screws to secure the server to the front mounting rails.

The service label affixed to the top of the server chassis illustrates the rackmounting steps in a convenient graphical overview.

This chapter contains the following procedures and information:

- [“Checklist of 4-Post Rackmounting and Setup Tasks” on page 2](#)
- [“Unpack the Server” on page 3](#)
- [“Inventory for 4-Post Rackmounting” on page 5](#)
- [“Attach the Inner Glides to the Chassis” on page 7](#)
- [“Prepare the Cabinet” on page 8](#)
- [“Locate the Mounting Holes” on page 9](#)
- [“Install the Slide Assemblies” on page 11](#)
- [“Install the Server Into the Cabinet” on page 17](#)

Checklist of 4-Post Rackmounting and Setup Tasks

TABLE 1-1 Overview of 4-Post Rackmounting and Setup Tasks

Step	Task	Refer to:
1	Unpack the server, the ship kit, and the rack kit.	“Unpack the Server” on page 3
2	Check that you have the required parts for rackmounting.	“Inventory for 4-Post Rackmounting” on page 5
3	Install the inner glides onto the chassis.	“Attach the Inner Glides to the Chassis” on page 7
4	Prepare the cabinet.	“Prepare the Cabinet” on page 8
5	Locate the mounting holes.	“Locate the Mounting Holes” on page 9
6	Install the slide assemblies onto the cabinet.	“Install the Slide Assemblies” on page 11
7	Install the server into the cabinet.	“Install the Server Into the Cabinet” on page 17
8	Check that you have the cable management arm and the cords and cables for setup.	“Inventory for Setup Procedures” on page 32
9	Install the cable management arm.	“Install the Cable Management Arm” on page 33
10	Connect the power cords.	“Connect the Power Cords” on page 41
11	Connect a twisted-pair Ethernet (TPE) cable.	“Connect a Twisted-Pair Ethernet Cable” on page 44
12	Secure the cables to the cable management arm.	“Secure the Cables to the Cable Management Arm” on page 46
13	Restore the cabinet.	“Restore the Cabinet” on page 50

Unpack the Server

Inspect all shipping cartons for evidence of physical damage. If a shipping carton is damaged, request that the carrier's agent be present when the carton is opened. Keep all contents and packing material for the agent's inspections.

Unpack the server, the ship kit, and the rack kit. The documentation tray and the ship kit box contain user documentation.

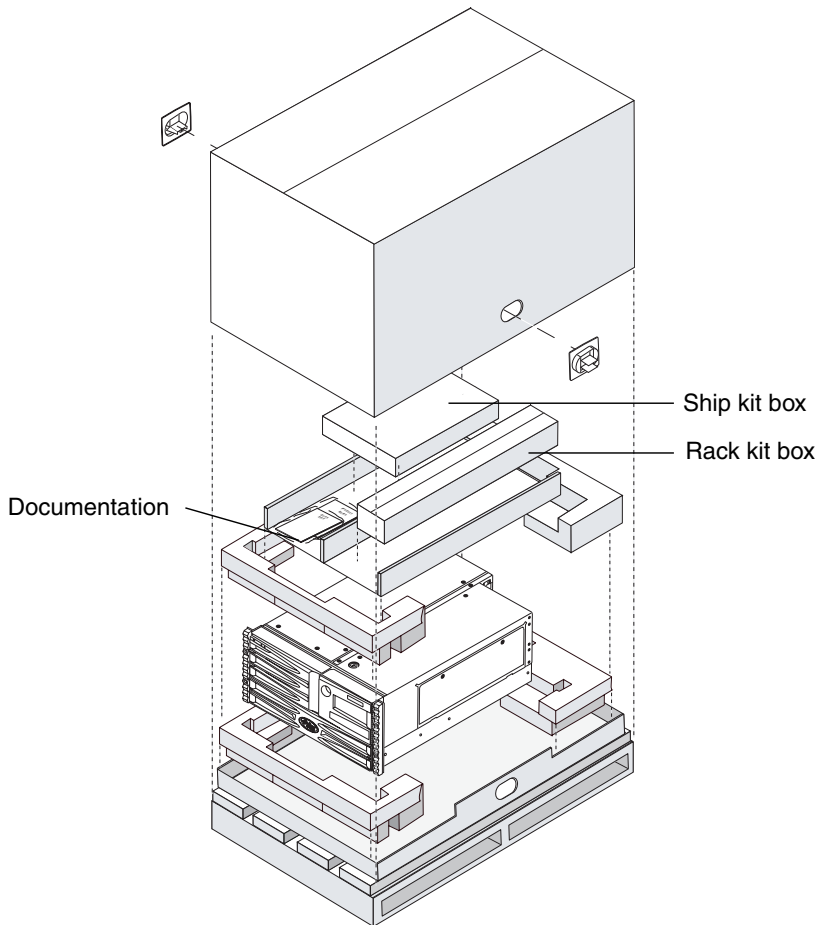

Check that you have received all of the parts you ordered. Peripherals that are not factory installed are shipped separately. Contact Sun Microsystems or your distributor or reseller if you are missing anything.

Note – With the exception of internal disk drives and power supplies, all component part installation or replacement must be performed by a qualified service provider. If your server options are not fully installed, see the *Sun Fire V490 Server Parts Installation and Removal Guide* for installation instructions or contact a qualified service provider.

Note – 2-post rackmounting kits are shipped separately.

Inventory for 4-Post Rackmounting

You need one 4-post rackmounting kit for each Sun Fire V490 server you intend to install into a cabinet. You also need this document and the Rack Alignment template from the ship kit.

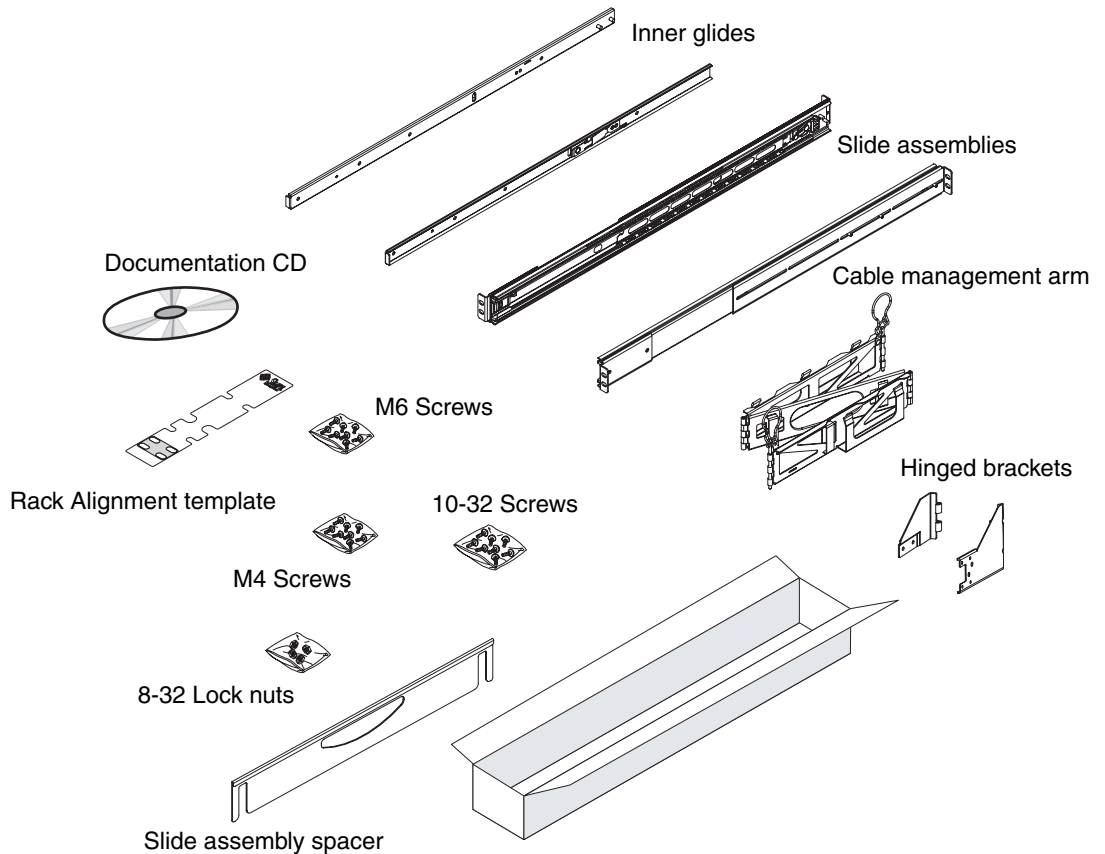

The plastic bags of hardware contain screws shown below in actual size.

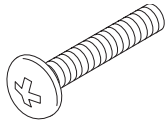

10-32 Screws (12)



M4 Screws (8)

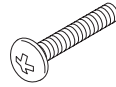

M6 Screws (12)



8-32 Lock nuts (4)

Any screws not used for rackmounting are spares.

Note – Bar nuts are required (but not included) for non-threaded cabinets. See the instructions provided with your cabinet for more information.

Tools Required

You will need the following tools when rackmounting the server:

- Phillips No. 2 screwdriver (Use to tighten 10-32 screws.)
- Phillips No. 3 screwdriver (Use to tighten M6 screws.)
- Set of appropriate Allen wrenches to remove the side panels on some cabinets
- Adjustable wrench to tighten the nuts on the mounting brackets
- 11/32 socket wrench or nut driver (Use to install hinged brackets.)

Attach the Inner Glides to the Chassis

- **Attach the inner glides to the chassis using four M4 screws for each inner glide.**
Position the straight end of the inner glide toward the front of the system. Align the first hole on the inner glide with the first hole on the chassis.

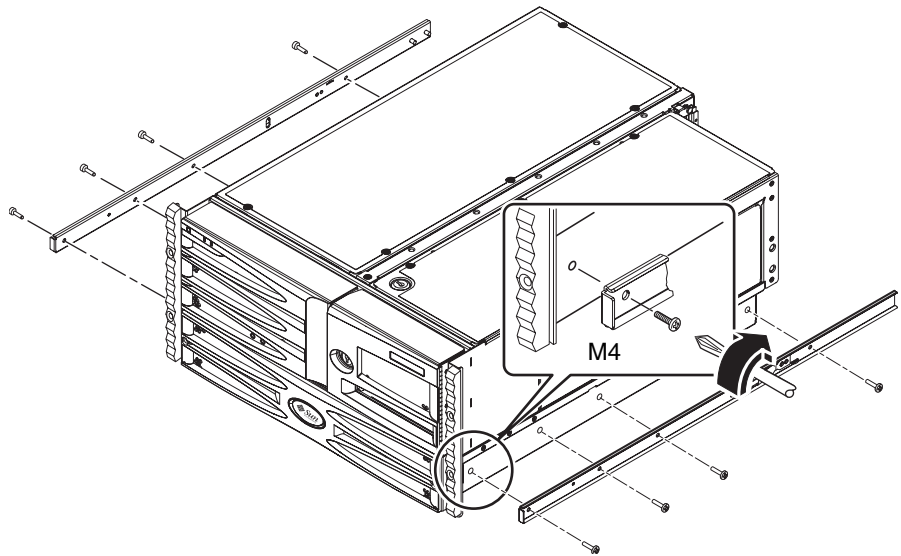

Prepare the Cabinet

1. **Open, and remove if applicable, the front and back doors of the cabinet.**

See the instructions provided with your cabinet.

2. **Stabilize the cabinet by extending its anti-tip legs or bolting the cabinet securely to the floor.**

See the instructions provided with your cabinet and read [“4-Post Cabinet Requirements” on page 51.](#)

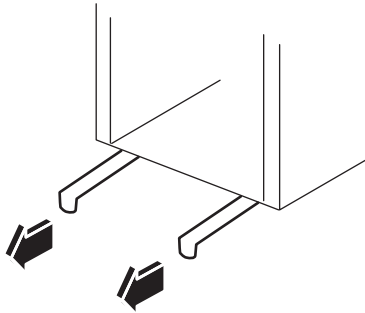

3. **Remove the side panels from the cabinet, if applicable.**

See the instructions provided with your cabinet. Removing the side panels can improve access to the nuts and screws that you install when securing the server in the cabinet.

Locate the Mounting Holes

- **Locate and mark the rack rail holes that you will use to attach each slide assembly.**

You can either count the holes on the vertical rack rails or use the Rack Alignment template included with your documentation set. Make sure that each slide assembly is installed at the same height front-to-back and side-to-side in the rack.

The Rack Alignment template is five rack units (8.75 in/22.22 cm) tall. Because the holes on a standard rack rail are arranged in sets of three holes spaced $\frac{5}{8}$ ths, $\frac{5}{8}$ ths, and $\frac{1}{2}$ of an inch apart, which *two holes* you use for attaching a slide assembly varies depending on exactly where in the rack the server is located.

One side of the Rack Alignment template is for 2-post rackmounting, the other side is for 4-post rackmounting. For 2-post rackmounting instructions, see Chapter 2.

The 4-post mounting holes on the Rack Alignment template are for mounting the slide bracket to the vertical rack rail. The upper and lower retainer screw openings in the template locate the server retainer screws that hold the server in the rack after it is installed.

The following figure shows both sides of the Rack Alignment template.

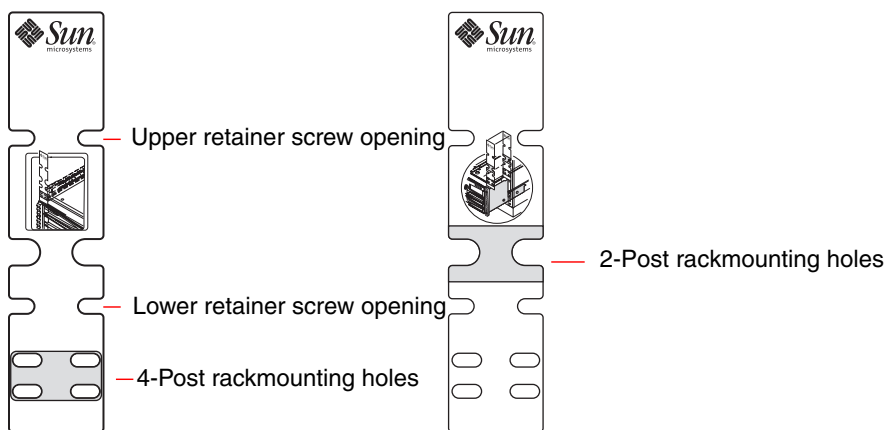

To use the Rack Alignment template, complete these steps:

- a. Place the Rack Alignment template over the left front vertical rack rail, then move the bottom of the template to the location on the rack rail where the bottom of the server will be located.

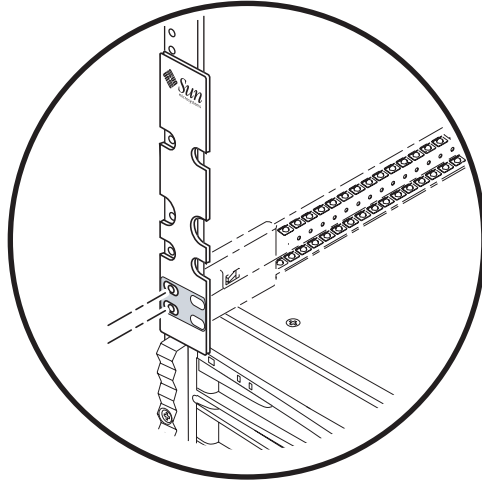

- b. Adjust the Rack Alignment template until the lower retainer screw opening is centered on a hole in the rail.
- c. Looking through the two slide bracket mounting holes on the Rack Alignment template, locate and mark the *two* holes on the vertical rack rail that are most visible through the template.
Use these two mounting holes to attach the slide assembly to the front rail. Mark the corresponding holes on the right front vertical rack rail.

Guidelines for Installing Slide Assemblies



Caution – Stabilize the cabinet by extending its anti-tip legs or bolting the cabinet securely to the floor.

- If this is the first server you are installing into the cabinet, use holes 9 and 10 or 11 (this assumes that an AC power sequencer occupies holes 1 through 6 in the bottom of the cabinet).
- Install the slide assemblies into the lowest available position.
- Install additional servers from the base up in the cabinet.

Install the Slide Assemblies

1. Use the Rack Alignment template to locate and mark mounting holes on the vertical rack rails.
See [“Locate the Mounting Holes”](#) on page 9.
2. Adjust the back mounting brackets to accommodate the depth of the rack.
 - a. Loosen the three 8-32 lock nuts that secure the back mounting bracket to the slide assembly.
 - b. Position a slide assembly in the cabinet where you marked the mounting holes.

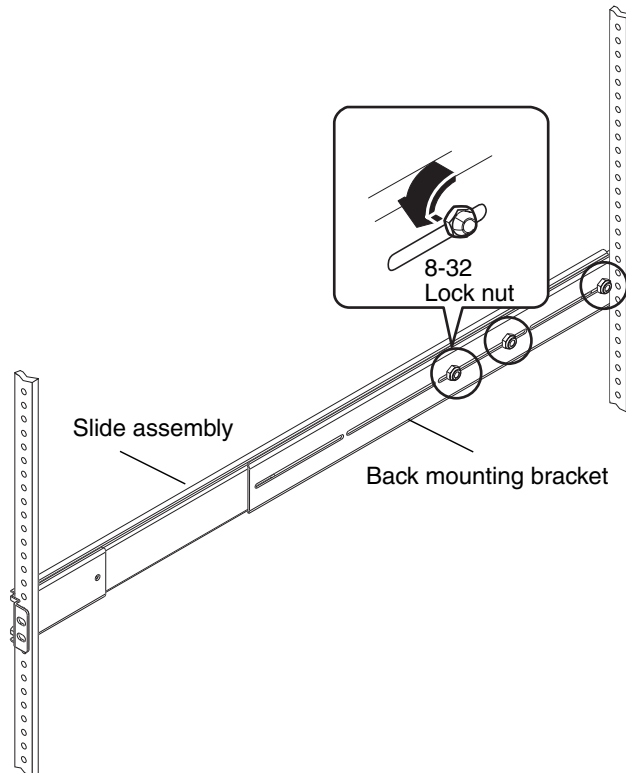

- c. Move the bracket forward or backward on the slide assembly until you have the correct position to accommodate the depth of the rack.

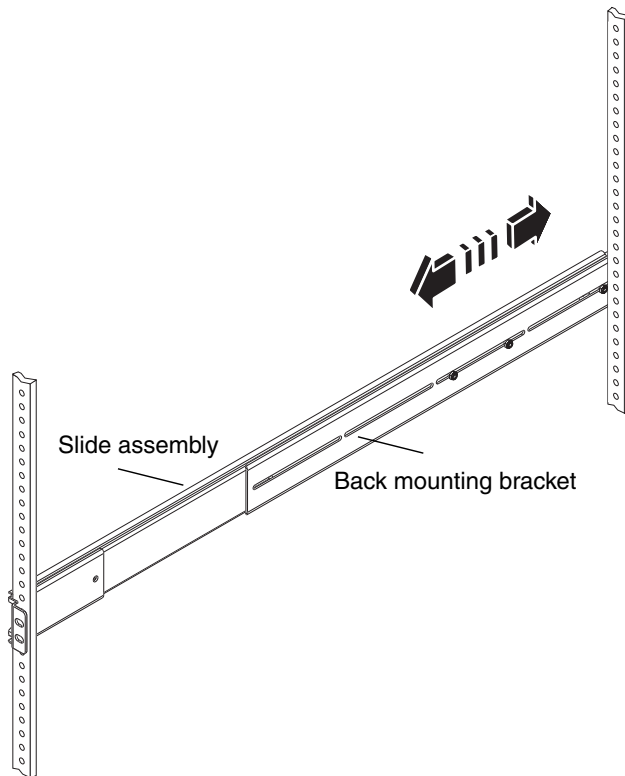

Note – If necessary, fully remove the three lock nuts and the back mounting bracket from the slide assembly to adjust the back mounting bracket to the depth of the rack. Hold the back mounting bracket on the slide assembly and move it forward or backward until you have the correct position to accommodate the depth of the rack. Secure the back mounting bracket to the slide assembly with the three lock nuts.

- d. Loosely tighten the three lock nuts that secure the back mounting bracket to the slide assembly. Do not fully tighten the lock nuts.
- e. Repeat these steps to adjust the other back mounting bracket.

3. **With the help of an assistant, position the slide assembly on the right mounting rail as viewed from the front.**

The front (short) mounting bracket should be at the front of the rack.

- a. **Use the holes you marked in Step 1.**
 - b. **Use the same slide assembly you adjusted in Step 2.**
 - c. **Make sure that the slide assembly is level front-to-back.**
4. **Using the appropriate screws for the rack, attach the front mounting bracket to the front rail of the rack and attach the back (long) mounting bracket of the same slide assembly to the back rail of the rack.**
 - a. **Count the rack rail holes to ensure that you are matching the holes used on the front rail.**
 - b. **Use the appropriate screws for your type of rack:**
 - Racks with mounting holes sized for U.S. dimensions require 10-32 screws.
 - Racks with mounting holes sized for metric dimensions require M6 screws.
Partially tighten the front bracket screws and the back bracket screws.

Note – Do not fully tighten the screws that attach the brackets to the vertical mounting rails until after you use the slide assembly spacer to make sure that the rails are evenly spaced and aligned.

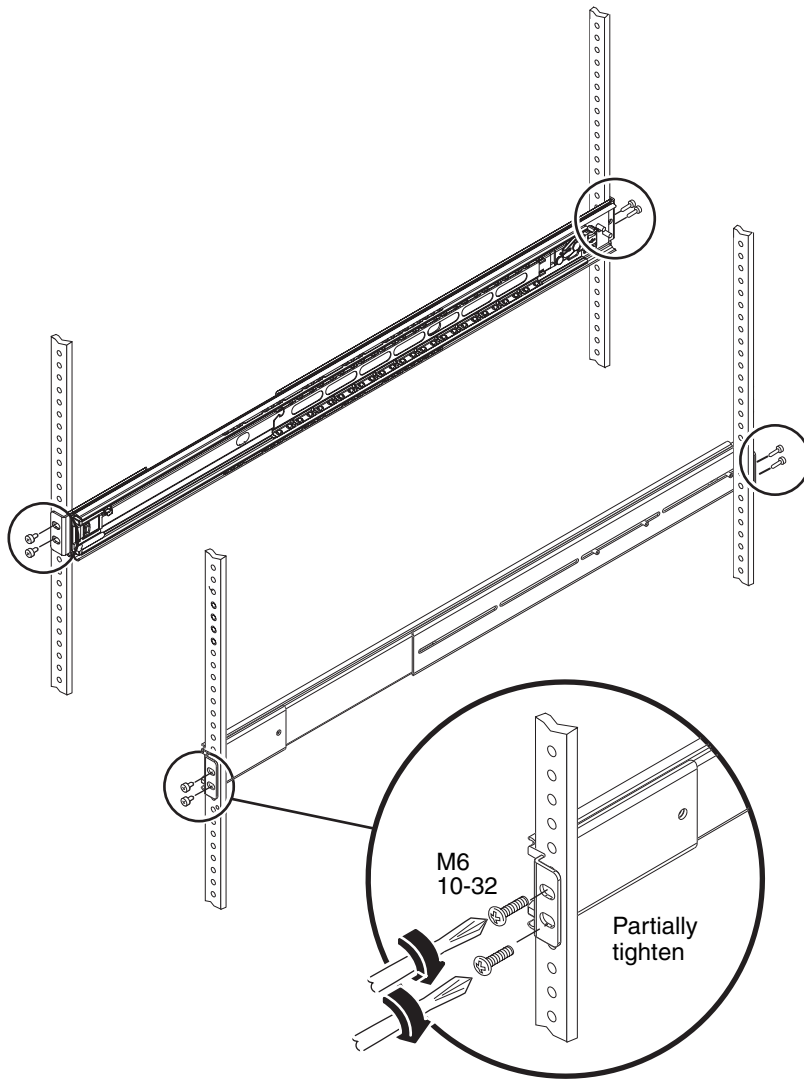

5. Repeat Steps 3 and 4 for the other slide assembly.

6. Use the slide assembly spacer to make sure that the slide assemblies are evenly spaced and aligned correctly.

The slide assembly spacer is included in the rack kit.

- a. Place the slide assembly spacer over the left and right slide assemblies at the front of the rack.

The slots on the slide assembly spacer should fit evenly over the rails.

- b. With the slide assembly spacer in place, fully tighten the front bracket screws.

- c. Place the slide assembly spacer over the left and right slide assemblies at the back of the rack.

- d. With the slide assembly spacer in place, fully tighten the back bracket screws.

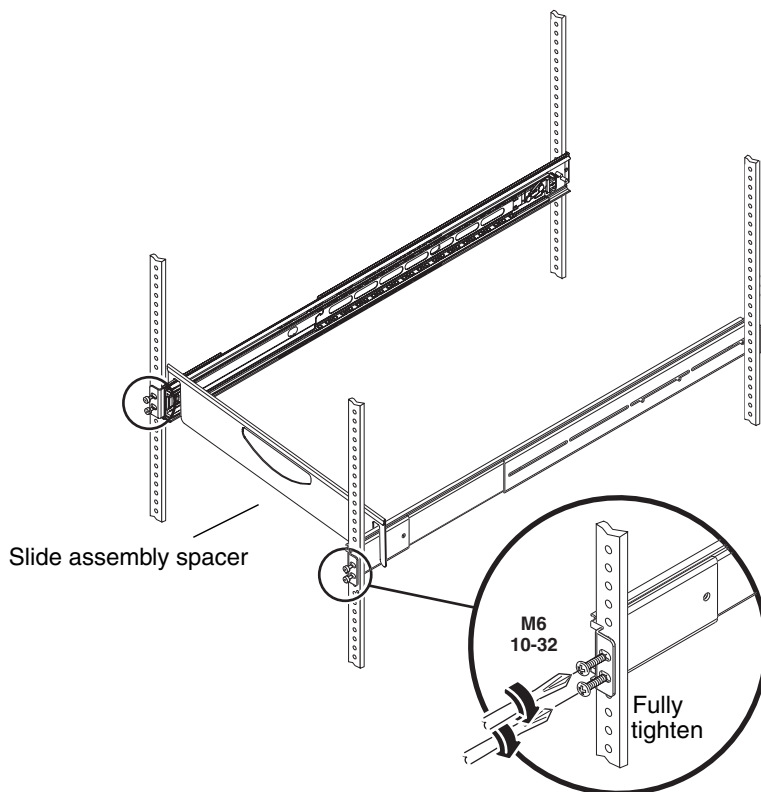

7. Make sure that each slide assembly is fully retracted into the cabinet as shown in the next figure.
8. Fully tighten the three 8-32 lock nuts on the back mounting bracket.

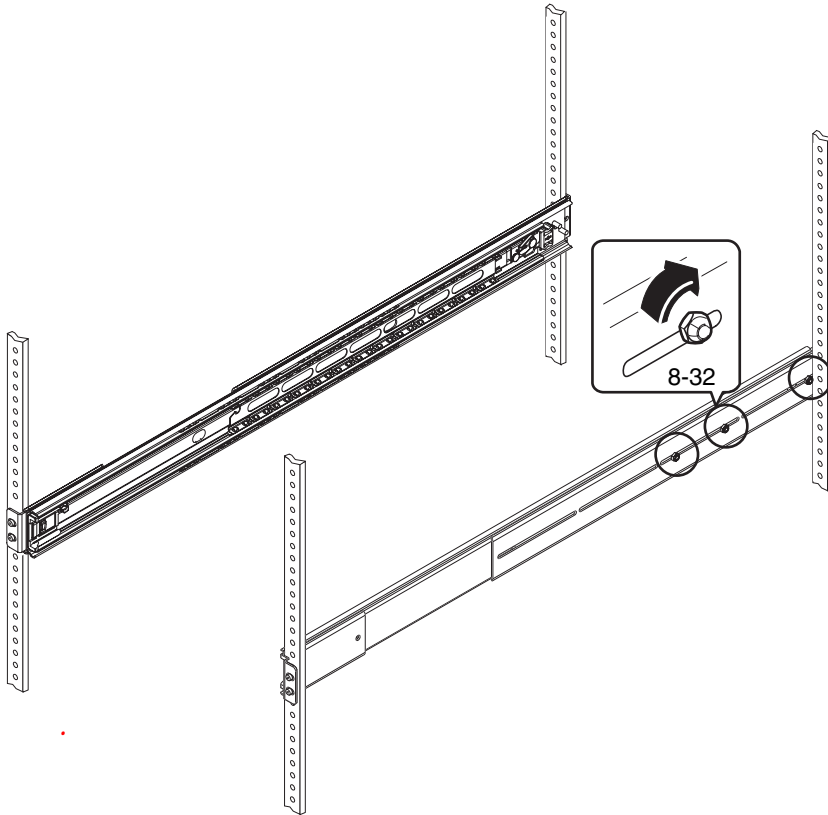

Install the Server Into the Cabinet



Caution – Before you install or remove the server from the cabinet, ensure that the cabinet is stabilized so that it cannot move or tip forward. See the cabinet documentation for information about stabilizing the cabinet.



Caution – The server is heavy. Two persons are required to install or remove the server into the rack.

Note – Make sure that each slide assembly is fully retracted into the cabinet and check that the ball-bearing runner on each slide assembly is all the way forward.

1. **Lift the server (one person on each side of the server) and approach the cabinet with the back of the server facing the front of the cabinet.**
2. **Align the rounded ends of the inner glides on the server with the slide assemblies in the cabinet.**

Note – Make sure that the inner glides attached to the server are inserted within the ball-bearing runners, and the server is level when inserting it into the ball bearing runners.

3. Holding the server level, slide it evenly all the way into the cabinet.

Note – Make sure that the server is level when inserting it into the ball bearing runners.

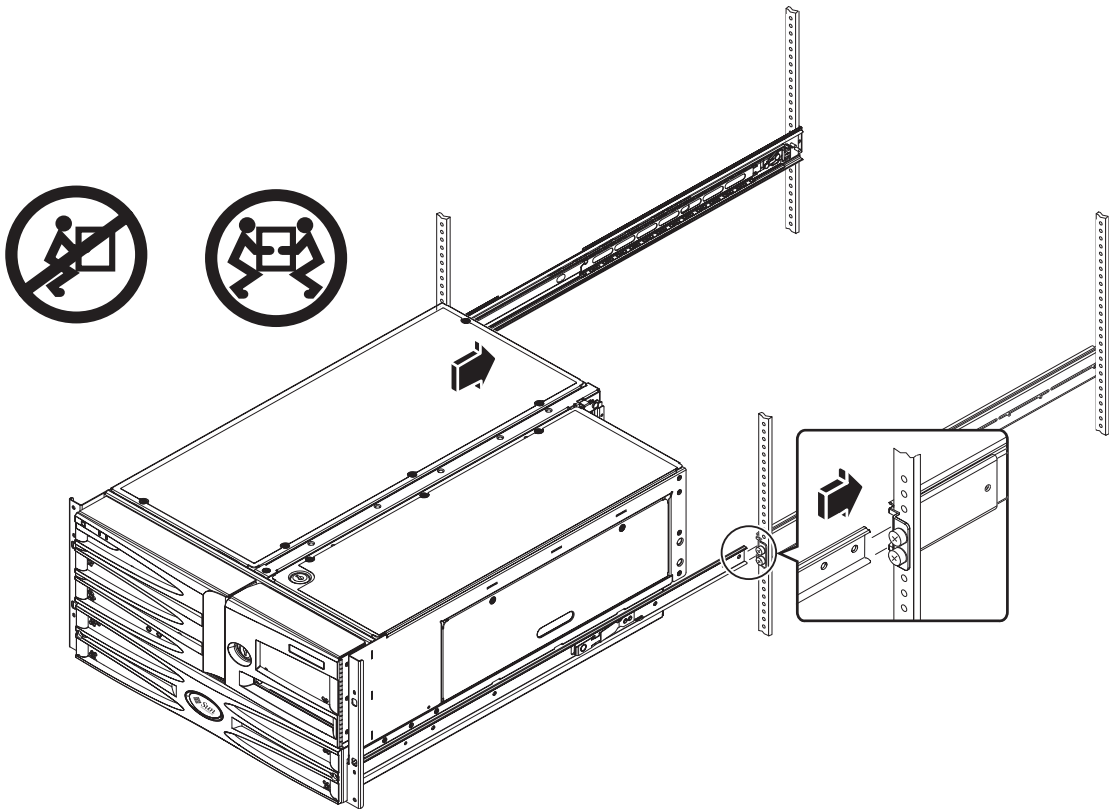

Tip – Slide the server in and out of the cabinet slowly and carefully to ensure that the slide assemblies are working correctly and are free from obstructions.

Note – If you fully extend the server out of the cabinet, press the catch on each inner glide to slide the server all the way back into the cabinet.

4. Secure the server to the front vertical mounting rails using either four M6 screws or four 10-32 screws included in the rack kit.

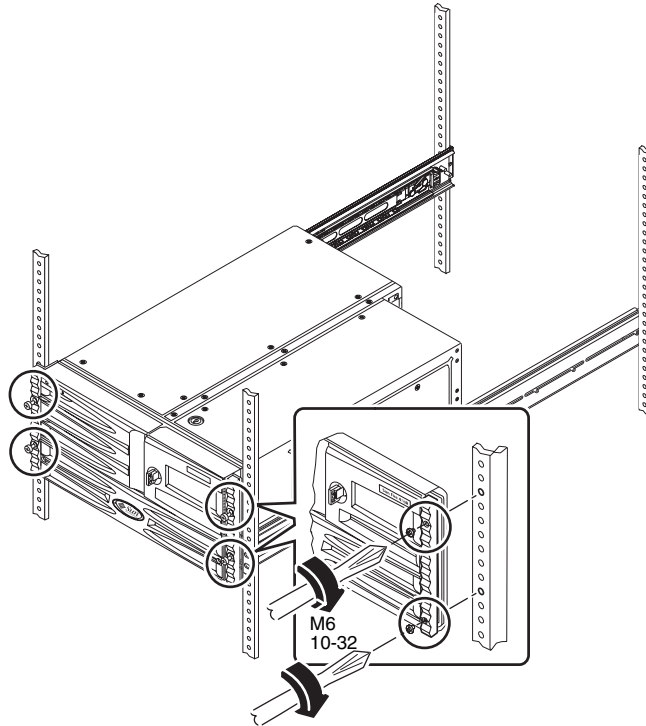

What Next

The next step is to connect the power cords and an Ethernet cable. See Chapter 3.

Installing a Sun Fire V490 Server Into a 2-Post Rack

This chapter provides step-by-step instructions for installing a Sun Fire V490 server into a 2-post rack.

Note – When a Sun Fire V490 server is installed into a 2-post rack, only the disk drives and power supplies are serviceable in the rack. You need to remove the server from the rack to service any other component. See the *Sun Fire V490 Server Parts Installation and Removal Guide* for more information.

This chapter contains the following procedures and information:

- [“Checklist of 2-Post Rackmounting and Setup Tasks” on page 22](#)
- [“Inventory for 2-Post Rackmounting” on page 23](#)
- [“Attach the Mounting Brackets to the Chassis” on page 24](#)
- [“Locate the Mounting Holes” on page 25](#)
- [“Install the Mounting Screws” on page 26](#)
- [“Install the Server Into the Rack” on page 27](#)
- [“Install the Server Into a Populated Rack” on page 29](#)

Checklist of 2-Post Rackmounting and Setup Tasks

TABLE 2-1 Overview of 2-Post Rackmounting and Setup Tasks

Step	Task	Refer to:
1	Unpack the rackmounting kit and verify the contents.	“Inventory for 2-Post Rackmounting” on page 23
2	Attach the brackets to the server.	“Attach the Mounting Brackets to the Chassis” on page 24
3	Locate the mounting holes.	“Locate the Mounting Holes” on page 25
4	Install the mounting screws.	“Install the Mounting Screws” on page 26
5	Install the server into the rack.	“Install the Server Into the Rack” on page 27
6	Install the cable management arm.	“Install the Cable Management Arm” on page 33
7	Connect the power cords.	“Connect the Power Cords” on page 41
8	Connect a twisted-pair Ethernet (TPE) cable	“Connect a Twisted-Pair Ethernet Cable” on page 44

Note – The steps are different if you are installing the server into a populated rack. See [“Install the Server Into a Populated Rack” on page 29](#) for instructions.

Inventory for 2-Post Rackmounting

You need one 2-post rackmounting kit for each Sun Fire V490 server you intend to install into a rack. You also need this document and the Rack Alignment template from the ship kit.

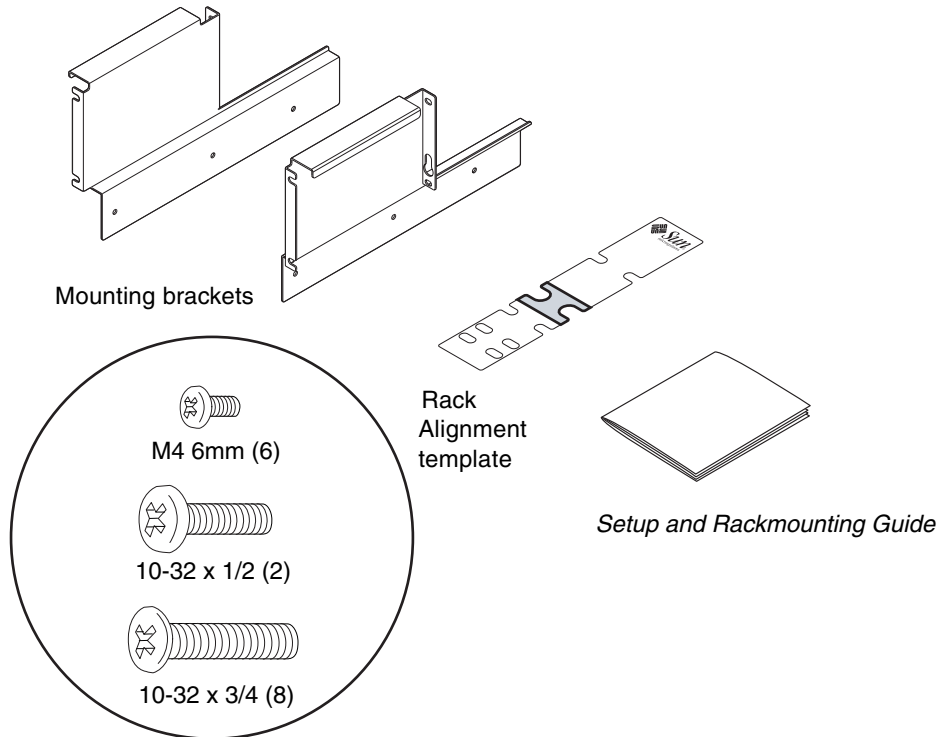

Tool Required

You will need the following tool when rackmounting the server:

- Phillips No. 2 long screwdriver

Attach the Mounting Brackets to the Chassis

- Attach the mounting brackets to the chassis using three M4 screws for each bracket.

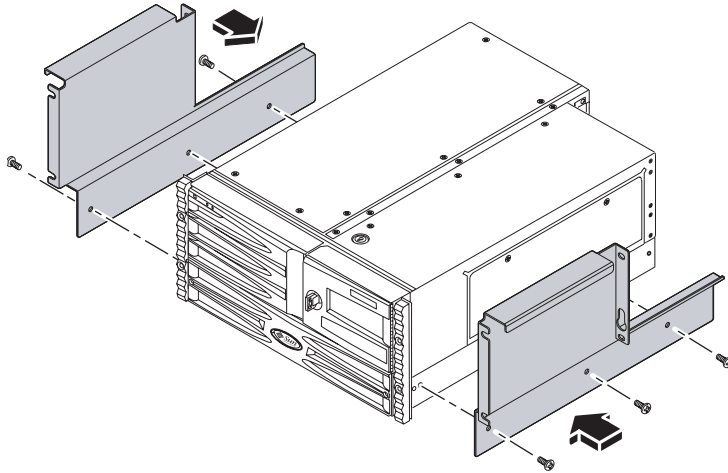

Locate the Mounting Holes

- Use the Rack Alignment template to locate and mark the holes for the mounting screws on each vertical rack rail. Allow five rack unit spaces (8.75 in/22.22 cm) per server.

To use the Rack Alignment template, complete these steps:

- a. Place the Rack Alignment template over the vertical rack rail, with the side marked for 2-post rack installation facing out.
- b. Rest the Rack Alignment template in the space where the server will be installed, lining up the bottom of the Rack Alignment template with the top of the server below. See next figure.
- c. Adjust the Rack Alignment template so that the mounting hole is centered on a rack rail hole and mark that rail hole.

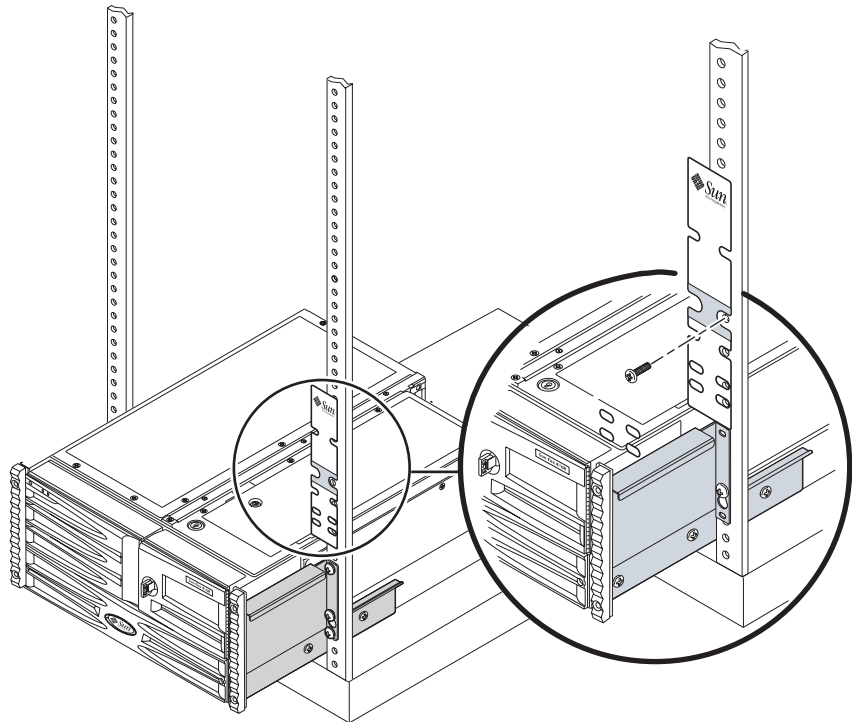

- d. If you are installing the server into a space with fewer than seven rack units, you do not need to locate mounting holes or install mounting screws. You are ready to install the server into the rack. See [“Install the Server Into a Populated Rack”](#) on page 29.

Install the Mounting Screws

- Install one 10-32 x 1/2 screw on the left and one 10-32 x 1/2 screw on the right vertical mounting rails.

Use the holes you marked in the previous procedure. Do not fully tighten the screws until after you install the server. Leave a 0.25-inch (0.64-cm) gap between the head of each screw and the mounting rail.

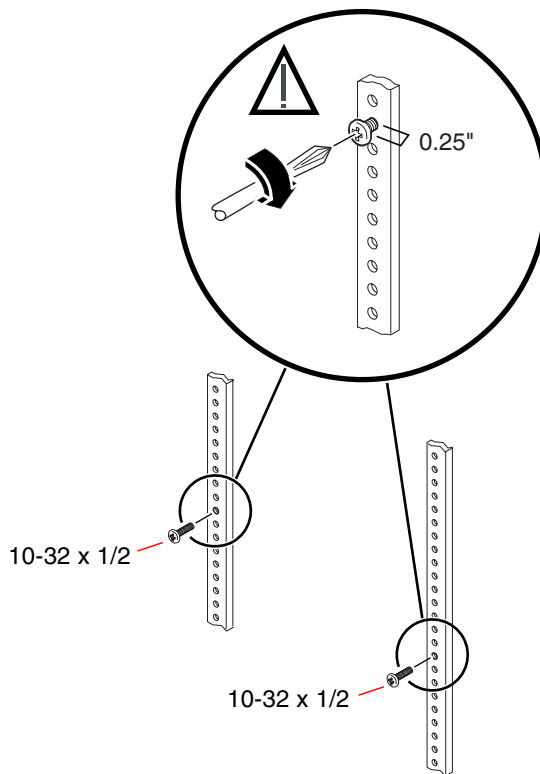

Install the Server Into the Rack



Caution – Before you install or remove the server from the rack, ensure that the rack is stabilized so that it cannot move or tip forward. See the rack documentation for information about stabilizing the rack.



Caution – The server is heavy. Two persons are required to move the server.

1. **Lift the server (one person on each side of the server) and approach the rack with the back of the server facing the front of the rack.**
2. **Lift the server up and over the mounting screw on each vertical mounting rail so that the large hole clears the head of the screw.**
Slide the server down so that the server rests on the mounting screws.
3. **Use six 10-32 screws, two screws and the mounting screw on each side, to secure the server to the vertical mounting rails.**

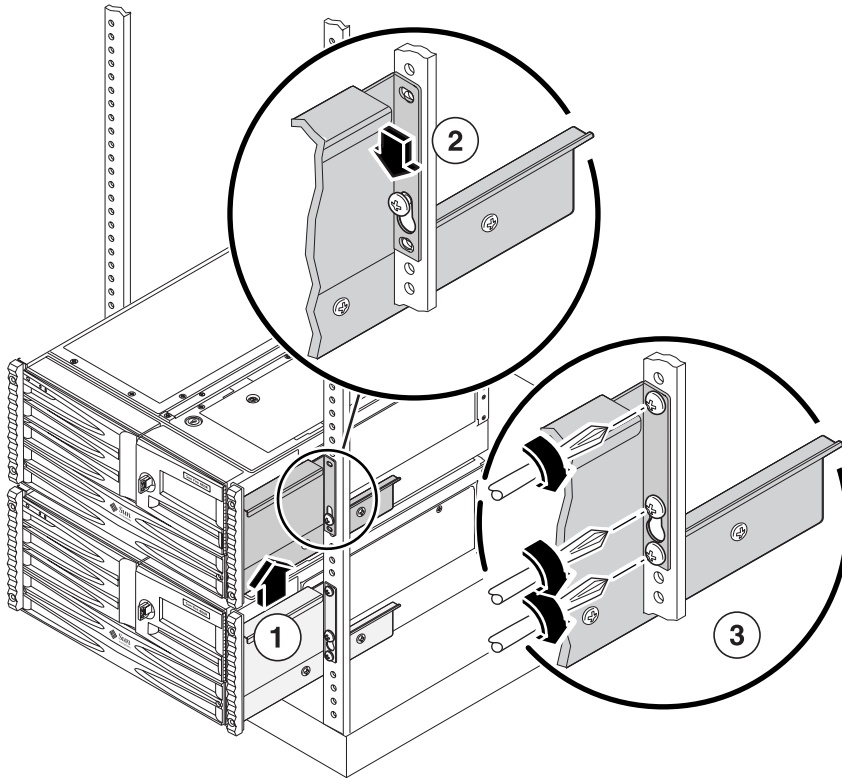

Install the Server Into a Populated Rack

1. Attach the mounting brackets to the chassis using three M4 screws for each bracket. See [“Attach the Mounting Brackets to the Chassis”](#) on page 24 for instructions.
2. Slide the server into the open position in the rack.
Allow six rack unit spaces (10.5 in/26.67 cm) per server.
3. Using a Phillips No. 2 screwdriver, secure the top and bottom screws to the left and the right vertical mounting rails.

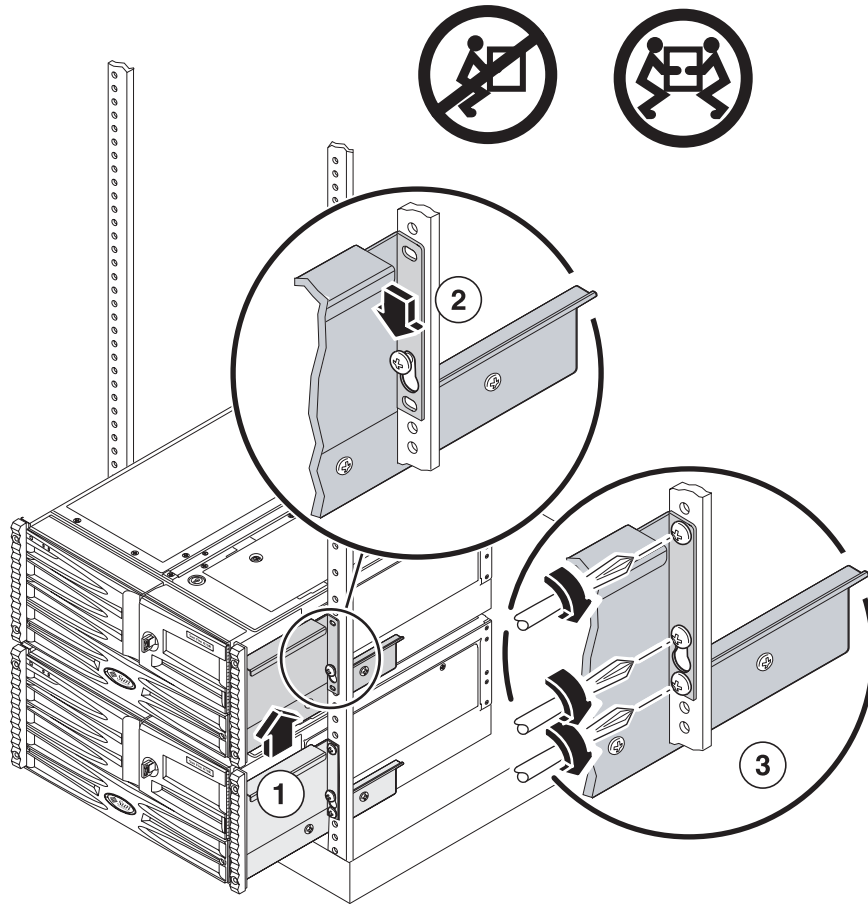



Caution – When installing or removing the server from a populated 2-post rack, be sure to support the weight of the server, so you do not damage the component installed below it in the rack.

What Next

The next step is to connect the power cords and an Ethernet cable. See Chapter 3.

Setup Procedures

This chapter tells you how to install the cable management arm, connect the power cords and an Ethernet cable, and secure the cords and cables to the cable management arm.

When you have completed the procedures in this chapter, you are ready to set up a system console, power on the server, install the Solaris Operating System, and install the electronic documentation. See the *Sun Fire V490 Server Quick Start Guide* or the *Sun Fire V490 Server Administration Guide* for information about these procedures.

Make sure that you have installed the Sun Fire V490 server into a 4-post cabinet or 2-post rack (see Chapters 1 and 2) before following the instructions in this chapter.

This chapter contains the following procedures and information:

- [“Inventory for Setup Procedures”](#) on page 32
- [“Install the Cable Management Arm”](#) on page 33
- [“Connect the Power Cords”](#) on page 41
- [“Connect a Twisted-Pair Ethernet Cable”](#) on page 44
- [“Secure the Cables to the Cable Management Arm”](#) on page 46
- [“Restore the Cabinet”](#) on page 50

Inventory for Setup Procedures

You need the following components from the ship kit and the rack kit to install the cable management arm and connect the cords and cables:

- Cable management arm from the rack kit
- Two hinged brackets from the rack kit
- Four lock nuts from the rack kit
- Power cords
- Ethernet (RJ-45) cable

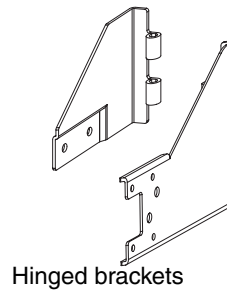
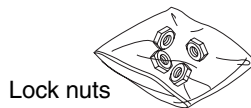
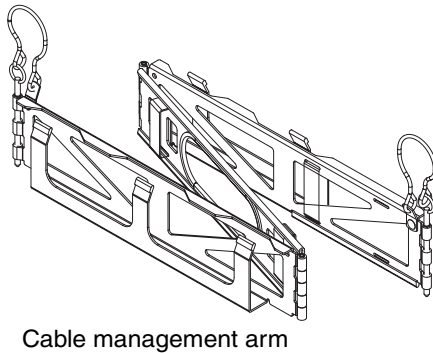
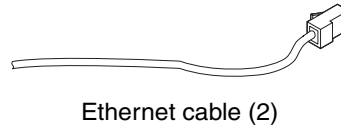
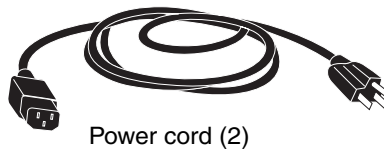

Install the Cable Management Arm

This procedure describes how to attach the cable management arm to a Sun Fire V490 server that is already installed into a cabinet. For instructions on installing the server into a cabinet, see Chapter 1.

- 1. Remove the four screws that secure the system to the left and right vertical rails at the front of the cabinet.**
- 2. Slide the chassis smoothly out of the cabinet about 3 inches (76.2 mm).**

Sliding the server out of the cabinet provides easy access to the areas where you will attach the cable management arm.
- 3. Attach a hinged bracket to the posts on the inner glide, as shown in the next figure.**
 - a. Locate the two horizontal posts on the inner glide on the right side of the chassis as viewed from the rear.**
 - b. Remove the protective covers from the posts.**

- c. Position the holes on the hinged bracket over the two posts on the inner glide.
- d. Secure the hinged bracket to the inner glide using two 8-32 lock nuts.

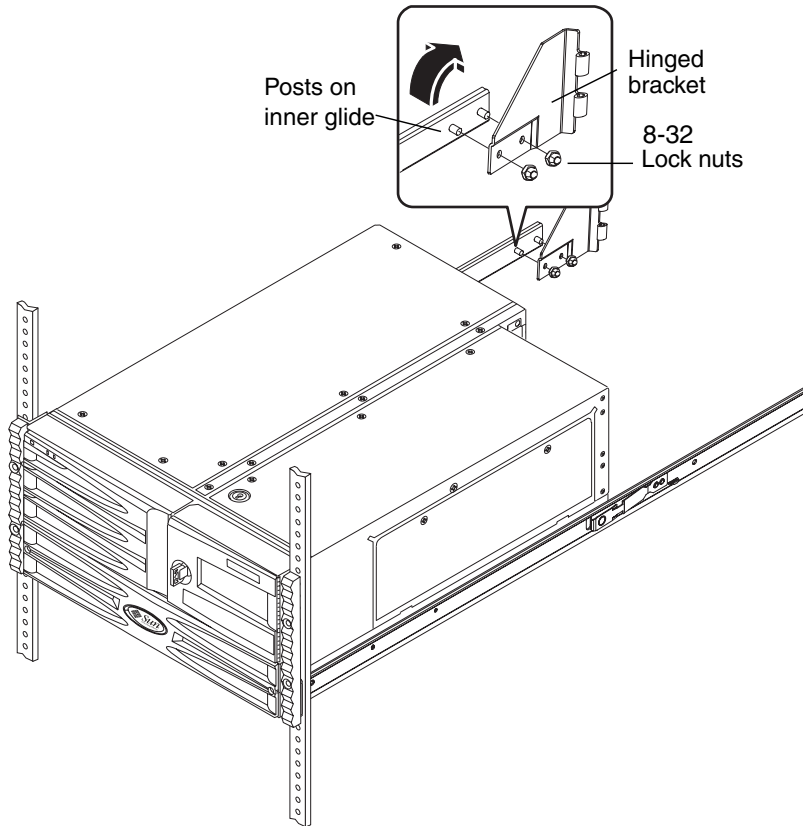

4. Attach the other hinged bracket to the diagonal posts on the opposite slide assembly.
 - a. Locate the two diagonal posts on the left slide assembly as viewed from the rear.
 - b. Remove the protective covers from the posts.
 - c. Position the diagonal holes on the hinged bracket over the two posts on the slide assembly.
 - d. Secure the hinged bracket to the slide assembly using two 8-32 lock nuts.

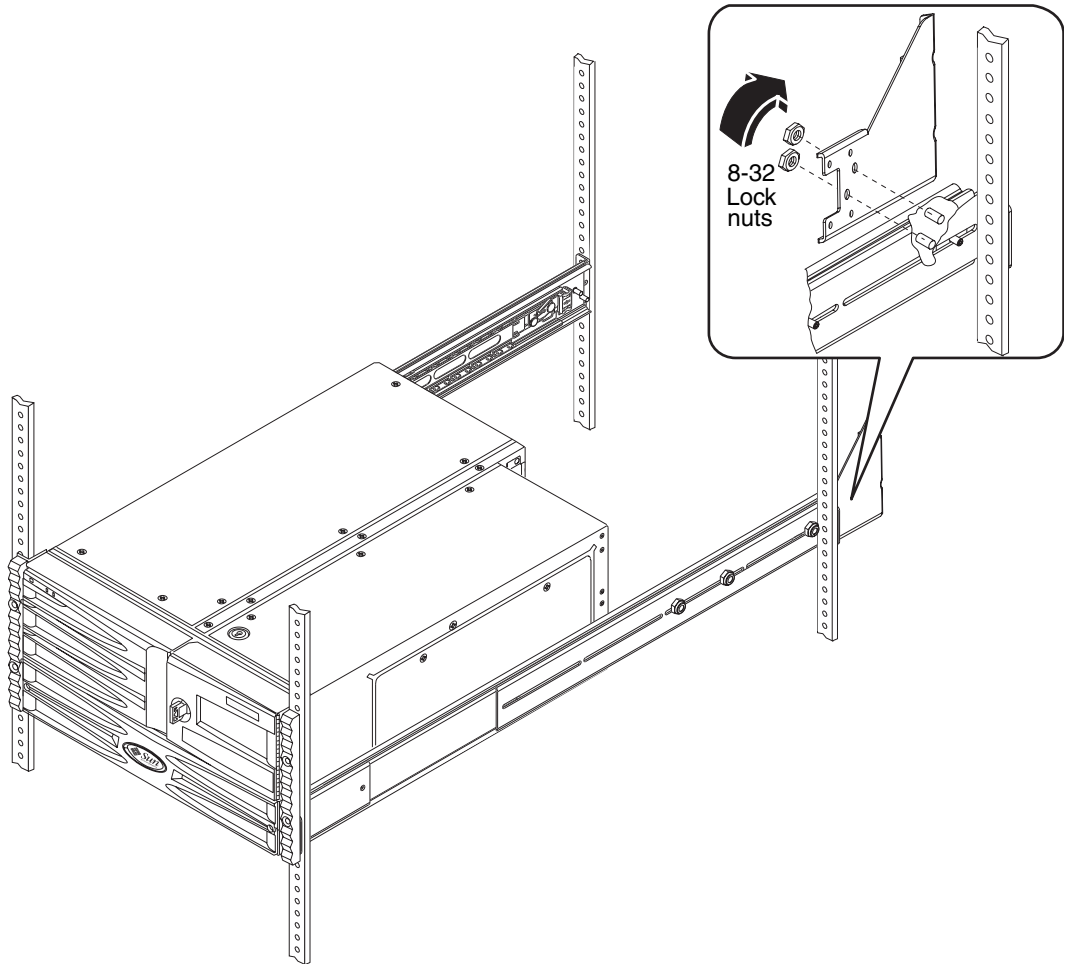

5. Attach the left hinge of the cable management arm to the hinged bracket on the slide assembly.

The cable management arm is included in the rack kit.

- a. Position the cable management arm so that the two metal fingers in the first section are facing the back of the server and the three metal fingers in the third section of the cable management arm are facing away from the server.
- b. Go to the back of the cabinet. Locate the hinged bracket on the left slide assembly as viewed from the rear.

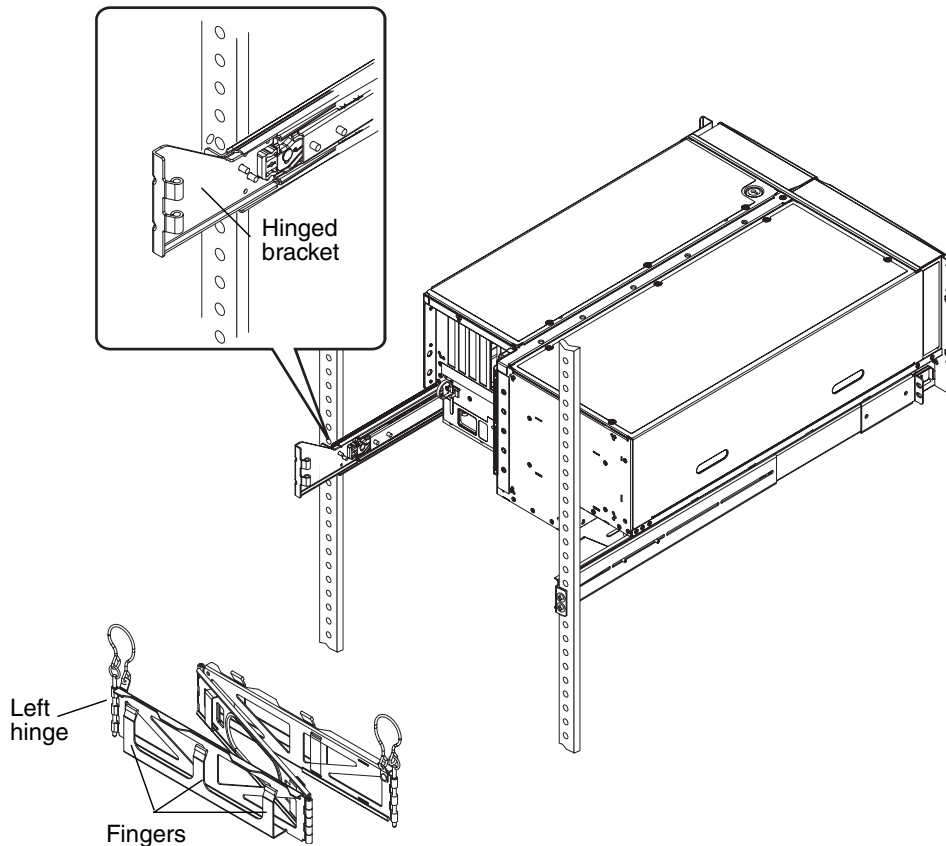

- c. Slide the hinge on the left side of the cable management arm into the hinge on the hinged bracket attached to the slide assembly until the openings in both hinges are aligned.

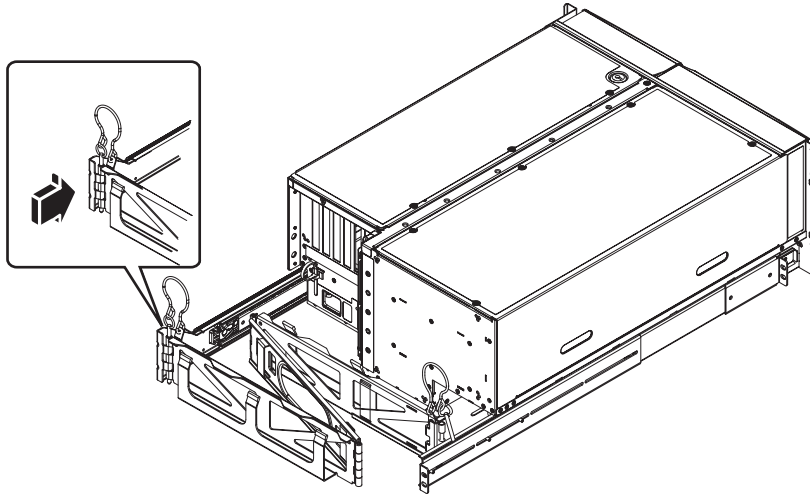

- d. **Locate the speed pin on the left side of the cable management arm.**
The speed pin secures the cable management arm to the slide assembly.
- e. **Insert the speed pin through the aligned openings of the hinges on the slide assembly and the cable management arm and push the speed pin down firmly.**

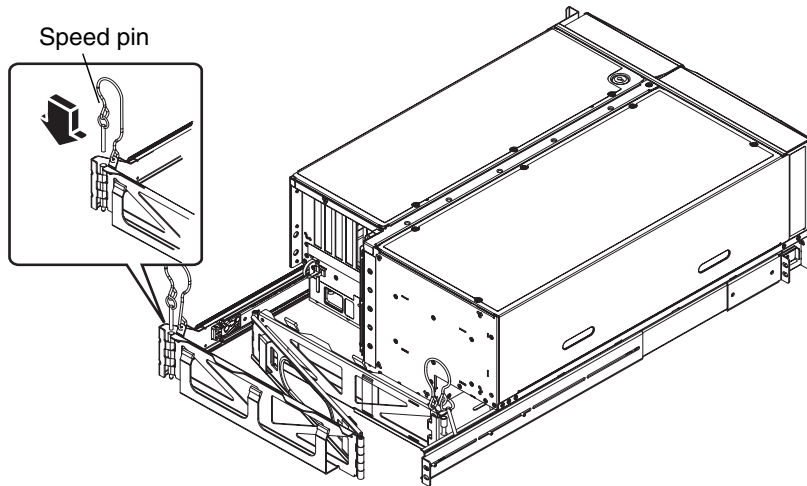

6. Attach the other end of the cable management arm to the hinged bracket on the inner glide on the right side of the chassis as viewed from the rear.
 - a. Locate the hinged bracket on the end of the inner glide.
 - b. Slide the hinge on the right side of the cable management arm into the hinge on the hinged bracket attached to the inner glide until the openings in both hinges are aligned.
 - c. Insert the speed pin through the aligned openings of the hinges on the bracket and the cable management arm and push the speed pin down firmly.

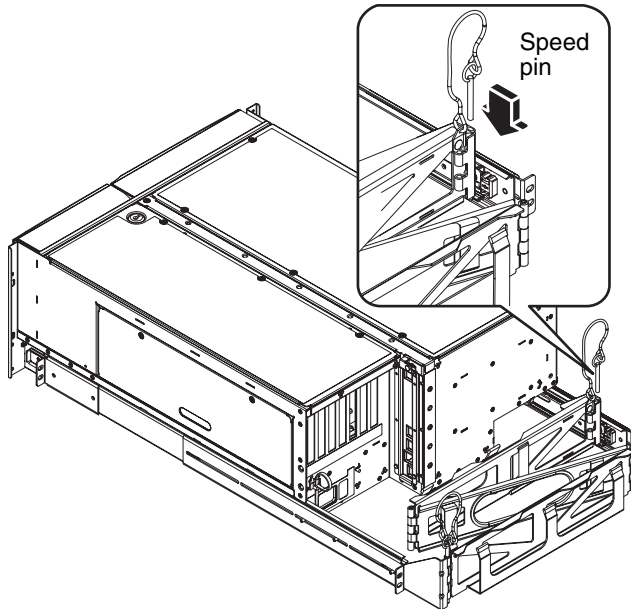

7. Connect the power cords and cables to the server ports. See [“Connect the Cords and Cables”](#) on page 40.

Note – Do not secure the server to the front mounting rails until after you route the cables onto the cable management arm. It is easier to route the cables onto the cable management arm when the server is retracted from the rack.

Connect the Cords and Cables

The following figure shows the Sun Fire V490 server back panel and identifies the AC power inlet and the I/O ports.

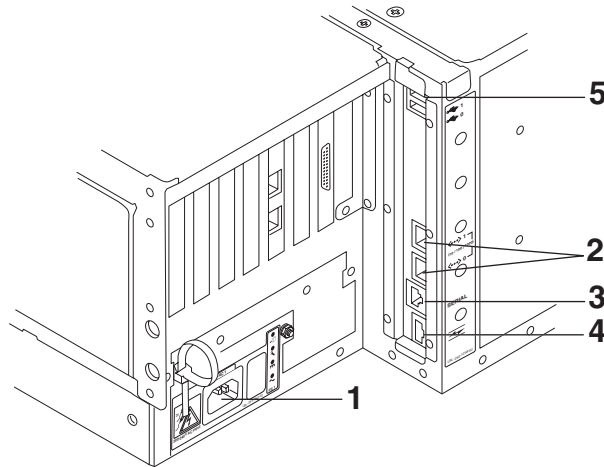
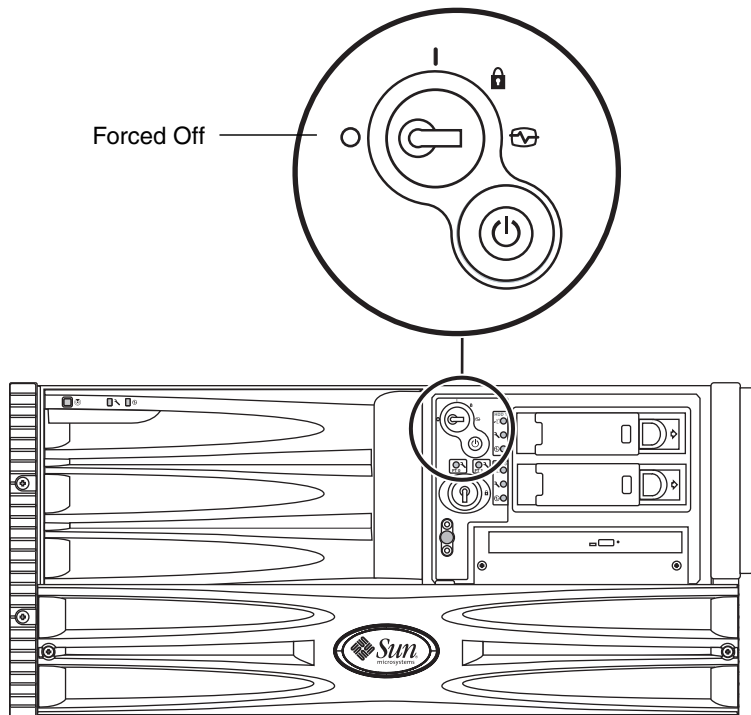

TABLE 3-1 Back Panel Ports

Back Panel Port	Information
1	One of two AC inlets for power cords Connect a power cord to each AC inlet. See “Connect the Power Cords” on page 41 . The V490 server uses 200-240 VAC line input only.
2	Ethernet ports Connect a TPE cable to at least one Ethernet port. See “Connect a Twisted-Pair Ethernet Cable” on page 44 .
3	Serial port Use this port to set up a tip connection or to connect an ASCII terminal. See the <i>Sun Fire V490 Server Administration Guide</i> for instructions. If you are connecting to an ASCII terminal, use an RJ-45 cable and the DB-25 adapter (Sun Part Number 530-2889-03) included in the ship kit.
4	HSSDC FC-AL port See the <i>Sun Fire V490 Server Administration Guide</i> for information about this port.
5	USB ports See the <i>Sun Fire V490 Server Administration Guide</i> for information about the devices you can connect to these ports.

Connect the Power Cords

1. Unlock and open the media door on the front panel.
2. Insert the system key into the system control switch on the front panel.
3. Turn the system control switch to the Forced Off position.



4. Connect an AC power cord to each AC inlet at the back of the server.
The Sun Fire V490 server uses 200-240 VAC line input only.

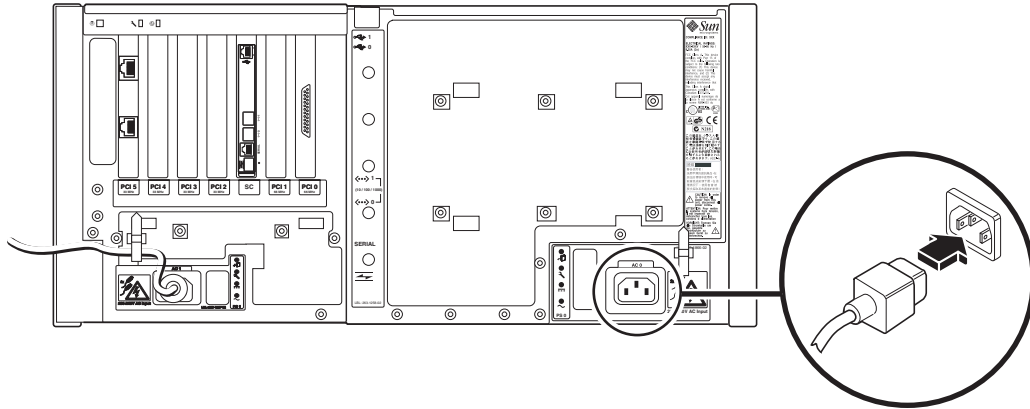

5. Attach a strain relief tie-wrap to each AC power cord.

Use the strain relief to prevent accidental or inadvertent removal of an AC power cord from its inlet. The strain relief is a plastic tie-wrap and pedestal that is inserted into the back panel of the server. Use these reliefs to manage the power cords after you have installed the cords into the AC inlets in the server.

To use a strain relief, press the tab to release the tie-wrap. Wrap the loose end of the tie-wrap around the AC power cord and thread the tie-wrap through the opening in the relief pedestal. Pull the end of the tie-wrap to tighten it.

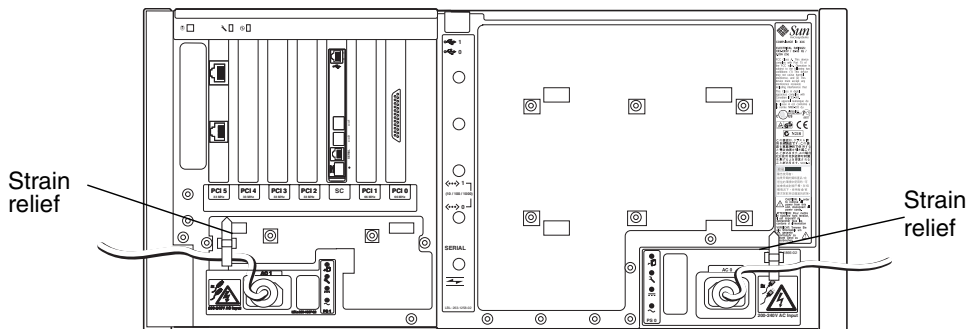

Connect a Twisted-Pair Ethernet Cable

Connect the twisted-pair Ethernet (TPE) cable to one of the Ethernet ports on the back panel. Each network interface configures itself automatically for either 10-Mbps, 100-Mbps, or 1000-Mbps operation depending on network characteristics.

1. Choose a network port, using the following table as a guide.

Ethernet Port	PCI Bus/Clock Rate	OBP Devalias	Device Path
1	PCI C/66 MHz	net1	/pci@9, 60000/network@1
0	PCI D/33 MHz	net0	/pci@9, 70000/network@2

Select the correct TPE connector for the interface you are installing. The server comes with two TPE connectors on the back panel and one on the system controller card.

Your server may also include one or more TPE connectors provided via PCI Ethernet interface cards.

2. Plug in a Category-5 unshielded twisted-pair (UTP) cable to the appropriate RJ-45 connector.

You should hear the connector tab snap into place. The UTP cable length must not exceed 328 feet (100 meters).

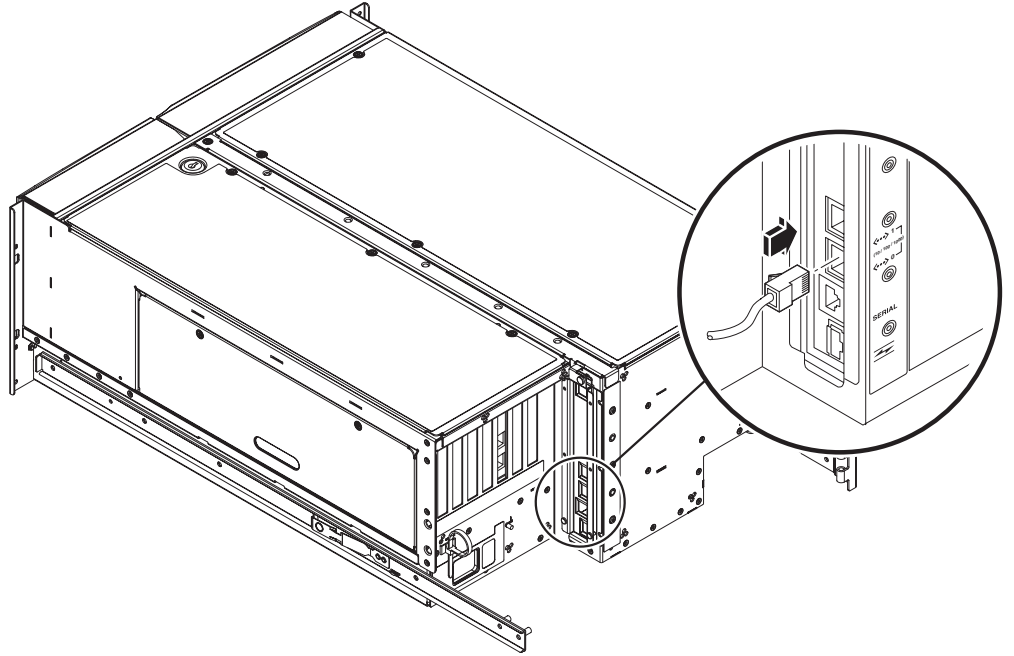

Secure the Cables to the Cable Management Arm

Note – This procedure illustrates how to route and secure the power cords and the Ethernet cable to the cable management arm. Your system may use additional cables.

1. **Install the cable management arm onto the server. See [“Install the Cable Management Arm” on page 33](#).**
2. **If necessary, slide the chassis smoothly out of the cabinet about 3 inches (7.62 cm).**
Sliding the server out of the cabinet provides easier access to the cable management arm.
3. **Locate the two metal fingers on the first section of the cable management arm and the three metal fingers on the third section of the cable management arm.**
Note the Velcro straps in the first and center sections.

4. Locate the large oval cutout in the center section of the cable management arm.

The fingers, oval cutout, and straps enable you to route the cables and cords and secure them to the cable management arm. A single power cord is shown in the figure below to indicate a routing path.

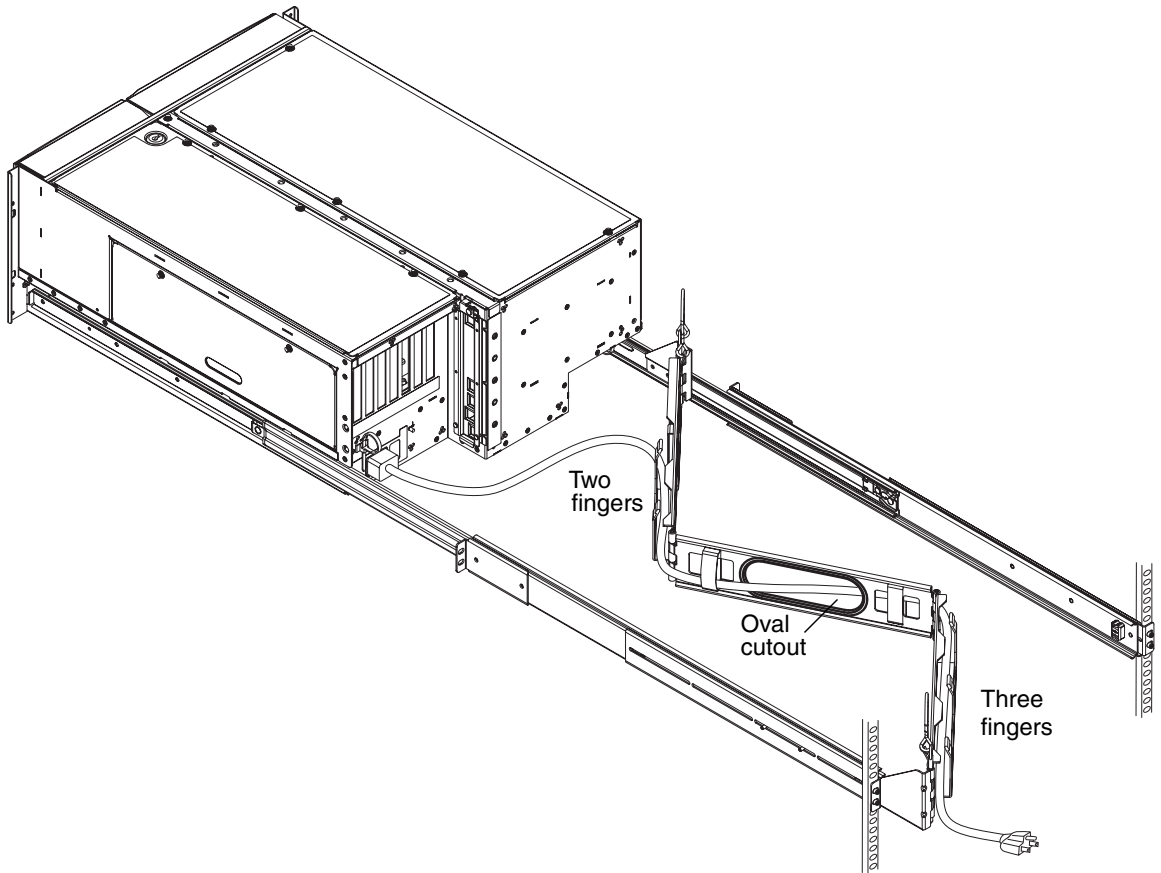

5. **Route the cables into the two fingers in the first section of the cable management arm.**

Be sure you leave enough slack to ensure an adequate bend radius for the cables.

6. **Group the cables and insert the group into the large oval cutout, as shown in the next figure.**

Use the oval cutout in the center section to route a group of cables through the cable management arm. Be sure you leave enough slack around the hinge to ensure an adequate bend radius for the cables.

Note – Do not insert the cables into the other metal cutouts. Use those cutouts to access and manipulate the cables.

7. **Route the cables into the three fingers in the third section of the cable management arm, as shown in the next figure.**
8. **Using the Velcro straps, secure the cords and cables to the first and center sections of the cable management arm.**

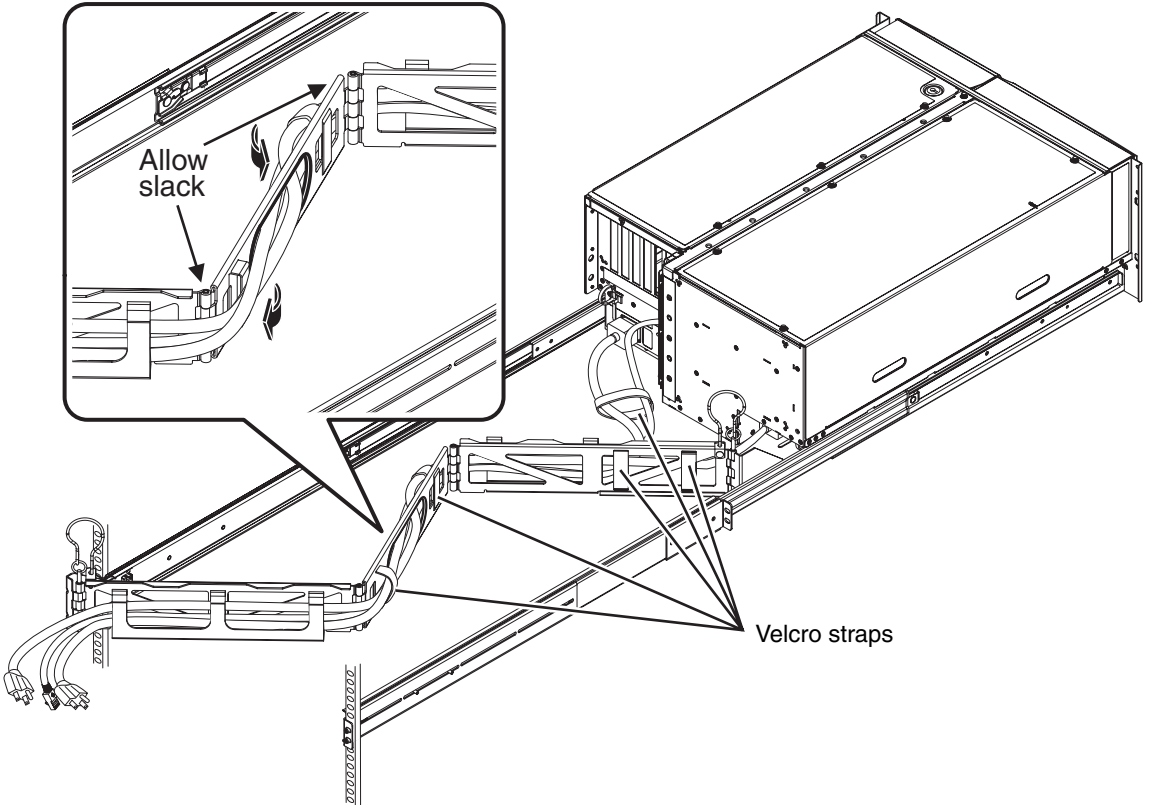

9. **Connect the outlet plug of each power cord to the power sequencer in the cabinet, or to a grounded AC power outlet.**

Note – Each outlet must connect the server to a 15A circuit for North America and Japan, and to a 10A circuit for Europe. Consult your local electrical codes for any additional requirements. See the instructions provide with your cabinet for information about the power sequencer.

Note – For increased server redundancy, connect the power cords to separate circuits.

10. **Plug in the TPE cable to the RJ-45 outlet to connect to your Ethernet network.**
See your network administrator if you need more information about how to connect to your network.
11. **Secure the server to the front vertical mounting rails using either four M6 screws or four 10-32 screws.**

Restore the Cabinet

See the instructions provided with your cabinet to complete these steps.

1. **Retract the cabinet's anti-tip legs, if applicable.**
2. **Replace the side panels, if applicable.**
3. **Replace the front and back doors, if applicable.**

What Next

The next step is to set up a system console, power on the server, and install the Solaris Operating System. See Part One of the *Sun Fire V490 Server Administration Guide* or the *Sun Fire V490 Quick Start Guide* to continue the installation procedure.

4-Post Cabinet Requirements

The server is designed so that you can install it into a 72-inch (184-cm) tall Sun expansion cabinet or other EIA-compliant industry-standard cabinet that meets the requirements listed in the table in this appendix. You need a Sun rack kit for each server that you rackmount.

For more detailed information about rack options and requirements, and site planning for cabinets and racks, see the *Site Planning Guide for Entry-Level Servers Version 1.5*. This guide is available at:

<http://www.sun.com/documentation>

Note – The system is fully serviceable in a 4-post cabinet when it is extended on its slide assemblies.

TABLE A-1 4-Post Rack Requirements

Cabinet Feature	Requirement
Load-bearing capacity	The rack must firmly support the weight of as many Sun Fire V490 servers as you are installing into the cabinet (each server weighs up to 97 lb/44 kg), plus the weight of the rackmounting hardware, and the weight of any other installed devices.
Vertical space requirements	Each server requires five rack units (8.75 in/22.22 cm) of vertical space for rack installation. A 72-inch (184-cm) Sun cabinet ships with a power sequencer so that it can hold up to seven servers (with a power sequencer there are 36 rack units of usable space). Note: If the servers are fully populated, the cabinet and power sequencer will only support six servers. See the <i>Site Planning Guide for Entry-Level Servers Version 1.5</i> for more information.
Doors and panels	If you are using a Sun expansion cabinet, you can remove the front and back doors and the side panels to increase access to the system. Otherwise, see the instructions provided with the cabinet.
Anti-tip protection	The cabinet must be bolted securely to the floor or equipped with two sturdy and extendable anti-tip legs. You must prevent the cabinet from tilting forward when one or more systems or devices are fully extended out the front of the cabinet.

TABLE A-1 4-Post Rack Requirements (*Continued*)

Cabinet Feature	Requirement
Airflow	<p>The system operating airflow is 200 cfm, regardless of ambient air and altitude. This airflow is designed to provide appropriate cooling up to 95° F (35° C) and 10,000 feet (3.0480 meters).</p> <p>For proper ventilation of the server, the front and back doors must comply with the following minimum open area requirements.</p> <ul style="list-style-type: none">• 60 percent of the area of the front door that is directly in front of the server must be open.• 63 percent of the area of the back door that is directly behind the server must be open.• Maintain a minimum of 1.5-inch (3.8-cm) clearance between the system and any front or back doors. <p>If the doors of the cabinet do not meet the open area requirements, remove the door or doors that do not comply.</p> <p>For more information about cooling and airflow, see the <i>Site Planning Guide for Entry-Level Servers Version 1.5</i>.</p>
Vertical mounting rails	<p>The cabinet must have two pairs of vertical mounting rails (one pair in front, one pair in back) that conform to the EIA (RETMA) standard for mounting hole spacing.</p> <p>Left-side-to-right-side rail spacing (mounting hole center to mounting hole center) for front and back rails must be 18.3 inches (46.5 cm).</p> <p>Front-to-back rail spacing must be at least 23 inches (58.42 cm) and not more than 34.5 inches (87.63 cm) from the outside face of the front rail to the outside face of the back rail.</p> <p>Front and back vertical rail mounting faces must be parallel with each other and with the front plane of the rack.</p>

TABLE A-1 4-Post Rack Requirements (*Continued*)

Cabinet Feature	Requirement
EMI shielding	Electromagnetic interference (EMI) shielding requirements are met by the system chassis and metal side panels, which remain in place when the unit is rackmounted.
Minimum service access	An area not less than 3 feet (1 meter) deep and 6 feet (2 meters) wide must be available in front of the cabinet, for installation and service access.
Fire containment	The cabinet must meet Underwriters Laboratories, Inc. and TUV Rheinland of N.A. requirements for fire containment.