

# Sun Fire™ E2900/V1280 and Netra™ 1280 Systems 23-Inch Two-Post Rack Adapter Installation Guide

---

To install a Sun Fire E2900/V1280 or Netra 1280 system into a 23-inch rack, use a pair of adapter brackets. The brackets reduce the distance between the mounting points to 19 inches.

## Installing the Rack Adapter Brackets

- ◆ **Secure the rack adapter brackets to the posts using four screws for each bracket.**

Mount the brackets at least 10 inches (25.4 cm) from the floor.

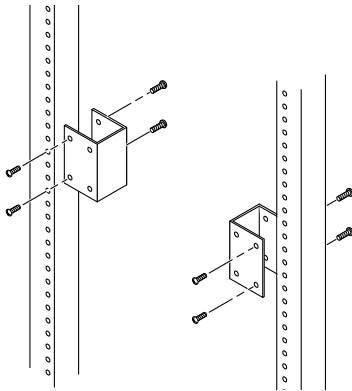

---

**Note** – After installing the brackets, use the instructions that apply to a 19-inch two-post rack to install the system in the rack. Refer to the system installation guide for your product.

---

## Accessing Sun Documentation

You can view, print, or purchase a broad selection of Sun documentation, including localized versions, at:

<http://www.sun.com/documentation>

## Contacting Sun Technical Support

If you have technical questions about this product that are not answered in this document, go to:

<http://www.sun.com/service/contacting>

## Sun Welcomes Your Comments

Sun is interested in improving its documentation and welcomes your comments and suggestions. You can submit your comments by going to:

<http://www.sun.com/hwdocs/feedback>

Please include the title and part number of your document with your feedback:

*Sun Fire E2900/V1280 and Netra 1280 Systems Two-Post Rack Adapter Installation Guide*, part number 817-2682-11

Copyright 2004 Sun Microsystems, Inc. All rights reserved. Use is subject to license terms. Third-party software, including font technology, is copyrighted and licensed from Sun suppliers. Portions may be derived from Berkeley BSD systems, licensed from U. of CA. Sun, Sun Microsystems, the Sun logo, Sun Fire, Netra, and Solaris are trademarks or registered trademarks of Sun Microsystems, Inc. in the U.S. and in other countries. All SPARC trademarks are used under license and are trademarks or registered trademarks of SPARC International, Inc. in the U.S. and in other countries. U.S. Government Rights—Commercial use. Government users are subject to the Sun Microsystems, Inc. standard license agreement and applicable provisions of the FAR and its supplements.

Copyright 2004 Sun Microsystems, Inc. Tous droits réservés. Distribué par des licences qui en restreignent l'utilisation. Le logiciel détenu par des tiers, et qui comprend la technologie relative aux polices de caractères, est protégé par un copyright et licencié par des fournisseurs de Sun. Des parties de ce produit pourront être dérivées des systèmes Berkeley BSD licenciés par l'Université de Californie. Sun, Sun Microsystems, le logo Sun, Sun Fire, Netra, et Solaris sont des marques de fabrique ou des marques déposées de Sun Microsystems, Inc. aux Etats-Unis et dans d'autres pays. Toutes les marques SPARC sont utilisées sous licence et sont des marques de fabrique ou des marques déposées de SPARC International, Inc. aux Etats-Unis et dans d'autres pays.



Sun Microsystems, Inc.  
[www.sun.com](http://www.sun.com)