



Sun Fire™ E2900/V1280 and Netra™ 1280 Systems Tape Drive Installation Guide



Caution – Use proper ESD grounding techniques when handling components. Wear an antistatic wrist strap and use an ESD-protected mat. Store ESD-sensitive components in ESD-safe packaging before placing them on any surface.

Installing the Tape Drive

The tape drive is not a hot-swappable device.

1. **Take the system to Standby mode or halt the Solaris Operating System).**
Refer to your system's service manual or system administration manual.
2. **Remove the existing tape drive or tape drive filler panel from the removeable media module.**
For detailed instructions, refer to your system's service manual.

Note – The tape drive is not shipped with a base plate installed. Install a base plate on the tape drive as described below.

3. **Remove the base plate from the existing tape drive or tape drive filler panel.**
As shown below, there are four screws that secure the base plate to a tape drive, or two screws that secure the base plate to a tape drive filler panel.

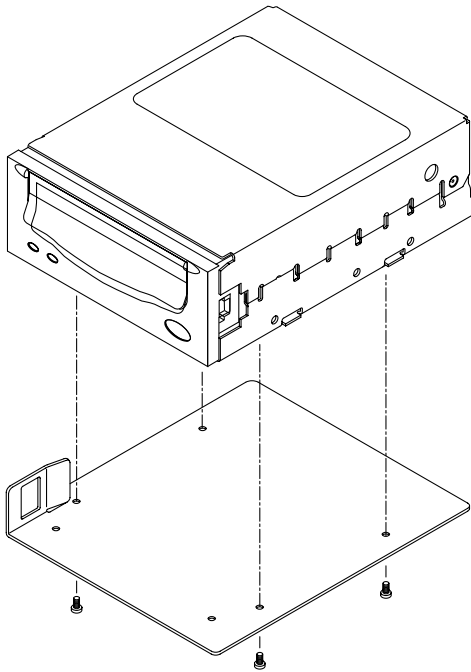

FIGURE 1 Tape Drive and Base Plate

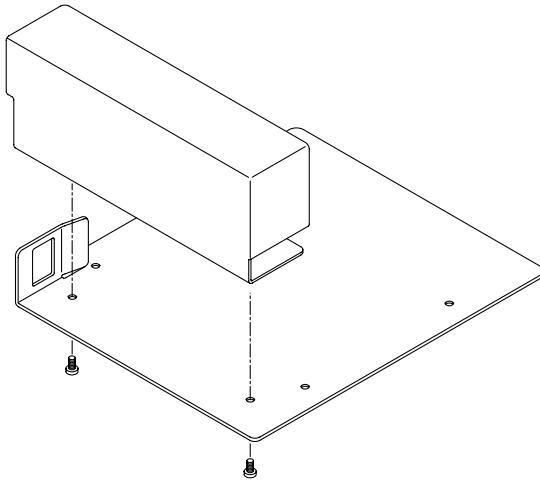

FIGURE 2 Tape Drive Filler Panel and Base Plate

- 4. Attach the base plate to the new tape drive using the four countersunk screws that were shipped with the drive.**
- 5. Install the new tape drive in the removeable media module.**
- 6. Reattach the data and power cables to the tape drive.**
- 7. Close the chassis.**
For detailed instructions, refer to your system's service manual.
- 8. Restart the system.**

Accessing Sun Documentation

You can view, print, or purchase a broad selection of Sun documentation, including localized versions, at:

<http://www.sun.com/documentation>

Contacting Sun Technical Support

If you have technical questions about this product that are not answered in this document, go to:

<http://www.sun.com/service/contacting>

Sun Welcomes Your Comments

Sun is interested in improving its documentation and welcomes your comments and suggestions. You can submit your comments by going to:

<http://www.sun.com/hwdocs/feedback>

Please include the title and part number of your document with your feedback:

Sun Fire E2900/V1280 and Netra 1280 Systems Tape Drive Installation Guide, part number 817-2677-11

Copyright 2004 Sun Microsystems, Inc. All rights reserved. Use is subject to license terms. Third-party software, including font technology, is copyrighted and licensed from Sun suppliers. Portions may be derived from Berkeley BSD systems, licensed from U. of CA. Sun, Sun Microsystems, the Sun logo, Sun Fire, Netra, and Solaris are trademarks or registered trademarks of Sun Microsystems, Inc. in the U.S. and in other countries. All SPARC trademarks are used under license and are trademarks or registered trademarks of SPARC International, Inc. in the U.S. and in other countries. U.S. Government Rights—Commercial use. Government users are subject to the Sun Microsystems, Inc. standard license agreement and applicable provisions of the FAR and its supplements.

Copyright 2004 Sun Microsystems, Inc. Tous droits réservés. Distribué par des licences qui en restreignent l'utilisation. Le logiciel détenu par des tiers, et qui comprend la technologie relative aux polices de caractères, est protégé par un copyright et licencié par des fournisseurs de Sun. Des parties de ce produit pourront être dérivées des systèmes Berkeley BSD licenciés par l'Université de Californie. Sun, Sun Microsystems, le logo Sun, Sun Fire, Netra, et Solaris sont des marques de fabrique ou des marques déposées de Sun Microsystems, Inc. aux Etats-Unis et dans d'autres pays. Toutes les marques SPARC sont utilisées sous licence et sont des marques de fabrique ou des marques déposées de SPARC International, Inc. aux Etats-Unis et dans d'autres pays.



Sun Microsystems, Inc.
www.sun.com