



Sun Fire™ 6800/4810/4800/3800 Systems Installation Guide

Sun Microsystems, Inc.
www.sun.com

Part No. 817-2353-12
April 2004, Revision A

Submit comments about this document at: <http://www.sun.com/hwdocs/feedback>

Copyright 2004 Sun Microsystems, Inc., 4150 Network Circle, Santa Clara, California 95054, U.S.A. All rights reserved.

Sun Microsystems, Inc. has intellectual property rights relating to technology embodied in the product that is described in this document. In particular, and without limitation, these intellectual property rights may include one or more of the U.S. patents listed at <http://www.sun.com/patents> and one or more additional patents or pending patent applications in the U.S. and in other countries.

This document and the product to which it pertains are distributed under licenses restricting their use, copying, distribution, and decompilation. No part of the product or of this document may be reproduced in any form by any means without prior written authorization of Sun and its licensors, if any.

Third-party software, including font technology, is copyrighted and licensed from Sun suppliers.

Parts of the product may be derived from Berkeley BSD systems, licensed from the University of California. UNIX is a registered trademark in the U.S. and in other countries, exclusively licensed through X/Open Company, Ltd.

Sun, Sun Microsystems, the Sun logo, AnswerBook2, docs.sun.com, and Solaris are trademarks or registered trademarks of Sun Microsystems, Inc. in the U.S. and in other countries.

All SPARC trademarks are used under license and are trademarks or registered trademarks of SPARC International, Inc. in the U.S. and in other countries. Products bearing SPARC trademarks are based upon an architecture developed by Sun Microsystems, Inc.

The OPEN LOOK and Sun™ Graphical User Interface was developed by Sun Microsystems, Inc. for its users and licensees. Sun acknowledges the pioneering efforts of Xerox in researching and developing the concept of visual or graphical user interfaces for the computer industry. Sun holds a non-exclusive license from Xerox to the Xerox Graphical User Interface, which license also covers Sun's licensees who implement OPEN LOOK GUIs and otherwise comply with Sun's written license agreements.

U.S. Government Rights—Commercial use. Government users are subject to the Sun Microsystems, Inc. standard license agreement and applicable provisions of the FAR and its supplements.

DOCUMENTATION IS PROVIDED "AS IS" AND ALL EXPRESS OR IMPLIED CONDITIONS, REPRESENTATIONS AND WARRANTIES, INCLUDING ANY IMPLIED WARRANTY OF MERCHANTABILITY, FITNESS FOR A PARTICULAR PURPOSE OR NON-INFRINGEMENT, ARE DISCLAIMED, EXCEPT TO THE EXTENT THAT SUCH DISCLAIMERS ARE HELD TO BE LEGALLY INVALID.

Copyright 2004 Sun Microsystems, Inc., 4150 Network Circle, Santa Clara, California 95054, Etats-Unis. Tous droits réservés.

Sun Microsystems, Inc. a les droits de propriété intellectuelle relatant à la technologie incorporée dans le produit qui est décrit dans ce document. En particulier, et sans la limitation, ces droits de propriété intellectuelle peuvent inclure un ou plus des brevets américains énumérés à <http://www.sun.com/patents> et un ou les brevets plus supplémentaires ou les applications de brevet en attente dans les Etats-Unis et dans les autres pays.

Ce produit ou document est protégé par un copyright et distribué avec des licences qui en restreignent l'utilisation, la copie, la distribution, et la décompilation. Aucune partie de ce produit ou document ne peut être reproduite sous aucune forme, par quelque moyen que ce soit, sans l'autorisation préalable et écrite de Sun et de ses bailleurs de licence, s'il y en a.

Le logiciel détenu par des tiers, et qui comprend la technologie relative aux polices de caractères, est protégé par un copyright et licencié par des fournisseurs de Sun.

Des parties de ce produit pourront être dérivées des systèmes Berkeley BSD licenciés par l'Université de Californie. UNIX est une marque déposée aux Etats-Unis et dans d'autres pays et licenciée exclusivement par X/Open Company, Ltd.

Sun, Sun Microsystems, le logo Sun, AnswerBook2, docs.sun.com, et Solaris sont des marques de fabrique ou des marques déposées de Sun Microsystems, Inc. aux Etats-Unis et dans d'autres pays.

Toutes les marques SPARC sont utilisées sous licence et sont des marques de fabrique ou des marques déposées de SPARC International, Inc. aux Etats-Unis et dans d'autres pays. Les produits portant les marques SPARC sont basés sur une architecture développée par Sun Microsystems, Inc.

L'interface d'utilisation graphique OPEN LOOK et Sun™ a été développée par Sun Microsystems, Inc. pour ses utilisateurs et licenciés. Sun reconnaît les efforts de pionniers de Xerox pour la recherche et le développement du concept des interfaces d'utilisation visuelle ou graphique pour l'industrie de l'informatique. Sun détient une licence non exclusive de Xerox sur l'interface d'utilisation graphique Xerox, cette licence couvrant également les licenciées de Sun qui mettent en place l'interface d'utilisation graphique OPEN LOOK et qui en outre se conforment aux licences écrites de Sun.

LA DOCUMENTATION EST FOURNIE "EN L'ÉTAT" ET TOUTES AUTRES CONDITIONS, DECLARATIONS ET GARANTIES EXPRESSES OU TACITES SONT FORMELLEMENT EXCLUES, DANS LA MESURE AUTORISÉE PAR LA LOI APPLICABLE, Y COMPRIS NOTAMMENT TOUTE GARANTIE IMPLICITE RELATIVE A LA QUALITE MARCHANDE, A L'APTITUDE A UNE UTILISATION PARTICULIERE OU A L'ABSENCE DE CONTREFAÇON.



Contents

Preface xxix

Typographic Conventions xxix

Related Documentation xxx

Accessing Sun Documentation xxx

Sun Welcomes Your Comments xxx

Contacting Sun Technical Support xxxi

Cautions and Notes xxxi

1. Preparing for Installation 1-1

1.1 Verifying the Electrical Circuits 1-1

1.2 Verifying the Air Conditioning 1-2

1.3 Verifying the Floor Area 1-3

2. Installing the Sun Fire 6800 System 2-1

2.1 Tools 2-1

2.2 Unpacking the Sun Fire 6800 System 2-2

2.3 Moving and Securing the Sun Fire 6800 System 2-3

2.3.1 Adjusting the Leveling Pads 2-6

2.3.2 Securing the Cabinet to the Floor 2-6

2.3.3 Shipping and Storing the System 2-7

- 2.4 Connecting Power Cables to the Sun Fire 6800 System 2-8
- 2.5 Connecting the I/O Assemblies 2-11
- 2.6 Connecting the Administrative Console 2-12
 - 2.6.1 Connecting the ASCII terminal 2-13
 - 2.6.2 Connecting the Administrative Console 2-13
- 2.7 Powering On the Sun Fire 6800 System 2-14
- 2.8 Powering Off the Sun Fire 6800 System 2-16
- 2.9 Installing Additional Hardware 2-16
- 2.10 Installing Peripheral Devices 2-17

- 3. Installing the Sun Fire 4810 System 3-1**
 - 3.1 Mounting a Sun Fire 4810 System 3-1
 - 3.2 Connecting Power Cables 3-2
 - 3.3 Connecting the I/O Assemblies 3-2
 - 3.4 Connecting the Administrative Console 3-4
 - 3.4.1 Connecting the ASCII terminal 3-5
 - 3.4.2 Connecting the Administrative Console 3-5
 - 3.5 Powering On the Sun Fire 4810 System 3-6
 - 3.6 Powering Off the Sun Fire 4810 System 3-6
 - 3.7 Installing Additional Hardware 3-6
 - 3.8 Installing Peripheral Devices 3-7
 - 3.9 cPCI Card Visibility Issues 3-7

- 4. Installing the Sun Fire 4800 System 4-1**
 - 4.1 Mounting a Sun Fire 4800 System 4-1
 - 4.2 Connecting Power Cables to the Sun Fire 4800 System 4-2
 - 4.3 Connecting the I/O Assemblies 4-2
 - 4.4 Connecting the Administrative Console 4-4
 - 4.4.1 Connecting the ASCII terminal 4-5

4.4.2	Connecting the Administrative Console	4-5
4.5	Powering On the Sun Fire 4800 System	4-6
4.6	Powering Off the Sun Fire 4800 System	4-6
4.7	Installing Additional Hardware	4-6
4.8	Installing Peripheral Devices	4-7
4.9	cPCI Card Visibility Issues	4-7
5.	Installing the Sun Fire 3800 System	5-1
5.1	Mounting a Sun Fire 3800 System	5-1
5.2	Connecting Power Cables to the Sun Fire 3800 System	5-2
5.3	Connecting the I/O Assemblies	5-2
5.4	Connecting the Administrative Console	5-4
5.4.1	Connecting the ASCII terminal	5-5
5.4.2	Connecting the Administrative Console	5-5
5.5	Powering On the Sun Fire 3800 System	5-6
5.6	Powering Off the Sun Fire 3800 System	5-6
5.7	Installing Additional Hardware	5-6
5.8	Installing Peripheral Devices	5-7
5.9	cPCI Card Visibility Issues	5-7

Figures

- [FIGURE 1-1](#) Sun Fire System Access Areas—Top View 1–3
- [FIGURE 2-1](#) Unpacking the Sun Fire 6800 System—Step 1 2–2
- [FIGURE 2-2](#) Unpacking the Sun Fire 6800 System—Step 2 2–2
- [FIGURE 2-3](#) Front Brackets and Front Wheel Stop 2–3
- [FIGURE 2-4](#) Removing the Rear Brackets and Rear Wheel Stop and Positioning Ramps 2–4
- [FIGURE 2-5](#) Moving the Sun Fire 6800 System Off the Shipping Pallet 2–5
- [FIGURE 2-6](#) Bracketing the Sun Fire 6800 System to the floor 2–7
- [FIGURE 2-7](#) RTS AC Power Switch on the Sun Fire 6800 System 2–8
- [FIGURE 2-8](#) Two Independent AC Power Sources 2–9
- [FIGURE 2-9](#) One AC Power Source 2–9
- [FIGURE 2-10](#) Connecting Power Cables to the RTS Module 2–10
- [FIGURE 2-11](#) Primary TTYa Serial Port and Primary Ethernet Connections on the Patch Panel 2–12
- [FIGURE 2-12](#) Serial Cable Connections 2–13
- [FIGURE 2-13](#) Sun Fire 6800 System Power Switch Locations 2–15
- [FIGURE 2-14](#) FrameManager Location—Front View 2–15
- [FIGURE 3-1](#) Power Switch, Power Cord Socket and I/O Assembly Locations on the Sun Fire 4810 System 3–3
- [FIGURE 3-2](#) Primary System Controller Connections on the Sun Fire 4810 System 3–4
- [FIGURE 3-3](#) Serial Cable Connections 3–5
- [FIGURE 4-1](#) Power Switch, Power Cord Socket and I/O Assembly Locations on the Sun Fire 4800 System 4–3

- FIGURE 4-2** Primary System Controller Connections on the Sun Fire 4800 System 4-4
- FIGURE 4-3** Serial Cable Connections 4-5
- FIGURE 5-1** Power Switch and Power Cord Socket Locations on the Sun Fire 3800 System 5-3
- FIGURE 5-2** System Controller and I/O Assembly Locations on the Sun Fire 3800 System 5-4
- FIGURE 5-3** Serial Cable Connections 5-5

Regulatory Compliance Statements

Your Sun product is marked to indicate its compliance class:

- Federal Communications Commission (FCC) — USA
- Industry Canada Equipment Standard for Digital Equipment (ICES-003) — Canada
- Voluntary Control Council for Interference (VCCI) — Japan
- Bureau of Standards Metrology and Inspection (BSMI) — Taiwan

Please read the appropriate section that corresponds to the marking on your Sun product before attempting to install the product.

FCC Class A Notice

This device complies with Part 15 of the FCC Rules. Operation is subject to the following two conditions:

1. This device may not cause harmful interference.
2. This device must accept any interference received, including interference that may cause undesired operation.

Note: This equipment has been tested and found to comply with the limits for a Class A digital device, pursuant to Part 15 of the FCC Rules. These limits are designed to provide reasonable protection against harmful interference when the equipment is operated in a commercial environment. This equipment generates, uses, and can radiate radio frequency energy, and if it is not installed and used in accordance with the instruction manual, it may cause harmful interference to radio communications. Operation of this equipment in a residential area is likely to cause harmful interference, in which case the user will be required to correct the interference at his own expense.

Modifications: Any modifications made to this device that are not approved by Sun Microsystems, Inc. may void the authority granted to the user by the FCC to operate this equipment.

FCC Class B Notice

This device complies with Part 15 of the FCC Rules. Operation is subject to the following two conditions:

1. This device may not cause harmful interference.
2. This device must accept any interference received, including interference that may cause undesired operation.

Note: This equipment has been tested and found to comply with the limits for a Class B digital device, pursuant to Part 15 of the FCC Rules. These limits are designed to provide reasonable protection against harmful interference in a residential installation. This equipment generates, uses and can radiate radio frequency energy and, if not installed and used in accordance with the instructions, may cause harmful interference to radio communications. However, there is no guarantee that interference will not occur in a particular installation. If this equipment does cause harmful interference to radio or television reception, which can be determined by turning the equipment off and on, the user is encouraged to try to correct the interference by one or more of the following measures:

- Reorient or relocate the receiving antenna.
- Increase the separation between the equipment and receiver.
- Connect the equipment into an outlet on a circuit different from that to which the receiver is connected.
- Consult the dealer or an experienced radio/television technician for help.

Modifications: Any modifications made to this device that are not approved by Sun Microsystems, Inc. may void the authority granted to the user by the FCC to operate this equipment.

ICES-003 Class A Notice - Avis NMB-003, Classe A

This Class A digital apparatus complies with Canadian ICES-003.

Cet appareil numérique de la classe A est conforme à la norme NMB-003 du Canada.

ICES-003 Class B Notice - Avis NMB-003, Classe B

This Class B digital apparatus complies with Canadian ICES-003.

Cet appareil numérique de la classe B est conforme à la norme NMB-003 du Canada.

VCCI 基準について

クラス A VCCI 基準について

クラス A VCCI の表示があるワークステーションおよびオプション製品は、クラス A 情報技術装置です。これらの製品には、下記の項目が該当します。

この装置は、情報処理装置等電波障害自主規制協議会 (VCCI) の基準に基づくクラス A 情報技術装置です。この装置を家庭環境で使用すると電波妨害を引き起こすことがあります。この場合には使用者が適切な対策を講ずるよう要求されることがあります。

クラス B VCCI 基準について

クラス B VCCI の表示  があるワークステーションおよびオプション製品は、クラス B 情報技術装置です。これらの製品には、下記の項目が該当します。

この装置は、情報処理装置等電波障害自主規制協議会 (VCCI) の基準に基づくクラス B 情報技術装置です。この装置は、家庭環境で使用することを目的としていますが、この装置がラジオやテレビジョン受信機に近接して使用されると、受信障害を引き起こすことがあります。取扱説明書に従って正しい取り扱いをしてください。

BSMI Class A Notice

The following statement is applicable to products shipped to Taiwan and marked as Class A on the product compliance label.

警告使用者：
這是甲類的資訊產品，在居住的環境中使用時，可能會造成射頻干擾，在這種情況下，使用者會被要求採取某些適當的對策。



GOST-R Certification Mark

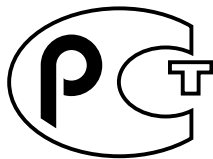

Safety Agency Compliance Statements

Read this section before beginning any procedure. The following text provides safety precautions to follow when installing a Sun Microsystems product.

Safety Precautions

For your protection, observe the following safety precautions when setting up your equipment:

- Follow all cautions and instructions marked on the equipment.
- Ensure that the voltage and frequency of your power source match the voltage and frequency inscribed on the equipment's electrical rating label.
- Never push objects of any kind through openings in the equipment. Dangerous voltages may be present. Conductive foreign objects could produce a short circuit that could cause fire, electric shock, or damage to your equipment.

Symbols

The following symbols may appear in this book:



Caution – There is a risk of personal injury and equipment damage. Follow the instructions.



Caution – Hot surface. Avoid contact. Surfaces are hot and may cause personal injury if touched.



Caution – Hazardous voltages are present. To reduce the risk of electric shock and danger to personal health, follow the instructions.

Depending on the type of power switch your device has, one of the following symbols may be used:



On – Applies AC power to the system.



Off – Removes AC power from the system.



Standby – The On/Standby switch is in the standby position.

Modifications to Equipment

Do not make mechanical or electrical modifications to the equipment. Sun Microsystems is not responsible for regulatory compliance of a modified Sun product.

Placement of a Sun Product



Caution – Do not block or cover the openings of your Sun product. Never place a Sun product near a radiator or heat register. Failure to follow these guidelines can cause overheating and affect the reliability of your Sun product.

Noise Level

In compliance with the requirements defined in DIN 45635 Part 1000, the workplace-dependent noise level of this product is less than 70 db(A).

SELV Compliance

Safety status of I/O connections comply to SELV requirements.

Power Cord Connection



Caution – Sun products are designed to work with power systems having a grounded neutral (grounded return for DC-powered products). To reduce the risk of electric shock, do not plug Sun products into any other type of power system. Contact your facilities manager or a qualified electrician if you are not sure what type of power is supplied to your building.



Caution – Not all power cords have the same current ratings. Household extension cords do not have overload protection and are not meant for use with computer systems. Do not use household extension cords with your Sun product.

The following caution applies only to devices with a Standby power switch:



Caution – The power switch of this product functions as a standby type device only. The power cord serves as the primary disconnect device for the system. Be sure to plug the power cord into a grounded power outlet that is nearby the system and is readily accessible. Do not connect the power cord when the power supply has been removed from the system chassis.

The following caution applies only to devices with multiple power cords:



Caution – For products with multiple power cords, all power cords must be disconnected to completely remove power from the system.

Battery Warning



Caution – There is danger of explosion if batteries are mishandled or incorrectly replaced. On systems with replaceable batteries, replace only with the same manufacturer and type or equivalent type recommended by the manufacturer per the instructions provided in the product service manual. Do not disassemble batteries or attempt to recharge them outside the system. Do not dispose of batteries in fire. Dispose of batteries properly in accordance with the manufacturer's instructions and local regulations. Note that on Sun CPU boards, there is a lithium battery molded into the real-time clock. These batteries are not customer replaceable parts.

System Unit Cover

You must remove the cover of your Sun computer system unit to add cards, memory, or internal storage devices. Be sure to replace the cover before powering on your computer system.



Caution – Do not operate Sun products without the cover in place. Failure to take this precaution may result in personal injury and system damage.

Rack System Warning

The following warnings apply to Racks and Rack Mounted systems.



Caution – For safety, equipment should always be loaded from the bottom up. That is, install the equipment that will be mounted in the lowest part of the rack first, then the next higher systems, etc.



Caution – To prevent the rack from tipping during equipment installation, the anti-tilt bar on the rack must be deployed.



Caution – To prevent extreme operating temperature within the rack insure that the maximum temperature does not exceed the product's ambient rated temperatures.



Caution – To prevent extreme operating temperatures due to reduced airflow consideration should be made to the amount of air flow that is required for a safe operation of the equipment.

Laser Compliance Notice

Sun products that use laser technology comply with Class 1 laser requirements.

Class 1 Laser Product
Luokan 1 Laserlaite
Klasse 1 Laser Apparat
Laser Klasse 1

CD and DVD Devices

The following caution applies to CD, DVD, and other optical devices.



Caution – Use of controls, adjustments, or the performance of procedures other than those specified herein may result in hazardous radiation exposure.

Conformité aux normes de sécurité

Veillez lire attentivement cette section avant de commencer. Ce texte traite des mesures de sécurité qu'il convient de prendre pour l'installation d'un produit Sun Microsystems.

Mesures de sécurité

Pour votre sécurité, nous vous recommandons de suivre scrupuleusement les mesures de sécurité ci-dessous lorsque vous installez votre matériel:

- Suivez tous les avertissements et toutes les instructions inscrites sur le matériel.
- Assurez-vous que la tension et la fréquence de votre source d'alimentation correspondent à la tension et à la fréquence indiquées sur l'étiquette de la tension électrique nominale du matériel
- N'introduisez jamais d'objets quels qu'ils soient dans les ouvertures de l'équipement. Vous pourriez vous trouver en présence de hautes tensions dangereuses. Tout objet étranger conducteur risque de produire un court-circuit pouvant présenter un risque d'incendie ou de décharge électrique, ou susceptible d'endommager le matériel.

Symboles

Vous trouverez ci-dessous la signification des différents symboles utilisés:



Attention – Vous risquez d'endommager le matériel ou de vous blesser. Veuillez suivre les instructions.



Attention – Surfaces brûlantes. Evitez tout contact. Les surfaces sont brûlantes. Vous risquez de vous blesser si vous les touchez.



Attention – Tensions dangereuses. Pour réduire les risques de décharge électrique et de danger physique, observez les consignes indiquées.

Selon le type d'interrupteur marche/arrêt dont votre appareil est équipé, l'un des symboles suivants sera utilisé:



Marche – Met le système sous tension alternative.



Arrêt – Met le système hors tension alternative.



Veilleuse – L'interrupteur Marche/Veille est sur la position de veille.

Modification du matériel

N'apportez aucune modification mécanique ou électrique au matériel. Sun Microsystems décline toute responsabilité quant à la non-conformité éventuelle d'un produit Sun modifié.

Positionnement d'un produit Sun



Attention – Evitez d'obstruer ou de recouvrir les orifices de votre produit Sun. N'installez jamais un produit Sun près d'un radiateur ou d'une source de chaleur. Si vous ne respectez pas ces consignes, votre produit Sun risque de surchauffer et son fonctionnement en sera altéré.

Niveau de pression acoustique

Le niveau de pression acoustique du lieu de travail définie par la norme DIN 45 635 Part 1000 doit être au maximum de 70 db(A).

Conformité SELV

Le niveau de sécurité des connexions E/S est conforme aux normes SELV.

Connexion du cordon d'alimentation



Attention – Les produits Sun sont conçus pour fonctionner avec des systèmes d'alimentation équipés d'un conducteur neutre relié à la terre (conducteur neutre pour produits alimentés en CC). Pour réduire les risques de décharge électrique, ne branchez jamais les produits Sun sur une source d'alimentation d'un autre type. Contactez le gérant de votre bâtiment ou un électricien agréé si vous avez le moindre doute quant au type d'alimentation fourni dans votre bâtiment.



Attention – Tous les cordons d'alimentation ne présentent pas les mêmes caractéristiques électriques. Les cordons d'alimentation à usage domestique ne sont pas protégés contre les surtensions et ne sont pas conçus pour être utilisés avec des ordinateurs. N'utilisez jamais de cordon d'alimentation à usage domestique avec les produits Sun.

L'avertissement suivant s'applique uniquement aux systèmes équipés d'un interrupteur Veille:



Attention – L'interrupteur d'alimentation de ce produit fonctionne uniquement comme un dispositif de mise en veille. Le cordon d'alimentation constitue le moyen principal de déconnexion de l'alimentation pour le système. Assurez-vous de le brancher dans une prise d'alimentation mise à la terre près du système et facile d'accès. Ne le branchez pas lorsque l'alimentation électrique ne se trouve pas dans le châssis du système.

L'avertissement suivant s'applique uniquement aux systèmes équipés de plusieurs cordons d'alimentation:



Attention – Pour mettre un système équipé de plusieurs cordons d'alimentation hors tension, il est nécessaire de débrancher tous les cordons d'alimentation.

Mise en garde relative aux batteries



Attention – Les batteries risquent d'exploser en cas de manipulation maladroite ou de remplacement incorrect. Pour les systèmes dont les batteries sont remplaçables, effectuez les remplacements uniquement selon le modèle du fabricant ou un modèle équivalent recommandé par le fabricant, conformément aux instructions fournies dans le manuel de service du système. N'essayez en aucun cas de démonter les batteries, ni de les recharger hors du système. Ne les jetez pas au feu. Mettez-les au rebut selon les instructions du fabricant et conformément à la législation locale en vigueur. Notez que sur les cartes processeur de Sun, une batterie au lithium a été moulée dans l'horloge temps réel. Les batteries ne sont pas des pièces remplaçables par le client.

Couvercle de l'unité

Pour ajouter des cartes, de la mémoire ou des périphériques de stockage internes, vous devez retirer le couvercle de votre système Sun. Remettez le couvercle supérieur en place avant de mettre votre système sous tension.



Attention – Ne mettez jamais des produits Sun sous tension si leur couvercle supérieur n'est pas mis en place. Si vous ne prenez pas ces précautions, vous risquez de vous blesser ou d'endommager le système.

Mise en garde relative au système en rack

La mise en garde suivante s'applique aux racks et aux systèmes montés en rack.



Attention – Pour des raisons de sécurité, le matériel doit toujours être chargé du bas vers le haut. En d'autres termes, vous devez installer, en premier, le matériel qui doit se trouver dans la partie la plus inférieure du rack, puis installer le matériel sur le niveau suivant, etc.



Attention – Afin d'éviter que le rack ne penche pendant l'installation du matériel, tirez la barre anti-basculement du rack.



Attention – Pour éviter des températures de fonctionnement extrêmes dans le rack, assurez-vous que la température maximale ne dépasse pas la fourchette de températures ambiantes du produit déterminée par le fabricant.



Attention – Afin d'empêcher des températures de fonctionnement extrêmes provoquées par une aération insuffisante, assurez-vous de fournir une aération appropriée pour un fonctionnement du matériel en toute sécurité

Avis de conformité des appareils laser

Les produits Sun qui font appel aux technologies lasers sont conformes aux normes de la classe 1 en la matière.

Class 1 Laser Product
Luokan 1 Laserlaite
Klasse 1 Laser Apparat
Laser Klasse 1

Périphériques CD et DVD

L'avertissement suivant s'applique aux périphériques CD, DVD et autres périphériques optiques:



Attention – L'utilisation de contrôles et de réglages ou l'application de procédures autres que ceux spécifiés dans le présent document peuvent entraîner une exposition à des radiations dangereuses.

Einhaltung sicherheitsbehördlicher Vorschriften

Lesen Sie vor dem Ausführen von Arbeiten diesen Abschnitt. Im folgenden Text werden Sicherheitsvorkehrungen beschrieben, die Sie bei der Installation eines Sun Microsystems-Produkts beachten müssen.

Sicherheitsvorkehrungen

Treffen Sie zu Ihrem eigenen Schutz bei der Installation des Geräts die folgenden Sicherheitsvorkehrungen:

- Beachten Sie alle auf den Geräten angebrachten Warnhinweise und Anweisungen.
- Stellen Sie sicher, dass Spannung und Frequenz der Stromversorgung den Nennleistungen auf dem am Gerät angebrachten Etikett entsprechen.
- Führen Sie niemals Fremdobjekte in die Öffnungen am Gerät ein. Es können gefährliche Spannungen anliegen. Leitfähige Fremdobjekte können einen Kurzschluss verursachen, der einen Brand, Stromschlag oder Geräteschaden herbeiführen kann.

Symbole

Die Symbole in diesem Handbuch haben folgende Bedeutung:



Achtung – Gefahr von Verletzung und Geräteschaden. Befolgen Sie die Anweisungen.



Achtung – Heiße Oberfläche. Nicht berühren, da Verletzungsgefahr durch heiße Oberfläche besteht.



Achtung – Gefährliche Spannungen. Befolgen Sie die Anweisungen, um Stromschläge und Verletzungen zu vermeiden.

Je nach Netzschaltertyp an Ihrem Gerät kann eines der folgenden Symbole verwendet werden:



Ein – Versorgt das System mit Wechselstrom.



Aus – Unterbricht die Wechselstromzufuhr zum Gerät.



Wartezustand – Der Ein-/Standby-Netzschalter befindet sich in der Standby-Position.

Modifikationen des Geräts

Nehmen Sie keine elektrischen oder mechanischen Gerätemodifikationen vor. Sun Microsystems ist für die Einhaltung der Sicherheitsvorschriften von modifizierten Sun-Produkten nicht haftbar.

Aufstellung von Sun-Geräten



Achtung – Geräteöffnungen Ihres Sun-Produkts dürfen nicht blockiert oder abgedeckt werden. Sun-Geräte sollten niemals in der Nähe von Heizkörpern oder Heißluftklappen aufgestellt werden. Die Nichtbeachtung dieser Richtlinien kann Überhitzung verursachen und die Zuverlässigkeit Ihres Sun-Geräts beeinträchtigen.

Lautstärke

Gemäß den in DIN 45 635 Teil 1000 definierten Vorschriften beträgt die arbeitsplatzbedingte Lautstärke dieses Produkts weniger als 70 dB(A).

SELV-Konformität

Der Sicherheitsstatus der E/A-Verbindungen entspricht den SELV-Anforderungen.

Anschluss des Netzkabels



Achtung – Sun-Geräte sind für Stromversorgungssysteme mit einem geerdeten neutralen Leiter (geerdeter Rückleiter bei gleichstrombetriebenen Geräten) ausgelegt. Um die Gefahr von Stromschlägen zu vermeiden, schließen Sie das Gerät niemals an andere Stromversorgungssysteme an. Wenden Sie sich an den zuständigen Gebäudeverwalter oder an einen qualifizierten Elektriker, wenn Sie nicht sicher wissen, an welche Art von Stromversorgungssystem Ihr Gebäude angeschlossen ist.



Achtung – Nicht alle Netzkabel verfügen über die gleichen Nennwerte. Herkömmliche, im Haushalt verwendete Verlängerungskabel besitzen keinen Überlastschutz und sind daher für Computersysteme nicht geeignet. Verwenden Sie bei Ihrem Sun-Produkt keine Haushalts-Verlängerungskabel.

Die folgende Warnung gilt nur für Geräte mit Standby-Netzschalter:



Achtung – Beim Netzschalter dieses Geräts handelt es sich nur um einen Ein/Standby-Schalter. Zum völligen Abtrennen des Systems von der Stromversorgung dient hauptsächlich das Netzkabel. Stellen Sie sicher, dass das Netzkabel an eine frei zugängliche geerdete Steckdose in der Nähe des Systems angeschlossen ist. Schließen Sie das Stromkabel nicht an, wenn die Stromversorgung vom Systemchassis entfernt wurde.

Die folgende Warnung gilt nur für Geräte mit mehreren Netzkabeln:



Achtung – Bei Produkten mit mehreren Netzkabeln müssen alle Netzkabel abgetrennt werden, um das System völlig von der Stromversorgung zu trennen.

Warnung bezüglich Batterien



Achtung – Bei unsachgemäßer Handhabung oder nicht fachgerechtem Austausch der Batterien besteht Explosionsgefahr. Verwenden Sie bei Systemen mit austauschbaren Batterien ausschließlich Ersatzbatterien desselben Typs und Herstellers bzw. einen entsprechenden, vom Hersteller gemäß den Anweisungen im Service-Handbuch des Produkts empfohlenen Batterietyp. Versuchen Sie nicht, die Batterien auszubauen oder außerhalb des Systems wiederaufzuladen. Werfen Sie die Batterien nicht ins Feuer. Entsorgen Sie die Batterien entsprechend den Anweisungen des Herstellers und den vor Ort geltenden Vorschriften. CPU-Karten von Sun verfügen über eine Echtzeituhr mit integrierter Lithiumbatterie. Diese Batterie darf nur von einem qualifizierten Servicetechniker ausgetauscht werden.

Gehäuseabdeckung

Sie müssen die Abdeckung Ihres Sun-Computersystems entfernen, um Karten, Speicher oder interne Speichergeräte hinzuzufügen. Bringen Sie vor dem Einschalten des Systems die Gehäuseabdeckung wieder an.



Achtung – Nehmen Sie Sun-Geräte nicht ohne Abdeckung in Betrieb. Die Nichtbeachtung dieses Warnhinweises kann Verletzungen oder Geräteschaden zur Folge haben.

Warnungen bezüglich in Racks eingebauter Systeme

Die folgenden Warnungen gelten für Racks und in Racks eingebaute Systeme:



Achtung – Aus Sicherheitsgründen sollten sämtliche Geräte von unten nach oben in Racks eingebaut werden. Installieren Sie also zuerst die Geräte, die an der untersten Position im Rack eingebaut werden, gefolgt von den Systemen, die an nächsthöherer Stelle eingebaut werden, usw.



Achtung – Verwenden Sie beim Einbau den Kippschutz am Rack, um ein Umkippen zu vermeiden.



Achtung – Um extreme Betriebstemperaturen im Rack zu vermeiden, stellen Sie sicher, dass die Maximaltemperatur die Nennleistung der Umgebungstemperatur für das Produkt nicht überschreitet



Achtung – Um extreme Betriebstemperaturen durch verringerte Luftzirkulation zu vermeiden, sollte die für den sicheren Betrieb des Geräts erforderliche Luftzirkulation eingesetzt werden.

Hinweis zur Laser-Konformität

Sun-Produkte, die die Laser-Technologie verwenden, entsprechen den Laser-Anforderungen der Klasse 1.

Class 1 Laser Product
Luokan 1 Laserlaite
Klasse 1 Laser Apparat
Laser Klasse 1

CD- und DVD-Geräte

Die folgende Warnung gilt für CD-, DVD- und andere optische Geräte:



Achtung – Die hier nicht aufgeführte Verwendung von Steuerelementen, Anpassungen oder Ausführung von Vorgängen kann eine gefährliche Strahlenbelastung verursachen.

Normativas de seguridad

Lea esta sección antes de realizar cualquier operación. En ella se explican las medidas de seguridad que debe tomar al instalar un producto de Sun Microsystems.

Medidas de seguridad

Para su protección, tome las medidas de seguridad siguientes durante la instalación del equipo:

- Siga todos los avisos e instrucciones indicados en el equipo.
- Asegúrese de que el voltaje y frecuencia de la fuente de alimentación coincidan con el voltaje y frecuencia indicados en la etiqueta de clasificación eléctrica del equipo.
- No introduzca objetos de ningún tipo por las rejillas del equipo, ya que puede quedar expuesto a voltajes peligrosos. Los objetos conductores extraños pueden producir cortocircuitos y, en consecuencia, incendios, descargas eléctricas o daños en el equipo.

Símbolos

En este documento aparecen los siguientes símbolos:



Precaución – Existe el riesgo de que se produzcan lesiones personales y daños en el equipo. Siga las instrucciones.



Precaución – Superficie caliente. Evite todo contacto. Las superficies están calientes y pueden causar lesiones personales si se tocan.



Precaución – Voltaje peligroso. Para reducir el riesgo de descargas eléctricas y lesiones personales, siga las instrucciones.

En función del tipo de interruptor de alimentación del que disponga el dispositivo, se utilizará uno de los símbolos siguientes:



Encendido – Suministra alimentación de CA al sistema.



Apagado – Corta la alimentación de CA del sistema.



Espera – El interruptor de encendido/espera está en la posición de espera.

Modificaciones en el equipo

No realice modificaciones de tipo mecánico ni eléctrico en el equipo. Sun Microsystems no se hace responsable del cumplimiento de normativas en caso de que un producto Sun se haya modificado.

Colocación de un producto Sun



Precaución – No obstruya ni tape las rejillas del producto Sun. Nunca coloque un producto Sun cerca de radiadores ni fuentes de calor. Si no sigue estas indicaciones, el producto Sun podría sobrecalentarse y la fiabilidad de su funcionamiento se vería afectada.

Nivel de ruido

De conformidad con los requisitos establecidos en el apartado 1000 de la norma DIN 45635, el nivel de ruido en el lugar de trabajo producido por este producto es menor de 70 db(A).

Cumplimiento de la normativa para instalaciones SELV

Las condiciones de seguridad de las conexiones de entrada y salida cumplen los requisitos para instalaciones SELV (del inglés *Safe Extra Low Voltage*, voltaje bajo y seguro).

Conexión del cable de alimentación



Precaución – Los productos Sun se han diseñado para funcionar con sistemas de alimentación que cuenten con un conductor neutro a tierra (con conexión a tierra de regreso para los productos con alimentación de CC). Para reducir el riesgo de descargas eléctricas, no conecte ningún producto Sun a otro tipo de sistema de alimentación. Póngase en contacto con el encargado de las instalaciones de su empresa o con un electricista cualificado en caso de que no esté seguro del tipo de alimentación del que se dispone en el edificio.



Precaución – No todos los cables de alimentación tienen la misma clasificación eléctrica. Los alargadores de uso doméstico no cuentan con protección frente a sobrecargas y no están diseñados para su utilización con sistemas informáticos. No utilice alargadores de uso doméstico con el producto Sun.

La siguiente medida solamente se aplica a aquellos dispositivos que dispongan de un interruptor de alimentación de espera:



Precaución – El interruptor de alimentación de este producto funciona solamente como un dispositivo de espera. El cable de alimentación hace las veces de dispositivo de desconexión principal del sistema. Asegúrese de que conecta el cable de alimentación a una toma de tierra situada cerca del sistema y de fácil acceso. No conecte el cable de alimentación si la unidad de alimentación no se encuentra en el bastidor del sistema.

La siguiente medida solamente se aplica a aquellos dispositivos que dispongan de varios cables de alimentación:



Precaución – En los productos que cuentan con varios cables de alimentación, debe desconectar todos los cables de alimentación para cortar por completo la alimentación eléctrica del sistema.

Advertencia sobre las baterías



Precaución – Si las baterías no se manipulan o reemplazan correctamente, se corre el riesgo de que estallen. En los sistemas que cuentan con baterías reemplazables, reemplácelas sólo con baterías del mismo fabricante y el mismo tipo, o un tipo equivalente recomendado por el fabricante, de acuerdo con las instrucciones descritas en el manual de servicio del producto. No desmonte las baterías ni intente recargarlas fuera del sistema. No intente deshacerse de las baterías echándolas al fuego. Deshágase de las baterías correctamente de acuerdo con las instrucciones del fabricante y las normas locales. Tenga en cuenta que en las placas CPU de Sun, hay una batería de litio incorporada en el reloj en tiempo real. Los usuarios no deben reemplazar este tipo de baterías.

Cubierta de la unidad del sistema

Debe extraer la cubierta de la unidad del sistema informático Sun para instalar tarjetas, memoria o dispositivos de almacenamiento internos. Vuelva a colocar la cubierta antes de encender el sistema informático.



Precaución – No ponga en funcionamiento los productos Sun que no tengan colocada la cubierta. De lo contrario, puede sufrir lesiones personales y ocasionar daños en el sistema.

Advertencia sobre el sistema en bastidor

Las advertencias siguientes se aplican a los sistemas montados en bastidor y a los propios bastidores.



Precaución – Por seguridad, siempre deben montarse los equipos de abajo arriba. A saber, primero debe instalarse el equipo que se situará en el bastidor inferior; a continuación, el que se situará en el siguiente nivel, etc.



Precaución – Para evitar que el bastidor se vuelque durante la instalación del equipo, debe extenderse la barra antivoltado del bastidor.



Precaución – Para evitar que se alcance una temperatura de funcionamiento extrema en el bastidor, asegúrese de que la temperatura máxima no sea superior a la temperatura ambiente establecida como adecuada para el producto.



Precaución – Para evitar que se alcance una temperatura de funcionamiento extrema debido a una circulación de aire reducida, debe considerarse la magnitud de la circulación de aire requerida para que el equipo funcione de forma segura.

Aviso de cumplimiento de la normativa para la utilización de láser

Los productos Sun que utilizan tecnología láser cumplen los requisitos establecidos para los productos láser de clase 1.

Class 1 Laser Product
Luokan 1 Laserlaite
Klasse 1 Laser Apparat
Laser Klasse 1

Dispositivos de CD y DVD

La siguiente medida se aplica a los dispositivos de CD y DVD, así como a otros dispositivos ópticos:



Precaución – La utilización de controles, ajustes o procedimientos distintos a los aquí especificados puede dar lugar a niveles de radiación peligrosos.

Nordic Lithium Battery Cautions

Norge



Advarsel – Litiumbatteri — Eksplosjonsfare. Ved utskifting benyttes kun batteri som anbefalt av apparatfabrikanten. Brukt batteri returneres apparatleverandøren.

Sverige



Varning – Explosionsfara vid felaktigt batteribyte. Använd samma batterityp eller en ekvivalent typ som rekommenderas av apparattillverkaren. Kassera använt batteri enligt fabrikantens instruktion.

Danmark



Advarsel! – Litiumbatteri — Eksplosionsfare ved fejlagtig håndtering. Udskiftning må kun ske med batteri af samme fabrikat og type. Levér det brugte batteri tilbage til leverandøren.

Suomi



Varoitus – Paristo voi räjähtää, jos se on virheellisesti asennettu. Vaihda paristo ainoastaan laitevalmistajan suosittelemaan tyyppiin. Hävitä käytetty paristo valmistajan ohjeiden mukaisesti.

Preface

The *Sun Fire™ 6800/4810/4800/3800 Systems Installation Guide* provides installation instructions for Sun Fire 6800, Sun Fire 4810, Sun Fire 4800, and Sun Fire 3800 systems. These instructions are for an experienced systems or field engineer with networking knowledge.

Typographic Conventions

Typeface or Symbol	Meaning	Examples
AaBbCc123	The names of commands, files, and directories; on-screen computer output.	Edit your <code>.login</code> file. Use <code>ls -a</code> to list all files.
AaBbCc123	What you type, when contrasted with on-screen computer output.	% su Password:
<i>AaBbCc123</i>	Book titles, new words or terms, words to be emphasized. Command-line variable; replace with a real name or value.	Read Chapter 6 in the <i>User's Guide</i> . These are called <i>class</i> options. You <i>must</i> be superuser to do this. To delete a file, type <code>rm filename</code> .

Related Documentation

Application	Title
	<i>Sun Fire 6800/4810/4800/3800 System Getting Started</i>
	<i>Sun Fire 6800/4810/4800/3800 Systems Overview Manual</i>
Hardware	<i>Sun Fire Cabinet Installation and Reference Manual</i>
	<i>Sun Fire 4810/4800/3800 Systems Cabinet Mounting Guide</i>
	<i>Sun Fire 6800/4810/4800/3800 Systems Service Manual</i>
Software	<i>Sun Fire Midrange Systems Controller Command Reference Manual</i>
	<i>Sun Fire Midrange Systems Platform Administration Manual</i>

Accessing Sun Documentation

You can view, print, or purchase a broad selection of Sun documentation, including localized versions, at:

<http://www.sun.com/documentation>

Sun Welcomes Your Comments

Sun is interested in improving its documentation and welcomes your comments and suggestions. You can email your comments to Sun at:

<http://www.sun.com/hwdocs/feedback>

Please include the title and part number (817-2353-12) of your document with your feedback.

Contacting Sun Technical Support

If you have technical questions about this product that are not answered in this document, go to:

<http://www.sun.com/service/contacting>

Cautions and Notes



Caution – This equipment contains lethal voltage. Accidental contact with centerplane, card cage, and drive areas can result in serious injury or death.



Caution – Improper handling by unqualified personnel can cause serious damage to this equipment. Unqualified personnel who tamper with this equipment may be held liable for any resultant damage to the equipment.

Individuals who remove any outer panels or open covers to access this equipment must observe all safety precautions and ensure compliance with skill level requirements, certification, and all applicable local and national laws.

Procedures contained in this document must be performed by qualified service-trained maintenance providers.

Note – Before you begin, carefully read each of the procedures in this manual. If you have not performed similar operations on comparable equipment, *do not attempt* to perform these procedures.

Preparing for Installation

This chapter describes how to prepare your site for the Sun Fire 6800, Sun Fire 4810, Sun Fire 4800, and Sun Fire 3800 systems.

Note – For information about physical specifications, electrical specifications, and environmental requirements, refer to the *Sun Fire 6800/4810/4800/3800 Systems Site Planning Guide*.

- Verifying the Electrical Circuits—[page 1-1](#)
- Verifying the Air Conditioning—[page 1-2](#)
- Verifying the Floor Area—[page 1-3](#)

1.1 Verifying the Electrical Circuits

Because large AC currents may be needed, each of the following items requires a separate power circuit:

- Each AC power cord for the system (or each RTS power cable for Sun Fire 6800 systems and systems mounted in a Sun Fire cabinet)
- External peripherals
- Monitor used for diagnostics

The Sun Fire 6800 system requires four dedicated 200–240 VAC, 30A circuit breakers.



Caution – Do not attach other electrical equipment to the AC circuit for the system; system reliability can be affected.

Note – If the appropriate electrical receptacle is not available in your country, the connector can be removed from the cable. The cable can then be permanently connected to a dedicated branch circuit by a qualified electrician. Check local electrical codes for proper installation requirements.



Caution – Strictly observe the following instructions to reduce the risk of electric shock.

Sun Fire systems require an electrical circuit that is grounded to earth. The UL1950, CSA950, and EN60950 specify:

An insulated earthing conductor that is identical in size, insulation material, and thickness to the earthed and unearthed branch-circuit supply conductors, except that it is green with or without one or more yellow stripes, is to be installed as part of the branch circuit that supplies the unit or system. The earthing conductor described is to be connected to earth at the service equipment or, if supplied by a separately derived system, at the supply transformer or motor-generator set.

The attachment-plug receptacles in the vicinity of the unit or system are all to be of an earthing type, and the earthing conductors serving these receptacles are to be connected to earth at the service equipment.¹

The power cord provides a ground path that will protect the drives and boards in the cabinet from static electricity damage.



Caution – Do not make mechanical or electrical modifications to the system. Sun Microsystems® is not responsible for the regulatory compliance if the system is modified.

1.2 Verifying the Air Conditioning

For the most reliable system operation:

- The room must have sufficient air-conditioning capacity to support the cooling needs of the entire system.
- The air-conditioning system must have controls that prevent excessive temperature changes. Refer to the Sun Fire *6800/4810/4800/3800 Systems Site Planning Guide* for exact cooling requirements.

1. Information Technology Equipment — UL 1950, copyright 1989, 1991 by Underwriters Laboratories, Inc.

1.3 Verifying the Floor Area

- Sun Fire 6800 systems and rackmounted systems require approximately 48 inches (120 centimeters) of space in front and 36 inches (90 centimeters) in back (FIGURE 1-1) for access by service personnel.
- System and expansion cabinets can be placed next to each other since there are no side clearance requirements during operation.
- Keep power and interface cables out of the way. Cables can be routed inside walls, floors, ceilings, or in protective channels. Interface cables must be routed away from motors and other sources of electric/magnetic or radio frequency interference.
- The Sun Fire 6800 system cabinet has openings at the top rear corners and at the bottom of the cabinet for cable routing.
- If the system is mounted in a Sun Fire cabinet then each RTS power cable must have a dedicated AC breaker panel.
- If the Sun Fire 4810, Sun Fire 4800, or Sun Fire 3800 system is not mounted in a Sun Fire cabinet each AC power cord for systems must have a dedicated AC breaker panel.

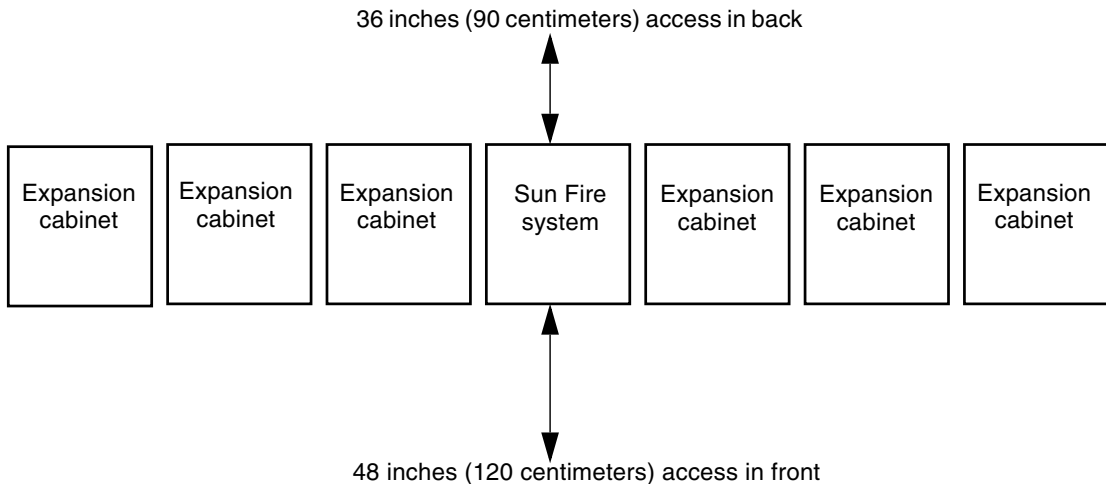

FIGURE 1-1 Sun Fire System Access Areas—Top View

Installing the Sun Fire 6800 System

This chapter contains procedures for moving the Sun Fire 6800 system, connecting the cables, powering the system and installing additional hardware.

- Tools—[page 2-1](#)
- Unpacking the Sun Fire 6800 System—[page 2-2](#)
- Moving and Securing the Sun Fire 6800 System—[page 2-3](#)
- Connecting Power Cables to the Sun Fire 6800 System—[page 2-8](#)
- Connecting the I/O Assemblies—[page 2-11](#)
- Connecting the Administrative Console—[page 2-12](#)
- Powering On the Sun Fire 6800 System—[page 2-14](#)
- Powering Off the Sun Fire 6800 System—[page 2-16](#)
- Installing Additional Hardware—[page 2-16](#)
- Installing Peripheral Devices—[page 2-17](#)

Note – When you receive your system, leave it in the shipping crate at its final destination *for 24 hours* to prevent thermal shock and condensation.

2.1 Tools

- Leveling wrench (combination 1/2-inch and 9/16-inch wrench located in the upper rear of the cabinet)
- System keys (one in the front door and the second in the shipping kit)

2.2 Unpacking the Sun Fire 6800 System

1. Remove the bands and cap from the shipping carton (FIGURE 2-1).

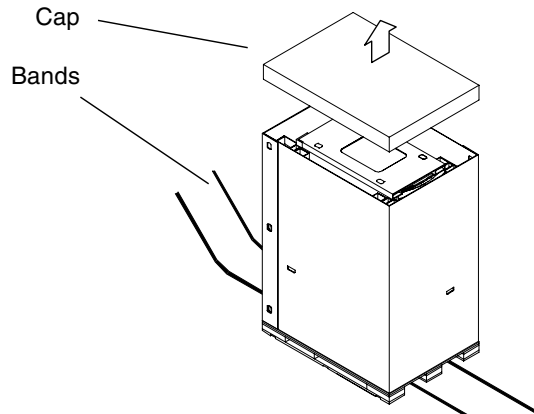

FIGURE 2-1 Unpacking the Sun Fire 6800 System—Step 1

2. Remove the plastic clips that keep the two main sections of the shipping carton together (FIGURE 2-2).

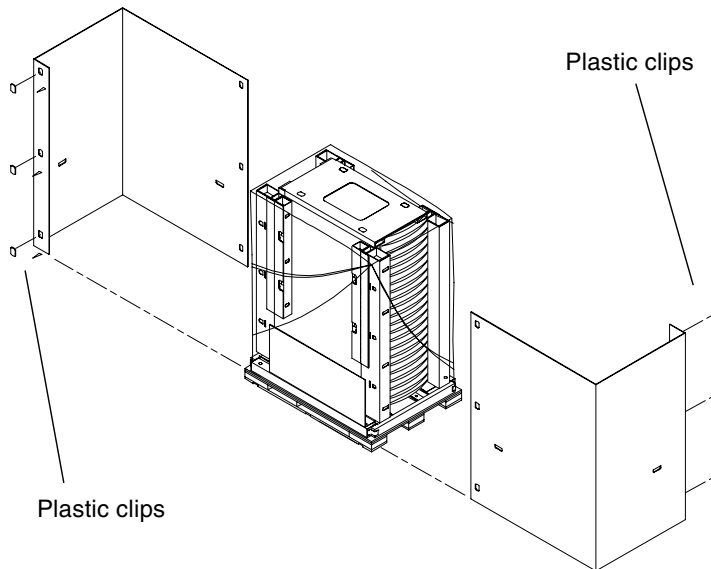

FIGURE 2-2 Unpacking the Sun Fire 6800 System—Step 2

3. Remove the plastic bag that covers the system and remove the ramps.
4. Unlock the rear door of the system with the system keys and remove the leveling wrench that is attached to the upper-rear of the system cabinet frame.
System keys should be attached to either the front or rear door. The wrench is attached by a reusable plastic strap. Do not cut the strap.
 - a. Press the plastic tab to unlock the strap.
 - b. Loosen the strap to remove the wrench.

2.3 Moving and Securing the Sun Fire 6800 System

1. Remove the front wheel stop.
2. Use the leveling wrench to remove the front brackets. Save the brackets for Step 11 (FIGURE 2-3).

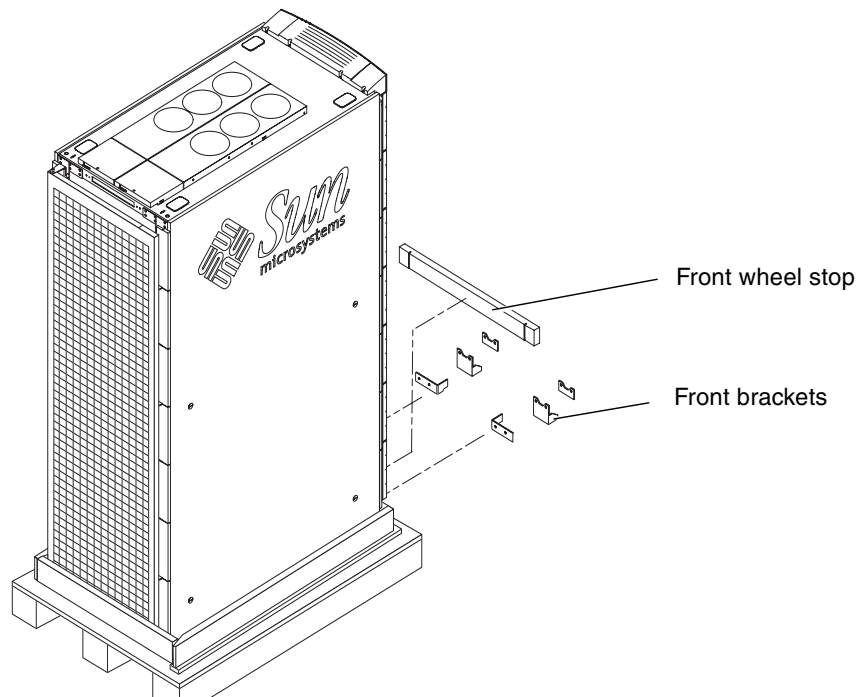

FIGURE 2-3 Front Brackets and Front Wheel Stop

3. Reinstall the front wheel stop.

The front wheel stop prevents the system from inadvertently rolling off the front of the shipping pallet.

4. Remove the rear wheel stop (FIGURE 2-4).

5. Position the ramps so the metal tab connects to the holes on the rear of the shipping pallet.

6. Use the leveling wrench to remove the rear brackets. Save the brackets for Step 11.

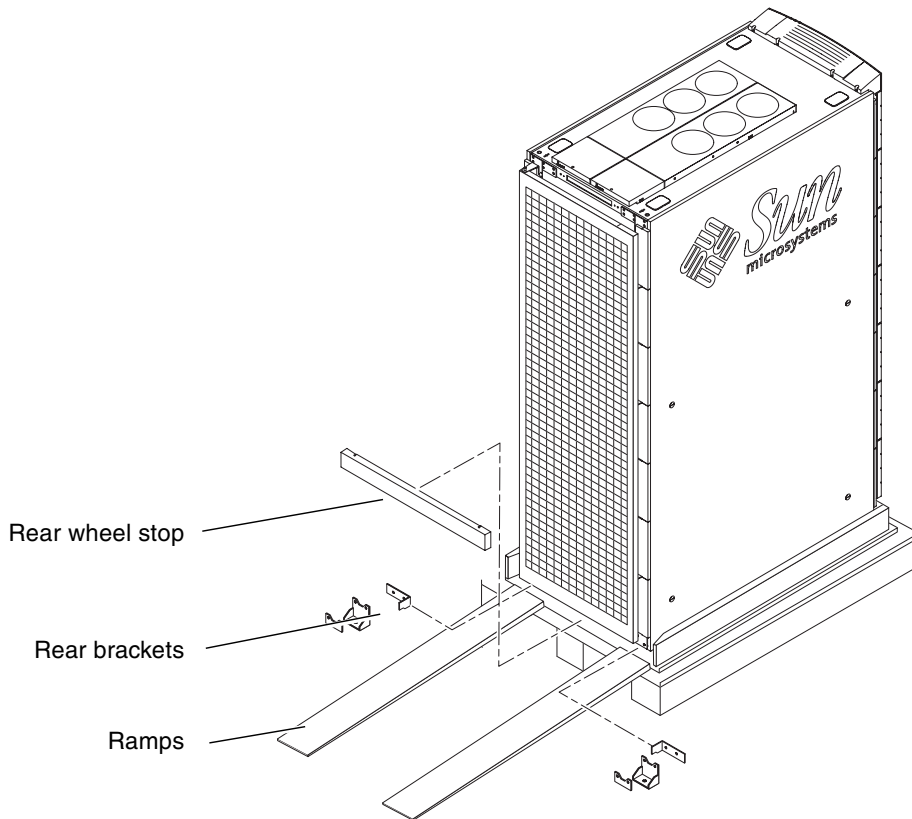

FIGURE 2-4 Removing the Rear Brackets and Rear Wheel Stop and Positioning Ramps

7. Use the leveling wrench to raise the leveling pads as high as they will go, so the system is free to move.

8. Secure the leveling wrench back in the system with the plastic strap, and close the front and rear doors.



Caution – A Sun Fire 6800 system is very heavy. Three or more people are needed to move the system safely. Two people must control the movement of the system from the sides while the third pushes slowly from the front. To prevent the system from tipping over, push or pull only along the middle of the system.

9. Move the system carefully down the ramps (FIGURE 2-5).

10. Move the system to the operating location.

Always push from the front of the system to keep from tipping the system over.

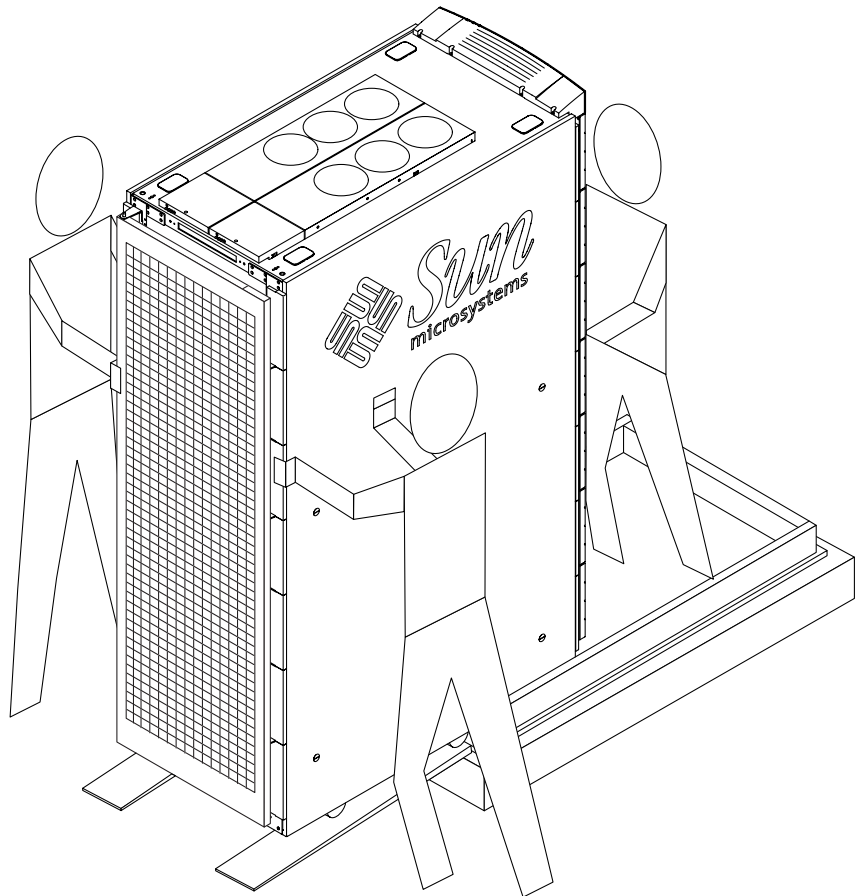

FIGURE 2-5 Moving the Sun Fire 6800 System Off the Shipping Pallet

2.3.1 Adjusting the Leveling Pads

If the system will not be bracketed to the floor of the operating location you must lower the leveling pads to prevent movement.

1. Remove the leveling wrench from inside the system.
2. Use the leveling wrench to lower the leveling pads at the four corners of the system so the system cannot move.
3. Secure the leveling wrench inside the system with the plastic strap.

2.3.2 Securing the Cabinet to the Floor

1. Place the NEBS Zone 4 earthquake bracket between the outer kick-panel bracket and the inner kick-panel bracket and secure the assembly to the cabinet using the existing bolts.

Note – It may be necessary to adjust the cabinet leveling pads to align the NEBS Zone 4 earthquake bracket.

2. Repeat **Step 1** for the remaining kick-panel brackets.



Caution – Before you begin drilling examine site blueprints to ensure that no pipes or wires run beneath operating location.

3. Secure all four bracket assemblies to the floor (FIGURE 2-6).

Use a vacuum to prevent air contamination in the computer room while securing the bracket assemblies.

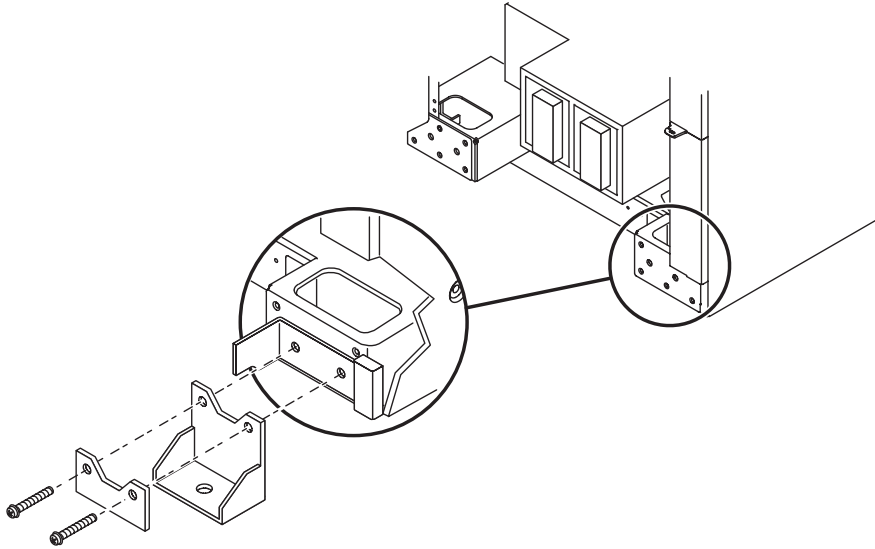

FIGURE 2-6 Bracketing the Sun Fire 6800 System to the floor

Note – Because each operating location is unique, the bolts that secure the brackets to the floor must be supplied by personnel at the site.

2.3.3 Shipping and Storing the System

Save the original shipping container and packing materials in case you need to store or ship your system.

If you cannot store the shipping materials, recycle or dispose of the materials properly. Consult your local recycling authority for information.

2.4 Connecting Power Cables to the Sun Fire 6800 System

1. Turn off each redundant transfer switch (RTS) on both the front and rear of the system (FIGURE 2-7).

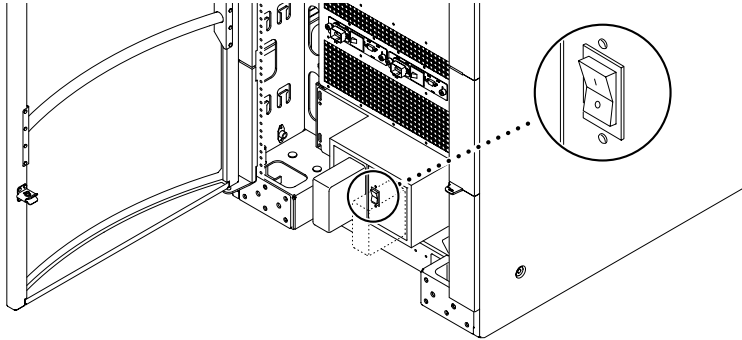

FIGURE 2-7 RTS AC Power Switch on the Sun Fire 6800 System

2. Remove the power cables from the shipping carton.
3. Remove the socket covers on each RTS module.
4. Release the catches and remove the kick-panel.
The kick-panel snaps off.
5. Release the catches and extend the anti-tilt bar at the front of the system.

6. Determine which power cables and RTS modules to use.



Caution – Two totally independent AC power sources are needed for input power redundancy. The AC power sources must be derived from independent power company utility feeds and Sun recommends that each be backed up with an on-line UPS. The power sources are not independent if they are only distinguished by having separate circuit breakers. One RTS hooked to an AC power source and the second RTS hooked to a UPS that is connected to the same AC power source is not supported because when the UPS is by-passed for maintenance both RTSs will be hooked up to the same source. If both RTSs are hooked to one utility feed then both lines must be backed up with on-line UPSs to ensure input power redundancy.

- In configurations with two independent AC power sources there will be four cables to connect, two on the front, and two on the rear of the system (FIGURE 2-8).

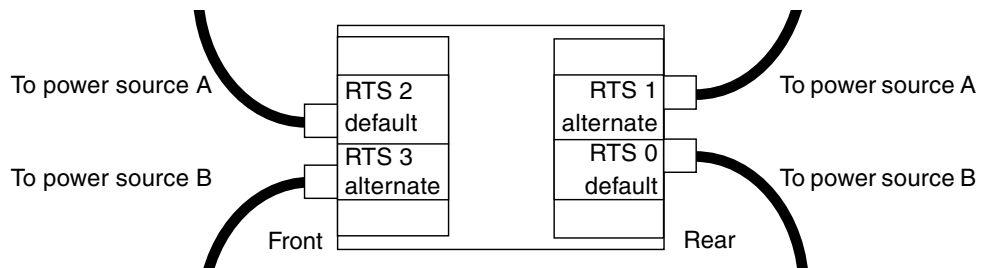

FIGURE 2-8 Two Independent AC Power Sources

- In configurations with one AC power sources there will be two cables to connect, one on the front (on the left), and one on the rear of the system (on the left) (FIGURE 2-9). Connecting the alternate RTS units to outlets that use the same power source as the default RTS units is not supported and will adversely affect reliability.

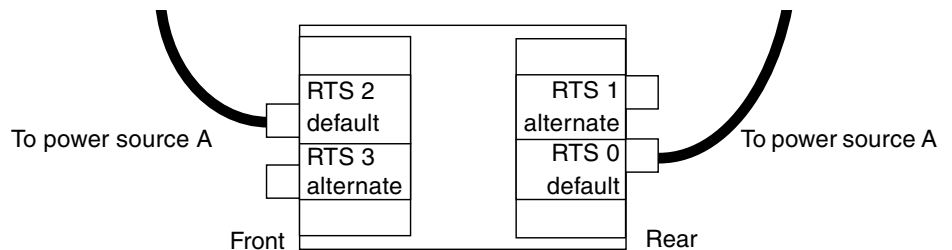

FIGURE 2-9 One AC Power Source

7. Connect the power cable to the RTS module and lock the connector with the lock lever (FIGURE 2-10).

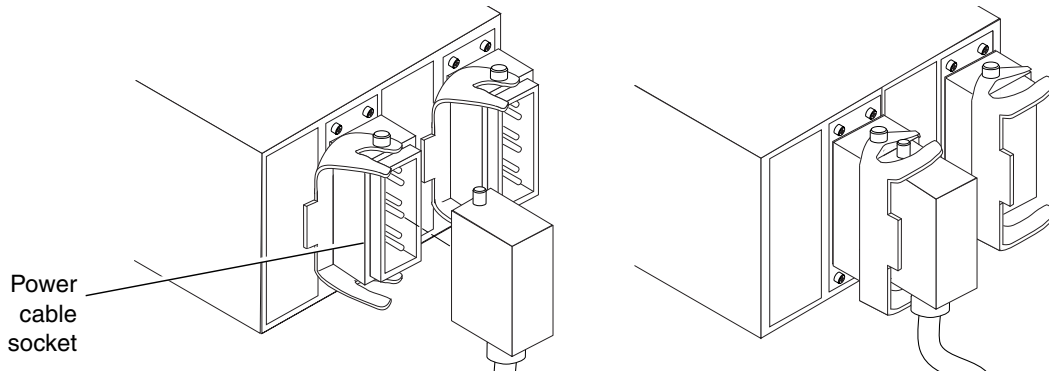

FIGURE 2-10 Connecting Power Cables to the RTS Module

8. Route the power cables from the front of the cabinet beneath or through the system.

Note – If the power source is overhead, do not route the cables beneath the cabinet. Instead turn the cables 180° degrees and route them back into the cabinet through the small holes in the bottom of the cabinet (to the left and right of the RTU assembly). Remove the plastic pop out covers on the top of the cabinet and route the power cables through the top of the cabinet.

9. Push the kick-panel and anti-tilt bar back into place.

The retainers on both parts will retract and snap into place.

10. Connect the other end of each power cable to the dedicated outlet.



Caution – Each outlet must be a 200–240 VAC, 30A circuit solely for use by that power cable. The electrical receptacles must be grounded, and the grounding conductors serving these receptacles must be connected to the earth ground at the service equipment.

2.5 Connecting the I/O Assemblies

The I/O assemblies provide network interface and peripheral access for the domains.

Note – Domains can not share I/O assemblies. If configuring a system with two or more domains make sure that each I/O assembly includes its own network interface card and peripherals.

1. **Connect one end of each I/O cable to the appropriate card in the I/O assembly** ([FIGURE 2-11](#)).
2. **Connect the other end to the hub, workstation or peripheral.**
3. **Attach the cables to the cabinet with plastic ties to keep them out of the way.**

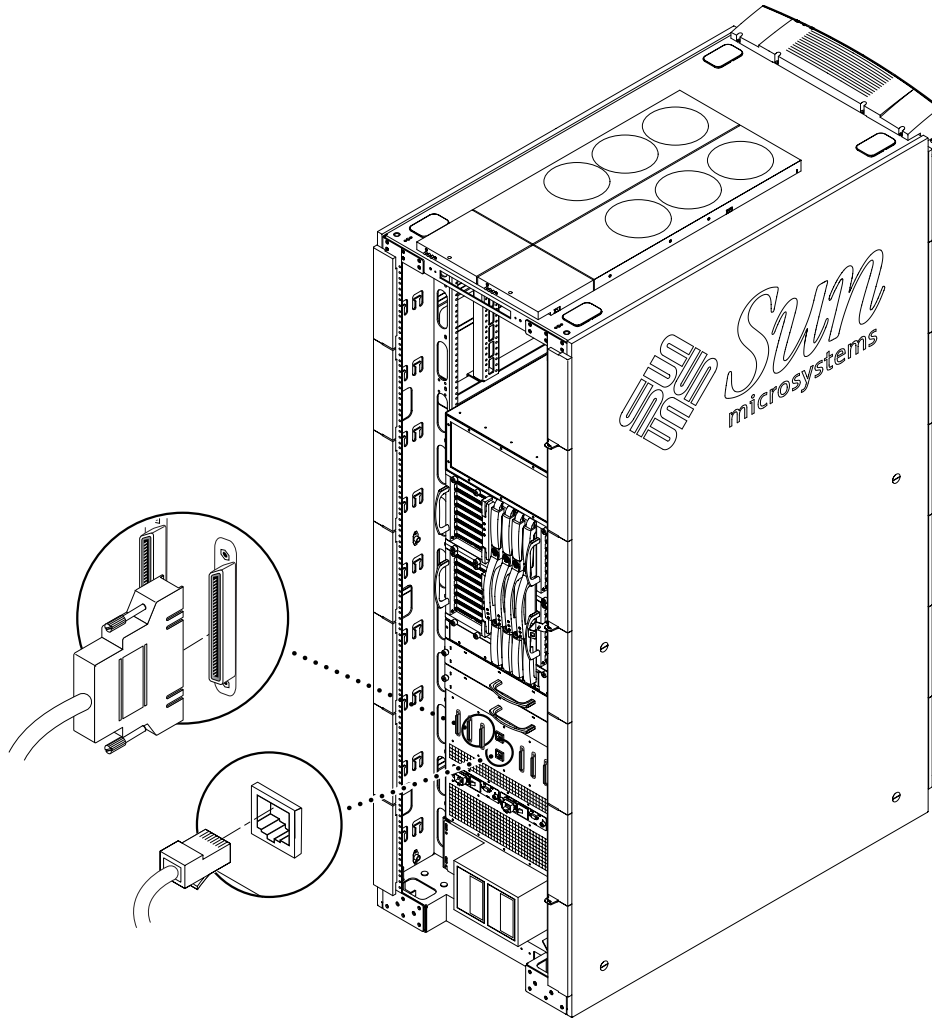

FIGURE 2-11 Primary TTYa Serial Port and Primary Ethernet Connections on the Patch Panel

2.6 Connecting the Administrative Console

The administrative console is used to access the primary System Controller board (SSC0) through the patch panel. It is used to set up the system and control the system controller software. The administrative console can be any external input device (such as a laptop computer or a workstation) connected to the patch panel.

2.6.1 Connecting the ASCII terminal

The initial system setup requires an ASCII terminal connected to the primary TTYa serial port on the patch panel using a null modem cable or through a network terminal server (NTS) (FIGURE 2-12).

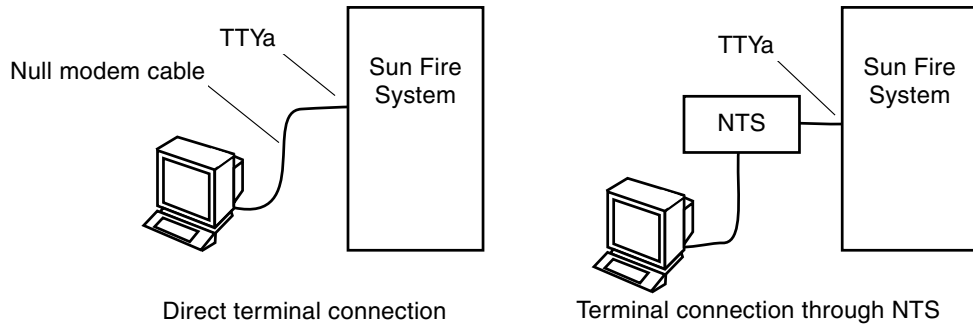

FIGURE 2-12 Serial Cable Connections

1. Connect one end of the serial cable (TTYa or Null modem) to the primary serial port on the patch panel (FIGURE 2-11).
2. Connect the other end of the serial cable to the chosen ASCII terminal or NTS server (FIGURE 2-12).
3. Set up the chosen ASCII terminal as an administrative console.

Refer to the *Sun Fire Midrange Systems Platform Administration Manual* for instructions on setting up the ASCII terminal as an administrative console.

2.6.2 Connecting the Administrative Console

Once the system is set up, most system administration tasks can be performed through the network via the primary RJ-45 Ethernet port on the patch panel using a Category-5 Ethernet cable.

1. Connect one end of the shielded Category-5 Ethernet cable to the primary RJ-45 Ethernet port on the patch panel (FIGURE 2-11).
2. Connect the other end of the shielded Category-5 Ethernet cable to the chosen administrative console (local hub, router, or switch).
3. Set up the chosen administrative console.

Refer to the *Sun Fire Midrange Systems Platform Administration Manual* for instructions on setting up the administrative console.

2.7 Powering On the Sun Fire 6800 System

Note – It is advisable to connect an administration console to the system during installation. Refer to the *Sun Fire Midrange Systems Platform Administration Manual* for terminal settings and connections.

1. **Begin with a safety inspection of the system.**
 - a. **Verify that the system AC power cables are connected to a wall socket and the power supplies.**
 - b. **Turn the AC power switches off on the RTUs at the front and rear of the system (FIGURE 2-13).**



Caution – Do not disconnect the AC power cable from the wall connection when you work on or in the Sun Fire 6800 system. This connection provides a ground path that prevents damage from electrostatic discharge (ESD).

2. **Power on the wall circuit breakers.**
3. **Power on any expansion cabinets.**

Read the documentation supplied with each type of expansion cabinet for specific instructions.
4. **Power on the RTS power switches (FIGURE 2-13).**

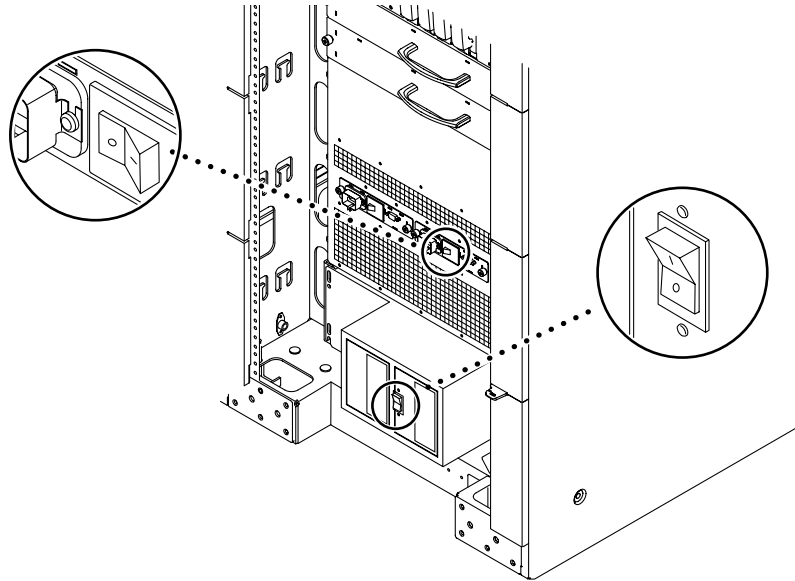

FIGURE 2-13 Sun Fire 6800 System Power Switch Locations

5. Power on the AC input box power switches (FIGURE 2-13).
6. Turn the FrameManager key to the on position.

The FrameManager key can be found in the shipping carton. If the FrameManager key cannot be located, the system key can be used.

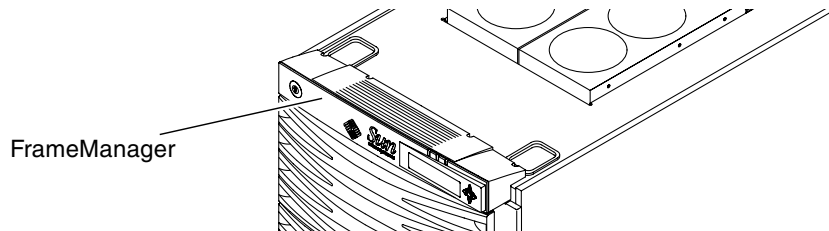

FIGURE 2-14 FrameManager Location—Front View



Caution – Never move the system or expansion cabinets when system power is on. Excessive movement can cause catastrophic disk drive failure. Always power off the system before moving it.

7. For instructions on adding additional hardware, refer to the documentation that came with the additional hardware.

8. For instructions on powering on the power grids, configuring the system, and creating additional domains, refer to the *Sun Fire Midrange Systems Platform Administration Manual*.

2.8 Powering Off the Sun Fire 6800 System



Caution – Failure to halt the operating system properly can cause the loss of disk drive data.



Caution – To avoid damaging internal circuits, do not connect or disconnect any cable while power is applied to the system.

1. **Notify users that the system is going down.**
2. **Back up the system files and data to tape, if necessary.**
3. **Halt the Solaris operating system.**
Refer to the *Sun Fire Midrange Systems Platform Administration Manual* for instructions on halting the operating system.
4. **Wait for the system-halted message and the boot monitor prompt.**
5. **Turn off the system power in this order:**
 1. External drives and expansion cabinets (if any)
 2. System cabinet AC power switch

2.9 Installing Additional Hardware

Note – Do not install additional hardware (system boards, interface cards, or power supply modules) until the initial factory configuration has been completely installed and the Sun Fire system has been powered on and completed POST successfully. This makes it easier to diagnose conflicts that may be caused by additional installations.

During initial installation, shut power off to the system before removing or replacing system hardware. Refer to the installation guide for the additional hardware for additional instructions

2.10 Installing Peripheral Devices

When you add additional storage devices, refer to the *Rackmount Placement Matrix*, at <http://docs.sun.com> for mounting hole numbers for mounting screws for Sun disk arrays and other storage trays and devices.

Unless otherwise specified in the *Rackmount Placement Matrix*, mount the heaviest subassemblies at the lowest available opening to minimize the effects of earthquakes.

Refer to the installation guide for the peripheral device for additional instructions.

Installing the Sun Fire 4810 System

This chapter contains information on installing a Sun Fire 4810 system.

- Mounting a Sun Fire 4810 System—[page 2-1](#)
- Connecting the Power Cables—[page 2-2](#)
- Connecting the I/O Assemblies—[page 2-2](#)
- Connecting the Administrative Console—[page 2-4](#)
- Powering On the Sun Fire 4810 System—[page 2-6](#)
- Powering Off the Sun Fire 4810 System—[page 2-6](#)
- Installing Additional Hardware—[page 2-6](#)
- Installing Peripheral Devices—[page 2-7](#)
- cPCI Card Visibility Issues—[page 2-7](#)



Caution – The Sun Fire 4810 system weighs approximately 305 lbs (138.3 kg). To prevent personal injury, two people are needed to move the system safely into the cabinet using a computer equipment lift.

Note – When you receive your system, leave it in the shipping crate at its final destination *for 24 hours* to prevent thermal shock and condensation.

3.1 Mounting a Sun Fire 4810 System

For instructions on mounting a Sun Fire 4810 system in an industry standard 19-inch rack, refer to the mounting instructions that accompanied the rack. The Sun Fire 4810 system is 16 rack units (RU) in height.

For instructions on mounting the Sun Fire 4810 system into a Sun Fire cabinet, refer to the *Sun Fire 4810/4800/3800 Systems Cabinet Mounting Guide*.

Note – Hardware necessary to mount the Sun Fire 4810 system in a Sun Fire cabinet (Y-serial cables, mounting brackets) is included in the shipping kit. Do not discard any extra hardware.

3.2 Connecting Power Cables

1. Turn each power switch to the off position (FIGURE 3-1).
2. Connect the power cord to the power cord socket on the system.
3. Loosen the screw above the power cord socket.
This will loosen the bracket that holds the tie wrap.
4. Position the bracket tightly against the power cord.
5. Tighten the tie wrap around the power cord to keep it from being dislodged.
Make sure the tie wrap is tight. Do not trim excess tie wrap.
6. Tighten the screw above the power cord socket.
7. Repeat Step 2 through Step 6 for each of the three power cords.
8. Connect the other end of each power cord to a different grounded circuit breaker.
The power supply cords should each be connected to a different 200–240 VAC, 30A circuit breaker. This prevents the entire system from going down if a single circuit breaker fails.

3.3 Connecting the I/O Assemblies

The I/O assemblies provide network interface and peripheral access for the domains (FIGURE 3-1).

Note – Domains cannot share I/O assemblies. If configuring a system with two domains make sure that each I/O assembly includes its own network interface card and peripherals.

1. Connect one end of the I/O cable to the appropriate card in the I/O assembly.

2. Connect the other end to the hub, workstation or peripheral.
3. Repeat Step 1 and 2 for each I/O cable.

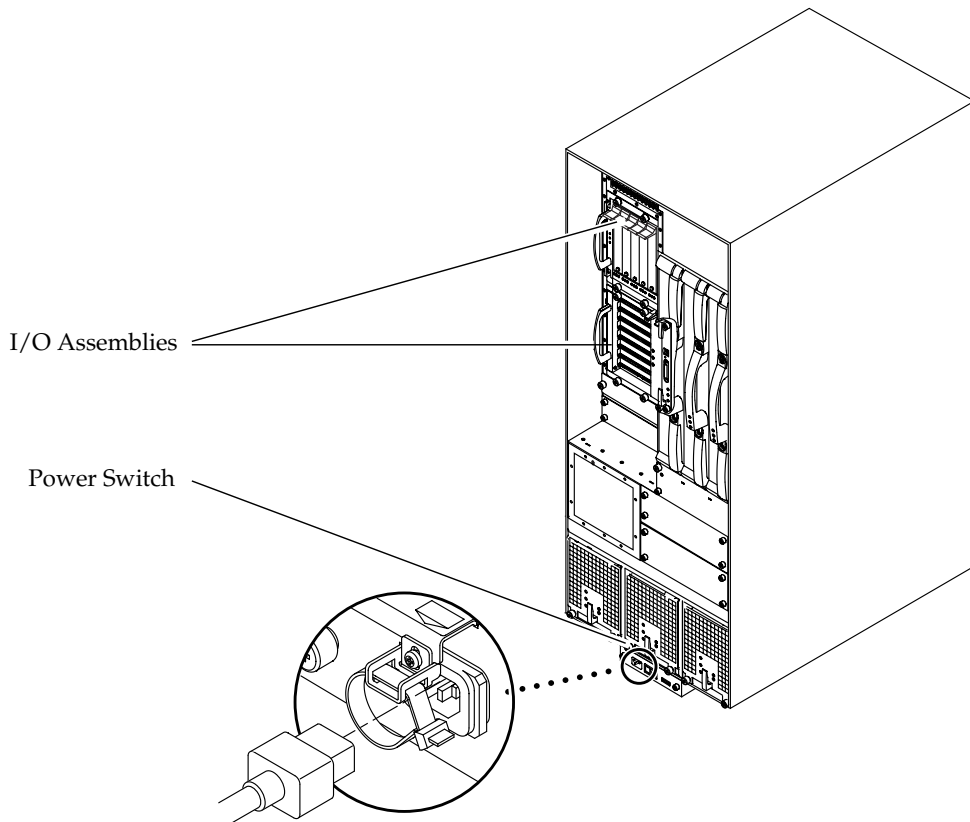

FIGURE 3-1 Power Switch, Power Cord Socket and I/O Assembly Locations on the Sun Fire 4810 System

3.4 Connecting the Administrative Console

The administrative console is used to access the primary System Controller board (SSC0) and set up the system and control the system controller software. The administrative console can be any external input device (such as a laptop computer or a workstation) connected to the primary (bottom) System Controller board.

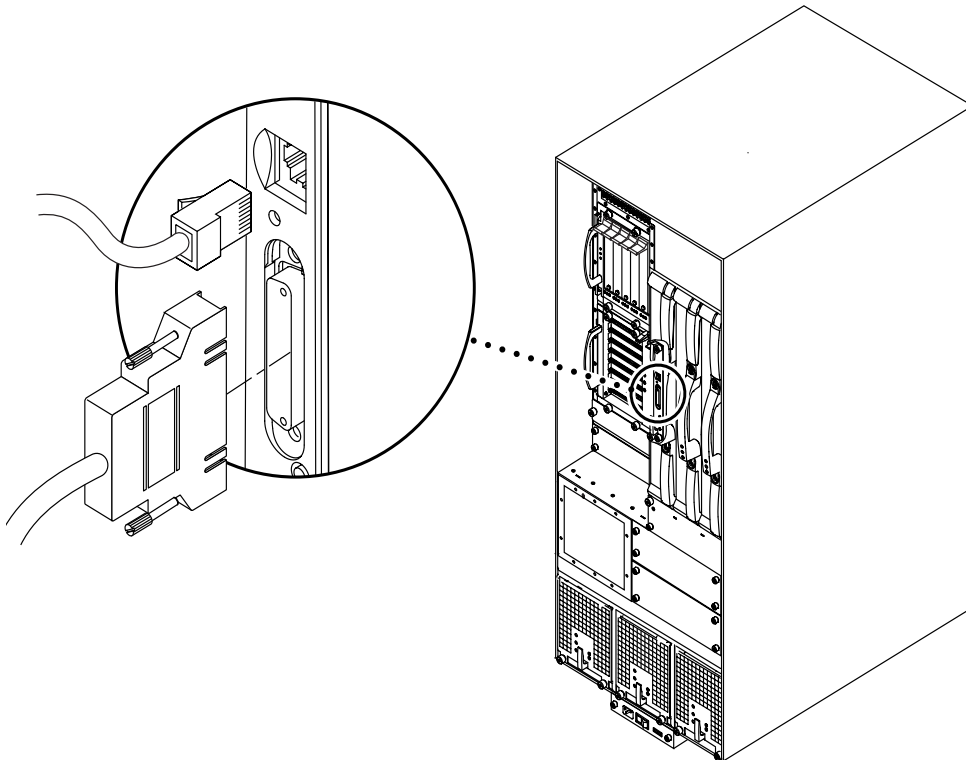

FIGURE 3-2 Primary System Controller Connections on the Sun Fire 4810 System

3.4.1 Connecting the ASCII terminal

The initial system setup requires an ASCII terminal connected to the TTYa serial port on the System Controller board using a null modem cable or through a network terminal server (NTS).

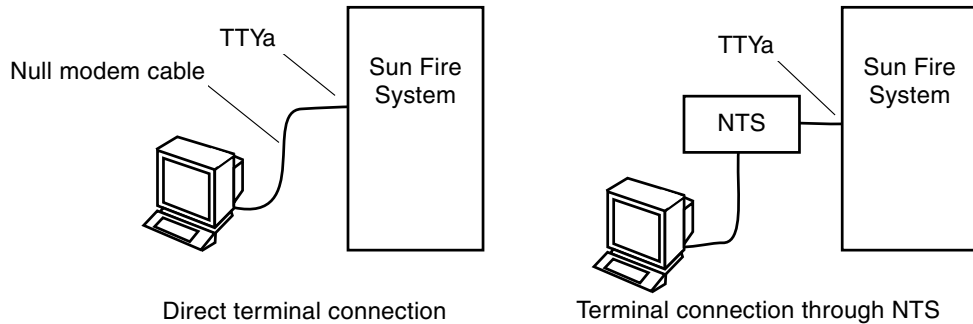

FIGURE 3-3 Serial Cable Connections

1. Connect one end of the serial cable (TTYa or Null modem) to the serial port on the primary System Controller board (FIGURE 3-2).
2. Connect the other end of the serial cable to the chosen ASCII terminal or NTS server (FIGURE 3-3).
3. Set up the chosen ASCII terminal as an administrative console.

Refer to the *Sun Fire Midrange Systems Platform Administration Manual* for instructions on setting up the ASCII terminal as an administrative console.

3.4.2 Connecting the Administrative Console

Once the system is set up, most system administration tasks can be performed through the network via the RJ-45 Ethernet port on the primary System Controller board.

1. Connect one end of the shielded Category-5 Ethernet cable to the RJ-45 Ethernet port on the primary System Controller board (FIGURE 3-2).
2. Connect the other end of the shielded Category-5 Ethernet cable to the chosen administrative console (local hub, router, or switch).
3. Set up the chosen administrative console.

Refer to the *Sun Fire Midrange Systems Platform Administration Manual* for instructions on setting up the administrative console.

3.5 Powering On the Sun Fire 4810 System

1. Turn each power switch to the on position (FIGURE 3-1).

If the system is in a Sun Fire cabinet, the cabinet will have to be turned on first. Refer to the *Sun Fire Cabinet Installation and Reference Manual*.

2. Power on the system.

Refer to the *Sun Fire Midrange Systems Platform Administration Manual* for procedures on software power on.

3.6 Powering Off the Sun Fire 4810 System

1. Notify users that the system is going down.
2. Back up the system files and data to tape, if necessary.
3. Halt the Solaris operating system.
Refer to the *Sun Fire Midrange Systems Platform Administration Manual* for instructions on halting the operating system.6800/6800/4810/4800/3800
4. Wait for the system-halted message and the boot monitor prompt.
5. Turn off each external drive and expansion cabinets (if any)
6. Turn each power switch to the on position (FIGURE 3-1).

3.7 Installing Additional Hardware

Note – Do not install additional hardware (system boards, interface cards, or power supply modules) until the initial factory configuration has been completely installed and the Sun Fire system has been powered on and completed POST successfully. This makes it easier to diagnose conflicts that may be caused by additional installations.

During initial installation, shut power off to the system before removing or replacing system hardware. Refer to the installation guide for the additional hardware for additional instructions.

3.8 Installing Peripheral Devices

When you add additional storage devices, refer to the *Rackmount Placement Matrix*, at <http://docs.sun.com> for mounting hole numbers for mounting screws for Sun disk arrays and other storage trays and devices.

Unless otherwise specified in the *Rackmount Placement Matrix*, mount the heaviest subassemblies at the lowest available opening to minimize the effects of earthquakes.

Refer to the installation guide for the peripheral device for additional instructions.

3.9 cPCI Card Visibility Issues

Note – Make sure to leave at least 1 ^{1/2} card length of free cable for every cable connection. This facilitate removal or installation of adjacent adapters.

The visibility of Slot0 and of any adapter connectors in this slot is reduced. Exercise suitable caution while cabling, and/or observing the Hot-swap indicators on the card and I/O assembly.

When cabling adapters with double connectors, note that some adapters reverse the orientation and keying of the connectors between the pair. A cable attached to one connector will be rotated a half turn to attach to the other connector and this may not be obvious under the visibility conditions at the I/O assembly.

When attaching two cables to adapters with double connectors, one above the other, cabling the lower port first will provide greater visibility of the connector.

When removing adapters with double connectors and particularly with heavy cables (like SCSI), it is recommended that both cables be disconnected from the adapter before attempting adapter Hot-Removal from the I/O assembly. This eases the removal effort and reduce the likelihood of damage to the cards and cables.

Installing the Sun Fire 4800 System

This chapter contains information on installing a Sun Fire 4800 system.

- Mounting a Sun Fire 4800 System—[page 3-1](#)
- Connecting the Power Cables—[page 3-2](#)
- Connecting the I/O Assemblies—[page 3-2](#)
- Connecting the Administrative Console—[page 3-4](#)
- Powering On the Sun Fire 4800 System—[page 3-6](#)
- Powering Off the Sun Fire 4800 System—[page 3-6](#)
- Installing Additional Hardware—[page 3-6](#)
- Installing Peripheral Devices—[page 3-7](#)
- cPCI Card Visibility Issues—[page 3-7](#)



Caution – The Sun Fire 4800 system weighs approximately 289 lbs (131.1 kg). To prevent personal injury, two people are needed to move the system safely into the cabinet using a computer equipment lift.

Note – When you receive your system, leave it in the shipping crate at its final destination *for 24 hours* to prevent thermal shock and condensation.

4.1 Mounting a Sun Fire 4800 System

For instructions on mounting a Sun Fire 4800 system in an industry standard 19-inch rack, refer to the mounting instructions that accompanied the rack. The Sun Fire 4800 system is 13.3 rack units (RU) in height.

For instructions on mounting the Sun Fire 4800 system into a Sun Fire cabinet refer to the *Sun Fire 4810/4800/3800 Systems Cabinet Mounting Guide*.

Note – Hardware necessary to mount the Sun Fire 4800 system in a Sun Fire cabinet (Y-serial cables, mounting brackets) is included in the shipping kit. Do not discard any extra hardware.

4.2 Connecting Power Cables to the Sun Fire 4800 System

1. Turn each power switch to the off position (FIGURE 4-1).
2. Connect the power cord to the power cord socket on the system.
3. Loosen the screw above the power cord socket.
This will loosen the bracket that holds the tie wrap.
4. Position the bracket tightly against the power cord.
5. Tighten the tie wrap around the power cord to keep it from being dislodged.
Make sure the tie wrap is tight. Do not trim excess tie wrap.
6. Tighten the screw above the power cord socket.
7. Repeat Step 2 through Step 6 for each of the three power cords.
8. Connect the other end of each power cord to a different grounded circuit breaker.
The power supply cords should each be connected to a different 200–240 VAC, 15A circuit breaker. This prevents the entire system from going down if a single circuit breaker fails.

4.3 Connecting the I/O Assemblies

The I/O assemblies provide network interface and peripheral access for the domains (FIGURE 4-1).

Note – Domains cannot share I/O assemblies. If configuring a system with two domains make sure that each I/O assembly includes its own network interface card and peripherals.

1. Connect one end of the I/O cable to the appropriate card in the I/O assembly.
2. Connect the other end to the hub, workstation or peripheral.
3. Repeat Step 1 and 2 for each I/O cable.

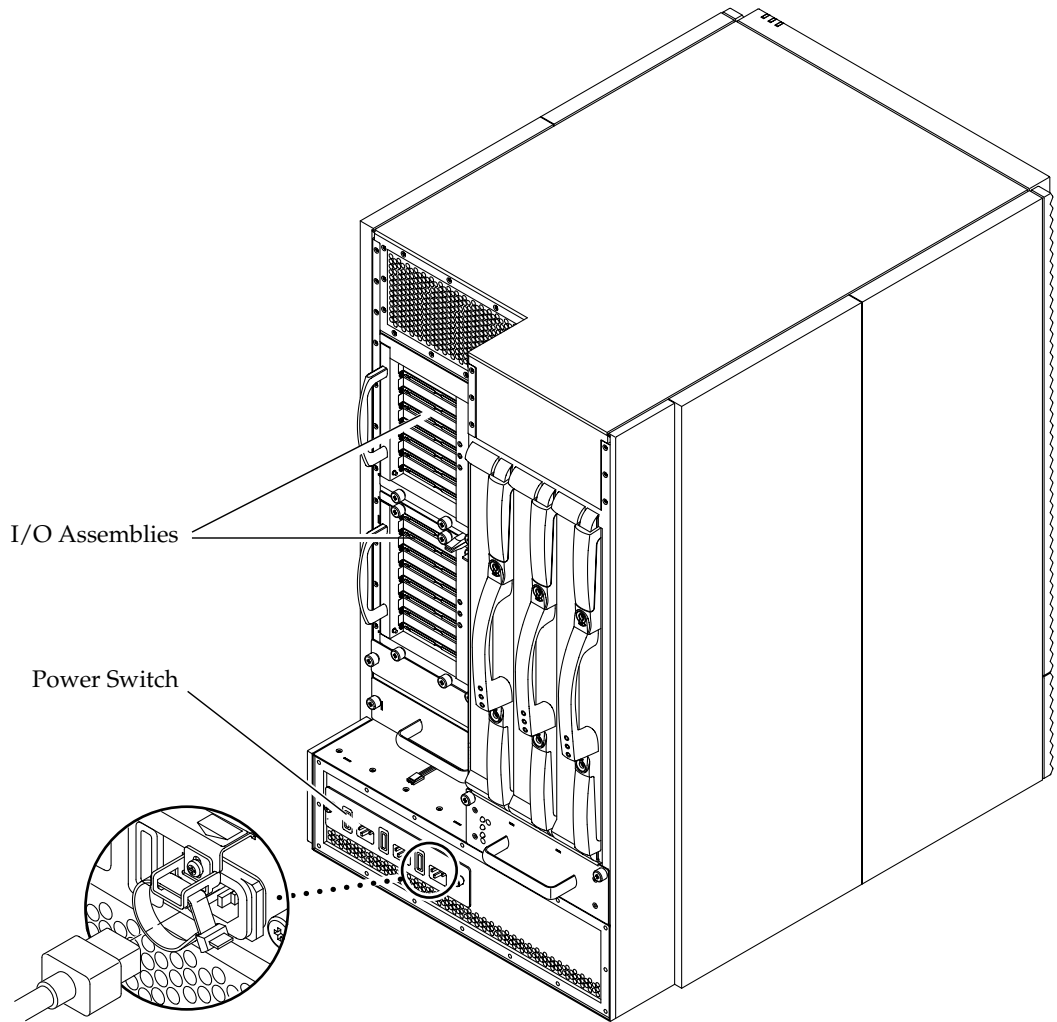

FIGURE 4-1 Power Switch, Power Cord Socket and I/O Assembly Locations on the Sun Fire 4800 System

4.4 Connecting the Administrative Console

The administrative console is used to access the primary System Controller board (SSC0) and set up the system and control the system controller software. The administrative console can be any external input device (such as a laptop computer or a workstation) connected to the primary (bottom) System Controller board.

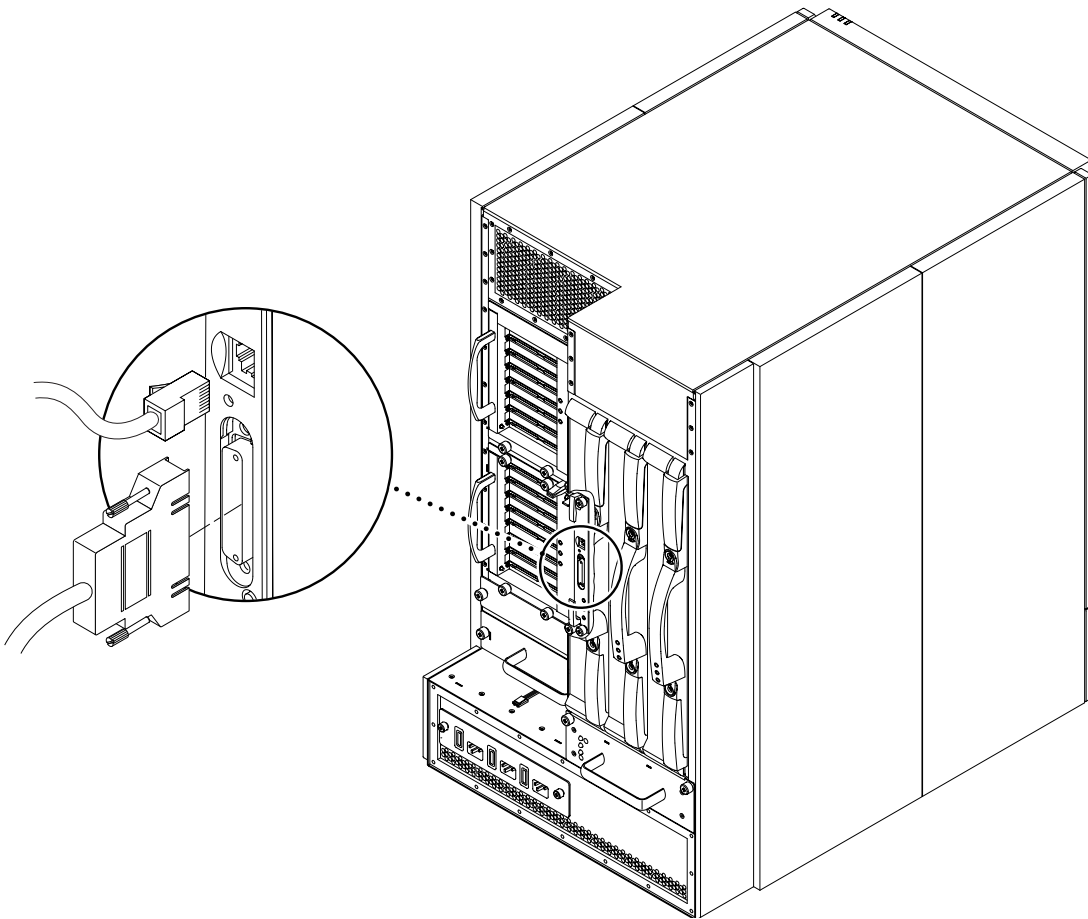

FIGURE 4-2 Primary System Controller Connections on the Sun Fire 4800 System

4.4.1 Connecting the ASCII terminal

The initial system setup requires an ASCII terminal connected to the TTYa serial port on the System Controller board using a null modem cable or through a network terminal server (NTS).

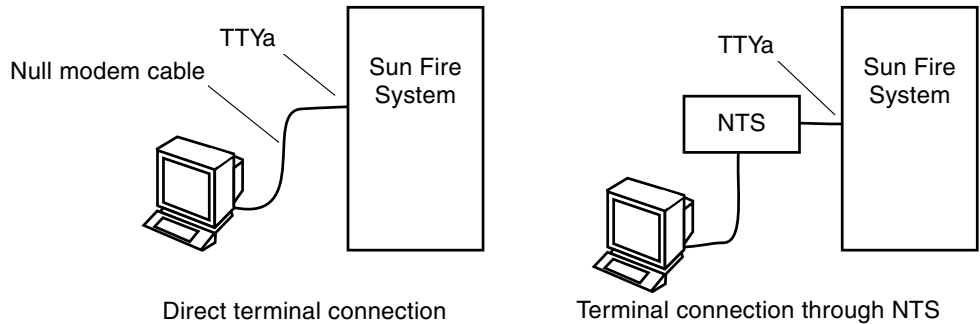

FIGURE 4-3 Serial Cable Connections

1. Connect one end of the serial cable (TTYa or Null modem) to the serial port on the primary System Controller board (FIGURE 4-2).
2. Connect the other end of the serial cable to the chosen ASCII terminal or NTS server (FIGURE 4-3).
3. Set up the chosen ASCII terminal as an administrative console.

Refer to the *Sun Fire Midrange Systems Platform Administration Manual* for instructions on setting up the ASCII terminal as an administrative console.

4.4.2 Connecting the Administrative Console

Once the system is set up, most system administration tasks can be performed through the network via the RJ-45 Ethernet port on the primary System Controller board.

1. Connect one end of the shielded Category-5 Ethernet cable to the RJ-45 Ethernet port on the primary System Controller board (FIGURE 4-2).
2. Connect the other end of the shielded Category-5 Ethernet cable to the chosen administrative console (local hub, router, or switch).
3. Set up the chosen administrative console.

Refer to the *Sun Fire Midrange Systems Platform Administration Manual* for instructions on setting up the administrative console.

4.5 Powering On the Sun Fire 4800 System

1. Turn each power switch to the on position (FIGURE 4-1).

If the system is in a Sun Fire cabinet, the cabinet will have to be turned on first. Refer to the *Sun Fire Cabinet Installation and Reference Manual*.

2. Power on the system.

Refer to the *Sun Fire Midrange Systems Platform Administration Manual* for procedures on software power on.

4.6 Powering Off the Sun Fire 4800 System

1. Notify users that the system is going down.
2. Back up the system files and data to tape, if necessary.
3. Halt the Solaris operating system.

Refer to the *Sun Fire Midrange Systems Platform Administration Manual* for instructions on halting the operating system.

4. Wait for the system-halted message and the boot monitor prompt.
5. Turn off each external drive and expansion cabinets (if any)
6. Turn each power switch to the on position (FIGURE 4-1).

4.7 Installing Additional Hardware

Note – Do not install additional hardware (system boards, interface cards, or power supply modules) until the initial factory configuration has been completely installed and the Sun Fire system has been powered on and completed POST successfully. This makes it easier to diagnose conflicts that may be caused by additional installations.

During initial installation, shut power off to the system before removing or replacing system hardware. Refer to the installation guide for the additional hardware for additional instructions.

4.8 Installing Peripheral Devices

When you add additional storage devices, refer to the *Rackmount Placement Matrix*, at <http://docs.sun.com> for mounting hole numbers for mounting screws for Sun disk arrays and other storage trays and devices.

Unless otherwise specified in the *Rackmount Placement Matrix*, mount the heaviest subassemblies at the lowest available opening to minimize the effects of earthquakes.

Refer to the installation guide for the peripheral device for additional instructions.

4.9 cPCI Card Visibility Issues

Note – Make sure to leave at least 1 ^{1/2} card length of free cable for every cable connection. This facilitate removal or installation of adjacent adapters.

The visibility of Slot0 and of any adapter connectors in this slot is reduced. Exercise suitable caution while cabling, and/or observing the Hot-swap indicators on the card and I/O assembly.

When cabling adapters with double connectors, note that some adapters reverse the orientation and keying of the connectors between the pair. A cable attached to one connector will be rotated a half turn to attach to the other connector and this may not be obvious under the visibility conditions at the I/O assembly.

When attaching two cables to adapters with double connectors, one above the other, cabling the lower port first will provide greater visibility of the connector.

When removing adapters with double connectors and particularly with heavy cables (like SCSI), it is recommended that both cables be disconnected from the adapter before attempting adapter Hot-Removal from the I/O assembly. This eases the removal effort and reduce the likelihood of damage to the cards and cables.

Installing the Sun Fire 3800 System

This chapter contains information on installing a Sun Fire 3800 system.

- Mounting a Sun Fire 3800 System—[page 4-1](#)
- Connecting the Power Cables—[page 4-2](#)
- Connecting the I/O Assemblies—[page 4-2](#)
- Connecting the Administrative Console—[page 4-4](#)
- Powering On the Sun Fire 3800 System —[page 4-6](#)
- Powering Off the Sun Fire 3800 System —[page 4-6](#)
- Installing Additional Hardware—[page 4-6](#)
- Installing Peripheral Devices—[page 4-7](#)
- cPCI Card Visibility Issues—[page 4-7](#)



Caution – The Sun Fire 3800 system weighs approximately 200 lbs (90.7 kg). To prevent personal injury, two people are needed to move the system safely into the cabinet using a computer equipment lift.

Note – When you receive your system, leave it in the shipping crate at its final destination *for 24 hours* to prevent thermal shock and condensation.

5.1 Mounting a Sun Fire 3800 System

For instructions on mounting a Sun Fire 3800 system in an industry standard 19-inch rack, refer to the mounting instructions that accompanied the rack. The Sun Fire 3800 system is 6.5 rack units (RU) in height.

For instructions on mounting the Sun Fire 3800 systems into a Sun Fire cabinet refer to the *Sun Fire 4810/4800/3800 Systems Cabinet Mounting Guide*.

Note – Hardware necessary to mount the Sun Fire 3800 system in a Sun Fire cabinet (Y-serial cables, mounting brackets) is included in the shipping kit. Do not discard any extra hardware.

5.2 Connecting Power Cables to the Sun Fire 3800 System

1. Turn each power switch to the off position (FIGURE 5-1).
2. Connect the power cord to the power cord sockets on the system.
3. Tighten the tie wrap around each power cord and around the power supply handle to keep them from being dislodged.

Make sure the tie wrap is tight. Do not trim excess tie wrap.

4. Repeat Step 2 and Step 3 for each of the three power cords.
5. Connect the other ends of the power cord to a grounded circuit breaker.

The power supply cords should each be connected to a different 100-120 or 200-240 VAC, 15A circuit breaker. This prevents the entire system from going down if a single circuit breaker fails.

5.3 Connecting the I/O Assemblies

The I/O assemblies provide network interface and peripheral access for the domains (FIGURE 5-2).

Note – Domains cannot share I/O assemblies. If configuring a system with two domains make sure that each I/O assembly includes its own network interface card and peripherals.

1. Connect one end of the I/O cable to the appropriate card in the I/O assembly.
2. Connect the other end to the hub, workstation or peripheral.

3. Repeat Step 1 and 2 for each I/O cable.

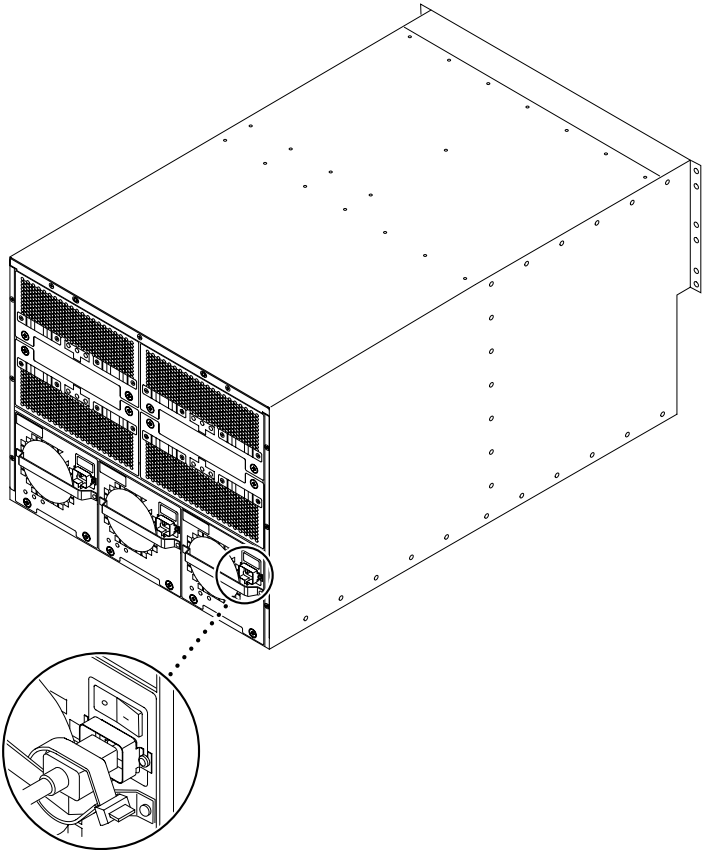

FIGURE 5-1 Power Switch and Power Cord Socket Locations on the Sun Fire 3800 System

5.4 Connecting the Administrative Console

The administrative console is used to access the primary System Controller board (SSC0) and set up the system and control the system controller software. The administrative console can be any external input device (such as a laptop computer or a workstation) connected to the primary (bottom) System Controller board.

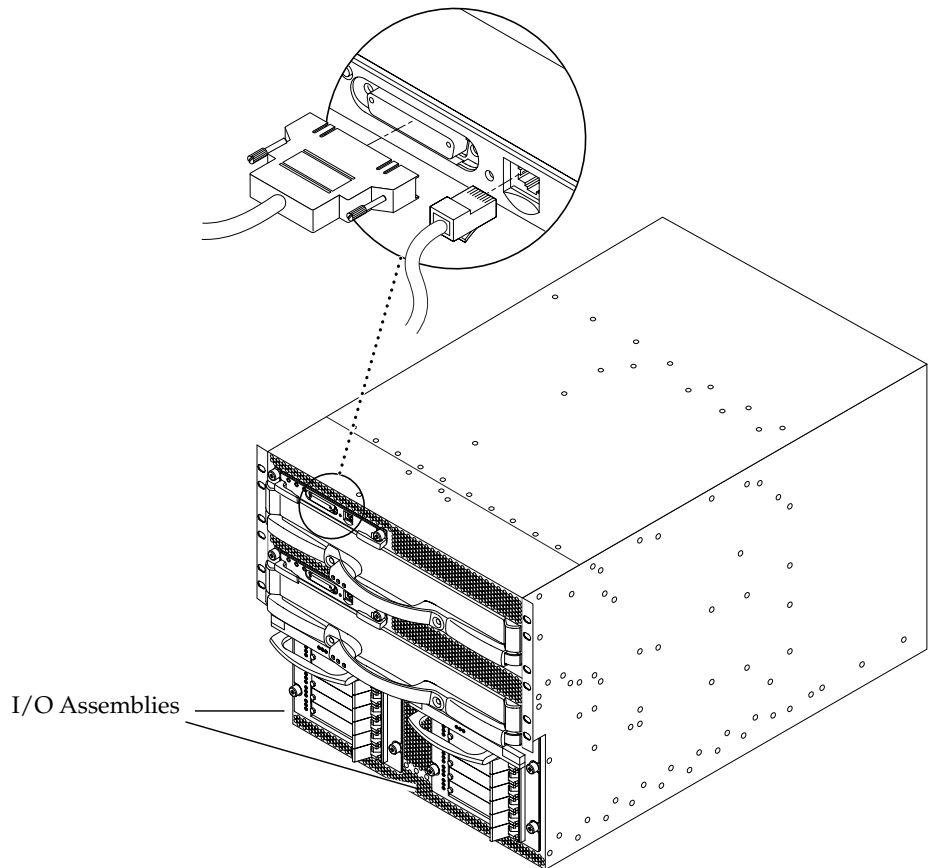

FIGURE 5-2 System Controller and I/O Assembly Locations on the Sun Fire 3800 System

5.4.1 Connecting the ASCII terminal

The initial system setup requires an ASCII terminal connected to the TTYa serial port on the System Controller board using a null modem cable or through a network terminal server (NTS).

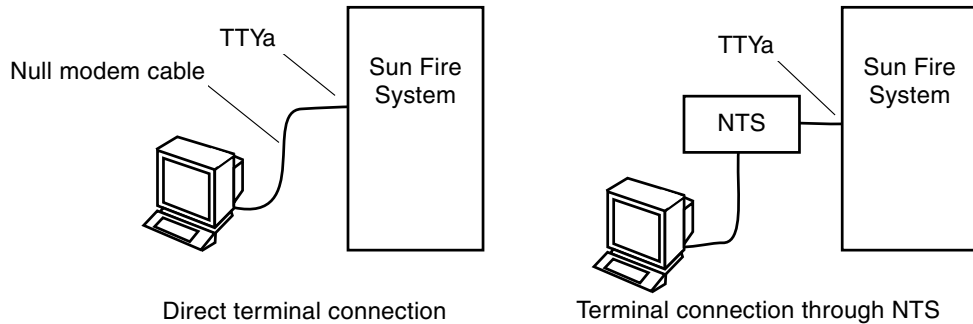

FIGURE 5-3 Serial Cable Connections

1. Connect one end of the serial cable (TTYa or Null modem) to the serial port on the primary System Controller board (FIGURE 5-2).
2. Connect the other end of the serial cable to the chosen ASCII terminal or NTS server (FIGURE 5-3).
3. Set up the chosen ASCII terminal as an administrative console.

Refer to the *Sun Fire Midrange Systems Platform Administration Manual* for instructions on setting up the ASCII terminal as an administrative console.

5.4.2 Connecting the Administrative Console

Once the system is set up, most system administration tasks can be performed through the network via the RJ-45 Ethernet port on the primary System Controller board.

1. Connect one end of the shielded Category-5 Ethernet cable to the RJ-45 Ethernet port on the primary System Controller board (FIGURE 5-2).
2. Connect the other end of the shielded Category-5 Ethernet cable to the chosen administrative console (local hub, router, or switch).
3. Set up the chosen administrative console.

Refer to the *Sun Fire Midrange Systems Platform Administration Manual* for instructions on setting up the administrative console.

5.5 Powering On the Sun Fire 3800 System

1. Turn each power switch to the on position (FIGURE 5-1).

If the system is in a Sun Fire cabinet, the cabinet will have to be turned on first. Refer to the *Sun Fire Cabinet Installation and Reference Manual*.

2. Power on the system.

Refer to the *Sun Fire Midrange Systems Platform Administration Manual* for procedures on software power on.

5.6 Powering Off the Sun Fire 3800 System

1. Notify users that the system is going down.
2. Back up the system files and data to tape, if necessary.
3. Halt the Solaris operating system.

Refer to the *Sun Fire Midrange Systems Platform Administration Manual* for instructions on halting the operating system.

4. Wait for the system-halted message and the boot monitor prompt.
5. Turn off each external drive and expansion cabinets (if any)
6. Turn each power switch to the on position (FIGURE 5-1).

5.7 Installing Additional Hardware

Note – Do not install additional hardware (system boards, interface cards, or power supply modules) until the initial factory configuration has been completely installed and the Sun Fire system has been powered on and completed POST successfully. This makes it easier to diagnose conflicts that may be caused by additional installations.

During initial installation, shut power off to the system before removing or replacing system hardware. Refer to the installation guide for the additional hardware for additional instructions.

5.8 Installing Peripheral Devices

When you add additional storage devices, refer to the *Rackmount Placement Matrix*, at <http://docs.sun.com> for mounting hole numbers for mounting screws for Sun disk arrays and other storage trays and devices.

Unless otherwise specified in the *Rackmount Placement Matrix*, mount the heaviest subassemblies at the lowest available opening to minimize the effects of earthquakes.

Refer to the installation guide for the peripheral device for additional instructions.

5.9 cPCI Card Visibility Issues

Note – Make sure to leave at least 1 ^{1/2} card length of free cable for every cable connection. This facilitate removal or installation of adjacent adapters.

The visibility of Slot0 and of any adapter connectors in this slot is reduced. Exercise suitable caution while cabling, and/or observing the Hot-swap indicators on the card and I/O assembly.

When cabling adapters with double connectors, note that some adapters reverse the orientation and keying of the connectors between the pair. A cable attached to one connector will be rotated a half turn to attach to the other connector and this may not be obvious under the visibility conditions at the I/O assembly.

When attaching two cables to adapters with double connectors, one above the other, cabling the lower port first will provide greater visibility of the connector.

When removing adapters with double connectors and particularly with heavy cables (like SCSI), it is recommended that both cables be disconnected from the adapter before attempting adapter Hot-Removal from the I/O assembly. This eases the removal effort and reduce the likelihood of damage to the cards and cables.

