



Sun Fire™ B10n Content Load Balancing Blade Administration Guide

Sun Microsystems, Inc.
4150 Network Circle
Santa Clara, CA 95054 U.S.A.
650-960-1300

Part No. 817-0627-10
June 2003, Revision A

Submit comments about this document at: <http://www.sun.com/hwdocs/feedback>

Copyright 2003 Sun Microsystems, Inc., 4150 Network Circle, Santa Clara, California 95054, U.S.A. All rights reserved.

Sun Microsystems, Inc. has intellectual property rights relating to technology embodied in the product that is described in this document. In particular, and without limitation, these intellectual property rights may include one or more of the U.S. patents listed at <http://www.sun.com/patents> and one or more additional patents or pending patent applications in the U.S. and in other countries.

This document and the product to which it pertains are distributed under licenses restricting their use, copying, distribution, and decompilation. No part of the product or of this document may be reproduced in any form by any means without prior written authorization of Sun and its licensors, if any.

Third-party software, including font technology, is copyrighted and licensed from Sun suppliers.

Parts of the product may be derived from Berkeley BSD systems, licensed from the University of California. UNIX is a registered trademark in the U.S. and in other countries, exclusively licensed through X/Open Company, Ltd.

Sun, Sun Microsystems, the Sun logo, AnswerBook2, docs.sun.com, Sun Fire, and Solaris are trademarks or registered trademarks of Sun Microsystems, Inc. in the U.S. and in other countries.

All SPARC trademarks are used under license and are trademarks or registered trademarks of SPARC International, Inc. in the U.S. and in other countries. Products bearing SPARC trademarks are based upon an architecture developed by Sun Microsystems, Inc.

The OPEN LOOK and Sun™ Graphical User Interface was developed by Sun Microsystems, Inc. for its users and licensees. Sun acknowledges the pioneering efforts of Xerox in researching and developing the concept of visual or graphical user interfaces for the computer industry. Sun holds a non-exclusive license from Xerox to the Xerox Graphical User Interface, which license also covers Sun's licensees who implement OPEN LOOK GUIs and otherwise comply with Sun's written license agreements.

Use, duplication, or disclosure by the U.S. Government is subject to restrictions set forth in the Sun Microsystems, Inc. license agreements and as provided in DFARS 227.7202-1(a) and 227.7202-3(a) (1995), DFARS 252.227-7013(c)(1)(ii) (Oct. 1998), FAR 12.212(a) (1995), FAR 52.227-19, or FAR 52.227-14 (ALT III), as applicable.

DOCUMENTATION IS PROVIDED "AS IS" AND ALL EXPRESS OR IMPLIED CONDITIONS, REPRESENTATIONS AND WARRANTIES, INCLUDING ANY IMPLIED WARRANTY OF MERCHANTABILITY, FITNESS FOR A PARTICULAR PURPOSE OR NON-INFRINGEMENT, ARE DISCLAIMED, EXCEPT TO THE EXTENT THAT SUCH DISCLAIMERS ARE HELD TO BE LEGALLY INVALID.

Copyright 2003 Sun Microsystems, Inc., 4150 Network Circle, Santa Clara, California 95054, Etats-Unis. Tous droits réservés.

Sun Microsystems, Inc. a les droits de propriété intellectuelle relatant à la technologie incorporée dans le produit qui est décrit dans ce document. En particulier, et sans la limitation, ces droits de propriété intellectuelle peuvent inclure un ou plus des brevets américains énumérés à <http://www.sun.com/patents> et un ou les brevets plus supplémentaires ou les applications de brevet en attente dans les Etats-Unis et dans les autres pays.

Ce produit ou document est protégé par un copyright et distribué avec des licences qui en restreignent l'utilisation, la copie, la distribution, et la décompilation. Aucune partie de ce produit ou document ne peut être reproduite sous aucune forme, par quelque moyen que ce soit, sans l'autorisation préalable et écrite de Sun et de ses bailleurs de licence, s'il y en a.

Le logiciel détenu par des tiers, et qui comprend la technologie relative aux polices de caractères, est protégé par un copyright et licencié par des fournisseurs de Sun.

Des parties de ce produit pourront être dérivées des systèmes Berkeley BSD licenciés par l'Université de Californie. UNIX est une marque déposée aux Etats-Unis et dans d'autres pays et licenciée exclusivement par X/Open Company, Ltd.

Sun, Sun Microsystems, le logo Sun, AnswerBook2, docs.sun.com, Sun Fire, et Solaris sont des marques de fabrique ou des marques déposées de Sun Microsystems, Inc. aux Etats-Unis et dans d'autres pays.

Toutes les marques SPARC sont utilisées sous licence et sont des marques de fabrique ou des marques déposées de SPARC International, Inc. aux Etats-Unis et dans d'autres pays. Les produits portant les marques SPARC sont basés sur une architecture développée par Sun Microsystems, Inc.

L'interface d'utilisation graphique OPEN LOOK et Sun™ a été développée par Sun Microsystems, Inc. pour ses utilisateurs et licenciés. Sun reconnaît les efforts de pionniers de Xerox pour la recherche et le développement du concept des interfaces d'utilisation visuelle ou graphique pour l'industrie de l'informatique. Sun détient une licence non exclusive de Xerox sur l'interface d'utilisation graphique Xerox, cette licence couvrant également les licenciés de Sun qui mettent en place l'interface d'utilisation graphique OPEN LOOK et qui en outre se conforment aux licences écrites de Sun.

LA DOCUMENTATION EST FOURNIE "EN L'ÉTAT" ET TOUTES AUTRES CONDITIONS, DECLARATIONS ET GARANTIES EXPRESSES OU TACITES SONT FORMELLEMENT EXCLUES, DANS LA MESURE AUTORISÉE PAR LA LOI APPLICABLE, Y COMPRIS NOTAMMENT TOUTE GARANTIE IMPLICITE RELATIVE A LA QUALITE MARCHANDE, A L'APTITUDE A UNE UTILISATION PARTICULIERE OU A L'ABSENCE DE CONTREFAÇON.



Regulatory Compliance Statements

Your Sun product is marked to indicate its compliance class:

- Federal Communications Commission (FCC) — USA
- Industry Canada Equipment Standard for Digital Equipment (ICES-003) — Canada
- Voluntary Control Council for Interference (VCCI) — Japan
- Bureau of Standards Metrology and Inspection (BSMI) — Taiwan

Please read the appropriate section that corresponds to the marking on your Sun product before attempting to install the product.

FCC Class A Notice

This device complies with Part 15 of the FCC Rules. Operation is subject to the following two conditions:

1. This device may not cause harmful interference.
2. This device must accept any interference received, including interference that may cause undesired operation.

Note: This equipment has been tested and found to comply with the limits for a Class A digital device, pursuant to Part 15 of the FCC Rules. These limits are designed to provide reasonable protection against harmful interference when the equipment is operated in a commercial environment. This equipment generates, uses, and can radiate radio frequency energy, and if it is not installed and used in accordance with the instruction manual, it may cause harmful interference to radio communications. Operation of this equipment in a residential area is likely to cause harmful interference, in which case the user will be required to correct the interference at his own expense.

Shielded Cables: Connections between the workstation and peripherals must be made using shielded cables to comply with FCC radio frequency emission limits. Networking connections can be made using unshielded twisted-pair (UTP) cables.

Modifications: Any modifications made to this device that are not approved by Sun Microsystems, Inc. may void the authority granted to the user by the FCC to operate this equipment.

FCC Class B Notice

This device complies with Part 15 of the FCC Rules. Operation is subject to the following two conditions:

1. This device may not cause harmful interference.
2. This device must accept any interference received, including interference that may cause undesired operation.

Note: This equipment has been tested and found to comply with the limits for a Class B digital device, pursuant to Part 15 of the FCC Rules. These limits are designed to provide reasonable protection against harmful interference in a residential installation. This equipment generates, uses and can radiate radio frequency energy and, if not installed and used in accordance with the instructions, may cause harmful interference to radio communications. However, there is no guarantee that interference will not occur in a particular installation. If this equipment does cause harmful interference to radio or television reception, which can be determined by turning the equipment off and on, the user is encouraged to try to correct the interference by one or more of the following measures:

- Reorient or relocate the receiving antenna.
- Increase the separation between the equipment and receiver.
- Connect the equipment into an outlet on a circuit different from that to which the receiver is connected.
- Consult the dealer or an experienced radio/television technician for help.

Shielded Cables: Connections between the workstation and peripherals must be made using shielded cables in order to maintain compliance with FCC radio frequency emission limits. Networking connections can be made using unshielded twisted pair (UTP) cables.

Modifications: Any modifications made to this device that are not approved by Sun Microsystems, Inc. may void the authority granted to the user by the FCC to operate this equipment.

ICES-003 Class A Notice - Avis NMB-003, Classe A

This Class A digital apparatus complies with Canadian ICES-003.

Cet appareil numérique de la classe A est conforme à la norme NMB-003 du Canada.

ICES-003 Class B Notice - Avis NMB-003, Classe B

This Class B digital apparatus complies with Canadian ICES-003.

Cet appareil numérique de la classe B est conforme à la norme NMB-003 du Canada.

VCCI 基準について

クラス A VCCI 基準について

クラス A VCCI の表示があるワークステーションおよびオプション製品は、クラス A 情報技術装置です。これらの製品には、下記の項目が該当します。

この装置は、情報処理装置等電波障害自主規制協議会 (VCCI) の基準に基づくクラス A 情報技術装置です。この装置を家庭環境で使用すると電波妨害を引き起こすことがあります。この場合には使用者が適切な対策を講ずるよう要求されることがあります。

クラス B VCCI 基準について

クラス B VCCI の表示  があるワークステーションおよびオプション製品は、クラス B 情報技術装置です。これらの製品には、下記の項目が該当します。

この装置は、情報処理装置等電波障害自主規制協議会 (VCCI) の基準に基づくクラス B 情報技術装置です。この装置は、家庭環境で使用することを目的としていますが、この装置がラジオやテレビジョン受信機に近接して使用されると、受信障害を引き起こすことがあります。取扱説明書に従って正しい取り扱いをしてください。

BSMI Class A Notice

The following statement is applicable to products shipped to Taiwan and marked as Class A on the product compliance label.

警告使用者：

這是甲類的資訊產品，在居住的環境中使用時，可能會造成射頻干擾，在這種情況下，使用者會被要求採取某些適當的對策。

Safety Agency Compliance Statements

Read this section before beginning any procedure. The following text provides safety precautions to follow when installing a Sun Microsystems product.

Safety Precautions

For your protection, observe the following safety precautions when setting up your equipment:

- Follow all cautions and instructions marked on the equipment.
- Ensure that the voltage and frequency of your power source match the voltage and frequency inscribed on the equipment's electrical rating label.
- Never push objects of any kind through openings in the equipment. Dangerous voltages may be present. Conductive foreign objects could produce a short circuit that could cause fire, electric shock, or damage to your equipment.

Symbols

The following symbols may appear in this book:



Caution – There is a risk of personal injury and equipment damage. Follow the instructions.



Caution – Hot surface. Avoid contact. Surfaces are hot and may cause personal injury if touched.



Caution – Hazardous voltages are present. To reduce the risk of electric shock and danger to personal health, follow the instructions.



On – Applies AC power to the system.

Depending on the type of power switch your device has, one of the following symbols may be used:



Off – Removes AC power from the system.



Standby – The On/Standby switch is in the standby position.

Modifications to Equipment

Do not make mechanical or electrical modifications to the equipment. Sun Microsystems is not responsible for regulatory compliance of a modified Sun product.

Placement of a Sun Product



Caution – Do not block or cover the openings of your Sun product. Never place a Sun product near a radiator or heat register. Failure to follow these guidelines can cause overheating and affect the reliability of your Sun product.



Caution – The workplace-dependent noise level defined in DIN 45 635 Part 1000 must be 70Db(A) or less.

SELV Compliance

Safety status of I/O connections comply to SELV requirements.

Power Cord Connection



Caution – Sun products are designed to work with single-phase power systems having a grounded neutral conductor. To reduce the risk of electric shock, do not plug Sun products into any other type of power system. Contact your facilities manager or a qualified electrician if you are not sure what type of power is supplied to your building.



Caution – Not all power cords have the same current ratings. Household extension cords do not have overload protection and are not meant for use with computer systems. Do not use household extension cords with your Sun product.



Caution – Your Sun product is shipped with a grounding type (three-wire) power cord. To reduce the risk of electric shock, always plug the cord into a grounded power outlet.

The following caution applies only to devices with a Standby power switch:



Caution – The power switch of this product functions as a standby type device only. The power cord serves as the primary disconnect device for the system. Be sure to plug the power cord into a grounded power outlet that is nearby the system and is readily accessible. Do not connect the power cord when the power supply has been removed from the system chassis.

Lithium Battery



Caution – On Sun CPU boards, there is a lithium battery molded into the real-time clock, SGS No. MK48T59Y, MK48TXXB-XX, MK48T18-XXXPCZ, M48T59W-XXXPCZ, or MK48T08. Batteries are not customer replaceable parts. They may explode if mishandled. Do not dispose of the battery in fire. Do not disassemble it or attempt to recharge it.

Battery Pack



Caution – There is a sealed lead acid battery in Sun Fire B10n content load balancing blade units. Portable Energy Products No. TLC02V50. There is danger of explosion if the battery pack is mishandled or incorrectly replaced. Replace only with the same type of Sun Microsystems battery pack. Do not disassemble it or attempt to recharge it outside the system. Do not dispose of the battery in fire. Dispose of the battery properly in accordance with local regulations.

System Unit Cover

You must remove the cover of your Sun computer system unit to add cards, memory, or internal storage devices. Be sure to replace the top cover before powering on your computer system.



Caution – Do not operate Sun products without the top cover in place. Failure to take this precaution may result in personal injury and system damage.

Laser Compliance Notice

Sun products that use laser technology comply with Class 1 laser requirements.

Class 1 Laser Product
Luokan 1 Laserlaitte
Klasse 1 Laser Apparat
Laser Klasse 1

CD-ROM



Caution – Use of controls, adjustments, or the performance of procedures other than those specified herein may result in hazardous radiation exposure.

GOST-R Certification Mark

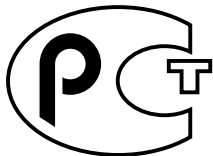

Conformité aux normes de sécurité

Lisez attentivement la section suivante avant de commencer la procédure. Le document ci-dessous présente les consignes de sécurité à respecter au cours de l'installation d'un produit Sun Microsystems.

Mesures de sécurité

Pour votre protection, observez les mesures de sécurité suivantes lors de l'installation de l'équipement:

- Observez tous les avertissements et consignes indiqués sur l'équipement.
- Assurez-vous que la tension et la fréquence de votre source d'alimentation électrique correspondent à la tension et à la fréquence indiquées sur l'étiquette de la tension électrique nominale du matériel.

- N'insérez en aucun cas un objet quelconque dans les orifices de l'équipement. Des tensions potentiellement dangereuses risquent d'être présentes dans l'équipement. Tout objet étranger conducteur risque de produire un court-circuit pouvant présenter un risque d'incendie ou de décharge électrique, ou susceptible d'endommager le matériel.

Symboles

Les symboles suivants peuvent figurer dans cet ouvrage :



Attention – Vous risquez d'endommager le matériel ou de vous blesser. Observez les consignes indiquées.



Attention – Surface brûlante. Evitez tout contact. Ces surfaces sont brûlantes. Vous risquez de vous blesser si vous les touchez.



Attention – Tensions dangereuses. Pour réduire les risques de décharge électrique et de danger physique, observez les consignes indiquées.



MARCHE – Met le système sous tension alternative.

Selon le type d'interrupteur marche/arrêt dont votre appareil est équipé, l'un des symboles suivants sera utilisé :



ARRET – Met le système hors tension alternative.



VEILLEUSE – L'interrupteur Marche/Veille est sur la position de veille.

Modifications de l'équipement

N'apportez aucune modification mécanique ou électrique à l'équipement. Sun Microsystems décline toute responsabilité quant à la non-conformité éventuelle d'un produit Sun modifié.

Positionnement d'un produit Sun



Attention – N'obstruez ni ne recouvrez les orifices de votre produit Sun. N'installez jamais un produit Sun près d'un radiateur ou d'une source de chaleur. Si vous ne respectez pas ces consignes, votre produit Sun risque de surchauffer et son fonctionnement en sera altéré.



Attention – Le niveau de bruit inhérent à l'environnement de travail, tel qu'il est défini par la norme DIN 45 635 - section 1000, doit être inférieur ou égal à 70Db(A).

Conformité aux normes SELV

Le niveau de sécurité des connexions E/S est conforme aux normes SELV.

Raccordement à la source d'alimentation électrique



Attention – Les produits Sun sont conçus pour fonctionner avec des systèmes d'alimentation électrique monophasés avec prise de terre. Pour réduire les risques de décharge électrique, ne branchez jamais les produits Sun sur une source d'alimentation d'un autre type. Contactez le gérant de votre bâtiment ou un électricien agréé si vous avez le moindre doute quant au type d'alimentation fourni dans votre bâtiment.



Attention – Tous les cordons d'alimentation n'ont pas la même intensité nominale. Les cordons d'alimentation à usage domestique ne sont pas protégés contre les surtensions et ne sont pas conçus pour être utilisés avec des ordinateurs. N'utilisez jamais de cordon d'alimentation à usage domestique avec les produits Sun.



Attention – Votre produit Sun est livré avec un cordon d'alimentation avec raccord à la terre (triphase). Pour réduire les risques de décharge électrique, branchez toujours ce cordon sur une source d'alimentation mise à la terre.

L'avertissement suivant s'applique uniquement aux systèmes équipés d'un interrupteur Veille :



Attention – L'interrupteur d'alimentation de ce produit fonctionne uniquement comme un dispositif de mise en veille. Le cordon d'alimentation constitue le moyen principal de déconnexion de l'alimentation pour le système. Assurez-vous de le brancher dans une prise d'alimentation mise à la terre près du système et facile d'accès. Ne le branchez pas lorsque l'alimentation électrique ne se trouve pas dans le châssis du système.

Pile au lithium



Attention – Sur les cartes UC Sun, une batterie au lithium a été moulée dans l'horloge temps réel, de type SGS n° MK48T59Y, MK48TXXB-XX, MK48T18-XXXPCZ, M48T59W-XXXPCZ ou MK48T08. Cette batterie ne doit pas être remplacée par le client. Elle risque d'exploser en cas de mauvaise manipulation. Ne la jetez pas au feu. Ne la démontez pas et ne tentez pas de la recharger.

Bloc-batterie



Attention – Les unités Sun Fire B10n content load balancing blade contiennent une batterie étanche au plomb. Produits énergétiques portatifs n° TLC02V50. Il existe un risque d'explosion si ce bloc batterie est manipulé ou installé de façon incorrecte. Ne le remplacez que par un bloc batterie Sun Microsystems du même type. Ne le démontez pas et n'essayez pas de le recharger hors du système. Ne le jetez pas au feu. Mettez-le au rebut conformément aux réglementations locales en vigueur.

Couvercle du système

Pour ajouter des cartes, de la mémoire ou des unités de stockage internes, vous devez démonter le couvercle de votre système Sun. N'oubliez pas de le remettre en place avant de mettre le système sous tension.



Attention – Ne travaillez jamais avec un produit Sun dont le couvercle n'est pas installé. Si vous ne respectez pas cette consigne, vous risquez de vous blesser ou d'endommager le système.

Avis de conformité des appareils laser

Les produits Sun faisant appel à la technologie laser sont conformes aux normes de sécurité des appareils laser de classe 1.

Class 1 Laser Product
Luokan 1 Laserlaite
Klasse 1 Laser Apparat
Laser Klasse 1

CD-ROM



Attention – L'utilisation de contrôles et de réglages ou l'application de procédures autres que ceux spécifiés dans le présent document peuvent entraîner une exposition à des radiations dangereuses.

Notice de qualité GOST-R

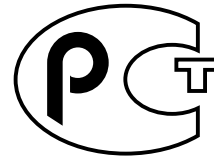

Einhaltung sicherheitsbehördlicher Vorschriften

Lesen Sie diesen Abschnitt sorgfältig durch, bevor Sie mit dem Arbeitsablauf beginnen. Der folgende Text beschreibt Sicherheitsmaßnahmen, die bei der Installation von Sun-Produkten zu beachten sind.

Sicherheitsmaßnahmen

Zu Ihrem eigenen Schutz sollten Sie die folgenden Sicherheitsmaßnahmen bei der Installation befolgen:

- Befolgen Sie alle auf die Geräte aufgedruckten Anweisungen und Warnhinweise.
- Beachten Sie die Geräteaufschrift, um sicherzustellen, daß Netzspannung und -frequenz mit der Gerätespannung und -frequenz übereinstimmen.
- Führen Sie niemals Gegenstände in die Geräteöffnungen ein. Es könnten elektrische Spannungsfelder vorhanden sein. Leitende Fremdkörper können Kurzschlüsse, Feuer und elektrische Schläge verursachen oder Ihr Gerät beschädigen.

Symbole

Die folgenden Symbole werden in diesem Handbuch verwendet:



Achtung – Es besteht die Gefahr der Verletzung und der Beschädigung des Geräts. Befolgen Sie die Anweisungen.



Achtung – Heiße Oberfläche. Vermeiden Sie jede Berührung. Diese Oberflächen sind sehr heiß und können Verbrennungen verursachen.



Achtung – Elektrisches Spannungsfeld vorhanden. Befolgen Sie die Anweisungen, um elektrische Schläge und Verletzungen zu vermeiden.



Ein – Das System wird mit Wechselstrom versorgt.

Abhängig von der Art des Stromschalters Ihres Gerätes wird eventuell eines der folgenden Symbole verwendet:



Aus – Das System wird nicht mehr mit Wechselstrom versorgt.



Wartezustand – (Der Ein-/Standby-Schalter befindet sich in der Standby-Position).

Modifikationen des Geräts

Nehmen Sie keine elektrischen oder mechanischen Gerätemodifikationen vor. Sun Microsystems ist für die Einhaltung der Sicherheitsvorschriften von modifizierten Sun-Produkten nicht haftbar.

Aufstellung von Sun-Geräten



Achtung – Geräteöffnungen Ihres Sun-Produkts dürfen nicht blockiert oder abgedeckt werden. Sun-Geräte sollten niemals in der Nähe von Heizkörpern oder Heißluftklappen aufgestellt werden. Nichtbeachtung dieser Richtlinien können Überhitzung verursachen und die Zuverlässigkeit Ihres Sun-Geräts beeinträchtigen.



Achtung – Der Geräuschpegel, definiert nach DIN 45 635 Part 1000, darf am Arbeitsplatz 70dB(A) nicht überschreiten.

SELV-Richtlinien

Alle Ein-/Ausgänge erfüllen die SELV-Anforderungen.

Netzanschlußkabel



Achtung – Sun-Geräte benötigen ein einphasiges Stromversorgungssystem mit eingebautem Erdleiter. Schließen Sie Sun-Geräte nie an ein anderes Stromversorgungssystem an, um elektrische Schläge zu vermeiden. Falls Sie die Spezifikationen der Gebäudestromversorgung nicht kennen, sollten Sie den Gebäudeverwalter oder einen qualifizierten Elektriker konsultieren.



Achtung – Nicht alle Netzanschlußkabel besitzen die gleiche Stromleitung. Normale Verlängerungskabel besitzen keinen Überspannungsschutz und sind nicht für den Gebrauch mit Computersystemen geeignet. Benutzen Sie keine Haushaltverlängerungskabel für Sun-Geräte.



Achtung – Ihr Sun-Gerät wurde mit einem geerdeten (dreiadrigen) Netzanschlußkabel geliefert. Stecken Sie dieses Kabel immer nur in eine geerdete Netzsteckdose, um Kurzschlüsse zu vermeiden.

Der folgende Hinweis bezieht sich nur auf Geräte mit Standby-Stromschalter:



Achtung – Der Stromschalter dieses Produkts funktioniert nur als Standby-Gerät. Das Netzanschlußkabel dient als Hauptabschaltgerät für das System. Stellen Sie sicher, daß Sie das Netzanschlußkabel in den geerdeten Stromausgang in der Nähe des Systems einstecken. Schließen Sie das Netzanschlußkabel nicht an, wenn die Stromzufuhr vom Systemgehäuse entfernt wurde.

Lithium-Batterie



Achtung – CPU-Karten von Sun verfügen über eine Echtzeituhr mit integrierter Lithiumbatterie, Teile-Nr. MK48T59Y, MK48TXXB-XX, MK48T18-XXXPCZ, M48T59W-XXXPCZ oder MK48T08. Batterien sollten nicht vom Kunden ausgetauscht werden. Sie können bei falscher Handhabung explodieren. Entsorgen Sie die Batterien nicht im Feuer. Entfernen Sie sie nicht und versuchen Sie auch nicht, sie wiederaufzuladen.

Batterien



Achtung – Die Geräte Sun Fire B10n content load balancing blade enthalten auslaufsichere Bleiakumulatoren, Produkt-Nr. TLC02V50 für portable Stromversorgung. Wenn die Batterien nicht richtig gehandhabt oder ausgetauscht werden, besteht Explosionsgefahr. Tauschen Sie Batterien nur gegen Batterien gleichen Typs von Sun Microsystems aus. Versuchen Sie nicht, die Batterien zu entfernen oder außerhalb des Geräts wiederaufzuladen. Entsorgen Sie die Batterien nicht im Feuer. Entsorgen Sie die Batterien ordnungsgemäß entsprechend den vor Ort geltenden Vorschriften.

Abdeckung des Systems

Sie müssen die Abdeckung des Sun-Computersystems entfernen, um Karten, Speicher oder interne Speichergeräte hinzuzufügen. Stellen Sie sicher, daß Sie die Abdeckung wieder einsetzen, bevor Sie den Computer einschalten.



Achtung – Sun-Geräte dürfen nicht ohne Abdeckung in Gebrauch genommen werden. Nichtbeachtung dieses Warnhinweises kann Verletzungen oder Systembeschädigungen zur Folge haben.

Laserrichtlinien

Alle Sun-Produkte, die Lasertechnologie nutzen, erfüllen die Laserrichtlinien der Klasse 1.

Class 1 Laser Product
Luokan 1 Laserlaite
Klasse 1 Laser Apparät
Laser Klasse 1

CD-ROM



Achtung – Die Verwendung von anderen Steuerungen und Einstellungen oder die Durchführung von Arbeitsabläufen, die von den hier beschriebenen abweichen, können gefährliche Strahlungen zur Folge haben.

Verbandsmarke GOST-R

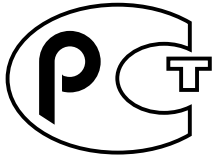

Normativas de seguridad

Lea esta sección antes de llevar a cabo cualquier procedimiento. El texto que aparece a continuación explica las medidas de seguridad que deben tomarse durante la instalación de un producto Sun Microsystems.

Medidas de seguridad

Por su propia seguridad, tome las medidas de seguridad siguientes al instalar el equipo:

- Siga todas los avisos y las instrucciones que aparecen impresas en el equipo.
- Cerciórese de que el voltaje y la frecuencia de la fuente de alimentación coinciden con el voltaje y frecuencia indicados en la etiqueta de clasificación eléctrica del equipo.
- No introduzca objetos de ningún tipo a través de las aberturas del equipo. Dentro pueden darse voltajes peligrosos. Los objetos conductores extraños podrían producir un cortocircuito y, en consecuencia, fuego, descargas eléctricas o daños en el equipo.

Símbolos

Los símbolos siguientes pueden aparecer en este manual:



Precaución – Existe el riesgo de que se produzcan lesiones personales y daños en el equipo. Siga las instrucciones.



Precaución – Superficie caliente. Evite todo contacto. Las superficies están calientes y pueden causar lesiones personales si se tocan.



Precaución – Riesgo de voltajes peligrosos. Para reducir el riesgo de descargas eléctricas y de daños en la salud de las personas, siga las instrucciones.



Encendido – Proporciona alimentación de CA al sistema.

Según el tipo de interruptor de alimentación del que disponga el dispositivo, se utilizará uno de los símbolos siguientes:



Apagado – Corta la alimentación de CA del sistema.



Espera – El interruptor de encendido/espera está en la posición de espera.

Modificaciones en el equipo

No realice modificaciones mecánicas ni eléctricas en el equipo. Sun Microsystems no se hará responsable del cumplimiento de las normas en el caso de un producto Sun que ha sido modificado.

Lugar y colocación de un producto Sun



Precaución – No obstruya ni tape las rejillas del producto Sun. Nunca coloque un producto Sun cerca de radiadores o fuentes de calor. El incumplimiento de estas directrices puede causar un recalentamiento y repercutir en la fiabilidad del producto Sun.



Precaución – El nivel de ruido en el lugar de trabajo, definido en el apartado 1000 de DIN 45 635, debe ser 70 Db (A) o inferior.

Cumplimiento de las normas SELV

Las condiciones de seguridad de las conexiones de E/S cumplen las normas SELV.

Conexión del cable de alimentación



Precaución – Los productos Sun han sido diseñados para funcionar con sistemas de alimentación monofásicos que tengan un conductor neutral a tierra. Para reducir el riesgo de descargas eléctricas, no enchufe ningún producto Sun a otro tipo de sistema de alimentación. Si no está seguro del tipo de alimentación del que se dispone en el edificio, póngase en contacto con el encargado de las instalaciones o con un electricista calificado.



Precaución – No todos los cables de alimentación tienen la misma clasificación de corriente. Los cables de prolongación domésticos no ofrecen protección frente a sobrecargas y no están diseñados para ser utilizados con sistemas informáticos. No utilice cables de prolongación domésticos con el producto Sun.



Precaución – El producto Sun se suministra con un cable de alimentación (de tres hilos) con conexión a tierra. Para reducir el riesgo de descargas eléctricas, enchufe siempre el cable a una toma de corriente con conexión a tierra.

La precaución siguiente sólo se aplica a aquellos dispositivos que posean un interruptor de alimentación de espera:



Precaución – El interruptor de alimentación del producto funciona como dispositivo de espera solamente. El cable de alimentación actúa como el dispositivo de desconexión primario del sistema. Cerciérese de enchufar el cable de alimentación a una toma de corriente con conexión a tierra situada cerca del sistema y a la que se pueda acceder con facilidad. No conecte el cable de alimentación cuando se haya quitado la fuente de alimentación del bastidor del sistema.

Batería de litio



Precaución – En la placa CPU de los productos Sun, hay una batería de litio incorporada en el reloj en tiempo real, SGS núm. MK48T59Y, MK48TXXB-XX, MK48T18-XXXPCZ, M48T59W-XXXPCZ o MK48T08. Los usuarios no deben cambiar las baterías. Podrían estallar si no se utilizan adecuadamente. No arroje la batería al fuego. No la desmonte ni intente recargarla.

Paquete de baterías



Precaución – Las unidades Sun Fire B10n content load balancing blade contienen una batería de plomo sellada, Productos eléctricos portátiles núm. TLC02V50. Existe el riesgo de explosión si el paquete de baterías no se utiliza correctamente o se sustituye de forma incorrecta. Sustitúyalo sólo por el mismo tipo de paquete de baterías de Sun Microsystems. No lo desmonte o intente recargarlo fuera del sistema. No arroje la batería al fuego. Deshágase de las baterías correctamente siguiendo las normas locales vigentes.

Cubierta de la unidad del sistema

Debe retirar la cubierta de la unidad del sistema informático Sun para añadir tarjetas, memoria o dispositivos de almacenamiento internos. Asegúrese de volver a colocar la cubierta superior antes de encender el equipo.



Precaución – No ponga en funcionamiento los productos Sun sin que la cubierta superior se encuentre instalada. De lo contrario, podrían producirse lesiones personales o daños en el sistema.

Aviso de cumplimiento de las normas para láser

Los productos Sun que utilizan tecnología láser cumplen los requisitos para láser de Clase 1.

Class 1 Laser Product
Luokan 1 Laserlaite
Klasse 1 Laser Apparat
Laser Klasse 1

CD-ROM



Precaución – La utilización de controles, ajustes o la realización de los procedimientos distintos a los especificados en el presente documento podrían provocar la exposición a radiaciones peligrosas.

Certificación GOST-R

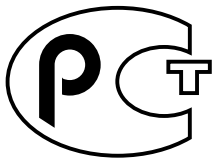

Nordic Lithium Battery Cautions

Norge



ADVARSEL – Litiumbatteri –
Eksplosjonsfare. Ved utskifting benyttes kun
batteri som anbefalt av apparatfabrikanten.
Brukt batteri returneres apparatleverandøren.

Sverige



VARNING – Explosionsfara vid felaktigt
batteribyte. Använd samma batterityp eller en
ekvivalent typ som rekommenderas av
apparatillverkaren. Kassera använt batteri
enligt fabrikantens instruktion.

Danmark



ADVARSEL! – Litiumbatteri –
Eksplosionsfare ved fejlagtig håndtering.
Udskiftning må kun ske med batteri af samme
fabrikat og type. Levér det brugte batteri
tilbage til leverandøren.

Suomi



VAROITUS – Paristo voi räjähtää, jos se on
virheellisesti asennettu. Vaihda paristo
ainoastaan laitevalmistajan suosittelemaan
tyyppiin. Hävitä käytetty paristo valmistajan
ohjeiden mukaisesti.

Declaration of Conformity

Compliance Model Number: Compliance ID
Product Family Name: Sun Fire B10n content load balancing blade

EMC

USA - FCC Class A

This equipment complies with Part 15 of the FCC Rules. Operation is subject to the following two conditions:

- 1) This equipment may not cause harmful interference.
- 2) This equipment must accept any interference that may cause undesired operation.

European Union

This equipment complies with the following requirements of the EMC Directive 89/336/EEC:

As Telecommunication Network Equipment (TNE) in both Telecom Centers and Other Than Telecom Centers per (as applicable):

EN300-386 V.1.3.1 (09-2001) Required Limits:

EN55022/CISPR22	Class A
EN61000-3-2	Pass
EN61000-3-3	Pass
EN61000-4-2	6kV (Direct), 8 kV (Air)
EN61000-4-3	3 V/m 80-1000MHz, 10 V/m 800-960 MHz and 1400-2000 MHz
EN61000-4-4	1 kV AC and DC Power Lines, 0.5 kV Signal Lines
EN61000-4-5	2 kV AC Line-Gnd, 1 kV AC Line-Line and Outdoor Signal Lines, 0.5 kV Indoor Signal Lines > 10m.
EN61000-4-6	3 V
EN61000-4-11	Pass

As information Technology Equipment (ITE) Class A per (as applicable):

EN55022:1998/CISPR22:1997	Class A
EN55024:1998 Required Limits:	
EN61000-4-2	4 kV (Direct), 8 kV (Air)
EN61000-4-3	3 V/m
EN61000-4-4	1 kV AC Power Lines, 0.5 kV Signal and DC Power Lines
EN61000-4-5	1 kV AC Line-Line and Outdoor Signal Lines
	2 kV AC Line-Gnd, 0.5 kV DC Power Lines
EN61000-4-6	3 V
EN61000-4-8	1 A/m
EN61000-4-11	Pass
EN61000-3-2:1995 + A1, A2, A14	Pass
EN61000-3-3:1995	Pass

Safety

This equipment complies with the following requirements of the Low Voltage Directive 73/23/EEC:

EC Type Examination Certificates:

EN60950:1992, 2nd Edition, Amendments 1, 2, 3, 4, 11	TÜV Rheinland Certificate No. xxxxxxxxxxxx
IEC 950:1991, 2nd Edition, Amendments 1, 2, 3, 4	CB Scheme Certificate No. xxxxxxxxxxxx
Evaluated to all CB Countries	
FDA DHHS Accession Number (Monitors Only)	

Supplementary Information: This product was tested and complies with all the requirements for the CE Mark.

/S/

Dennis P. Symanski
Manager, Compliance Engineering
Sun Microsystems, Inc.
901 San Antonio Road, MPK15-102
Palo Alto, CA 94303-4900 U.S.A.
Tel: 650-786-3255
Fax: 650-786-3723

DATE

/S/

Peter Arkless
Quality Manager
Sun Microsystems Scotland, Limited
Springfield, Linlithgow
West Lothian, EH49 7LR
Scotland, United Kingdom
Tel: 0506-670000 Fax: 0506-760011

DATE

Contents

- 1. Product Overview 1**
 - Hardware and Software Overview 1
 - Software Architecture 2
 - Hardware and Software Requirements 3
 - Product Features 3
 - Key Features 3
 - Server Selection Algorithms 4
 - Supported Protocols 4
 - Diagnostic Support 4
 - The Role of the Content Load Balancing Blade 4
 - Topology Fundamentals 8
 - The Role of the B10p SSL Proxy Blade 10
 - Failover Alternatives 11
 - The Role of VLANs 12
 - System Integration 13
 - Usage Overview 13
 - Command Modes 13
- 2. Installing the Blade and Setting Up the System 15**
 - Installing the Hardware 15

▼ To Install the Hardware	15
LED Displays	19
Location of Ports	20
Connecting to the 10/100/1000BASE-T Data Network Ports	22
Serial Port Pin Numbers	23
Powering On Content Load Balancing Blades	24
Powering Off Content Load Balancing Blades	26
Powering Off With an Orderly Shutdown of the Operating System	26
Forcing the Power Off	27
Powering Off a Load Balancing Blade Without Requiring the Confirmation Prompt	27
Powering a Load Balancing Blade Down to Standby Mode to Save Power	27
Powering Off a Content Load Balancing Blade to Remove It	28
3. Preparing the Sun Fire B10n Content Load Balancing Blade for Load Balancing	29
Configuring the Blade Servers	29
▼ To Check the Blade Server Module Software Version	30
▼ To Set Up the Blade Server	30
Setting Up the Load Balancing Blade	33
▼ To Set Up a Content Load Balancing Blade	33
Completing the Basic Configuration	36
▼ To Configure a Default Gateway	36
▼ To Configure the DNS Server	36
▼ To Configure DNS Suffix	36
▼ To Commit the Configuration	36
▼ To Verify the Configuration	37
4. Command-Line Options	39

Typographic Conventions Specific to the Sun Fire B10n Command Line Interface 39

User Access 40

Using the `login` Command 41

▼ To Log In as Administrator 41

Adding Users 42

▼ To Add a User 42

▼ To Change the User Access Level 43

▼ To Change the User Password 43

▼ To Remove a User 43

▼ To List All Users 43

Configuring the Networking 44

▼ To Configure the Management IP Address 44

▼ To Send a `ping` Request 45

▼ To Unconfigure a Network Interface 46

▼ To Configure a DNS Server 46

▼ To Remove a DNS Server 47

▼ To Configure the DNS Suffix 47

▼ To Show DNS Use 47

▼ To Unconfigure the DNS Suffix 47

▼ To Configure the Default Gateway 48

▼ To Unconfigure the Default Gateway 48

▼ To Set the Default Hostname 48

▼ To Show the Network Configurations 49

▼ To Show ARP Entries 49

To Configure the Subnet Mask for a VIP 50

▼ To List the VIPs Configured 50

Monitoring 50

▼ To Set Up Server Monitoring 51

Configuring SSL Blade Entries	51
▼ To Add an SSL Blade	52
▼ To Remove an SSL Blade	52
▼ To Add a Port Pair to an SSL Blade Entry	53
▼ To Remove a Port Pair from an SSL Blade Entry	53
▼ To Add an Interface to an SSL Blade Entry	54
▼ To Remove an Interface from an SSL Blade Entry	54
▼ To Enable an SSL Blade Entry	55
▼ To Disable an SSL Blade Entry	55
▼ To Show the Configured SSL Blades	55
Configuring the Content Load Balancing Blade	56
▼ To Set the TCP Parameters	56
▼ To Set Parameters for TCP Connection Handoff	58
▼ To Show All the Default TCP Parameters Settings	58
Load Balancing Service Configuration and Management	59
Creating a Load Balancing Service	59
▼ To Create a Load Balancing Service	59
▼ To Add SSL Devices to a Service	61
▼ To Remove SSL Devices from a Service	62
▼ To Set SSL Devices in a Service as Active or Standby	63
▼ To Add a Default Load Balancing Group to a Load Balancing Service	63
▼ To Set the TCP Parameters for a Service	65
▼ To Set Parameters for TCP Connection Handoff for a Service	67
▼ To Add a Service Point to a Service	68
▼ To Remove a Service Point From a Service	69
▼ To Configure a Service for Client IP or Subnet-Based Persistence	70
▼ To Remove Client IP or Subnet Based Persistence from a Service	72
Configuring a Service for Service Point Tracking	72

- ▼ To Configure a Service for Service Point Tracking 73
- ▼ To Remove Tracking Service Point from a Service 74
- ▼ To Configure a Service for Cookie-Based Persistence 75
- ▼ To Remove Cookie Persistence From a Service 76
- ▼ To Enable a Load Balancing Service 77
- ▼ To Disable a Load Balancing Service 77
- ▼ To Remove a Load Balancing Service 78

Server Configuration 78

- ▼ To Enable a Server 78
- ▼ To Disable a Server 79

Load Balancing Rule Configuration 80

Creating an IP Load Balancing Rule 80

- ▼ To Create an IP Load Balancing Rule 81

Creating an HTTP Load Balancing Rule 82

- ▼ To Create an HTTP Load Balancing Rule 82
- ▼ To Remove a Load Balancing Rule 83
- ▼ To Build Load Balancing Rules 84
- ▼ To Get the Status for the Build for Load Balancing Rules 84
- ▼ To Get the Status for the Last Build for Load Balancing Rules 85
- ▼ To Stop the Build for Load Balancing Rules 85

Load Balancing Group Configuration and Management 85

- ▼ To Create a Default Load Balancing Group 85
- ▼ To Create a Load Balancing Group 86
- ▼ To Add Rules to a Load Balancing Group 88
- ▼ To Remove Rules From a Load Balancing Group 89
- ▼ To Add Servers to a Load Balancing Group 90
- ▼ To Remove Servers From a Load Balancing Group 91
- ▼ To Set Servers for a Load Balancing Group as Active or Standby 92

- ▼ To Remove Load Balancing Groups 93
- Load Balancing Configuration Listings 94
 - ▼ To List Load Balancing Services 94
 - ▼ To List Load Balancing Rules 95
 - ▼ To List Load Balancing Groups 96
 - ▼ To List All Servers in the System 97
- Configuring the System 97
 - ▼ To Configure the Image for the Next Reboot 97
 - ▼ To Download a New Boot Image Over the Network 98
 - ▼ To Configure the Diagnostics Level 99
 - ▼ To Configure the Debug Level for Specific Modules 99
 - ▼ To Shutdown the System 101
 - ▼ To Reboot the System 101
 - ▼ To Show the Date and Time 102
 - ▼ To Show the System Settings on the B10n 102
 - ▼ To Show the System Uptime 102
 - ▼ To Show Memory 103
 - ▼ To Show Modules 103
 - ▼ To Export a Configuration to a Remote Host 106
 - ▼ To Import a Configuration From a Remote Host 106
 - ▼ To Commit the Current Configuration 106
 - ▼ To Show the Current Saved Configuration 107
 - ▼ To Remove the Current Configuration in Flash 107
 - ▼ To Specify the Configuration in Flash to Use after a System Reboot 107
- Flash File System Commands 108
 - ▼ To Output a File to the Screen 108
 - ▼ To Change the Current Directory 108
 - ▼ To Copy a File 109

- ▼ To Rename a File 109
- ▼ To Delete a File 109
- ▼ To Create a New Directory 109
- ▼ To Remove a Directory 109
- ▼ To List Files 110
- ▼ To Print the Current Working Directory 110
- ▼ To Compress All Files in a Directory 110
- ▼ To Uncompress Files 110
- ▼ To Display Contents of a Compressed File 111

Other Useful Commands 111

- ▼ To Clear the Screen 111
- ▼ To Create an Alias for Any Command 111
- ▼ To Send a Message to All Logged-on Users 112
- ▼ To Echo a String on the Screen 112
- ▼ To View the Command-Line Interface Tree 112
- ▼ To Print the History of All Executed Commands 119
- ▼ To Get Help for CLI Commands 120
- ▼ To Logout 120
- ▼ To Exit From a Script 120
- ▼ To Retrieve the Current User Information 120
- ▼ To Retrieve Information About All Users 121
- ▼ To Display Console Settings 121
- ▼ To Turn On Hardwrap on the Console 121

5. Configuring VLAN Parameters 123

Available VLAN Types 123

Enabling VLAN Tagging 124

- ▼ To Set Client Traffic VLAN Tag 124
- ▼ To Enable VLAN Tagging 125

- ▼ To Set Management VLAN 125
- ▼ To Set VLAN for Service 126
- ▼ To Enable VLAN Tagging for a Service 126
- ▼ To Disable VLAN Tagging for a Service 127
- ▼ To Show VLANs 128
- Disabling VLAN Tagging 128
- 6. Updating the Application Software and the BSC Firmware 131**
 - Introduction 131
 - Setting up a TFTP Server 132
 - Software Architecture 133
 - Updating the B10n Software 135
 - Updating the BSC Firmware 136
 - ▼ To Update the Software Interactively 137
 - ▼ To Update the Software Noninteractively 138
 - Choosing the Boot Image 139
 - ▼ To Specify and Make the Boot Image Permanent 139
 - ▼ To Specify the Boot Image at Boot Time 139
- A. Diagnostics and Troubleshooting 141**
 - Diagnostic Tools 141
 - NPU POST and SDRAM Diagnostic Tests 142
 - Image Management and Troubleshooting 147
 - The Boot Process 147
 - Setting the Diagnostic Level 150
 - ▼ To Set the Diagnostic Level 150
- B. Tutorial and Examples 151**
 - Configuring Layer 4 and Layer 7 Load Balancing 151
 - Setting the Networking Configurations 151

▼ To Configure the IP Addresses	151
▼ To Configure the Default Gateway	152
▼ To Configure the DNS Server	152
▼ To Configure DNS Suffix	152
Configuring a Basic Layer 4 Service Without Any Rules	152
▼ To Create a Layer 4 Service	152
▼ To Add Two blade servers to the Default Load Balancing Group for the Service	153
▼ To Add Another Server to the Default Load Balancing Group	154
▼ To Remove a Server From the Default Load Balancing Group	154
Configuring a Basic Layer 4 Service With Rules	155
▼ To Configure a Layer 4 Service with Layer 4 (IP) Rule	155
Configuring a Basic Layer 7 Service	157
▼ To Configure a Basic Layer 7 Service Without Rules	157
▼ To Configure a Layer 7 Service with Layer 7 Rules	157
▼ To Configure a Service for IP Persistence	161
▼ To Remove IP Persistence From a Service	161
▼ To Configure a Service for Tracking	161
▼ To Remove Port Tracking	162
▼ To Add an End Point Tracking to a Service	162
▼ To Remove End Point Tracking	163
▼ To Configure a Service for Cookie-Based Persistence	163
▼ To Remove Cookie Persistence from a Service	164
▼ To Configure a UDP Service	164
▼ To Configure an FTP Service	165
▼ To Add an End Point to a Service to make it Multi-homed	166
Setting Up VLAN	167
Set Up on the Switch	167
▼ To Set Up VLAN on the Server	167

▼ To Set Up VLAN on a Load Balancing Blade 169

C. Alphabetical Command Reference 171

A 171

B 171

C 171

D 172

E 173

F 173

H 173

I 174

L 174

M 174

N 175

P 175

R 176

S 176

T 178

U 178

V 179

W 179

Figures

- FIGURE 1-1 Ethernet Ports and Interfaces on the B1600 System Chassis and their Default VLAN Numbers 6
- FIGURE 1-2 A Dedicated Management Network and Web Server Network Isolated from the Backend Network 7
- FIGURE 1-3 Sample Topology: Dual Tree Using External and Internal Switches 10
- FIGURE 2-1 The Filler Panel Locking Mechanism 16
- FIGURE 2-2 Disengaging the Blade-Locking Mechanism 16
- FIGURE 2-3 Removing the Filler Panel 17
- FIGURE 2-4 Blade Locking Mechanism 17
- FIGURE 2-5 Aligning and Inserting the Blade 18
- FIGURE 2-6 Closing the Blade Lever Mechanism 19
- FIGURE 2-7 External Cable Connections 21
- FIGURE 2-8 The 10/100/1000BASE-T Data Network Ports 22
- FIGURE 2-9 Serial Port Pin Numbers 23

Tables

TABLE 1-1	Hardware and Software Requirements	3
TABLE 2-1	Blade and Power Supply Status Codes	20
TABLE 2-2	10/100/1000BASE-T Data Network Port Pinouts	22
TABLE 2-3	Serial Port Pinouts	23
TABLE 4-1	user Commands	40
TABLE 4-2	Parameter Description for User Access	42
TABLE 4-3	Parameters for Setting the IP Address	44
TABLE 4-4	Variables for Sending a ping Request	46
TABLE 4-5	Parameters for Configuring the Subnet Mask for a VIP	50
TABLE 4-6	Parameters and Variables for Setting Up a Server for Monitoring	51
TABLE 4-7	Variables for Adding SSL Blade Configurations	52
TABLE 4-8	Parameters for Adding and Removing Port Pairs	53
TABLE 4-9	Variables for Adding or Removing an SSL Blade Interface	54
TABLE 4-10	Options for Setting the TCP Parameters	57
TABLE 4-11	Parameters for Creating a Load Balancing Service	60
TABLE 4-12	Parameters for Adding SSL Devices to a Service	62
TABLE 4-13	Parameters for Removing SSL Devices from a Service	62
TABLE 4-14	Parameters for Modifying SSL Devices in a Service	63
TABLE 4-15	Parameters for Adding a Default Load Balancing Group to a Service	64
TABLE 4-16	TCP, Parameters for a Service	66

TABLE 4-17	Service Point Parameters	68
TABLE 4-18	Service Point Parameters	69
TABLE 4-19	Parameters for Configuring a Service for Persistence	71
TABLE 4-20	Parameters for Configuring a Service for Tracking	73
TABLE 4-21	Parameters for Configuring a Service for Cookie-Based Persistence	75
TABLE 4-22	Parameters for Enabling or Disabling a Server	79
TABLE 4-23	Parameters for Creating an IP Load Balancing Rule	81
TABLE 4-24	Parameters for Creating an HTTP Load Balancing Rule	82
TABLE 4-25	Parameters for Creating Load Balancing Groups	87
TABLE 4-26	Parameters for Adding Rules to a Load Balancing Group	89
TABLE 4-27	Parameters for Adding Servers to a LB Group	90
TABLE 4-28	Parameters for Removing Servers to a LB Group	91
TABLE 4-29	Parameters for Setting Servers to Active or Standby	92
TABLE 4-30	Parameters for Configuring the Diagnostic and Verbosity Level	99
TABLE 4-31	Parameters for Configuring the Debug Level for Specific Modules	100
TABLE 4-32	Module Names to Use for Configuring the Debug Level	100
TABLE 4-33	Parameters for the <code>dump memory</code> Command	103
TABLE 4-34	Parameters for the <code>dump module</code> Command	104
TABLE 4-35	Module Names to Use with the <code>dump module</code> Command	104
TABLE 4-36	Modules in the NPU Listed by Index	104
TABLE 5-1	Parameters for the <code>no enable vlan</code> Command	129

Preface

The Sun Fire B10n Content Load Balancing Blade Administration Guide provides installation and configuration instructions for the Sun Fire™ content load balancing blade. These instructions are designed for an experienced system administrator with networking knowledge.

How This Book Is Organized

Chapter 1 describes the product hardware and software and lists hardware and software requirements and features.

Chapter 2 describes how to install the hardware.

Chapter 3 describes the procedures for preparing the blade for load balancing.

Chapter 4 describes the management and control interfaces available through the Sun Fire B10n content load balancing blade command line interface (CLI). The chapter lists the CLI commands under the various management categories with the appropriate parameters.

Chapter 5 describes how to configure the VLAN parameters.

Chapter 6 describes how to download and install firmware upgrades. The chapter includes the URL for upgrades

Appendix A contains an overview of the diagnostic tools and instructions for using them. There is also a section outlining some common troubleshooting issues.

Appendix B provides a tutorial for configuring the product, including examples.

Appendix C provides an alphabetical listing of all the commands for the Sun Fire B10n content load balancing blade.

Using UNIX Commands

This document might not contain information on basic UNIX® commands and procedures such as shutting down the system, booting the system, and configuring devices.

See the following for this information:

- Software documentation that you received with your system
- Solaris™ operating environment documentation, which is at <http://docs.sun.com>

Typographic Conventions

Typeface*	Meaning	Examples
AaBbCc123	The names of commands, files, and directories; on-screen computer output	Edit your <code>.login</code> file. Use <code>ls -a</code> to list all files. % You have mail.
AaBbCc123	What you type, when contrasted with on-screen computer output	% su Password:
<i>AaBbCc123</i>	Book titles, new words or terms, words to be emphasized. Replace command-line variables with real names or values.	Read Chapter 6 in the <i>User's Guide</i> . These are called <i>class</i> options. To delete a file, type <code>rm filename</code> .

* The settings on your browser might differ from these settings.

Shell Prompts

Shell	Prompt
C shell	<i>machine-name%</i>
C shell superuser	<i>machine-name#</i>
Bourne shell and Korn shell	\$
Bourne shell and Korn shell superuser	#

Related Documentation

Application	Title	Part Number
Installation	<i>Sun Fire™ B1600 Blade System Chassis Hardware Installation Guide</i>	816-7614-10
Software setup	<i>Sun Fire B1600 Blade System Chassis Software Setup Guide</i>	816-3361-10
Safety and compliance	<i>Sun Fire B1600 Blade System Chassis Safety and Compliance Manual</i>	816-3364-10

Accessing Sun Documentation

You can view, print, or purchase a broad selection of Sun documentation, including localized versions, at:

<http://www.sun.com/documentation>

Contacting Sun Technical Support

If you have technical questions about this product that are not answered in this document, go to:

<http://www.sun.com/service/contacting>

Sun Welcomes Your Comments

Sun is interested in improving its documentation and welcomes your comments and suggestions. You can submit your comments by going to:

<http://www.sun.com/hwdocs/feedback>

Please include the title and part number of your document with your feedback:

Sun Fire B10n Content Load Balancing Blade Administration Guide, part number 817-0627-10

Product Overview

This chapter describes the Sun Fire B10n content load balancing blade hardware and software and lists both its features and the requirements for using it.

This chapter contains the following sections:

- “Hardware and Software Overview” on page 1
- “Software Architecture” on page 2
- “Hardware and Software Requirements” on page 3
- “Product Features” on page 3
- “The Role of the Content Load Balancing Blade” on page 4
- “System Integration” on page 13
- “Usage Overview” on page 13

Hardware and Software Overview

The Sun Fire B10n content load balancing blade is a networking product that provides content load balancing for Sun’s blade-based servers and other horizontally scaled Sun platforms. It is designed to work in the management framework of the Sun Fire™ B1600 blade system chassis. As part of the Sun Fire B1600 blade system chassis, the Sun Fire B10n content load balancing blade connects to the Sun Fire B1600 blade system chassis midplane through two Gigabit Ethernet interfaces. The blade offers Layer 4 through Layer 7 load balancing. The server decision can be based on IP protocol and TCP/UDP ports (Layer 4) or URLs, cookies, and CGI scripts (Layer 7). Both these functions can operate up to the two Gigabit full-duplex line rate.

The Sun Fire B10n content load balancing blade implements hardware assisted triangular load balancing, which enables the switch capacity to be used for aggregate responses rather than individual link capacity to the blade. To enable

triangular data flow, you must install the application software on each Sun Fire B10n content load balancing blade and the blade server module on each Sun Fire B100s blade server.

From a logical perspective, the following components make up a Sun Fire B10n content load balancing blade:

- A Layer 4 parsing, classification, and forwarding engine.
- A Layer 7 content classifier that parses the request packet and matches the URL, CGI script, or cookies. This unit also performs the TCP 3-way handshake, makes the load balancing decision, and hands the connection off to the server.
- Management software to set up and maintain service entry points, load balancing groups, and Layer 7 rule tables.

Software Architecture

The Sun Fire B10n content load balancing blade provides optimized server to client response. To support this response and provide tight communications between the content load balancing blade and the B1600 blade servers a software module must be installed on each of these servers. This software module is referred to as the Blade Server Module and is loaded using the Solaris package add process.

The content load balancing blade is based on specialized hardware including a general purpose microprocessor that runs a real time operating system. The code that runs on this processor is called the Application Software and can be updated using a TFTP process.

In addition to the general purpose processor there is a micro controller called the Blade Support Controller (BSC). The BSC is the primary interface to the Sun Fire B1600 Service Controllers (SC) and performs the Advanced Lights-out Management (ALOM) function for a given blade. These functions include powering on and off of the blades as well as monitoring functions. This is referred to as the BSC Firmware and can be updated using the “flashupdate” command which involves using TFTP.

The Sun Fire B10n software components:

- Blade server module
- B10n application software
- BSC firmware

Check the following web site to ensure you have the latest Sun Fire B10n software:

<http://www.sun.com/software/download/network.html>

The B10n has the capability to hold two versions of the Application Software and a diagnostic image. This allows a new image to be loaded without overwriting the active image. The blade must be rebooted to activate an image. See “Choosing the Boot Image” on page 139.

The B10n specialized hardware includes a rule based classification engine. The rules are entered through the command line interface and then compiled using a build process. See “Creating an HTTP Load Balancing Rule” on page 82.

Hardware and Software Requirements

Before using the Sun Fire B10n content load balancing blade, make sure your system meets the following hardware and software requirements:

TABLE 1-1 Hardware and Software Requirements

Hardware and Software	Requirement
Hardware	<ul style="list-style-type: none">• Sun Fire™ B1600 blade system chassis and other horizontally scaled Sun platforms• Sun Fire B100s blade server
Software	<ul style="list-style-type: none">• Sun Fire B100s blade server Solaris 8 HW 3/03 or HW 7/03 operating environment• Sun Fire B1600 SC 1.1.3 or subsequent compatible system controller firmware

Product Features

Key Features

- Two full-duplex Gigabit Ethernet interfaces
- Content load balancing based on URL, Cookies, or CGI scripts
- Server to client direct response
- Persistence
- 500 Layer4 through Layer 7 rules
- Server, path, and blade failover
- Integrated management with the Sun Fire B1600 blade system chassis, the Sun blade servers, and SSL proxy blades

Server Selection Algorithms

- Round robin
- Weighted round robin
- Static

Supported Protocols

The Sun Fire B10n content load balancing blade uses the following protocols for its services or management functions:

- TCP
- UDP
- HTTP
- FTP
- TFTP
- ICMP
- ARP
- DNS
- Telnet

Diagnostic Support

- User executable self-test
- Power on self-test (POST)
- Manually invoked tests
- Error logging routines
- Debugging commands

The Role of the Content Load Balancing Blade

The Sun Fire B10n content load balancing blade is a component within a larger system ultimately delivering highly available web services to a client population over an IP-based network. This section describes the role of such a highly integrated content load balancer within the larger system.

The minimal set of components comprising the system encompasses:

- One or more Sun Fire B1600 blade system chassis

- One or more Sun Fire B10n content load balancing blades
- One or two Switch and System Controller (SSC) units per system chassis
- One or more servers. Servers can be any mix of blade servers housed in B1600 blade system chassis and stand-alone Sun servers external to the chassis but connected to the same Ethernet broadcast domain (Layer 2 network)

Additionally, the system may have:

- One or more Sun Fire B10p SSL proxy blades
- External distribution switches extending one or more of the networks
- Additional servers providing content, local name and configuration services, and aggregate management for one or multiple shelves. These servers may participate in the overall system by supporting various TFTP, NFS, DHCP, DNS, and N1 deployment related functions

In general terms, the intra-shelf network topology formed by connecting the Sun Fire B1600 system components is either a single or a dual redundant Layer 2 topology with blades “one-arm” connected to each of the switch fabrics. The switch fabric is VLAN partitionable for strict traffic isolation. SSC switches and uplinks can be used for a simple inter-shelf network, or connected to external distribution switches for larger configurations.

Note – This section defines the generic features and functions of the Sun Fire B10n content load balancing blade. For more information about a specific firmware release, refer to the *Sun Fire B10n Content Load Balancing Blade Release Notes*.

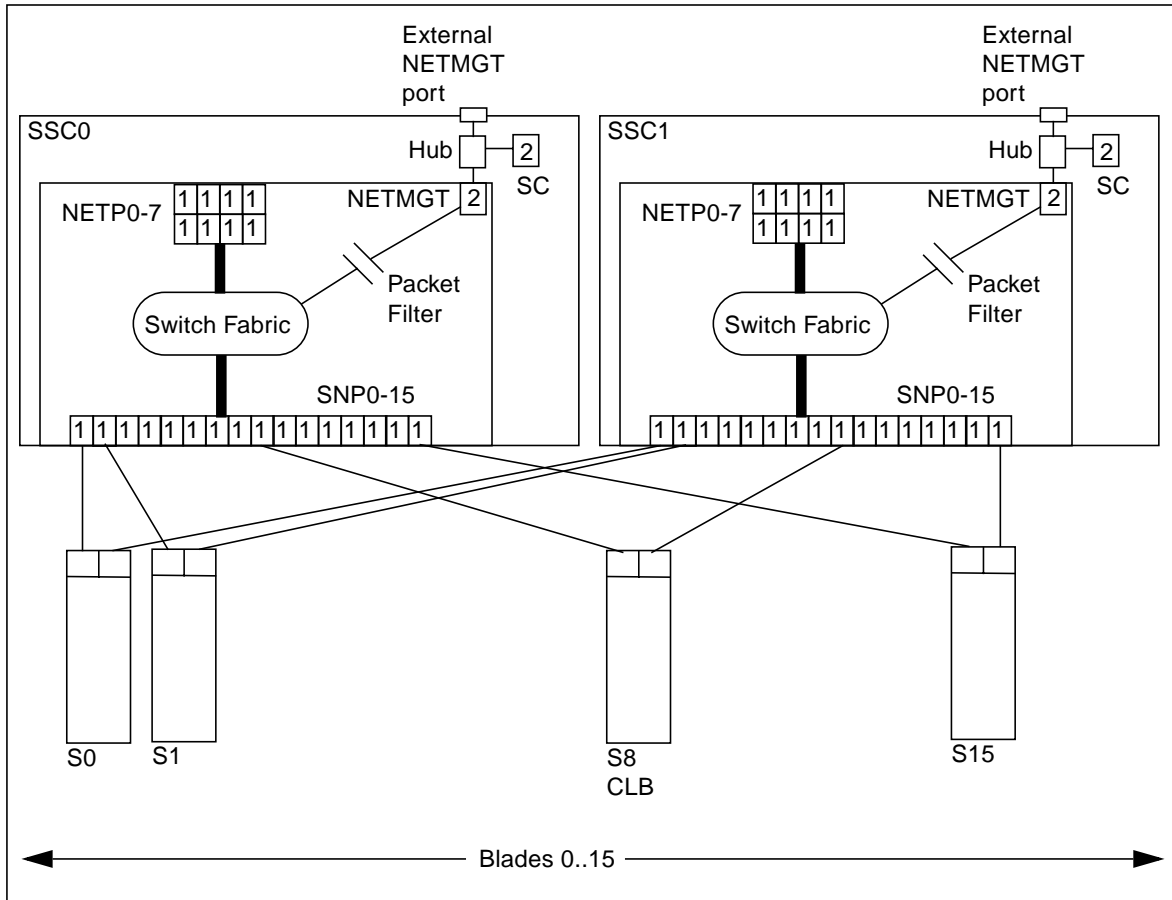

FIGURE 1-1 Ethernet Ports and Interfaces on the B1600 System Chassis and their Default VLAN Numbers

FIGURE 1-1 shows the intra-shelf network, where a Sun Fire B10n content load balancing blade (shown in slot S8) can reside in any slot (S0 through S15) and connect to both SSC0 and SSC1 switch fabrics. The uplinks are labeled NETP0 through NETP7.

The numerals associated with each port (either 1 or 2), represent the VLAN numbers programmed into the system by default. The numbers indicate that there is one data VLAN (1), and one management VLAN (2). Further VLAN partitioning might be desirable as shown in FIGURE 1-2. The actual VLAN-ID assignment can be coordinated with the VLANs used in the external switches, or its scope can be limited to the internal switches, by keeping the uplinks as untagged VLANs.

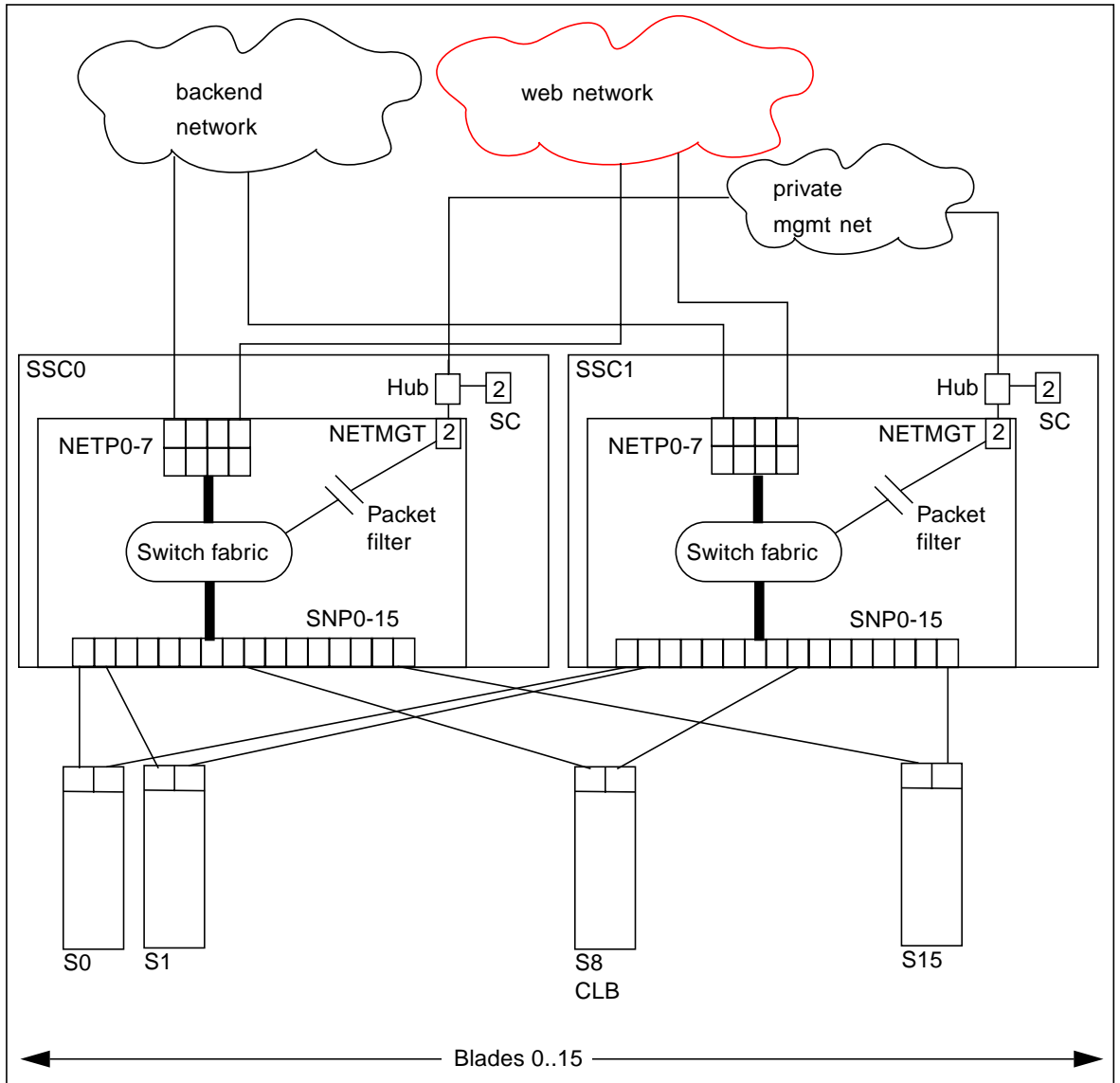

FIGURE 1-2 A Dedicated Management Network and Web Server Network Isolated from the Backend Network

The role of the content load balancer is to present a set of highly available network services. These services can be transported over http, TCP, or UDP, and are addressable through one or more Virtual IP addresses (VIPs), that the content load balancer is responsible for:

- Providing one level of address indirection so that the number and nature of actual servers can transparently evolve over time.
- Dividing requests among servers grouped in load balancing groups so that the total service demand can be satisfied through horizontal scaling.
- Maintaining persistence for clients or groups of clients requesting services that require affinity, that is, services where multiple consecutive requests must be satisfied by the same server.
- Delivering highly available services by taking responsibility for the failover functions that alter network paths, servers, and load balancer pairs upon service failure detection.
- Associating VIPs to VLAN-based partitions are based on meaningful criteria (service owner, back-end network, and the like).
- Participating one or more SSL proxy blades in the request packet flow whenever SSL decryption is necessary.

VIPs are the routable IP addresses that clients obtain for the service through DNS lookups. A VIP address is “owned” by one content load balancer at a given time. VIPs are preserved through the content load balancer all the way to servers. Requests are directed to servers by re-writing their MAC addresses and their VLAN tags (and optionally the TCP/UDP port values).

A service is identified by a 3-tuple comprising the VIP, the Layer 4 protocol value (TCP or UDP), and TCP/UDP destination port. A multi-homed service can be associated with more than one 3-tuple.

Topology Fundamentals

To match the ample switching capacity of the SSC units in the Sun Fire B1600 Blade System the content load balancer solution is designed to direct server responses toward clients without passing through the content load balancer. This enables the outbound capacity of the system to scale in proportion to the number of servers deployed, and to exploit the natural web traffic asymmetry where most of the traffic is server outbound.

To combine the uncompromised Layer 7 service performance with the direct server response, the content load balancing blade relies on a software module in each server. This server module contributes to the solution’s high degree of integration by providing other key attributes, for example, path failover functionality.

The Sun Fire B1600 blade system switches are separate networks, leaving the system designer the option to connect them externally and create a symmetrically configured redundant system where every blade is dual-homed, or to leave the switches segregated for a system where full redundancy is either not necessary (or achieved elsewhere in the system hierarchy), and blades are single-homed to

separate networks. You can also create intermediate configurations where critical blades (content load balancers, proxies, and so on) reside on shelves with dual switches, but blade servers do not.

When you connect SSC switches to create redundant paths, it is best if:

- The interconnection occurs at the highest point in the network hierarchy
- The internal fabric of one shelf is connected directly to the corresponding fabric of another shelf (that is, daisy chain SSC0 with SSC0 and SSC1 with SSC1, and connect these uplinks at an external distribution switch, if any).

The above connections help ensure that the SSC switches are indeed leaf switches within the network infrastructure, and enable the content load balancer to use the shortest path within the redundant fabric (that is, the path that involves only one fabric).

FIGURE 1-3 illustrates nine shelves connected using a combination of distribution switches and internal SSC switches. Note that the SSC0 versus SSC1 fabric correspondence is preserved throughout the Layer 2 network, and that the fabrics are interconnected at the distribution switch level. In asymmetrical (capacity and hops) topologies like the one shown, it is also appropriate to house the content load balancing blades in shelves directly connected to the distribution switches.

Routers are shown for completeness as they represents the boundary of the Layer 2 network on the path towards the service clients.

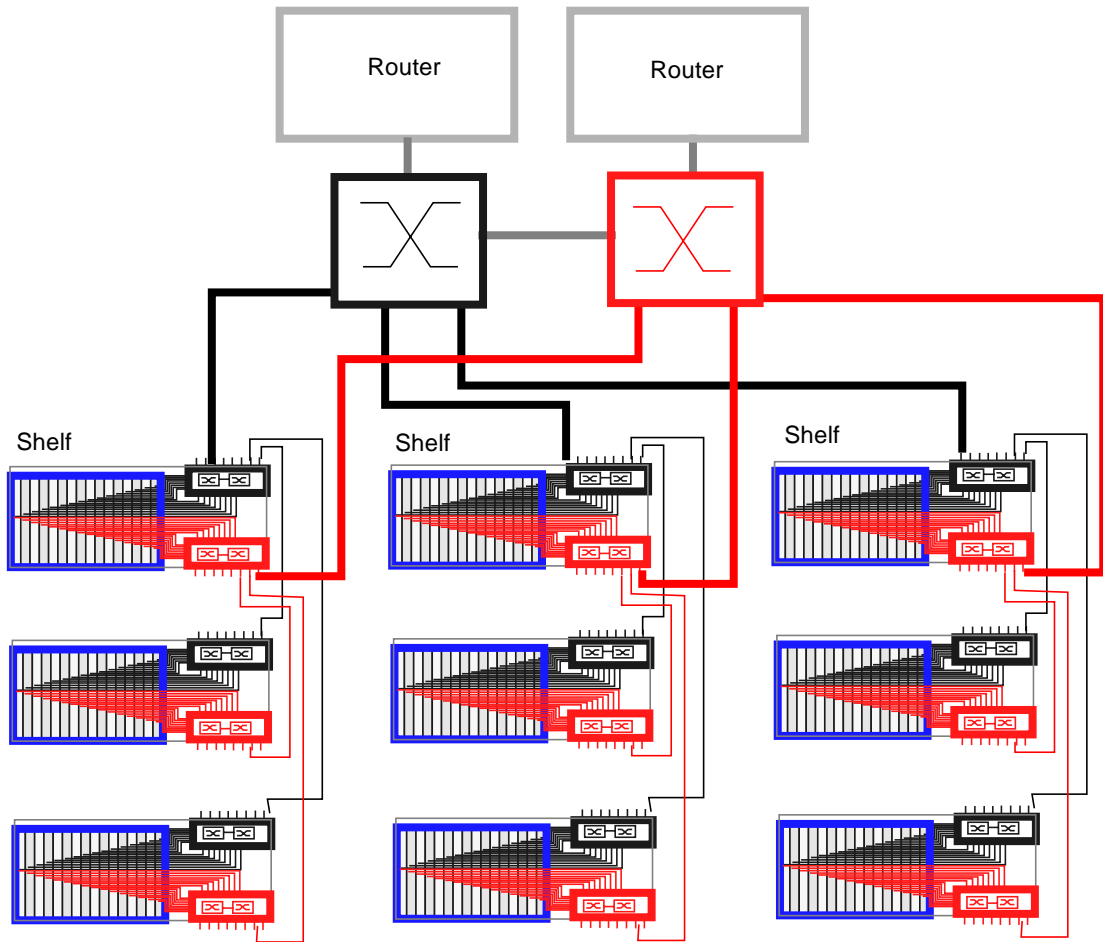

FIGURE 1-3 Sample Topology: Dual Tree Using External and Internal Switches

The Role of the B10p SSL Proxy Blade

The Sun Fire B10p SSL proxy blade is a companion product to the Sun Fire B10n content load balancing blade, and as such its role is briefly described in this section. SSL proxy blades are used to:

- Consolidate and secure storage of server side certificates (servers remain stateless in terms of long-term secrets, and can be dynamically re-purposed or replaced).
- Accelerate RSA transactions and bulk encryption and decryption.
- Enable the content load balancer to perform Layer 7 load balancing on cleartext (decrypted) cookies and URLs.

For every service the content load balancer can be configured with one or more SSL proxy blades supporting the SSL sessions of the given service. SSL requests are delegated by the content load balancer and processed after decryption. Outbound encryption requests are directed from the servers to the corresponding SSL proxy blade without going through the content load balancing blade.

The content load balancing blade, along with its server-side module, are responsible for the appropriate path selection, failover, and VLAN tag selection for SSL traffic. The resulting functionality is summarized by:

- Secure traffic in cleartext form (after decryption or before encryption) is contained to a VLAN
- Secure traffic in cleartext form (after decryption or before encryption) is contained to a single fabric (and to a single shelf if all participating blades are in the same shelf)

This book covers the configuration of SSL services at the content load balancing blade. Refer to the *Sun Fire B10p SSL Proxy Blade Administration Guide* for more information.

Failover Alternatives

The service availability obtainable from a given system is a function of the intrinsic failure rates of its components and the automatic failover capabilities of the system itself. A system designed around Sun Fire B1600 blade system product family has the following service failover aspects:

1. Server failover—This is the ability of any load balancer to remove non-responsive servers from service groups so that new requests go to functional servers. This capability is based on the server-monitoring function.
2. Path failover—This is the ability of the system to use an alternate network path whenever the current path does not appear to work, because of cable, switch, link, or end-point faults. This type of failover tends to be transparent, in the sense that session state at all endpoints is still valid and usable.
3. Blade failover—This is the ability to deploy content load balancing blades in high availability (HA) pairs that monitor each other. For a given service one of the load balancing blades is a standby blade, identically configured to the active blade,

and responsible for taking over in if the active blade fails. SSL blades do not monitor each other, and their failover is rather controlled by the load balancing blade monitoring them as if they were servers.

The system designer can decide which level of failover to design into the system:

- Server failover: always provided
- Path failover: possible whenever dual redundant switches are used. Controlled by the content load balancing blade, by its server module, and by configuring Solaris IPMP on each server for server outbound path failover (towards the router).
- Blade failover: possible whenever content load balancing blades are deployed in pairs.

The Role of VLANs

The Sun Fire B1600 blade system can use IEEE 802.1q VLANs configured into its SSC switches to create logical groups of endpoints that can communicate as if they were on the same LAN, and equally importantly to prevent or restrict traffic between endpoints on separate VLANs.

Switches are responsible for VLAN enforcement, based on the VLAN Identifiers present on Ethernet packets (explicitly or implicitly), as well as the physical ingress and egress switch ports involved.

To the simple examples of data versus management separation already mentioned, or the web traffic versus backend network separation, we can add that in a multi-tenant environment it is also appropriate to separate traffic based on the service 3-tuple. A VLAN Identifier can be assigned by the content load balancing blade to identify the tenant (that is, the service owner), and thus ensure that its requests can only go to said tenant servers. In combination with the server side VLAN configuration, you can use VLANs to separate:

- blade servers of different tenants
- Different tiers of a given tenant (web tier, application server, NFS, management)
- Pre- and post-encryption traffic of a given SSL service

System Integration

Although this book describes the administration of the Sun Fire B10n content load balancing blade at the lowest possible level, you may want to approach system integration (that is via CLI and scripting), it is certainly possible and desirable to achieve higher levels of integration abstraction with other Sun software products like N1 deployment, and SunOne Web and Portal Servers.

When considering system integration, the main Sun Fire B10n content load balancing blade considerations are:

- Sun Fire B10n content load balancing blade includes a specialized Layer 7 classifier engine, therefore there is no performance penalty for defining services at Layer 7 versus Layer 4.
- Layer 7 semantics may be used for either persistence (cookies) or content structure (URL), or both.
- Using Layer 7 semantics with HTTP 1.1 requires the content to be accessible from any of the servers in the server group, as HTTP load balancing occurs on TCP connection boundaries rather than request boundaries.

Usage Overview

The Sun Fire B10n content load balancing blade has two levels of user access:

- Supervisor—In the Level 2 access mode, you can access all commands. You can add or change user name, password, and access level.
- General—In the Level 1 access mode, you can query the system status and configuration, but you cannot modify the configuration.

Command Modes

Some of the commands are accessible only with the right user access level. Even within a single user access level, there are different command modes.

- Config—In this mode, all the configuration commands are accessible. Only supervisor level users can access this mode by typing `config` at the command prompt.
- Non-config—Commands that do not affect the configuration are available in this mode.

- All—Listing commands (`show` and `dump`) can be accessed in any mode by any user.

The examples in this book use the following format:

```
hostname( command_mode ) { user_name }# command
```

For example:

```
puma{admin}# show user
```

- *hostname* is puma
- *command-mode* is non-config
- *user-name* is admin (supervisor)
- *command* is `show user`

```
puma(config){admin}# ip interface 0 192.50.50.134 mask  
255.255.255.0
```

- *hostname* is puma
- *command-mode* is config
- *user-name* is admin (supervisor)
- *command* is `ip interface 0 192.50.50.134 netmask 255.255.255.0`

Installing the Blade and Setting Up the System

This chapter describes how to install the hardware.

This chapter contains the following sections:

- “Installing the Hardware” on page 15
 - “Location of Ports” on page 20
 - “Powering On Content Load Balancing Blades” on page 24
 - “Powering Off Content Load Balancing Blades” on page 26
-

Installing the Hardware

The instructions in this section are specific to installing the Sun Fire B10n content load balancing blade into the Sun Fire B1600 blade system chassis. However, you should still refer to the documentation that came with your system for more complete information.

▼ To Install the Hardware

Note – To ensure adequate airflow, you must populate all 16 blade slots of the Sun Fire B1600 blade system chassis with either blades or filler panels before you apply power to the system chassis. Do not leave any slots empty.

- 1. Remove the filler panel from an unpopulated slot in a Sun Fire B1600 Blade system chassis or other supported system.**

Insert your finger in the pull recess located in lower portion of the filler panel lever and pull gently to disengage the locking mechanism (FIGURE 2-1).

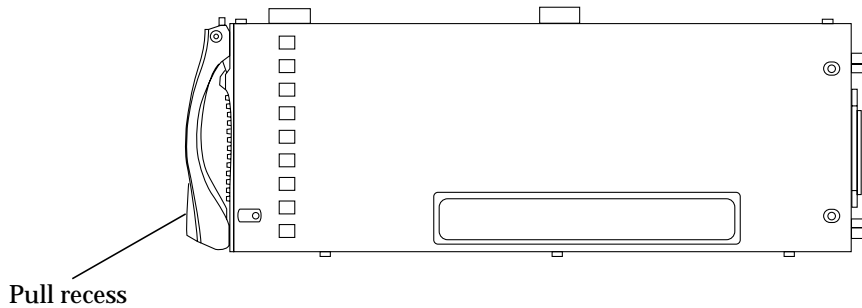

FIGURE 2-1 The Filler Panel Locking Mechanism

- 2. Pull the lever mechanism in a forward and upward motion, causing the filler panel lever to unlatch and eject the filler panel partially from the system chassis (FIGURE 2-2).**

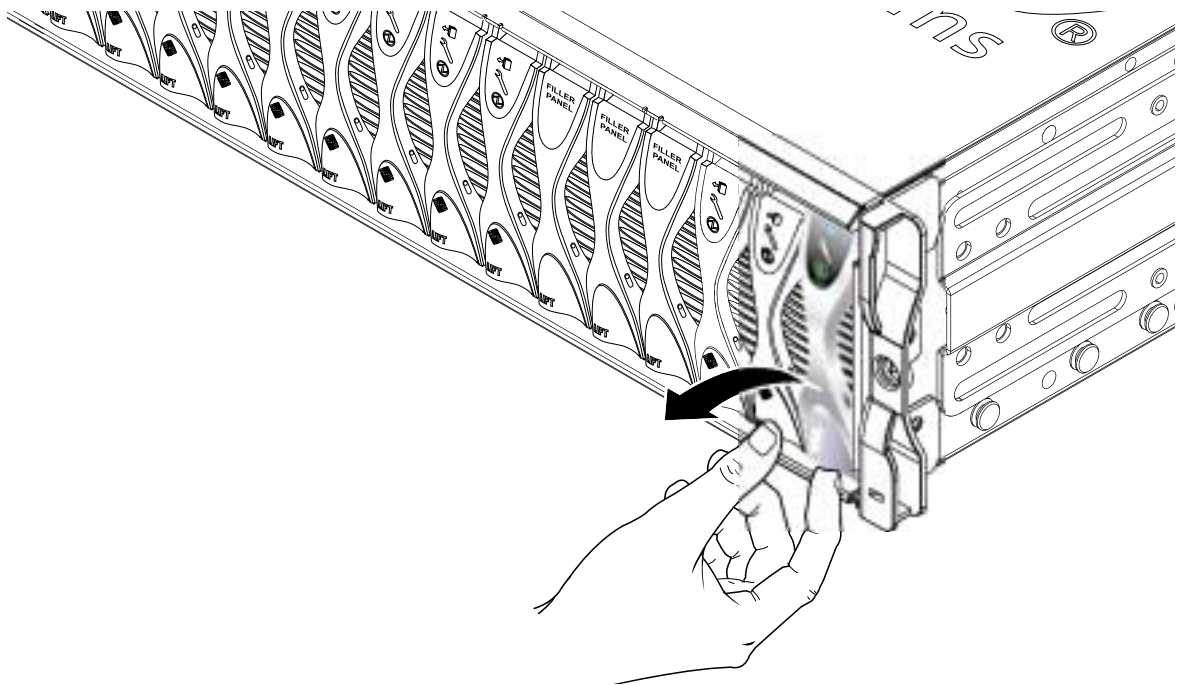

FIGURE 2-2 Disengaging the Blade-Locking Mechanism

3. Pull the lever to remove the filler panel from the system chassis (FIGURE 2-3).

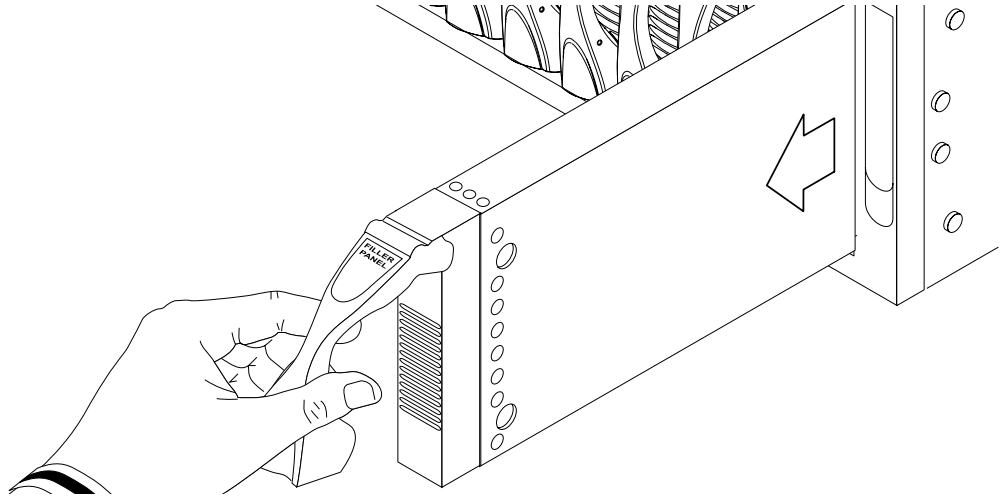

FIGURE 2-3 Removing the Filler Panel

4. If required, open the blade lever by inserting a finger in the pull recess located in lower portion of the blade lever and pull the lever mechanism in a forward and upward motion, causing the lever to unlatch (FIGURE 2-4).

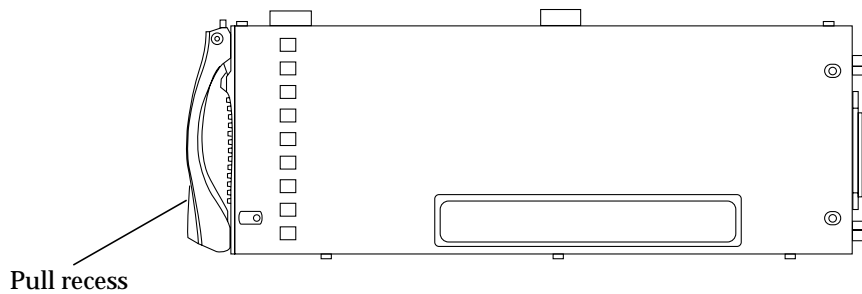

FIGURE 2-4 Blade Locking Mechanism

5. Align the Sun Fire B10n content load balancing blade with an empty slot in the system chassis.

Ensure that the blade connector is facing towards the system chassis, with the hinge point of the lever mechanism uppermost, and support the bottom of the blade with your free hand while lifting the blade up to the system chassis (FIGURE 2-5).

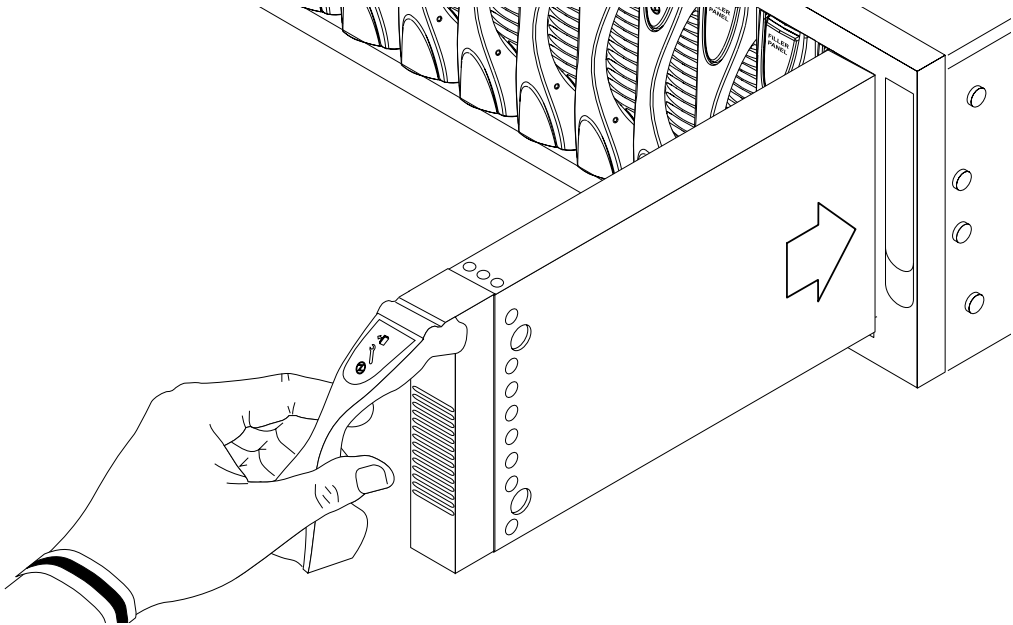

FIGURE 2-5 Aligning and Inserting the Blade

6. Insert the Sun Fire B10n content load balancing blade into the system.

Caution – Ensure that the blade engages with the system chassis guidance system. Failure to align the blade correctly can result in damage to the chassis midplane or the blade connection.

7. Gently push the blade into the slot until the blade latch ears, on top of the lever, are positioned in the chassis (FIGURE 2-6).

8. Complete the hardware installation by closing the blade lever fully, which engages the blade into the chassis slot (FIGURE 2-6).

The green LED flashes as the blade powers up, and glows steadily when the blade is up and running.

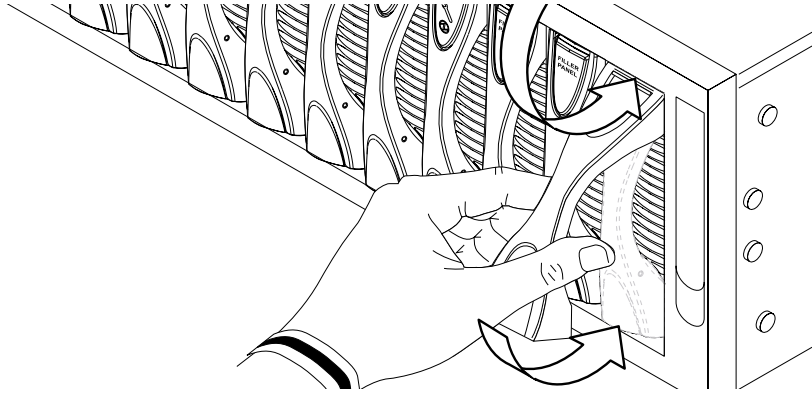

FIGURE 2-6 Closing the Blade Lever Mechanism

LED Displays

Use the LEDs on the individual system components to determine if the system is operating normally. Monitor LEDs routinely on the:



- Power Supplies
- Load balancing blades

The LEDs can be off, on, or flashing. When the fault LED is on (lit), this indicates that a fault has occurred in the component. A fault is any condition that is considered to be unacceptable for normal operation. When the fault LED is lit, you must take immediate action to clear the fault. You can only remove a hot-swappable component when the blue Removal OK LED is lit.

TABLE 2-1 lists the LED status codes for the following hot-swappable components:

- Blades
- Power Supply

TABLE 2-1 Blade and Power Supply Status Codes

Power (Green)	Fault (Amber)	OK to Remove (Blue)	Indication	Corrective Action
				
Off	Off	Off	Component not operating. Fault condition unknown.	You can remove a component from the system.
Off	On	Off	Component not operating. Fault condition present.	You cannot remove a component from the system.
Off	Off	On	Component not operating. No fault condition present.	You can remove a component from the system.
Off	On	On	Component not operating. Fault condition unknown.	You can remove a component from the system.
On	Off	Off	Normal component operation.	N/A
On	Off	On	Component not operating. No fault condition present.	You can remove a component from the system.
On	On	Off	Component operating. Fault condition present.	You cannot remove a component from the system.
On	On	On	Component operating. Fault condition present.	You can remove a component from the system.
Flashing	Off	Off	Component is powering up.	N/A

Location of Ports

All ports are located at the back of the Sun Fire B1600 blade system chassis. These connections are shown in FIGURE 2-7.

Note the location of the following ports:

- 10/100BASE-T network management cables
- 10/100/1000BASE-T data network cables
- RS232 serial cables

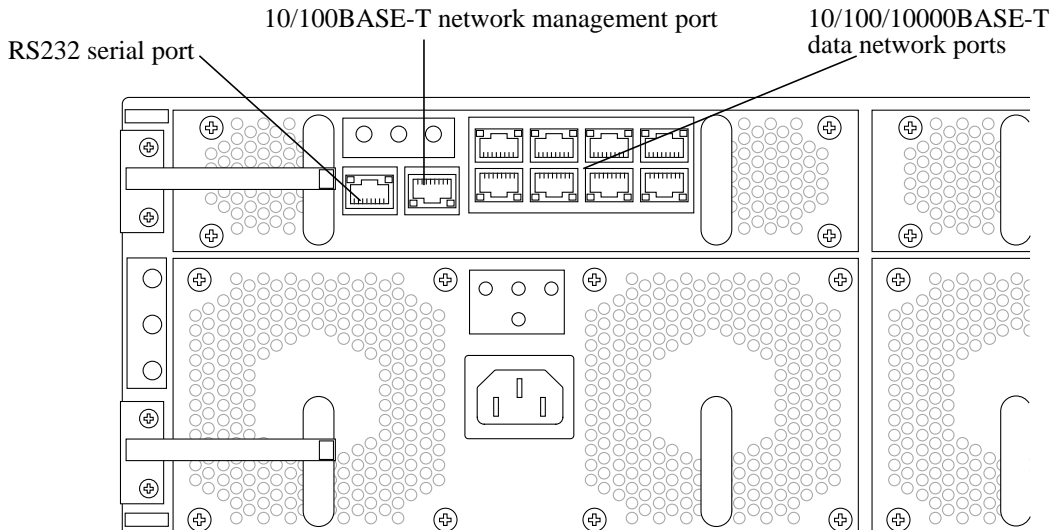

FIGURE 2-7 External Cable Connections



Caution – Do not connect a telephone jack connector to any RJ-45 port. This can damage the switch. Instead, use only twisted-pair cables with RJ-45 connectors that conform with FCC standards, or local national wiring or electrical regulations.

Note – Twisted-pair cables must not exceed 328 feet (100 meters).

Connecting to the 10/100/1000BASE-T Data Network Ports

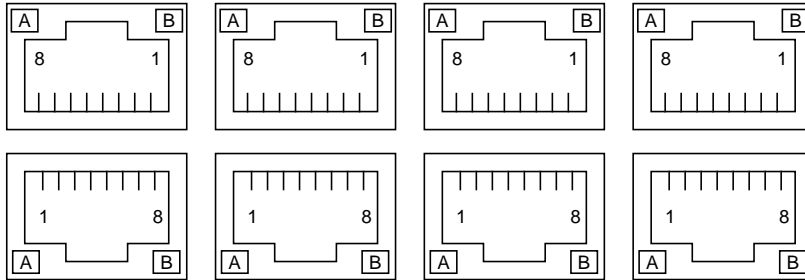

FIGURE 2-8 The 10/100/1000BASE-T Data Network Ports

Arranged as a 4x2 array, these RJ-45 ports provide the connection to the combined switch and service processor. Each port has integral green Link Present and Link Active LED indicators.

Note – The Link Present indicator is always on the left, regardless of the orientation of the RJ-45 port.

TABLE 2-2 10/100/1000BASE-T Data Network Port Pinouts

Pin 1	Pin 2	TRD0-
Pin 3	Pin 4	TRD2+
Pin 5	Pin 6	TRD1-
Pin 7	Pin 8	TRD3-
LED A	LED B	Link Active

Serial Port Pin Numbers

Viewing the Sun Fire B1600 blade system chassis from the back, pin 1 of the RJ-45 serial port is on the left, and pin 8 is on the right.

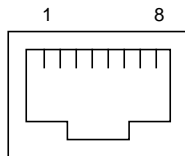

FIGURE 2-9 Serial Port Pin Numbers

TABLE 2-3 Serial Port Pinouts

Pin number on System Chassis	Signal
Pin 1	RTS
Pin 2	DTR
Pin 3	TXD
Pin 4	Signal Ground
Pin 5	Signal Ground
Pin 6	RXD
Pin 7	DSR
Pin 8	CTS

Powering On Content Load Balancing Blades

Note – To power on any content load balancing blade, you must have access to the system controller and r-level user permission. Refer to the *Sun Fire B1600 Blade System Chassis Administration Guide* for information on system controller user permissions.

- **To power on a single blade, type:**

```
SC> poweron Sn
```

Where S indicates the slot and *n* is the number of the slot containing the blade you want to power on. Valid slot numbers range from 0 to 15.

- **To power on more than one blade, specify each blade in a space-separated list as in the following example:**

```
SC> poweron S6 S11
```

Or, if any of the blades is in a continuous range, you can specify the range. For example, to power on the blades in slot 6 and also the blades in slots 8 through 10, you would type the following:

```
SC> poweron S6 S[8-10]
```

- Use the `showplatform` command to verify the status of the B10n blade:

```

sc> showplatform

FRU          Status          Type
-----
S0           OK              SF B100s
S1           OK              SF B100s
S2           OK              SF B100s
S3           OK              SF B100s
S4           Not Present     ***
S5           Not Present     ***
S6           Not Present     ***
S7           Not Present     ***
S8           Not Present     ***
S9           Not Present     ***
S10          Not Present     ***
S11          Not Present     ***
S12          Not Present     ***
S13          Not Present     ***
S14          OK              SF B10n
S15          OK              SF B10n
SSC0         OK              SF B1600 SSC
SSC0/SC
SSC0/SWT
SSC1         Not Present     ***
SSC1/SC
SSC1/SWT
PS0          OK              SF B1600 PSU
PS1          OK              SF B1600 PSU
CH           OK              SF B1600

Domain      Status
-----
S0          OS Running
S1          OS Running
S2          OS Running
S3          OS Running
S14         OS Running
S15         OS Running
SSC0/SWT    OS Running
SSC0/SC     OS Running (Active)

```

Note – Slots 14 and 15 show that the B10n blade is OK.

Powering Off Content Load Balancing Blades

Note – To power off any content load balancing blade, you must have access to the system controller and r-level user permission. Refer to the *Sun Fire B1600 Blade System Chassis Administration Guide* for information on system controller user permissions.

Note – All the various options in this section can be used on the same command line except for the `-r` and `-s` commands: these two are alternatives to each other.

Powering Off With an Orderly Shutdown of the Operating System

The `poweroff` command attempts to shut down the operating system on a blade or blades in an orderly fashion. The command also prompts you to confirm that you intend to shutdown the blade or blades you have specified.

- **To power off a single blade, type:**

```
sc> poweroff sn
```

Where *n* is the number of the slot containing the blade you want to power off.

- **To power off more than one blade, specify each blade in a space-separated list as in the following example:**

```
sc> poweroff s6 s11
```

Or, if any of the blades are in a continuous range, you can specify the range. For example, to power off the blades in slot 6 and also the blades in slots 8 through 10, you would type the following:

```
sc> poweroff s6 S[8-10]
```

Forcing the Power Off

The `poweroff` command attempts to shutdown the operating system on a blade in an orderly fashion. If this orderly shutdown fails on a particular blade, the `poweroff` command will not continue to power off the blade.

- **To force the blade to power off even if an orderly shutdown has failed, include the `-s` option on the command line, as in the following example:**

```
sc> poweroff -s S6
```

Powering Off a Load Balancing Blade Without Requiring the Confirmation Prompt

When you run the `poweroff` command to power off a blade, you are prompted to confirm that you intend to power off the blade you have specified.

- **To avoid receiving the confirmation prompt when you use the `poweroff` command, include the `-y` option on the command line.**

For example:

```
sc> poweroff -y S6 S11
```

Powering a Load Balancing Blade Down to Standby Mode to Save Power

There are two ways to power a blade down to standby mode. You can use either the `standbyfru` command or the `poweroff` command.

- **To power down a blade or blades to standby mode using the `poweroff` command, type:**

```
sc> poweroff -s Sn
```

Where *n* is the number of the slot containing the blade you want to power down. When a blade is in standby mode, the system service processor continues to monitor its operational state.

Note – You cannot use the `-s` option on the same command line as the `-r` option.

- To power down a blade to standby mode using the `standbyfru` command, type:

```
sc> standbyfru Sn
```

Where *n* is the number of the slot containing the blade you want to power down. When a blade is in standby mode, the system service processor will continue to monitor its operational state.

- To power down more than one blade to standby mode, specify each blade in a space-separated list, as in the following example:

```
sc> standbyfru S6 S11
```

Powering Off a Content Load Balancing Blade to Remove It

- To power down a blade or blades for removal, type:

```
sc> poweroff -r Sn
```

Where *n* is the number of the slot containing the blade you want to power down. When a blade is powered off for removal, its OK to Remove LED is lit.

Note – You cannot use the `-s` option on the same command line as the `-r` option.

Preparing the Sun Fire B10n Content Load Balancing Blade for Load Balancing

To prepare the Sun Fire B10n content load balancing blade for load balancing, you must first configure the blade servers, then set up the content load balancing blade. This chapter describes the procedures for preparing the blade servers for load balancing.

This chapter includes the following sections:

- “Configuring the Blade Servers” on page 29
- “Setting Up the Load Balancing Blade” on page 33
- “Completing the Basic Configuration” on page 36

Configuring the Blade Servers

The Sun Fire B10n software includes the following components:

- Blade server module
- B10n application software
- BSC firmware

See “Software Architecture” on page 2 to understand the different software components.

The procedures for downloading both the blade server module software and the B10n application software as well as the firmware on the Sun Fire B10n content load balancing blade involve downloading the software to your TFTP server.

If you are updating the blade server module before downloading the software, check the blade server module software version.

▼ To Check the Blade Server Module Software Version

1. At the `sc` prompt enter the following command:

```
sc> console Sn
```

Where *S* indicates the slot and *n* is the number of the slot containing the blade you want to access. Valid slot numbers range from 0 to 15.

2. At the Solaris root prompt, check the module information:

```
# modinfo | grep clbmod
```

The following example checks the blade server module software of the blade in slot 10:

```
sc> console s10  
Connected with input enabled on fru S10  
Escape Sequence is '#.#'(#.)
```

The information shows that software version 1.34 is currently installed.

```
# modinfo | grep clbmod  
213 78160000 d18f 21 1 clbmod (Server CLB module v1.34)
```

▼ To Set Up the Blade Server

1. To download the latest software, go to the following site and select Sun Fire B10n:

<http://www.sun.com/software/download/network.html>

2. Unzip the file.

```
# /usr/bin/unzip SunFire_B10n-1_0.zip
```

3. Install the blade server module software packages:

```
# cd path_to_unzipped_file/solaris_8/Packages
# pkgadd -d .
```

Step 3 shows an example of a Solaris blade server module.

You will see a message similar the following:

```
The following packages are available:
 1  SUNWclbut      Sun Content Load Balancing Utilities
                        (sparc) 1.0,REV=2003.04.18
 2  SUNWclbx.u    Sun Content Load Balancing Module (64-bit)
                        (sparc.sun4u) 1.0,REV=2003.04.18

Select package(s) you wish to process (or 'all' to process
all packages). (default: all) [?,??,q]:
```

4. Press return to install all the packages.

5. Install the blade server module on each blade server.

The blade server module must be installed on each blade server individually. You can install the packages from the blade server to the TFTP server.

6. Configure the management IP address to the server interface:

```
# /usr/sbin/ifconfig ce0 plumb ip_address netmask netmask up
```

7. To configure interfaces to remain across reboots, add the interfaces to `/etc/opt/SUNWclb/clb.conf` placing each interface on a separate line to be configured at start up. Or run the `clbctl` script after creating the file and adding the interfaces.

```
# /etc/init.d/clbctl start
```

Following is a sample configuration file:

```
#
# Copyright (c) 2003 by Sun Microsystems, Inc.
# All rights reserved.
#
# ident "@(#)clb.conf 1.2 03/01/08 SMI."
#
# This file lists the interfaces to be configured with the content
# load balancing module (CLB). On boot these interfaces are
# configured for content load balancing. The interfaces are
# specified one per line.
# Interfaces configured for VLAN and are part of the load balancing
# are also
# listed here.
# Example:
ce123000
ce1
ce0
```

8. Configure the virtual IP addresses (VIPs) that this server supports:

```
# ifconfig virtual loopback interface plumb vip netmask netmask up
```

You must configure the virtual IP address of the service being load balanced. If it is not configured, the stack will not recognize the destination address in the incoming IP packets and will reject packets received for that destination address. Configure the virtual IP address on the loop back interface as a logical IP address. Using the loop back interface prevents responses to incoming ARP request broadcasts for the virtual IP address. Use different loop back instances for different virtual IP addresses.

For example if the server supports VIP 192.50.50.1, you would type the following:

```
# ifconfig lo0:1 plumb 192.50.50.1 netmask 255.255.255.0 up
```

Setting Up the Load Balancing Blade

To make the content load balancing blade functional, you must first set it up. Once you are at the B10n prompt, you can get help by doing either of the following:

- **At the B10n prompt, type the following command:**

```
puma# help command_name
```

- **At the B10n prompt, type a question mark:**

```
puma# service ?
```

▼ To Set Up a Content Load Balancing Blade

1. **Connect your telnet console with a Sun Fire B1600 blade system chassis serial port.**
2. **Telnet into the system controller (sc):**

```
% telnet sc ip_addr
```

Where *ip_addr* is the IP address of the system controller.

3. **To power on a single content load balancing blade, type the following:**

```
sc> poweron Sn
```

Where *S* indicates the slot and *n* is the number of the slot containing the blade you want to power on.

If you are powering on more than one blade, list the slot number for each blade you are powering on. See “Powering On Content Load Balancing Blades” on page 24.

4. **Access the console for the blade:**

```
sc> console Sn
```

5. Login as admin to access the command line interface:

```
puma# Login:admin
Password:admin
puma{admin}#
```

Note – The default login and password for the administrator is `admin`. To ensure the security of the configuration, change the default password before you continue. The new password must have at least six characters. See “User Access” on page 40 for more information.

6. Change the default password:

```
puma{admin}# password admin
Enter new password: new admin secret password
Confirm new password: new admin secret password
```

7. Enter config mode:

```
puma{admin}# config
puma(config){admin}#
```

8. Configure an IP interface:

```
puma(config){admin}# ip interface 0 ip-addr mask net-mask
```

This command sets up the `iq0` on your content load balancing blade, that is the interface connected to switch SSC0 (in slot 0).

Note – The switch number, for example SSC0, corresponds to the slot where the blade server resides.

The following example sets the IP address on interface 0 at 192.50.50.134 :

```
puma(config){admin}# ip interface 0 192.50.50.134 mask
255.255.255.0
```

Each Sun Fire B10n content load balancing blade has two interfaces. Alternatively, you could configure the second interface as follows:

```
puma(config){admin}# ip interface 1 ip-addr mask net-mask
```

This alternative configuration sets up the `iq1` on your content load balancing blade, that is the interface connected to switch SSC1 (in slot 1).

The following example sets the IP address on interface 1 at 192.50.50.135:

```
puma(config){admin}# ip interface 1 192.50.50.135 mask
255.255.255.0
```

9. Verify that the interface is working:

```
puma(config){admin}# ping remote-ip-addr
```

The following example pings the remote IP address at 192.50.50.200 :

```
puma(config){admin}# ping 192.50.50.200
```

Note – Ensure that the `remote-ip-addr` is reachable from the Sun Fire B10n content load balancing blade before you complete the basic configuration.

Completing the Basic Configuration

Before the Sun Fire B10n content load balancing blade can be configured to do basic load balancing, you must at minimum, configure a default gateway, and DNS server, a service, and a group.

▼ To Configure a Default Gateway

- As admin in config mode, set the default gateway:

```
puma(config){admin}# default gateway ip_addr
```

The following example configures the default gateway as 192.50.50.200:

```
puma(config){admin}# default gateway 192.50.50.200
```

▼ To Configure the DNS Server

- As admin in config mode, configure the primary DNS server:

```
puma(config){admin}# dns server 192.50.50.100 primary
```

▼ To Configure DNS Suffix

- As admin in config mode, configure the DNS suffix:

```
puma(config){admin}# dns suffix mycompany.com
```

▼ To Commit the Configuration

- As admin in config mode, commit the configuration you just set up:

```
puma(config){admin}# commit
```

▼ To Verify the Configuration

- As admin, verify the configuration you just set up:

```
puma{admin}# show network
Network Interface
-----
interface 0

        IP address 192.168.101.251      netmask 255.255.255.0
        MAC address: 0:3:ba:2c:73:a0
        configured: yes
        link: up          path: up

interface 1

        MAC address: 0:3:ba:2c:73:a1      (interface not configured)

Default Gateway
-----
192.168.101.1

Hostname
-----
G-251a

DNS
-----
Primary 192.168.101.1
Secondary (not configured)
suffix: mycompany.com

VLAN
-----
Management ID [1]          (not enabled)
Data ID [1]                (not enabled)

Monitoring
-----
Server: interval 3 (seconds)    retry 5
```

Note – The output from the show network command is only an example of the data provided. Your output will be different.

Command-Line Options

This chapter describes the management and control interfaces available through the Sun Fire B10n content load balancing blade command line interface (CLI). It lists the CLI commands under the various management categories with the appropriate options.

This chapter includes the following sections:

- “User Access” on page 40
- “Configuring the Networking” on page 44
- “Monitoring” on page 50
- “Configuring the Content Load Balancing Blade” on page 56
- “Load Balancing Service Configuration and Management” on page 59
- “Server Configuration” on page 78
- “Load Balancing Rule Configuration” on page 80
- “Load Balancing Group Configuration and Management” on page 85
- “Load Balancing Configuration Listings” on page 94
- “Configuring the System” on page 97
- “Flash File System Commands” on page 108
- “Other Useful Commands” on page 111

Note – While you can enter multiple commands in the CLI, no command can be longer than 255 characters. Hence, commands longer than that must be divided into as many commands as necessary to stay within the 255 character limitation.

Typographic Conventions Specific to the Sun Fire B10n Command Line Interface

Command descriptions use these conventions:

- Commands and keywords are in **boldface** in code boxes, and in *courier* in tables and text.
- Arguments for which you supply values are in *italic* in code boxes, tables, and text.
- Required options are grouped in braces ({ }) and separated by vertical bars (|).
- Optional elements are grouped in square brackets ([]) and separated by vertical bars (|).

Note – Keywords are not case-sensitive, but user-specified values are.

User Access

The Sun Fire B10n content load balancing blade has two levels of user access:

- **Supervisor**—In the Level 2 access mode, you can access all commands. You can add or change user name, password, and access level.
- **General**—In the Level 1 access mode, you can query the system status and configuration, but you cannot modify the configuration.

TABLE 4-1 describes the user commands.

TABLE 4-1 user Commands

Command	Description
<code>user password</code>	Changes the password. System responds with a prompt for the new password. Then prompts for confirmation of the new password.
<code>user access</code>	Access level assigned to a user. 1 = the general access level with read-only permission.. 2 = the highest access level with access to all commands.
<code>user add</code>	Adds a user.
<code>user delete</code>	Deletes a particular user's ability to access the system.
<code>user show</code> <code>show user</code>	Lists all users currently existing in the system, along with their respective access levels.

Using the login Command

The `login` command is used to log in initially as the administrator. It can also be used to log in as another user with a different access level than the one you currently have.

The `login` command has no defaults and can be used at any access level. The corresponding command is `logout`.

Note – For security reasons, always `logout` before you leave the console.

▼ To Log In as Administrator

1. Access the console for the blade:

```
sc> console Sn
```

Where *S* indicates the slot and *n* is the number of the slot containing the blade you want to configure.

2. Log in as `admin` to access the command-line interface:

```
Login: admin
Password: admin
puma{admin}#
```

Note – The default `admin` password is `admin`. To ensure security, change the default password before configuring the content load balancing blade.

3. Change the admin password:

```
puma{admin}# user password admin
Enter new password:
Confirm new password:
```

Adding Users

Only the administrator (Supervisor) with Level 2 access can add new users who can be given all the privileges of the administrator or limited privileges, depending on the assigned access level. By default, the user is created with Level 1 access..

Note – If you do not specify the access level when you add a user, the default access (Level 1) will be used.

TABLE 4-2 lists the parameters for `user access` command:

TABLE 4-2 Parameter Description for User Access

Parameter	Description
<i>user_name</i>	Login name of the user.
<i>access</i>	Qualifier for the access level assigned to the new user.
1	General (intermediate) access level.
2	Supervisor (highest) access level.

▼ To Add a User

- **As admin, you can add new users, assign access level, and a default password:**

```
puma{admin}# user add name user_name [access {1/2}]  
puma{admin}# user access name user_name access {1/2}  
puma{admin}# user password login-name
```

▼ To Change the User Access Level

- As admin, you can change a user's access level:

```
puma{admin}# user access name user_name access {1/2}
```

The following example changes the access level of user1 to 1.

```
puma{admin}# user access name user1 access 1
```

▼ To Change the User Password

- As admin, you can change a user's password level:

```
puma{admin}# user password user_name
Enter new password:*****
Confirm new password:*****
puma{admin}#
```

▼ To Remove a User

- As admin, you can remove a user:

```
puma{admin}# user delete user_name
```

▼ To List All Users

- As admin, you can list all users:

```
puma{admin}# user show
```

You can also list all users with the `show user` command:

- As admin, you can list all users:

```
puma{admin}# show user
```

Both commands list all users currently existing in the system, along with their respective access levels.

Configuring the Networking

This section describes how to configure the network for the Sun Fire B10n content load balancing blade

▼ To Configure the Management IP Address

1. As admin, enter config mode:

```
puma{admin} # config
```

2. Set up the IP address:

```
puma(config){admin}# ip interface {0|1} ip_addr mask net_mask
```

The `config ip interface` command configures the IP address on the content load balancing blade to be used for management and control. Use this IP address for tasks such as opening a telnet session on the content load balancing blade.

TABLE 4-3 describes the parameters for setting the real IP addresses.

TABLE 4-3 Parameters for Setting the IP Address

Parameter	Description
interface	Qualifier for the interface
0	Interface 0
1	Interface 1

TABLE 4-3 Parameters for Setting the IP Address *(Continued)*

Parameter	Description
ip_addr	IP address.
mask	Qualifier for the subnet mask.
subnet	Subnet mask for the real address.

Examples

The first example sets the IP address on interface 0 as 192.50.50.144 and the subnet mask as 255.255.255.0.

```
puma(config){admin}# ip interface 0 192.50.50.144 mask
255.255.255.0
```

The following example sets the IP address on interface 1 as 192.50.50.145 and the subnet mask as 255.255.255.0.

```
puma(config){admin}# ip interface 1 192.50.50.145 mask
255.255.255.0
```

Note – The IP addresses shown in Examples 1 and 2 are different from virtual IP (VIP) addresses. The Sun Fire B10n content load balancing blade does not load balance traffic destined to these IP addresses.

▼ To Send a ping Request

- **As any user, enter the ping command along with the specific IP address or hostname you want to ping and the packet count:**

```
B10n {user} # ping {ip_address / host_name} [packet_count]
```

The ping command determines whether the Sun Fire B10n content load balancing blade has connectivity or whether a host is available on the network. The command output shows whether the response was received, that is, the host exists on the network.

If the host is not responding then `ping` displays this message:

```
no answer from host
```

If the host is available on the network then `ping` displays this message:

```
host is alive
```

TABLE 4-4 describes the parameters for sending a `ping` request.

TABLE 4-4 Variables for Sending a `ping` Request

Variables	Description
<i>ip_addr</i>	IP address of a host on the network
<i>host_name</i>	Name of a host on the network
<i>packet_count</i>	Number of tries

▼ To Unconfigure a Network Interface

- **As admin in config mode, unconfigure the network interface:**

```
puma(config){admin}# no ip interface {0|1}
```

This command unconfigures a network interface on the Sun Fire B10n content load balancing blade.

▼ To Configure a DNS Server

You can configure both a primary and a secondary Domain Name Server (DNS) for the Sun Fire B10n content load balancing blade. When supplied with a hostname, the DNS server resolves it and obtains the corresponding IP address.

- **As admin in config mode, configure a DNS server:**

```
puma(config){admin}# dns server ip_addr {primary|secondary}
```

▼ To Remove a DNS Server

- As admin in config mode, remove a DNS server:

```
puma(config){admin}# remove dns server ip_addr
```

▼ To Configure the DNS Suffix

- As admin in config mode, configure the DNS suffix:

```
puma(config){admin}# dns suffix suffix_name
```

This sets the suffix to be added to the hostnames before resolution with a DNS resolver to get the IP address.

Note – For example, a DNS suffix might be mycompany.com.

▼ To Show DNS Use

- As any user, enter the `show network` command:

```
puma{user}# show network
```

▼ To Unconfigure the DNS Suffix

- As admin in config mode, remove the DNS suffix:

```
puma(config){admin}# no dns suffix
```

▼ To Configure the Default Gateway

- As admin in config mode, set the default gateway:

```
puma(config){admin}# default gateway ip_addr
```

Where *ip_addr* is the gateway IP address.

▼ To Unconfigure the Default Gateway

- As admin in config mode, unset the default gateway:

```
puma(config){admin}# no default gateway
```

▼ To Set the Default Hostname

- As admin in config mode, set the default hostname:

```
puma(config){admin}# default hostname host_name
```

This example configures the default hostname as B10n-no-1:

```
puma(config){admin}# default hostname B10n-no-1
```

After you set up the hostname, your CLI prompt takes the hostname:

```
B10n-no-1(config){admin}#
```

▼ To Show the Network Configurations

- As any user, enter the `show network` command:

```
puma{user} # show network
```

This command returns the following information:

- IP address and netmask on the two interfaces
- The default gateway
- The DNS server and suffix configurations
- The management VLAN
 - If set, what is the value
 - Whether it is enabled or not
- The default data VLAN
 - If set, what is the value
 - Whether it is enabled or not.
- The server monitoring information

▼ To Show ARP Entries

1. As admin, enter the `show arp` command:

```
puma{admin}# show arp
```

The output from this command shows all the entries in the ARP table.

The following example shows a typical output from the `show arp` command:

```
LINK LEVEL ARP TABLE
destination      gateway          flags Refcnt  Use      Interface
-----
192.50.50.11     00:03:af:26:73:07405  0      35330      iq0
192.50.50.12     00:03:af:26:97:fb405  1      16653      iq0
-----
```

Note – In the arp table the gateway and flags columns are improperly shown. In the example above, 405 should align under the flags heading. However, the gateway and flags fields are merged. The incorrect merging is a limitation of the underlying software.

To Configure the Subnet Mask for a VIP

- As admin in config mode, configure the subnet mask for a VIP:

```
puma(config){admin} # vip-netmask {ip_addr | host_name} mask net_mask
```

TABLE 4-5 describes the parameters for configuring the subnet mask for a VIP.

TABLE 4-5 Parameters for Configuring the Subnet Mask for a VIP

Parameter	Description
<i>ip_addr</i>	VIP address.
<i>host_name</i>	Host name for the VIP.
<i>mask</i>	Qualifier for the net mask.
<i>net_mask</i>	Subnet mask. This should be in the xxx.xxx.xxx.xxx format.

▼ To List the VIPs Configured

- As any user, enter the `show vip` command:

```
puma{user}# show vip
```

This command lists all the VIPs configured on the Sun Fire B10n content load balancing blade.

Monitoring

The blade servers are monitored for health and connectivity. This involves collecting data such as server response time (or server load), network latency to a server, whether the server is up, whether the network (either the network connection between the content load balancing blade and the server or the network interface on the server) is up, and so on. The actual data collection on each server is performed by a control module residing on the server. The statistics are obtained by the

management module on the Sun Fire B10n content load balancing blade using SNMP. You can check network connectivity by issuing a ping to each blade server from the monitoring module in the content load balancing blade.

▼ To Set Up Server Monitoring

- As admin in config mode, set the server for monitoring:

```
puma(config){admin} # server-monitor [interval monitoring_interval]
[ max-try max_try_count]
```

The `config server-monitor` command configures the monitoring parameters for detecting loss of connectivity to a back end server or a failure of the server itself.

TABLE 4-6 describes the parameters for setting up a server for monitoring.

TABLE 4-6 Parameters and Variables for Setting Up a Server for Monitoring

Parameters and Variables	Description
<code>interval</code>	(Optional) Qualifier for the value specified in the <i>monitoring_interval</i> argument.
<i>monitoring_interval</i>	(Optional) The time interval (in milliseconds) in which the monitoring messages are sent.
<code>max-try</code>	(Optional) Qualifier for the value specified in the <i>max_try_count</i> argument.
<i>max_try_count</i>	(Optional) The maximum number of tries for the monitoring messages before marking a server down.

Configuring SSL Blade Entries

The Sun Fire B10n content load balancing blade can be configured to work in conjunction with one or more SSL proxy blades for content load balancing SSL traffic. You must configure an SSL entry on the content load balancing blade for each SSL proxy blade in the system.

▼ To Add an SSL Blade

The `config ssl name` command adds an entry for an SSL proxy blade on the content load balancing blade with at least one interface configured.

- **As admin in config mode, enter the `ssl name` command and the parameters:**

```
puma(config){admin}# ssl name ssl_blade_name {ssl_ip_1 | host_name_1}  
[ssl_ip_2 | host_name_2]
```

TABLE 4-7 describes the parameters for adding SSL blade configurations.

TABLE 4-7 Variables for Adding SSL Blade Configurations

Variable	Description
<i>ssl_blade_name</i>	Name of the SSL blade entry.
<i>ssl_ip_1</i>	IP address of the SSL blade on one interface.
<i>host_name_1</i>	Host name of the SSL blade on the same interface.
<i>ssl_ip_2</i>	(Optional) IP address of the SSL blade on the other interface.
<i>host_name_2</i>	(Optional) Host name of the SSL blade on the same interface.

▼ To Remove an SSL Blade

The `remove ssl name` command removes an SSL blade entry.

- **As admin in config mode, enter the `remove ssl name` command and the parameters:**

```
puma(config){admin}# remove ssl name ssl_blade_name
```

▼ To Add a Port Pair to an SSL Blade Entry

- As admin in config mode, enter the following command:

```
puma(config){admin}# ssl port-pair ssl_blade_name secureport  
secure_port_num clearport clear_port_num
```

The `ssl port-pair` command configures an SSL blade entry with a secure port and the corresponding clear port, that is, a port pair configuration.

Note – A maximum of four such port pairs can be added to an SSL blade entry. Each of the eight ports must be unique. Maximum value of each port is 1024.

TABLE 4-8 describes the parameters for adding and removing port pairs.

TABLE 4-8 Parameters for Adding and Removing Port Pairs

Parameter	Description
<i>ssl_blade_name</i>	Name of the SSL blade entry.
<code>secureport</code>	Qualifier for the secure port.
<i>secure_port_num</i>	The secure port number. This is the port at which a secure service configured with this SSL blade accepts SSL encrypted traffic from the client.
<code>clearport</code>	Qualifier for the clear port.
<i>clear_port_num</i>	The clear port number. This is the port to which this SSL blade sends the traffic after decryption.

▼ To Remove a Port Pair from an SSL Blade Entry

- As admin in config mode, enter the following command:

```
puma(config){admin}# remove ssl port-pair ssl_blade_name secureport  
secure_port_num clearport clear_port_num
```

The `remove ssl port-pair` command removes a port pair configuration from an SSL blade entry.

Note – If the SSL blade has either of its interfaces included in any service, then this command fails.

▼ To Add an Interface to an SSL Blade Entry

- As admin in config mode, enter the following command:

```
puma(config){admin}# ssl if ssl_blade_name {ssl_ip|host_name}
```

The `ssl if` command configures an interface for an SSL blade entry.

Note – A maximum of two interfaces can be configured for an SSL blade entry at any time.

TABLE 4-9 describes the variables for adding or removing an interface.

TABLE 4-9 Variables for Adding or Removing an SSL Blade Interface

Parameter	Description
<i>ssl_blade_name</i>	Name of the SSL blade entry.
<i>ssl_ip</i>	The IP address of the SSL blade interface.
<i>host_name</i>	The host name of the SSL blade interface.

▼ To Remove an Interface from an SSL Blade Entry

- As admin in config mode, enter the following command:

```
puma(config){admin}# remove ssl if ssl_blade_name {ssl_ip|host_name}
```

The `remove ssl if` command removes an interface from an SSL blade entry.

Note – An SSL blade entry must have at least one interface configured. It is not possible to remove an interface that is included in one or more services.

▼ To Enable an SSL Blade Entry

The `enable ssl name` command enables an SSL blade entry.

- **As admin in config mode, enter the `enable ssl name` command:**

```
puma(config){admin}# enable ssl name ssl_blade_name
```

By default, an SSL entry is enabled when it is created.

▼ To Disable an SSL Blade Entry

The `no enable ssl name` command disables an SSL blade entry.

- **As admin in config mode, enter the `no enable ssl name` command:**

```
puma(config){admin}# no enable ssl name ssl_blade_name
```

▼ To Show the Configured SSL Blades

- **As any user, enter the `show ssl` command:**

```
B10n {user} # show ssl [ssl_blade_name]
```

You can use this command to display the SSL blades configured for the content load balancing blade. By specifying the `ssl_blade_name`, you can show one specific blade.

Configuring the Content Load Balancing Blade

For Layer 7 load balancing, some TCP parameters must be configured on the content load balancing blade. The TCP stack in each of the blade servers being load balanced must be configured with the same parameters.

Note – For each of these parameters, the content load balancing blade starts up with a set of defaults that match those on the servers at the time of deployment.

▼ To Set the TCP Parameters

The `config default tcp-params` command sets the TCP parameters on the content load balancing blade to be used for TCP connections that are Layer 7 load balanced. These parameters must be set for each blade and serve as defaults. They can be overwritten for each individual service if required.)

- **As admin in config mode, set the default TCP parameters.:**

```
puma(config){admin}# default tcp-params [window tcp_window] [window-scale
tcp_ws_factor] [ts] [sack]
```

The following example sets the TCP default window to 2048, the window scaling factor to 1, and the TCP timestamp and SACK options:

```
puma(config){admin}# default tcp-params window 2048 window-scale 1 ts sack
```

TABLE 4-10 describes the options for setting the TCP parameters for the content load balancing blade.

TABLE 4-10 Options for Setting the TCP Parameters

Parameter	Description
window	(Optional) Qualifier for the value specified in the <code>tcp_window</code> argument.
<i>tcp_window</i>	(Optional) The TCP window size to use in the SYN.
window-scale	(Optional) Qualifier for the value specified in the <code>tcp_ws_factor</code> argument.
<i>tcp_ws_factor</i>	(Optional) The TCP window scaling factor to advertise in the SYN.
ts	(Optional) TCP timestamp option is supported.
sack	(Optional) TCP SACK option is supported.

Defaults

`tcp_window` defaults to 8192. `tcp_ws_factor` defaults to 0, that is, the window scaling option is not supported. The SACK option is supported by default, but the timestamp option is not.

Examples

The first example sets the TCP window to 2048:

```
puma(config){admin}# default tcp-params window 2048
```

The following example scales the window to 1 and includes the timestamp option:

```
puma(config){admin}# default tcp-params window-scale 1 ts
```

The third example adds only the timestamp and SACK options:

```
puma(config){admin}# default tcp-params ts sack
```

▼ To Set Parameters for TCP Connection Handoff

For TCP load balancing services, the Sun Fire B10n content load balancing blade performs a connection handoff to the back end servers. The maximum number of times the handoff message is to be retransmitted to a server before trying a new server is a parameter that is set to a default value on the content load balancing blade. The default can be changed as needed.

The default `tcp-handoff-params` command sets the default TCP connection handoff parameters on the content load balancing blade. These parameters are set for each blade and serve as defaults. They can be overwritten for a service if required.

- **As admin in config mode, set the default TCP handoff parameters:**

```
puma(config){admin}# default tcp-handoff-params max-open-resend
```

Where *max_open_resends* is the maximum number of times the OPEN message is retransmitted to the same server before load balancing again. The default value for *max_open_resends* is 5.

Example

The following example sets the value for the maximum retransmissions of the handoff message.

```
puma(config){admin}# default tcp-handoff-params 7
```

▼ To Show All the Default TCP Parameters Settings

- **As any user, enter the `show default tcp` command:**

```
B10n {user} # show default tcp
```

The `show default tcp` command shows default TCP parameters, TCP DoS defense parameters, and TCP connection handoff parameters configured on the content load balancing blade.

Load Balancing Service Configuration and Management

A load balancing service on Sun Fire B10n content load balancing blade is characterized by a VIP, a port, and a protocol, the interface on content load balancing blade to which the service is bound, SSL support, the load balancing layer and, if applicable, the load balancing protocol. Other configurations can be added incrementally to a service.

Creating a Load Balancing Service

The `service` command creates an entry for a load balancing service on the blade. Once you have created the service, you can add more configurations to it as needed.

Note that before a created service can be functional, a minimum of two commands must be executed for the service. First, a default group of servers and a load balancing scheme must be specified by using the `config service lb-group default` command. Second, the service (which is created in a disabled state) must be enabled by the `enable service` command.

For rule-based load balancing, the service must be linked to one or more blade servers, a load balancing scheme, and optionally, a load balancing rule by the `config service lb-group` command.

▼ To Create a Load Balancing Service

- As admin in config mode, create the load balancing service, using the parameters needed:

```
puma(config){admin}# service name service_name vip {vip_addr /  
host_name}:port_num:{tcp|udp} [ssl ssl_port_num] interface {0|1} [lb-layer {4|7}] [L7-proto  
{http|ftp}]
```

TABLE 4-11 describes the parameters for creating a load balancing service.

TABLE 4-11 Parameters for Creating a Load Balancing Service

Parameter	Description
<code>service_name</code>	Qualifier for the service name.
<i>service_name</i>	Configured name of the service (ASCII string).
<code>vip</code>	Qualifier for the virtual service address.
<i>vip_addr</i>	Destination IP address for the service.
<i>host_name</i>	Destination host name for the service.
<code>port_num</code>	Destination TCP/UDP port number for the service.
<code>tcp</code>	The Layer 4 protocol is TCP.
<code>udp</code>	The Layer 4 protocol is UDP.
<code>ssl</code>	(Optional) Specifies this service end point as an SSL end point.
<i>ssl_port_num</i>	(Optional) Specifies the decrypted port number for traffic coming back from the SSL blade. The maximum allowed value is 1024.
<code>interface</code>	Uses the value specified in the following argument.
0	This service point is bound to network interface number 0 on the content load balancing blade.
1	This service point is bound to network interface number 1 on the content load balancing blade.
<code>lb-layer</code>	(Optional) Qualifier for the OSI layer at which load balancing is to be performed.
4	Load balancing is performed based on the Layer 4 fields of the incoming packets.
7	Load balancing is performed based on the Layer 7 fields of the incoming packets.
<code>L7-proto</code>	(Optional) Qualifier for the protocol that is Layer 7 load balanced.
http	The Layer 7 protocol to be load balanced is HTTP.
ftp	The Layer 7 protocol to be load balanced is FTP.

Defaults

The default load balancing is at Layer 4. The default Layer 7 protocol is HTTP.

Examples

The first example creates a service named SVC0, with a VIP of 192.50.50.1, on port 80, using the TCP scheme. SVC0 is a Layer 4 load balanced TCP service.

```
puma(config){admin}# service name SVC0 vip 192.50.50.1:80:tcp
interface 0
```

The second example, creates a service named svc2, which is a Layer 4 load balanced SSL service bound to interface 0 of the content load balancing blade. The SSL decrypted port is 880.

```
puma(config){admin}# service name svc2 vip 192.50.50.1:443:tcp ssl
880 interface 0
```

The last example creates a service named SVC1, which is a Layer 7 load balanced HTTP service.

```
puma(config){admin}# service name SVC1 vip 192.50.50.1:8080:tcp
interface 1 lb-layer 7 L7-proto http
```

▼ To Add SSL Devices to a Service

The `service ssl` command adds one or more SSL devices to the SSL load balancing group of a service.

- As admin in config mode, type the following command, using the parameters needed:

```
puma(config){admin}# service ssl service_name ssl ssl_blade_name:{active|standby}
[ssl_blade_name:{active|standby}....]
```

TABLE 4-12 describes the parameters for adding one or more SSL devices to the SSL load balancing group of a service.

TABLE 4-12 Parameters for Adding SSL Devices to a Service

Parameter	Description
<i>service_name</i>	Name of the load balancing service.
<i>ssl</i>	Qualifier for the SSL blade argument.
<i>ssl_blade_name</i>	Name of the SSL proxy blade.
<i>active</i>	The SSL proxy blade is added in the active mode.
<i>standby</i>	The SSL proxy blade is added in the standby mode.

Usage Guidelines

The `service ssl` command should be invoked at least once for any service that has one or more end points enabled for SSL.

▼ To Remove SSL Devices from a Service

- **As admin in config mode, type the following command, using the parameters needed:**

```
puma(config){admin}# remove service ssl service_name ssl ssl_blade_name [ssl_blade_name]
```

This command removes one or more SSL devices from the SSL load balancing group of a service.

TABLE 4-13 describes the parameters for removing one or more SSL devices from the SSL load balancing group of a service.

TABLE 4-13 Parameters for Removing SSL Devices from a Service

Parameter	Description
<i>service_name</i>	Name of the load balancing service.
<i>ssl</i>	Qualifier for the SSL blade argument.
<i>ssl_blade_name</i>	Name of the SSL proxy blade.

▼ To Set SSL Devices in a Service as Active or Standby

- As admin in config mode, type the following command, using the parameters needed:

```
puma(config){admin}# modify service ssl mode service_name ssl ssl_blade_name  
[ssl_blade_name...] mode {active|standby}
```

This command sets one or more SSL devices in the SSL load balancing group of a service as either active or standby.

TABLE 4-12 describes the parameters for modifying one or more SSL devices in the SSL load balancing group of a service as either active or standby.

TABLE 4-14 Parameters for Modifying SSL Devices in a Service

Parameter	Description
<i>service_name</i>	Name of the load balancing service.
<i>ssl</i>	Qualifier for the SSL blade argument.
<i>ssl_blade_name</i>	Name of the SSL proxy blade.
<i>mode</i>	Qualifier for the device mode.
<i>active</i>	Set the device as active for the service.
<i>standby</i>	Set the device as standby for the service.

▼ To Add a Default Load Balancing Group to a Load Balancing Service

- As admin in config mode, type the `service lb-group default` command, using the parameters needed:

```
puma(config){admin}# service lb-group default service_name server {ip_addr |  
host_name}:port:protocol:weight:active [ {ip_addr | host_name}:port:protocol:weight:active... ] [ scheme {round-  
robin | wt-round-robin | static}]
```

The service `lb-group default` command configures one or more servers to which a request for a service is directed if it does not match any of the rules in any of the load balancing groups configured for that service. The load balancing scheme is also configured. This is the default load balancing group for the service. All the load balancing group commands can be applied to this group with the load balancing group name specified as the default.

TABLE 4-15 describes the parameters for adding a default load balancing group to a load balancing service.

TABLE 4-15 Parameters for Adding a Default Load Balancing Group to a Service

Parameter	Description
<i>service_name</i>	Name of the load balancing service.
<i>server</i>	Qualifier for the server or real service argument.
<i>ip_addr</i>	IP address of the back end server.
<i>host_name</i>	Host name of the back end server.
<i>port</i>	Port on the back end server where this service can be provided. If specified as 0, it means that this is just a server and not a real service protocol.
<i>protocol</i>	Corresponding protocol on the back end server.
<i>weight</i>	Weight for this blade server. Valid only if the load balancing scheme used is weighted round robin. Otherwise, this is ignored.
<i>active</i>	Specifies the blade server as active for this load balancing group if the value is 1, standby if the value is 0.
<i>scheme</i>	(Optional) Qualifier for the load balancing scheme.
<i>round-robin</i>	(Optional) Load balancing scheme is round robin.
<i>wt-roundrobin</i>	(Optional) Load balancing scheme is weighted round robin.
<i>static</i>	(Optional) Load balancing scheme is static load balanced, where the server is chosen by a hash function. Used when the service is configured for UDP.

Note – Port NAT is not supported at this time. So the *port* and *protocol* field values are ignored.

Defaults

The default load balancing scheme is round robin for a TCP service. When the load balancing scheme is weighted round robin and the weight is specified as 0 for a server, then the default weight is 1. For round robin and static load balancing schemes the weight field is ignored.

Usage Guidelines

Invoke this command at least once for any service after the service is created and before it starts accepting connections.

For a UDP service, the only load balancing scheme supported is static.

Examples

The first example uses the default scheme and only one server.

```
puma(config){admin}# service lb-group default SVC1 server
192.50.50.201:0:tcp:5:1
```

The following example sets three servers, uses the TCP protocol, and specifies the scheme as weighted round robin.

```
puma(config){admin}# service lb-group default SVC1 server
192.50.50.201:0:tcp:5:0 192.50.50.202:0:tcp:10:1
192.50.50.203:0:tcp:7:1 scheme wt-round-robin
```

▼ To Set the TCP Parameters for a Service

- As admin in config mode, enter the `service tcp-params` command, using the TCP parameters for a service:

```
puma(config){admin}# service tcp-params service_name [window tcp_window] [window-
scale tcp_ws_factor] [ts] [sack]
```

TABLE 4-16 describes the TCP parameters to set for a service.

TABLE 4-16 TCP, Parameters for a Service

Parameter	Description
<i>service_name</i>	The name of the service to set the TCP parameters.
<i>window</i>	Qualifier for the value specified in the <i>tcp_window</i> argument.
<i>tcp_window</i>	The TCP window size to use in the SYN.
<i>window-scale</i>	(Optional) Qualifier for the value specified in the <i>tcp_ws_factor</i> argument.
<i>tcp_ws_factor</i>	(Optional) The TCP window scaling factor to advertise in the SYN.
<i>ts</i>	(Optional) TCP timestamp option is supported.
<i>sack</i>	(Optional) TCP SACK option is supported.

The `service tcp-params` command overwrites the default TCP settings on the load balancer and is valid only if the protocol for the service is TCP and the load balancing is done at Layer 7.

For most cases, use the TCP parameters set by the `config default tcp-params` command for each content load balancing blade since those are the parameters with which all the back end servers served by the content load balancing blade are configured. If this command is invoked for any service to change these defaults, the network administrator must modify the TCP parameters of the servers accordingly. But if any one of these servers is included in another service with different TCP parameters, then this command fails.

Defaults are the values configured for the content load balancing blade.

Usage Guidelines

For most cases, the TCP parameters set by the `default tcp-params` command on each content load balancing blade should be used. Those are the parameters with which all the back end servers served by the content load balancing blade are configured. If this command is invoked at all for any service to change these defaults, the network administrator should ensure that the servers added to this service have their TCP parameters modified accordingly. But if any one of these servers is included in another service with different TCP parameters, then this command fails.

Example

```
puma(config){admin}# service tcp-params SVC1 window 2048 window-  
scale 1 ts
```

▼ To Set Parameters for TCP Connection Handoff for a Service

The `service tcp-handoff-params` command modifies the default TCP connection handoff parameters for a service. This command is valid only if the protocol for the service is TCP.

- As admin in config mode, enter the `service tcp-handoff-params` command:

```
puma(config){admin}# service tcp-handoff-params service_name max-open  
max_open_resends
```

Where:

service_name is the name of the service

max_open uses the value specified in the *max_open_resends* argument.

max_open_resends is the maximum number of times the OPEN message is retransmitted to the same server before load balancing again.

Defaults

The default is the same as that set for the content load balancing blade.

Example

The following example sets the maximum number of times the OPEN message is retransmitted to the same server before load balancing again to four times for the service SVC1.

```
puma(config){admin}# service tcp-handoff-params SVC1 max-open 4
```

▼ To Add a Service Point to a Service

The `service point` command adds one or more IP address, port, and protocol combinations to a given service, making the service multihomed.

If the VIP is already bound to an interface in any service, be sure to specify that interface. Two service end points on a given service cannot have the same VIP. The protocol for every added end point should be the same as the service protocol.

- **As admin in config mode, enter the `service point` command:**

```
puma(config){admin}# service point service_name point ip_addr |  
host_name:port_num:proto:ssl:ssl_port_number:interface [ip_addr | host_name:port_num:proto:ssl:  
ssl_port_number:interface...]
```

TABLE 4-17 describes the service point parameters available for a service.

TABLE 4-17 Service Point Parameters

Parameter	Description
<i>service_name</i>	Name of the service.
<i>point</i>	Qualifier for the service point.
<i>ip_addr</i>	IP address of the service point.
<i>host_name</i>	Host name of the service point.
<i>port_num</i>	Corresponding port number of the service point.
<i>proto</i>	Corresponding protocol of the service point: TCP or UDP.
<i>ssl</i>	If 1, specifies the added service end point as SSL enabled, if 0, no SSL support provided for service point.
<i>ssl_port_num</i>	The decrypted port number to which the traffic from the SSL blade is destined. Maximum allowed value is 1024.
<i>interface</i>	Specifies the interface on the content load balancing blade on which this service point is bound. Can have the following values: 0: The service point bound to network interface number 0 on a content load balancing blade. 1: The service point bound to network interface number 1 on a content load balancing blade.

Note – A maximum of three end points are allowed for each service. This includes the end point with which the service was created.

Examples

The first example adds two service points to the service SVC1, both using TCP protocol, on port 80, with no SSL support.

```
puma(config){admin}# service point SVC1 point
192.50.51.1:80:tcp:0:0:0 192.50.51.2:80:tcp:0:0:0
```

The following example adds one service point to the service svc2 on interface 0, port 80, protocol TCP, with SSL support and the decrypted port specified as 880.

```
puma(config){admin}# service point svc2 point
192.50.51.3:80:tcp:1:880:0
```

▼ To Remove a Service Point From a Service

The `remove service point` command removes one or more service points from a given service.

- **As admin in config mode, enter the `remove service point` command:**

```
puma(config){admin}# remove service point service_name point {ip_addr |
host_name}:port_num:proto [{ip_addr | host_name}:port_num:proto...]
```

TABLE 4-18 describes the service point parameters to be removed from a service

TABLE 4-18 Service Point Parameters

Parameter	Description
<i>service_name</i>	Name of the service.
<i>point</i>	Qualifier for the service point.
<i>ip_addr</i>	IP address of the service point.

TABLE 4-18 Service Point Parameters

Parameter	Description
<i>host_name</i>	Host name of the service point.
<i>port_num</i>	Corresponding port number of the service point.
<i>proto</i>	Corresponding protocol of the service point.

Example

This example removes a service point with VIP 192.50.51.1, port 80, and protocol TCP from the service SVC1.

```
puma(config){admin}# remove service point SVC1 point 192.50.51.1:80:tcp
```

▼ To Configure a Service for Client IP or Subnet-Based Persistence

The `service ip-persist` command configures a service for persistence based on the client IP address or subnet.

If configured for client IP persistence, all traffic to this service coming from the same client IP (or same subnet in case a mask is specified) is sent to the same back end server. The timer specifies the inactivity interval after which this persistence ceases to exist, that is, subsequent traffic from the same client IP (or subnet) to this service is load balanced to another blade server.

- **As admin in config mode, enter the `service ip-persist` command:**

```
puma(config){admin}# service ip-persist service_name [mask mask_len] [timeout timeout_val]
```

TABLE 4-19 describes the parameters for configuring a service for persistence.

TABLE 4-19 Parameters for Configuring a Service for Persistence

Parameter	Description
<code>service_name</code>	The name of the service entry to be configured for client IP persistence.
<code>mask</code>	(Optional) The client IP mask used for persistence.
<code>mask_len</code>	(Optional) The number of bits to be masked from the right. The valid range is 0 to 31.
<code>timeout</code>	(Optional) Uses the value specified in the <code>timeout_val</code> argument.
<code>timeout_val</code>	(Optional) The inactivity time (in minutes) after which a persistence is removed. The valid range is 0 to 1092.

Defaults

The default behavior is IP persistence for a specific client IP (when a subnet is not specified, that is, `mask_len = 0`). The default timeout value is the same as that configured for service point tracking if such a configuration exists, otherwise the timeout is five minutes.

Examples

The first example sets service IP persistence for the service named SVC1.

```
puma(config){admin}# service ip-persist SVC1
```

The following example sets service IP persistence for the service named SVC1 using mask 16 and a timeout of 10 minutes.

```
puma(config){admin}# service ip-persist SVC1 mask 16 timeout 10
```

▼ To Remove Client IP or Subnet Based Persistence from a Service

When client IP persistence is removed from a service, then any new connections to the service are load balanced again.

- **As admin in config mode, enter the `no service ip-persist` command:**

```
puma(config){admin}# no service ip-persist service_name
```

Example

```
puma(config){admin}# no service ip-persist SVC1
```

Configuring a Service for Service Point Tracking

The `service tracking` command configures a service for tracking one or more service points with or without the destination VIPs specified.

If configured for service point tracking, all traffic to this service coming from the same client IP and destined to any of the tracking service points specified in the configuration is sent to the same back end server. The timer specifies the inactivity interval after which this persistence ceases to exist, that is, subsequent traffic from the same client IP, destined to any of the tracking service points configured is load balanced to another back end server. Service point tracking is a special case of client IP-based persistence.

Note – The timeout value may overwrite the one specified by the `config service ip-persist` command if that has been already invoked for this service as only one persistence timer is maintained for each service.

In case the VIP to track is not specified (that is, specified as 0), the service performs port tracking on the specified service points.

Note – End point tracking is added only to the primary VIP, that is, the VIP end point with which the service was created. Port tracking is added to all the VIP end points of a multihomed service.

Note – The maximum number of service points that can be added for tracking is five.

▼ To Configure a Service for Service Point Tracking

- As admin in config mode, enter the `service tracking` command:

```
puma(config){admin}# service tracking service_name track {vip_addr | host_name}:port:proto
[vip_addr | host_name]:port:proto] timeout timeout_val
```

TABLE 4-20 describes the parameters for configuring a service for service point tracking.

TABLE 4-20 Parameters for Configuring a Service for Tracking

Parameter	Description
<code>service_name</code>	Name of the service entry to be configured for service point tracking.
<code>track</code>	Qualifies the service point that should track the primary service point.
<i>vip_addr</i>	VIP address of the service point to track the primary. If 0, then only the port (and protocol) is tracked.
<i>host_name</i>	Host name of the service point to track the primary. If 0, then only the port (and protocol) is tracked.
<i>port</i>	Port number of the service point to track the primary.
<i>proto</i>	Protocol of the service point to track the primary.
<code>timeout</code>	(Optional) Uses the value specified in the <i>timeout_val</i> argument.
<i>timeout_val</i>	(Optional) The inactivity time (in minutes) after which tracking stops.

Defaults

The default behavior is port tracking on the specified service points (when the VIP is specified as 0). The default timeout value is the same as that configured for client IP persistence if such a configuration exists, else five minutes.

Examples

The first example sets port tracking for the service named SVC1, at port 443, using the TCP protocol.

```
puma(config){admin}# service tracking SVC1 track 0:443:tcp
```

The following example sets end point tracking entries for the service named SVC1: One tracking end point is given by VIP 188.88.8.1, port 9090, protocol TCP. The other end point has VIP 177.77.7.1. port 80, using the TCP protocol.

```
puma(config){admin}# service tracking SVC1 track  
188.88.8.1:9090:tcp 177.77.7.1:80:tcp timeout 20
```

▼ To Remove Tracking Service Point from a Service

- **As admin in config mode, enter the `remove service tracking` command:**

```
puma(config){admin}# remove service tracking service_name track {vip_addr |  
host_name}:port:proto
```

This command removes a tracking service point from a service. See TABLE 4-20 for descriptions of the parameters.

Examples

The first example removes port tracking for the service named SVC1, at port 443, using the TCP protocol.

```
puma(config){admin}# remove service tracking SVC1 track 0:443:tcp
```

The following example removes two end point tracking end points from the service SVC1.

```
puma(config){admin}# remove service tracking SVC1 track  
188.88.8.1:9090:tcp 177.77.7.1:80:tcp
```

▼ To Configure a Service for Cookie-Based Persistence

The purpose of the `service cookie-persist` command is to handle cookies embedded in a packet and ensure persistence across connections for an application offered by a particular blade server in this service.

1. As admin in config mode, enter the following command:

```
puma(config){admin}# service cookie-persist service_name cookie
cookie_name offset offset_len delim delimiter_character
```

2. Enter the `build rules` command:

```
puma(config){admin}# build rules
```

Note – Don't run traffic to this service yet, wait for the build to return with completion status.

3. Check the build status:

```
puma(config){admin}# show build status
```

When the build is completed, the completion message is printed out. Then you can run traffic to this service.

TABLE 4-21 describes the parameters for configuring a service for cookie-based persistence.

TABLE 4-21 Parameters for Configuring a Service for Cookie-Based Persistence

Parameter	Description
<code>service_name</code>	Name of the service entry to be configured for cookie persistence.
<code>cookie</code>	Qualifies the cookie name.
<code>cookie_name</code>	Name of the cookie on which the persistence is enforced.
<code>offset</code>	Qualifies the offset.

TABLE 4-21 Parameters for Configuring a Service for Cookie-Based Persistence

Parameter	Description
<i>offset_len</i>	Number of characters/bytes from the start of the cookie value from which the server name string begins.
<i>delim</i>	Qualifies the delimiter.
<i>delimiter_character</i>	Character used as delimiter to mark the end of the server name string. The only currently available character is a colon (:).

Example

The following example sets the service for cookie-based persistence for the service named SVC1, for the cookie named Car, the offset length is set for 10 and the delimiter character is a colon.

```
puma(config){admin}# service cookie-persist SVC1 cookie Car offset  
10 delim :
```

▼ To Remove Cookie Persistence From a Service

The `remove service cookie-persist` command removes cookie based persistence from a service for a specific cookie name.

- **As admin in config mode, enter the following command.**

```
puma(config){admin}# remove service cookie-persist service_name  
cookie_name
```

Where *service_name* is the name of the service entry and *cookie_name* is the name of the cookie.

Example

The following example removes the service for cookie-based persistence for the service named SVC1, for the cookie named Car:

```
puma(config){admin}# remove service cookie-persist SVC1 cookie Car
```

▼ To Enable a Load Balancing Service

When a service is created, it is disabled by default. For the service to accept traffic, it must be enabled by invoking the `enable service` command. When a service is enabled, all the load balancing groups it contains get enabled too.

Note – This command fails if the default load balancing group for the service is not configured with at least one active backend server. For an SSL service, this command fails if the service is not configured with at least one active SSL blade. For an FTP service, this command fails if the service is not configured with IP persistence.

- **As admin in config mode, enter the following command.**

```
puma(config){admin}# enable service name service_name
```

Where *service_name* is the name of the service to be enabled.

Example

The following example enables the service named SVC1.

```
puma(config){admin}# enable service name SVC1
```

▼ To Disable a Load Balancing Service

The `no enable service` command disables a specified load balancing service. When a service is disabled, all the load balancing groups it contains are disabled. By default all services are disabled upon creation.

- **As admin in config mode, enter the `no enable service` command.**

```
puma(config){admin}# no enable service name service_name
```

Where *service_name* is the name of the service to be disabled.

▼ To Remove a Load Balancing Service

The `remove service name` command removes one or more load balancing services.

- **As admin, enter the `remove service name` command.**

```
puma(config){admin}# remove service name service_name
```

Where *service_name* is the name of the service to be removed.

Examples

The first example removes one service named SVC1.

```
puma(config){admin}# remove service name SVC1
```

The following example removes two services: SVC1 and svc2.

```
puma(config){admin}# remove service name SVC1 svc2
```

Server Configuration

▼ To Enable a Server

The `enable server` command enables a specific back end server on all services or on a specified service. By default the server is enabled on all services.

- **As admin in config mode, enter the `enable server` command:**

```
puma(config){admin}# enable server {ip_addr | host_name} [service
service_name]
```

TABLE 4-22 describes the parameters for enabling a server.

TABLE 4-22 Parameters for Enabling or Disabling a Server

Parameter	Description
<i>ip_addr</i>	Server IP address.
<i>host_name</i>	Server host name.
<i>service</i>	Qualifier for the service name.
<i>service_name</i>	Name of the load balancing service on which the back end server is enabled or disabled.

Examples

The first example enables the server at the IP address of 192.50.50.201 in all services.

```
puma(config){admin}# enable server 192.50.50.201
```

The following example enables the server at the IP address of 192.50.50.201 in the service SVC1.

```
puma(config){admin}# enable server 192.50.50.201 service SVC1
```

▼ To Disable a Server

The `no enable server` command disables a specific back end server on all services or on a specified service. By default, the server is enabled on all services.

Note – If the server is the only active server on any load balancing group, then any subsequent traffic to that server is still sent to the server instead of being dropped.

If the server is the only one in any load balancing group, then this command fails.

- **As admin, enter the no enable server command:**

```
{puma(config){admin}# no enable server {ip_addr | host_name} [service  
service_name]
```

Examples

The first example disables the server at the IP address of 192.50.50.201 in all services.

```
puma(config){admin}# no enable server 192.50.50.201
```

The following example disables the server at the IP address of 192.50.50.201 in the service SVC1.

```
puma(config){admin}# no enable server 192.50.50.201 service SVC1
```

Load Balancing Rule Configuration

Creating an IP Load Balancing Rule

The `config ip-rule` command creates a load balancing rule for IP traffic. By default, the rule has low priority.

An IP rule with a high priority gets a higher priority for a given service than IP rules specified with low priority or no priority. When an IP rule is used in conjunction with Layer 7 rules such as HTTP rules in a service, then a high priority puts it at a priority higher than static URLs and a low priority puts it at a priority lower than dynamic URLs. Within multiple IP rules of the same priority class (that is, high or low), the relative priority is determined by the number of bits specified in the IP address and port masks, that is, fewer number of bits masked out results in a higher priority.

Note – The configured rule name must be unique across all types of rules (IP rules, HTTP rules, and so on).

▼ To Create an IP Load Balancing Rule

- As admin in config mode, enter the `ip-rule` command:

```
puma(config){admin}# ip-rule name rule ip_addr:port mask ip_addr_mask:port_mask priority  
[ {high | low} ]
```

TABLE 4-23 describes the parameters for creating an IP load balancing rule.

TABLE 4-23 Parameters for Creating an IP Load Balancing Rule

Parameter	Description
<i>name</i>	Name of the IP rule created.
<i>rule</i>	Uses the value specified in the <i>ip_addr:port</i> argument.
<i>ip_addr</i>	Source IP address to be matched, for example., 172.88.8.1.
<i>port</i>	Source port to be matched, for example, 21.
<i>mask</i>	Uses the value specified in the <i>ip_addr_mask:port_mask</i> argument.
<i>ip_addr_mask</i>	Source IP address mask to be used for lookup, for example, 255.255.0.0.
<i>port_mask</i>	Source port mask to be used for lookup, for example 0 (for masked) or 1 (specified).
<i>priority</i>	(Optional) Qualifier for the rule priority.
<i>high</i>	(Optional) Specifies the priority of an IP rule as high.
<i>low</i>	(Optional) Specifies the priority of an IP rule as low.

Examples

The first example adds an IP rule named IPRule1 and sets the priority at high.

```
puma(config){admin}# ip-rule IPRule1 rule 172.88.8.1:21 mask  
255.255.255.0:1 priority high
```

The following example adds ip-rule IPRule2 and uses the default priority.

```
puma(config){admin}# ip-rule IPRule2 rule 172.88.8.1:3241 mask
255.255.0.0:0
```

Creating an HTTP Load Balancing Rule

The config `http-rule` command creates a load balancing rule for HTTP traffic.

Depending on the rule type, the HTTP rules are assigned different priority classes within a service. Listed in order of decreasing priority, these classes are, static URL, cookie, CGI, and dynamic URLs. Within a particular priority class, individual rules are further prioritized based on the actual rule string, for example, a fully specified rule has a higher priority than a rule with wildcards.

Note – The configured rule name must be unique across all types of rules (IP rules, HTTP rules and such).

▼ To Create an HTTP Load Balancing Rule

- As admin in config mode, enter the `http-rule` command:

```
puma(config){admin}# http-rule name {static | dynamic | cgi | cookie} string rule_string
```

TABLE 4-24 describes the parameters for creating an HTTP load balancing rule.

TABLE 4-24 Parameters for Creating an HTTP Load Balancing Rule

Parameter	Description
<i>name</i>	Name of the HTTP rule created.
<i>static</i>	Rule is of the static URL type.
<i>dynamic</i>	Rule is of the dynamic URL type.
<i>cgi</i>	Rule is CGI based.
<i>cookie</i>	Rule is cookie-based.
<i>string</i>	Uses the value specified in the <i>rule_string</i> argument.
<i>rule_string</i>	Actual rule string. For example, *.gif can be the rule for a static URL type. The length of the string is restricted to 256 bytes.

Examples

The first example adds an HTTP rule named `HttpR1` of the static URL type with a `*.gif` *rule_string*.

```
puma(config){admin}# http-rule HttpR1 static string *.gif
```

The following example adds the HTTP rule `HttpCgiR1`, which is CGI-based with `server=server1` as the *rule_string*.

```
puma(config){admin}# http-rule HttpCgiR1 cgi string server=server1
```

The final example adds the HTTP rule `HttpCookieR1`, which is cookie-based with a `server=server2` as the *rule_string*.

```
puma(config){admin}# http-rule HttpCookieR1 cookie string server=server2
```

▼ To Remove a Load Balancing Rule

The `remove rule` command removes one or more a load balancing rules of any type, including IP, HTTP, and others.

If the rule is part of one or more load balancing groups, it cannot be removed.

- **As admin in config mode, enter the `remove rule` command:**

```
puma(config){admin}# remove rule rule_name [rule_name.....]
```

Where `rule_name` is the name of the load balancing rule to be removed.

Examples

The following example removes the rules `HttpR1` and `HttpCgiR1` from the system:

```
puma(config){admin}# remove rule HttpR1 HttpCgiR1
```

▼ To Build Load Balancing Rules

The `build rules` command creates a new build for the load balancing rules on the content load balancing blade. This command must be invoked before any modifications made to rules associated with load balancing groups can take effect.

Note – You cannot add, modify, or delete configurations related to the service, lb-group, or rules while the rule building is in progress.

- **As admin in config mode, enter the `build rules` command:**

```
puma(config){admin}# build rules
```

Note – Even though the CLI for the command returns success immediately, the rules are built by a background task and do not take effect until that task reports successful completion. The status of this background build task can be queried with the `show build status` command.

▼ To Get the Status for the Build for Load Balancing Rules

The `show build status` command displays the status of the current build for the load balancing rules on the content load balancing blade.

- **As any user, enter the `show build status` command:**

```
puma{user}# show build status
```

▼ To Get the Status for the Last Build for Load Balancing Rules

The `show last build status` command displays the status of the last build for the load balancing rules on content load balancing blade.

- **As any user, enter the `show last build status` command:**

```
puma{user}# show last build status
```

▼ To Stop the Build for Load Balancing Rules

If a build is in progress, the `no build rules` command stops the current build for the load balancing rules on the content load balancing blade.

- **As admin in config mode, enter the `no build rules` command:**

```
puma(config){admin}# no build rules
```

Load Balancing Group Configuration and Management

Before a load balancing service can be functional, it must be associated with one or more blade servers, a load balancing scheme, and a load balancing rule. This association is called a load balancing group which is a complete functional unit required for load balancing with the Sun Fire B10n content load balancing blade.

▼ To Create a Default Load Balancing Group

- **As admin in config mode, create a default load balancing group:**

```
puma(config){admin}# service lb-group default service_name service server {ip_addr | host_name};port:protocol:weight:active [ {ip_addr | host_name};port:protocol:weight:active...] rule rule_name [scheme {round-robin | wt-round-robin | static}]
```

▼ To Create a Load Balancing Group

- As admin in config mode, create a load balancing group:

```
puma(config){admin}# service lb-group lb_group_name service service_name server
{ip_addr | host_name}:port:protocol:weight:active [ {ip_addr | host_name}:port:protocol:weight:active... ] rule
rule_name [scheme {round-robin | wt-round-robin | static}]
```

This command must be followed by the `build rules` command at the completion of which the new rule added becomes effective.

Whenever a service is created, a default load balancing group is associated with it. So, “default” is not an acceptable value for the group name as it is reserved for the default load balancing group.

An IP rule can be added to a Layer 4 service as well as a Layer 7 service, but HTTP rules can be added only to Layer 7 services.

If the service protocol is configured as UDP, then the only load balancing scheme allowed is static and only IP (Layer 4) rules can be associated with the service.

If the load balancing scheme is static or round-robin, then the weight field is ignored.

If you are configuring a service for UDP, the only load balancing scheme allowed is static.

Whenever a service is created, a default load balancing group is associated with it. See TABLE 4-25.

Note – While you can enter multiple commands in the CLI, no command can be longer than 255 characters. Hence, commands longer than that must be divided into as many commands as necessary to stay within the 255 character limitation.

For example, the following command would fail if you tried to enter it on one line:

```
puma(config){admin}# config service lb-group default lb4rr_8 server
192.168.101.2:6300:tcp:5:1 192.168.101.35:6300:tcp:5:1
192.168.101.4:6300:tcp:5:1 192.168.101.5:6300:tcp:5:1 1
92.168.101.33:6300:tcp:5:1 192.168.101.34:6300:tcp:5:1 scheme wt-round-robin
```

Examples

While the example shows the scheme being defined as weighted round robin, you might prefer some other scheme. Note that weighted round robin can be weighed either by server load or response time.

```
puma(config){admin}# service lb-group name GRP1 service SVC1 server
192.50.50.203:80:tcp:10:1 192.50.50.204:80:tcp:20:1 192.50.50.205:80:tcp:15:0
rule HttpR1 scheme wt-round-robin
```

TABLE 4-25 describes the parameters for creating load balancing groups.

TABLE 4-25 Parameters for Creating Load Balancing Groups

Parameter	Description
name	Qualifier for the LB group name.
<i>lb_group_name</i>	Name of this load balancing group.
service	Uses the value specified in the <i>service_name</i> argument.
<i>service_name</i>	Name of the service.
server	Qualifier for the back end server argument.
<i>ip_addr</i>	IP address of the back end server.
<i>host_name</i>	Host name of the back end server.
<i>port</i>	Port on the back end server where this service can be provided. If specified as 0, it means that this is just a server and not a real service.
<i>protocol</i>	Corresponding protocol on the back end server. If specified as 0, it means that this is just a server and not a real service.
<i>weight</i>	Weight for this blade server. Valid only if the load balancing scheme used is weighted round robin. Otherwise, specify as 0.
<i>active</i>	Specifies the blade server as active for this load balancing group if the value is 1, standby if the value is 0.
rule	Qualifier for the rule name argument.
<i>rule_name</i>	Name of the load balancing rule to be added to this LB group.
scheme	(Optional) Qualifier for the load balancing scheme.

TABLE 4-25 Parameters for Creating Load Balancing Groups (Continued)

Parameter	Description
<i>round-robin</i>	(Optional) Load balancing scheme is round robin.
<i>wt-round-robin</i>	(Optional) Load balancing scheme is weighted round robin.
<i>static</i>	(Optional) Load balancing scheme is static load balanced, where the server is chosen by a hash function. Used when the service is configured for UDP.

Note – Port NAT is not supported at this time. So the *port* and *protocol* field values are ignored.

▼ To Add Rules to a Load Balancing Group

- As admin in config mode, add a rule to a load balancing group:

```
puma(config){admin}# service lb-group rule service_name:lb_group_name rule rule_name  
[rule_name.....]
```

The `service lb-group rule` command adds one or more rules to a load balancing group. When a request matches this service, it is matched against all the rules linked with the service and if any rule matches the request, then it is load balanced to the servers configured for this load balancing group.

This command should be followed by the `build rules` at the completion of which the new rule(s) added becomes effective.

A rule (with a given content) can be added to a service only once, that is, it can appear only once in at most one load balancing group for a given service. Addition of duplicate rules to a service fails.

An IP rule can be added to a Layer 4 service as well as a Layer 7 service, but HTTP rules can be added only to Layer 7 services.

Note – This command cannot be used to add rules to the default group.

TABLE 4-26 describes the parameters for adding rules to a load balancing group.

TABLE 4-26 Parameters for Adding Rules to a Load Balancing Group

Parameter	Description
<i>service_name</i>	Name of the load balancing service to which this LB group belongs.
<i>lb_group_name</i>	Name of the load balancing group to which one or more rules are being added.
<i>rule</i>	Uses the value specified in the <i>rule_name</i> argument.
<i>rule_name</i>	Name of the rule to be added to this LB group.

Examples

The first example adds an HTTP cookie rule to SVC1 and GRP1.

```
puma(config){admin}# service lb-group rule SVC1:GRP1 rule HttpCookieR1
```

The following example adds a CGI rule to SVC1.

```
puma(config){admin}# service lb-group rule SVC1:GRP1 rule HttpCgiR1
```

▼ To Remove Rules From a Load Balancing Group

- As admin in config mode, remove a rule from a load balancing group:

```
puma(config){admin}# remove service lb-group rule service_name rule rule_name  
[rule_name.....]
```

The `remove service lb-group rule` command removes one or more rules from a load balancing group.

This command should be followed by a `build rules` command after the completion of which the rule removal becomes effective.

If the rule being removed from the load balancing group is the last rule present and the service is configured for Layer 7 load balancing, then this command fails.

Example

```
puma(config){admin}# remove service lb-group rule SVC1 rule
HttpCgiR1
```

▼ To Add Servers to a Load Balancing Group

- As admin in config mode, add a server to a load balancing group:

```
puma(config){admin}# service lb-group server service_name:lb_group_name server {ip_addr
| host_name}:port:protocol:weight:active [{ip_addr | host_name}:port:protocol:weight:active...]
```

The `service lb-group server` command adds one or more servers to a load balancing group.

If the load balancing scheme is weighted round robin and the weight is specified as 0 for a server, then the default weight is 1.

TABLE 4-27 describes the parameters for adding servers to a load balancing group.

TABLE 4-27 Parameters for Adding Servers to a LB Group

Parameter	Description
<i>service_name</i>	Name of the load balancing service to which this LB group belongs.
<i>lb_group_name</i>	Name of the load balancing group to which one or more server-port pairs are being added.
<i>server</i>	Qualifier for the blade server argument.
<i>ip_addr</i>	Server IP address.
<i>host_name</i>	Server host name.
<i>port</i>	Port on the back end server where this service can be provided.
<i>protocol</i>	Corresponding protocol on the blade server.
<i>weight</i>	Weight for this blade server. Valid only if the load balancing scheme used is weighted round robin. Otherwise, this is ignored.
<i>active</i>	Specifies the back end server as active for this load balancing service group if the value is 1, standby if the value is 0.

Note – Port NAT is not supported at this time. So the *port* and *protocol* field values are ignored.

Example

```
puma(config){admin}# service lb-group server SVC1:default server
192.50.50.210:80:10:1
```

▼ To Remove Servers From a Load Balancing Group

- As admin in config mode, remove a server from a load balancing group:

```
puma(config){admin}# remove service lb-group server service_name:lb_group_name server
{ip_addr | host_name}:port:protocol [{ip_addr | host_name}:port:protocol...]
```

The `remove service lb-group server` command removes one or more servers from a load balancing group.

If the server being removed from the load balancing group is the last one present, then this command fails.

TABLE 4-28 describes the parameters for removing servers from a load balancing group.

TABLE 4-28 Parameters for Removing Servers to a LB Group

Parameter	Description
<i>service_name</i>	Name of the load balancing service to which this LB group belongs.
<i>server</i>	Qualifier for the back end server argument.
<i>ip_addr</i>	Server IP address.
<i>host_name</i>	Server host name.
<i>port</i>	Port on the back end server where this service can be provided.
<i>protocol</i>	Corresponding protocol on the back end server.

Examples

The following example removes the service SVC1 from lb-group server with the IP address of 192.50.50.210 on port 80.

```
puma(config){admin}# remove service lb-group server SVC1:default
server 192.50.50.210:80
```

▼ To Set Servers for a Load Balancing Group as Active or Standby

- As admin in config mode, set a server for a load balancing group as active or standby:

```
puma(config){admin}# modify service lb-group server service_name:lb_group_name server
{ip_addr | host_name}:port:protocol [{ip_addr | host_name}:port:protocol...] mode {active|standby}
```

This command sets one or more servers for a load balancing group as active or standby.

Note – A load balancing group must have at least one active server.

TABLE 4-29 describes the parameters for setting servers for a load balancing group to active or standby.

TABLE 4-29 Parameters for Setting Servers to Active or Standby

Parameter	Description
<i>service_name</i>	Name of the load balancing service to which this load balancing group belongs.
<i>lb_group_name</i>	Name of the load balancing group.
<i>server</i>	Qualifier for the server or service.
<i>ip_addr</i>	Server IP address.
<i>host_name</i>	Server host name.
<i>port</i>	Port number on the server where this service is being offered.
<i>protocol</i>	Corresponding protocol on the back end server.

TABLE 4-29 Parameters for Setting Servers to Active or Standby

Parameter	Description
mode	Qualifier for the server mode.
<i>active</i>	Server or service set as active for this LB group.
<i>standby</i>	Server or service set as standby for this LB group.

Note – Port NAT is not supported at this time. So the *port* and *protocol* field values are ignored.

Example

The following example, modifies service SVC1 on the server with the IP address of 192.50.50.210 at port 80 and places it in standby mode.

```
puma(config){admin}# modify service lb-group server SVC1:default
server 192.50.50.210:80 mode standby
```

▼ To Remove Load Balancing Groups

- As admin in config mode, remove one or more load balancing service groups:

```
puma(config){admin}# remove service lb-group name service_name:lb_group_name
[service_name:lb_group_name]
```

The `remove service lb-group` command removes one or more load balancing groups from a service.

The default load balancing group cannot be removed by this command.

This command should always be followed by a `build rules` command before the removal of the rules contained in this load balancing group is effective.

Examples

The following example removes the load balancing group GRP1 from the service SVC1.

```
puma(config){admin}# remove service lb-group name SVC1:GRP1
```

Load Balancing Configuration Listings

The Sun Fire B10n content load balancing blade enables you to list load balancing configurations by service, rule, group, or servers.

▼ To List Load Balancing Services

The `show service` command lists the configurations of a particular service if specified. Otherwise this command lists the configurations of all the load balancing services that have been created. By default, all services are listed.

- **As any user, enter the `show service` command.**

```
B10n {user}# show service service_name
```

Where *service_name* is the name of the service to be retrieved.

Returns

Table of services listed by name with the values of the following basic parameters listed against each service, or the configurations of a single service if specified:

- Primary service point IP address and port
- Service protocol (TCP/UDP)
- Layer at which the service is load balanced (Layer 4 or Layer 7)
- Status of the service (enabled/disabled)
- List of default servers and default load balancing scheme
- List of service association names linked to the service
- VLAN tag for data traffic if configured
- Persistence (IP persistence and service point tracking) configurations, if any
- SSL configurations if any

- list of service points (VIP and port) with the SSL support (whether SSL enabled or not) and the binding interface listed for each service point
- DoS avoidance status (enabled/disabled)

▼ To List Load Balancing Rules

The `show rule` command lists a particular load balancing rule if specified. Otherwise the command lists all the load balancing rules that have been created so far. By default, all rules are listed.

- **As any user, enter the following command:**

```
puma{user}# show rule [rule_name]
```

Where `rule_name` is the name of the rule to be retrieved.

The command provides output showing a list of load balancing rule names with their respective type and content specified (or the type and content of a single rule if specified).

Returns

A list of load balancing rule names with their respective type and content specified (or the type and content of a single rule if specified).

Examples

To show all load balancing rule names and their respective type and content, use the following example:

```
puma{user}# show rule
```

To see specific rule type and content, specify the rule name:

```
puma{user}# show rule HttpCookieR1
```

▼ To List Load Balancing Groups

- As any user, enter the following command:

```
puma{user}# show service-lb-group service_name [lb_group_name]
```

Where:

`service_name` is the name of the load balancing service to which this load balancing group belongs.

`lb_group` is the name of the load balancing group entry to be retrieved.

The `show service-lb-group` command lists the information about a particular load balancing group if specified. Otherwise this command lists the information about all the load balancing groups for a given service.

Returns

Table containing all the relevant load balancing groups. Each group has a row containing the following information:

- Load balancing group name
- Name of the service to which it belongs
- Names and actual rule strings of all the rules linked with it
- Load balancing scheme used
- All the servers and services associated with it (with the weight specified against each server if the load balancing scheme is weighted round robin)

If a load balancing group is specified, then all this information is listed for that particular group.

Examples

```
puma{user}# show service-lb-group SVC1
```

```
puma{user}# show service-lb-group SVC1 default
```

▼ To List All Servers in the System

The `show server` command lists all the servers in the system that are included in one or more load balancing service associations for all the services configured on the content load balancing blade.

- **As any user, enter the following command:**

```
B10n {user}# show server
```

The following information is listed for each server entry:

- server IP address
- enabled/disabled
- up/down

Configuring the System

The Sun Fire B10n content load balancing blade can be loaded with three different images and booted. The three images are `image 1`, `image 2`, and `diag`.

The image can be upgraded interactively or non interactively.

▼ To Configure the Image for the Next Reboot

1. **As admin in config mode, set the boot image:**

```
puma(config){admin}# boot image {1|2|diag}
```

Options for the `boot image` are 1, 2, or `diag`.

Example

This example sets the diagnostics image to be used for the next reboot.

1. **Set the diagnostics image to be used for the next reboot:**

```
puma(config){admin}# boot image diag
```

2. To make this the permanent setting, use the commit command:

```
puma(config){admin}# commit
```

3. Reboot the system:

```
puma(config){admin}# reboot
```

▼ To Download a New Boot Image Over the Network

1. As admin, download the new boot image:

```
puma{admin}# update image {hostname|ip_addr} file file_name image  
{1|2|diag}
```

This command downloads a new boot image over the network and writes it into flash PROM. The new image takes effect after a system reboot. This command is available in interactive and noninteractive modes.

Example

The following example updates image 2 using the file pkgname from the remote server at IP address 192.50.50.201:

1. As admin, update the image:

```
puma{admin}# update image 192.50.50.201 file pkgname image 2
```

2. Reboot the system:

```
puma{admin}# reboot
```

▼ To Configure the Diagnostics Level

The `diag level` command configures the diagnostics level and also the level of verbosity of the diagnostics.

- As admin in config mode, enter the following command:

```
puma(config){admin}# diag level {0|1|2} verbose {0|1|2}
```

TABLE 4-30 describes the parameters for configuring the diagnostic and verbosity level.

TABLE 4-30 Parameters for Configuring the Diagnostic and Verbosity Level

Parameter	Description
<i>0</i>	Minimum level of diagnostics and verbosity.
<i>1</i>	Intermediate level of diagnostics and verbosity.
<i>2</i>	Maximum level of diagnostics and verbosity.

By default, the diagnostics level is 0 and the verbosity level is 0.

These values are used whenever the system boots with the diag image.

Examples

The following example configures the diagnostic level as 1 and the verbosity as 2:

```
puma(config){admin}# diag level 1 verbose 2
```

▼ To Configure the Debug Level for Specific Modules

The `debug module` command configures the debug level for a specified module in the system.

- **As admin in config mode, enter the following command:**

```
puma(config){admin}# debug module module_name level {0-5}
```

TABLE 4-31 describes the parameters for configuring the debug level for specified modules:

TABLE 4-31 Parameters for Configuring the Debug Level for Specific Modules

Parameter	Description
<i>module_name</i>	Name of the module.
0-5	Allowed range of values for the debug level. A debug level of 0 means debug is turned off while a level of 5 means all debug messages are activated. The default level is 0.

TABLE 4-32 describes the module names to use for configuring the debug level:

TABLE 4-32 Module Names to Use for Configuring the Debug Level

Module Name	Description
lb	Load balancing module.
network	Networking module.
failover	Failover module.
mgmt	Management module.
sys	System-level modules.
npu-if	Module interfacing with the NPU.
class-if	Module interfacing with the Classifier.

Example

The following example configures the load balancing module at level 2.

```
puma(config){admin}# debug module lb level 2
```

▼ To Shutdown the System

The `shutdown` command does a graceful shutdown of the system. This command is available in both interactive and non-interactive mode. By default, this command is in the interactive mode and asks for confirmation before shutting down the system.

- **As admin in config mode, enter the following command:**

```
puma(config){admin}# shutdown [force]
```

Where `force` forces the shutdown without asking for confirmation.

Examples

The first example shuts down the system using the interactive mode.:

```
puma(config){admin}# shutdown
```

The following example shuts down the system using the non-interactive mode:

```
puma(config){admin}# shutdown force
```

▼ To Reboot the System

The `reboot` command resets the system. It is available in both interactive and non-interactive mode. By default, this command is in the interactive mode and asks the user for confirmation before rebooting the system.

- **As admin, enter the following command:**

```
puma(config){admin}# reboot [force]
```

Where `force` forces the reboot without asking for confirmation.

Examples

The first example reboots the system using the interactive mode.:

```
puma(config){admin}# reboot
```

The following example reboots the system using the non-interactive mode:

```
puma(config){admin}# reboots force
```

▼ To Show the Date and Time

Shows the current system date and time.

- **As any user, type the following command:**

```
puma{user}# show date
```

▼ To Show the System Settings on the B10n

The `show system` command shows the current system settings. It gives information about the current image, its version, the current configuration file in flash being used, and so on.

- **As any user, type the following command:**

```
puma{user}# show system
```

▼ To Show the System Uptime

The `show uptime` command shows the uptime for the system.

- **As any user, type the following command:**

```
puma{user}# show uptime
```

▼ To Show Memory

The `dump memory` command dumps the system memory to the screen. By default 32 bytes are dumped starting from the specified memory location.

- **As any user, type the following command:**

```
puma{user}# dump memory addr [size]
```

TABLE 4-33 describes the parameters for the `dump memory` command:

TABLE 4-33 Parameters for the `dump memory` Command

Parameter	Description
<code>addr</code>	Address on the system memory to dump from (in hex without the leading '0x').
<code>size</code>	Number of bytes to dump.

Examples

The first example dumps memory from address 56789abc using the default size.

```
puma{user1}# dump memory 56789abc
```

The following example dumps memory from address 56789abc, but specifies the size of 8 bytes:.

```
puma{user1}# dump memory 56789abc 8
```

▼ To Show Modules

The `dump module` command dumps the information regarding a specific module to the screen.

- As any user, type the following command:

```
puma{user}# dump module module_name [index]
```

TABLE 4-34 describes the parameters for the dump module command:

TABLE 4-34 Parameters for the dump module Command

Parameter	Description
<i>module_name</i>	Name of the module.
<i>index</i>	(Optional) Index of the sub-module.

TABLE 4-35 describes the valid module names to use with dump module command:

TABLE 4-35 Module Names to Use with the dump module Command

Module Name	Description
npu	The NPU
classifier	The Classifier Registers.
sysctl	The System Controller Registers.
vxworks	The CPU.

The following table lists the modules in the NPU by index:

TABLE 4-36 Modules in the NPU Listed by Index

Index	Sub-Module Name
0	BAD
1	MID
2	HIF
3	OM
4	PIM A
5	PIM B
6	PIM C
7	PIM D

TABLE 4-36 Modules in the NPU Listed by Index *(Continued)*

Index	Sub-Module Name
8	POM A
9	POM B
10	POM C
11	POM D
12	PPE A
13	PPE B
14	PPE C
15	PPE D
16	SB A
17	SB B
18	SB C
19	SB D
20	CS
21	LAB
22	GMAC A
23	GMAC B
24	SPI3 IF
25	HAL
26	Server Table Allocator
27	LB Group Allocator

Examples

The following example dumps module NPU 3 to the screen:

```
puma{user1}# dump module npu 3
```

▼ To Export a Configuration to a Remote Host

The `export config` command exports a configuration file to another machine. After you specify the user name for logging into the remote host, the content load balancing blade responds to this command with a prompt for the password.

This interactive command prompts you for the hostname/IP address of the remote host to export the configuration to, the configuration file to export, the path on the remote host to export the file to, the username, and the password.

- As admin in config mode, enter the following command:

```
puma(config){admin}# export config
```

▼ To Import a Configuration From a Remote Host

The `import config` command imports a configuration file from another machine. After you specify the user name for logging into the remote host, the content load balancing blade responds to this command with a prompt for the password.

This interactive command prompts you for the hostname/IP address of the remote host to import the configuration from, the configuration file to import, the path on the remote host to import the file from, the username, and the password.

- As admin in config mode, enter the following command:

```
{admin}# import config
```

▼ To Commit the Current Configuration

- As admin in config mode, enter the following command:

```
puma(config){admin}# commit [force]
```

This command saves all the configuration writes into nonvolatile memory so that the writes can be recovered upon a restart. This is an interactive command and it prompts you for confirmation. To bypass the interactive mode, use the `force` option.

▼ To Show the Current Saved Configuration

- As any user, enter the following command:

```
puma{user}# dump config
```

This command displays all the configurations saved in the flash memory.

▼ To Remove the Current Configuration in Flash

The `erase config-files` command erases the current configuration in flash. By default, the command is interactive and asks for confirmation before removing the configuration in flash memory.

A maximum of two configuration files can be in flash memory. The configuration file that will be removed by the `erase config-files` command is the current configuration file, which you can obtain with the `show system` command.

- As admin in config mode, enter the following command:

```
puma(config){admin}# erase config-files [force]
```

Where `force` forces the removal of the current configuration file.

Example

The following example forces the removal of the current configuration file:

```
puma(config){admin}# erase config-files force
```

▼ To Specify the Configuration in Flash to Use after a System Reboot

There can be two configuration files in flash. The `boot config` command specifies which configuration file to use the next time the load balancing blade comes up after a system reboot.

- **As admin in config mode, enter the following command:**

```
puma(config){admin}# boot config {1|2}
```

Where 1 is configuration 1 and 2 is configuration 2.

Examples

The following example specifies that configuration file 2 be used when the system reboots:

```
puma(config){admin}# boot config 2
```

Flash File System Commands

▼ To Output a File to the Screen

- **As admin, enter the following command:**

```
puma{admin}# cat file_name
```

The `cat` command outputs a file in the flash file system to the screen.

▼ To Change the Current Directory

- **As any user, enter the following command:**

```
puma{user}# cd new_directory
```

▼ To Copy a File

- As any user, enter the following command:

```
puma{user}# cp src_file dst_file
```

▼ To Rename a File

- As admin in non-config mode, enter the following command:

```
puma{admin}# mv old_file new_file
```

▼ To Delete a File

- As admin in non-config mode, enter the following command:

```
puma{admin}# rm filename
```

▼ To Create a New Directory

- As admin in non-config mode, enter the following command:

```
puma{admin}# mkdir dir_name
```

▼ To Remove a Directory

- As admin, enter the following command:

```
puma{admin}# rmdir dir_name
```

▼ To List Files

- As any user, enter the following command:

```
puma{user}# ls
```

▼ To Print the Current Working Directory

- As any user, enter the following command:

```
puma{user}# pwd
```

▼ To Compress All Files in a Directory

- As any user, enter the following command:

```
puma{user}# tar tar_file_name dir_name
```

Where *tar_file_name* is the name of the tar file created and *dir_name* is the name of the file or directory to be compressed.

▼ To Uncompress Files

- As any user, enter the following command:

```
puma{user}# untar tar_file_name
```

Where, *tar_file_name* is the name of the compressed file.

▼ To Display Contents of a Compressed File

- As any user, enter the following command:

```
puma{user}# tarinfo tar_file_name
```

Where, *tar_file_name* is the name of the compressed file whose contents you want to display.

Other Useful Commands

▼ To Clear the Screen

- As any user, enter the following command

```
puma{user}# clear
```

▼ To Create an Alias for Any Command

- As any user, enter the following command:

```
puma{user}# alias addgrp set service lb-group
```

▼ To Send a Message to All Logged-on Users

- As any user, enter the following command:

```
puma{user}# broadcast "msg"
```

Where *msg* is the message string to be broadcast. The string must be surrounded by double quotes.

Use this command to send a message to all the users logged into the Sun Fire B10n content load balancing blade.

▼ To Echo a String on the Screen

- As any user, enter the following command

```
puma{user}# echo string
```

▼ To View the Command-Line Interface Tree

- As any user, enter the following command:

```
puma{user}# tree
```

Returns the command-line interface tree.

CODE EXAMPLE 4-1

```
sc0> console s1
[connected with input enabled]
puma# tree
+---alias
|
+---broadcast
|
+---cat
|
+---cd
|
+---clear
```

CODE EXAMPLE 4-1

```
sc0> console s1
|
+---commit
|
+---config
|   |
|   +---boot
|   |   |
|   |   +---config
|   |   |
|   |   +---image
|   |
|   +---build
|   |   |
|   |   +---rules
|   |
|   +---data
|   |   |
|   |   +---vlan
|   |
|   +---debug
|   |
|   +---default
|   |   |
|   |   +---failover
|   |   |   |
|   |   |   +---primary
|   |   |   |
|   |   |   +---secondary
|   |   |
|   |   +---gateway
|   |   |
|   |   +---hostname
|   |   |
|   |   +---qos
|   |   |
|   |   +---tcp-dos-params
|   |   |
|   |   +---tcp-handoff-params
|   |   |
|   |   +---tcp-params
|   |
|   +---diag
|   |
|   +---dns
|   |   |
|   |   +---server
```

CODE EXAMPLE 4-1

```
sc0> console s1
|
|   +---suffix
|
+---enable
|
|   +---failover
|
+---lb
|
|   +---failover
|
+---server
|
+---service
|
|   +---app-monitor
|
|   +---name
|
|   +---tcp-dos
|
|   +---vlan
|
+---ssl
|
|   +---name
|
+---vlan
|
+---erase
|
|   +---config-files
|
+---failover
|
|   +---monitor
|
|   +---peer
|
+---http-rule
|
+---ip
|
+---ip-rule
|
+---ipmp
```

CODE EXAMPLE 4-1

```
sc0> console s1
|
| +---primary
| |
| | +---testip
| |
| +---management
| |
| | +---vlan
| |
| +---modify
| |
| | +---service
| | |
| | | +---lb-group
| | | |
| | | | +---server
| | | |
| | | +---ssl
| | | |
| | | | +---mode
| |
| +---remove
| |
| | +---dns
| |
| | +---rule
| |
| | +---service
| | |
| | | +---cookie-persist
| | | |
| | | | +---lb-group
| | | | |
| | | | | +---name
| | | | |
| | | | | +---rule
| | | | |
| | | | | +---server
| | |
| | | +---name
| | | |
| | | | +---point
| | | |
| | | | +---ssl
| | | |
| | | | +---tracking
```

CODE EXAMPLE 4-1

```
sc0> console s1
|
|   +---ssl
|   |
|   |   +---if
|   |   |
|   |   |   +---name
|   |   |   |
|   |   |   |   +---port-pair
|   |
|   +---server-monitor
|   |
|   +---service
|   |
|   |   +---cookie-persist
|   |   |
|   |   |   +---ip-persist
|   |   |   |
|   |   |   |   +---lb-group
|   |   |   |   |
|   |   |   |   |   +---default
|   |   |   |   |   |
|   |   |   |   |   |   +---name
|   |   |   |   |   |   |
|   |   |   |   |   |   |   +---rule
|   |   |   |   |   |   |   |
|   |   |   |   |   |   |   |   +---server
|   |
|   |   +---name
|   |   |
|   |   |   +---point
|   |   |   |
|   |   |   |   +---qos
|   |   |   |   |
|   |   |   |   |   +---ssl
|   |   |   |   |   |
|   |   |   |   |   |   +---tcp-dos-params
|   |   |   |   |   |   |
|   |   |   |   |   |   |   +---tcp-handoff-params
|   |   |   |   |   |   |   |
|   |   |   |   |   |   |   |   +---tcp-params
|   |   |   |   |   |   |   |   |
|   |   |   |   |   |   |   |   |   +---tracking
|   |   |   |   |   |   |   |   |   |
|   |   |   |   |   |   |   |   |   |   +---vlan
|   |
|   +---ssl
```

CODE EXAMPLE 4-1

```
sc0> console s1
|
|
| +---if
| |
| | +---name
| | |
| | | +---port-pair
| |
| | +---vip-netmask
|
+---cp
|
+---dump
|
| +---config
| |
| | +---file
| | |
| | | +---memory
| | |
| | | +---module
|
+---echo
|
+---exec
|
+---exit
|
+---export
| |
| | +---file
|
+---help
|
+---history
|
+---import
| |
| | +---file
|
+---login
|
+---logout
|
+---ls
|
+---mkdir
```

CODE EXAMPLE 4-1

```
sc0> console s1
|
+---mv
|
+---ping
|
+---post
|
+---pwd
|
+---reboot
|
+---rm
|
+---rmdir
|
+---show
|   |
|   +---arp
|   |
|   +---build
|   |   |
|   |   +---status
|   |
|   +---date
|   |
|   +---default
|   |   |
|   |   +---qos
|   |   |
|   |   +---tcp
|   |
|   +---failover
|   |
|   +---last
|   |   |
|   |   +---build
|   |   |   |
|   |   |   +---status
|   |
|   +---network
|   |
|   +---rule
|   |
|   +---server
|   |
|   +---service
```

CODE EXAMPLE 4-1

```
sc0> console s1
|
| +---service-lb-group
| |
| +---ssl
| |
| +---system
| |
| +---uptime
| |
| +---user
| |
| +---vip
| |
| +---vlan
|
+---shutdown
|
+---stty
| |
| +---hardwrap
| |
| +---status
|
+---tar
|
+---tarinfo
|
+---tree
|
+---untar
|
+---update
```

▼ To Print the History of All Executed Commands

- As any user, enter the following command:

```
puma{user}# history
```

Prints out all the commands executed till now in this session.

▼ To Get Help for CLI Commands

- As any user, enter the following command:

```
puma{user}# help command
```

Using the `help` command alone gets help on all commands. Entering a specific command, such as `set service lb-group server`, returns help for that specific command.

You can also get help by entering the command name and a question mark (?), for example:

```
puma{user}# service ?
```

▼ To Logout

- As any user, enter the following command:

```
puma{user}# logout
```

Logs out from the current console session.

▼ To Exit From a Script

- As any user, enter the following command:

```
puma{user}# exit
```

▼ To Retrieve the Current User Information

- As any user, enter the following command:

```
puma{user}# whoami
```

▼ To Retrieve Information About All Users

- As any user, enter the following command:

```
puma{user}# who
```

▼ To Display Console Settings

- As any user, enter the following command:

```
puma{user}# stty status
```

Use this command to display the console settings.

▼ To Turn On Hardwrap on the Console

- As any user, enter the following command:

```
puma{user}# stty hardwrap
```

Configuring VLAN Parameters

A virtual LAN (VLAN) is a collection of network nodes that share the same broadcast domain regardless of their physical location or connection point in the network. A VLAN serves as a logical workgroup with no physical barriers. Thus users can share information and resources as though located on the same LAN. VLANs also allow a single physical LAN to be divided into multiple logical LANs. By restricting the flow of traffic between the members of different VLANs, this allows the separation of tenants or tiers.

This chapter describes the types of VLANs available and shows how to enable and configure VLAN parameters for the Sun Fire B10n content load balancing blade.

This chapter includes the following topics:

- “Available VLAN Types” on page 123
- “Enabling VLAN Tagging” on page 124
- “Disabling VLAN Tagging” on page 128

Available VLAN Types

The Sun Fire B10n content load balancing blade CLI allows for the configuration of three different VLAN types:

- Management VLAN:

As its name suggests, this VLAN is used for management traffic to and from the load balancing blade. Examples are telnet traffic to the console and signaling between the load balancer and the server. The latter includes service configuration messages and server module health monitoring. When the management VLAN is enabled, outbound management traffic is enforced for added security, and outbound management is tagged with this VLAN ID. There is one data VLAN per load balancing blade.

- Data VLAN:

This VLAN carries traffic from the client to the load balancer. The servers are expected to use this VLAN for the response traffic back to the client. When the load balancing blade sends packets to the client (such as during the handshake to establish a connection), it tags these packets with this VLAN ID. However, there is no inbound enforcement for the data VLAN. There is one data VLAN per load balancing blade.

- Service VLAN:

This VLAN is used for all data traffic between the load balancing blade, the server, and potentially the SSL proxy blade. Each service on the load balancing blade may have its own service VLAN configured.

Enabling VLAN Tagging

The `enable vlan` command enables the VLAN tagging of data or management traffic from the Sun Fire B10n content load balancing blade.

By default, VLAN tagging of all traffic from the blade is disabled.

When tagging is enabled, the VLAN ID used for tagging the management traffic is the one set by the `management vlan` command. The management vlan setting also filters incoming traffic.

The ID used for tagging client traffic is the one set by the `data vlan` command.

▼ To Set Client Traffic VLAN Tag

The `data vlan` command sets the default VLAN ID to be used on all outbound data traffic destined to and from the client.

This parameter must be set for each blade and serves as a default. This parameter is valid only if the content load balancing blade is enabled for VLAN tagging of outbound traffic by the `enable vlan` command.

The valid range for VLAN ID values is *1* to *4095*.

- **As admin in config mode, type the following command:**

```
puma(config){admin}# data vlan vlan_id
```

The default VLAN ID is 1.

▼ To Enable VLAN Tagging

- **As admin in config mode, enter the following command:**

```
puma(config){admin}# enable vlan all
```

The `enable vlan all` command enables vlan tagging for both management traffic and client traffic.

- **As admin in config mode, enter the following command:**

```
puma(config){admin}# enable vlan management
```

The `enable vlan management` command enables vlan tagging for management traffic only.

- **As admin in config mode, enter the following command:**

```
puma(config){admin}# enable vlan data
```

The `enable vlan data` command enables vlan tagging for client traffic only.

▼ To Set Management VLAN

The `management vlan` command sets the management VLAN ID on the content load balancing blade. When the management VLAN is enabled, the blade processes inbound management traffic only when it is tagged with this VLAN ID. The blade also uses the VLAN ID to tag all outbound management traffic.

The valid range for VLAN ID values is 1 to 4095.

- As admin in config mode, type the following command:

```
puma(config){admin}# management vlan vlan_id
```

Where *vlan_id* is the management VLAN tag.

▼ To Set VLAN for Service

The `service vlan` command sets the VLAN tag to be added to all the traffic of a service.

- As admin in config mode, enter the `service vlan` command:

```
puma(config){admin}# service vlan service_name vlan vlan_id
```

Where:

service_name is the name of the service.

`vlan` is the qualifier for the VLAN ID.

vlan_id is the VLAN ID.

The valid range for VLAN ID values is 1 to 4095.

Defaults

The default is the value configured for the content load balancing blade.

Example

The following example uses the *vlan_ID* of 20 for the service SVC1.

```
puma(config){admin}# service vlan SVC1 vlan 20
```

▼ To Enable VLAN Tagging for a Service

- As admin in config mode, enter the `enable service vlan` command:

```
puma(config){admin}# enable service vlan service_name
```

By default, VLAN tagging is disabled for a service.

Examples

```
puma(config){admin}# enable service vlan SVC1
```

▼ To Disable VLAN Tagging for a Service

- **As admin in config mode, enter the `no enable service vlan` command:**

```
puma(config){admin}# no enable service vlan service_name
```

By default, VLAN tagging is disabled for a service.

Examples

The following example disables VLAN tagging for the service SVC1.

```
puma(config){admin}# no enable service vlan SVC1
```

▼ To Show VLANs

- As admin, enter the `show vlan` command:

```
puma{admin}# show vlan
```

You will see output similar to the following:

```
VLAN
-----
Management ID: 2      (ENABLED)
Data ID: 1           (ENABLED)

SERVICE NAME                VLAN ID  ENABLED/DIS
-----
svc1                          100     ENABLED
svc83                          1       DISABLED
svc84                          1       DISABLED
puma{admin}#
puma{admin}#
```

Disabling VLAN Tagging

The `no enable vlan` command disables the VLAN tagging of outbound data or management traffic from the content load balancing blade.

- As admin in config mode, type the following command:

```
puma(config){admin}# no enable vlan parameter
```

TABLE 5-1 describes the parameters for the `no enable vlan` command:

TABLE 5-1 Parameters for the `no enable vlan` Command

Parameter	Description
<code>data</code>	Disables VLAN tagging of outbound data traffic.
<code>management</code>	Disables VLAN tagging of outbound management traffic.
<code>all</code>	Disables VLAN tagging of all outbound traffic.

By default, VLAN tagging of all outbound traffic is disabled on the content load balancing blade.

- **As admin in config mode, type the following command:**

```
puma(config){admin}# no enable vlan all
```

The `no enable vlan all` command disables VLAN tagging for both management and client traffic.

- **As admin in config mode, type the following command:**

```
puma(config){admin}# no enable vlan management
```

The `no enable vlan management` command disables VLAN tagging for management traffic only.

- **As admin in config mode, type the following command:**

```
puma(config){admin}# no enable vlan data
```

The `no enable vlan data` command disables VLAN tagging for client traffic only.

Updating the Application Software and the BSC Firmware

This chapter tells you how to upgrade the software and firmware on one or more Sun Fire B10n content load balancing blades. It also tells you how to set up a TFTP (Trivial File Transfer Protocol) server if you do not already have one set up on your network. The software upgrade procedures require you to use TFTP.

- “Introduction” on page 131
 - “Setting up a TFTP Server” on page 132
 - “Software Architecture” on page 133
 - “Updating the B10n Software” on page 135
 - “Updating the BSC Firmware” on page 136
 - “Choosing the Boot Image” on page 139
-

Introduction

Note – To perform the update procedures in this chapter, you need to log into one of the System Controllers (SCs) using telnet. This is because you need to transfer the new firmware from a location on your network.

The BSC on each blade server is a management agent for the System Controller. It communicates information about the blade server it resides in to the System Controller. It also receives and processes any commands that you type into the System Controller’s command-line interface.

Follow the instructions in this chapter if you have been advised by a Sun support engineer to download new firmware onto a System Controller, blade server, or integrated switch.

Setting up a TFTP Server

The procedures for upgrading software for the Sun Fire B10n content load balancing blade involve using TFTP. This means that to perform them you need to have a TFTP server available on your network.

Note – If you are using separated data and management networks, you need a TFTP server available on both networks.

To configure a Solaris system on your network to serve TFTP requests, do the following:

1. **On the system that you intend to set up as the TFTP server, log in as root.**
2. **Use a text editor to un-comment the following line in the file `/etc/inetd.conf`:**

```
tftp dgram udp6 wait root /usr/sbin/in.tftpd in.tftpd -s /tftpboot
```

3. **On the same system create a TFTP home directory by typing the following at the Solaris prompt:**

```
# mkdir /tftpboot
# chown root /tftpboot
# chmod 755 /tftpboot
```

4. **Restart `inetd` by typing:**

```
# /etc/inet.d/inetsvc stop
# /etc/inet.d/inetsvc start
```

5. **Verify that TFTP is working.**

To do this, use TFTP to get a file from the `/tftpboot` directory. Follow the instructions below:

- a. On the system that you are using as the TFTP server, copy any file (for example, the Solaris `/etc/release` file) to the `/tftpboot` directory.

Type the following command at the Solaris prompt:

```
# cp /etc/release /tftpboot/filename
```

Where *filename* is the name of the file you intend to make available on the TFTP server.

- b. Make the file you have just copied read-only:

```
# chmod 444 /tftpboot/filename
```

where *filename* is the name of the file you intend to make available on the TFTP server.

Note – Note that TFTP is not the same as FTP. It does not display the same error messages as FTP, and you cannot use the `cd` or `ls` commands (or indeed most other commands) that FTP allows you to use.

Software Architecture

The Sun Fire B10n content load balancing blade provides optimized server to client response. To support this response and provide tight communications between the content load balancing blade and the B1600 blade servers a software module must be installed on each of these servers. This software module is referred to as the Blade Server Module and is loaded using the Solaris `pkgadd` process.

The content load balancing blade is based on specialized hardware including a general purpose microprocessor that runs a real time operating system. The code that runs on this processor is called the Application Software and can be updated using a TFTP process.

In addition to the general purpose processor there is a micro controller called the Blade Support Controller (BSC). The BSC is the primary interface to the Sun Fire B1600 Service Controllers (SC) and performs the Advanced Lights-out Management (ALOM) function for a given blade. These functions include powering on and off of the blades as well as monitoring functions. This is referred to as the BSC Firmware and can be updated using the “flashupdate” command which involves using TFTP.

The Sun Fire B10n software components:

- Blade server module
- B10n application software
- BSC firmware

The B10n has the capability to hold two versions of the Application Software and a diagnostic image. This allows a new image to be loaded without overwriting the active image. The blade must be rebooted to activate an image. See “Choosing the Boot Image” on page 139.

The B10n specialized hardware includes a rule based classification engine. The rules are entered through the command line interface and then compiled using a build process. See “Creating an HTTP Load Balancing Rule” on page 82.

Check the following web site to ensure you have the latest Sun Fire B10n software:

<http://www.sun.com/software/download/network.html>

See “Updating the B10n Software” on page 135 for instructions on checking the version of the software you are currently using.

Updating the B10n Software

The B10n software can be loaded with three different images and booted. The three images are image 1, image 2, and diag. These images denote software versions.

Before you update the software, use the `show system` command to see which software version is currently active:

```
puma{admin}# show system
Boot Options
-----
Config Type   Config File   Boot Image   Diag Level   Verbose Mode
-----
running       1             1             0             0
next          1             1             0             0

Image Information:

Image   Blade Type   Version           Build Date       Build Time       Size
-----
-----
1       B10n         1.0.e_QA          04/25/03         17:19           3621020
2       B10n         1.0.d_QA          04/18/03         13:29           3612843
diag    B10n         1.0.diag_e_QA    04/25/03         17:18           2521770
-----
-----
```

You can upgrade the software either interactively or noninteractively.

To load to image location 1, the blade expects image `pkgname` to be available in the TFTP server.

Updating the BSC Firmware

- Using the TFTP server from the server controller enter the following command:

```
sc> flashupdate -s tftp_ip -f file Sn
```

Where *S* indicates the slot and *n* is the number of the slot containing the blade you want to update. Valid slot numbers range from 0 to 15.

The following example shows the TFTP IP address as 10.4.128.103 and the file as /tftpboot/FRU/bsc-rel/scg-nrst-03.flash, updating the blade in slot 4. It also shows the messages that are returned and prompts:

```
sc> flashupdate -s 10.4.128.103 -f /tftpboot/FRU/bsc-rel/scg-nrst-03.flash S4

Warning: Are you sure you want to flashupdate the S4 bsc image;
all console connections to S4 will be lost (y/n)? y

S4: Preparing to flashupdate.
Warning: Cannot determine supported blade type.

Do you want to continue (y/n)? y

Apr 10 19:22:46: MINOR: S4: Environmental monitoring disabled.
flashupdate: update 131072 bytes of 131072 completed on S4
S4: flashupdate complete.
Apr 10 19:23:55: MINOR: S4: OS Running.
Apr 10 19:23:56: MINOR: S4: Active LED state changed to ON.
Apr 10 19:23:56: MINOR: S4: Environmental monitoring enabled.
```

▼ To Update the Software Interactively

- As admin, enter the following command and respond to the prompts:

```
puma{admin}# update image
Are you sure to update the boot image? [y|n] y
The server address for TFTP download: 192.50.50.201
The file name for TFTP download: sunfire_b10n.1_0_b
Select which image to update {1 | 2 | diag}: 1
```

The system returns the following output:

```
file exist! will overwrite /RFA0/BOOTIMAGE/boot_image_1
Start downloading sunfire_b10n.1_0_b... using TFTP
Transferring and writing to file /RFA0/BOOTIMAGE/boot_image_1...
please wait.

puma{admin}#
```

▼ To Update the Software Noninteractively

- As admin, type the following command:

```
puma{admin}# update image tftp server file image_name image location
```

The following image uses the tftp server with the IP address of 192.50.50.201, the image name of sunfire_b10n._1_0_b, and the image at location 1.

```
puma{admin}# update image 192.50.50.201 file sunfire_b10n.1_0_b  
image 1
```

The system returns the following output, verifying the parameters entered:

```
file exist! will overwrite /RFA0/BOOTIMAGE/boot_image_1  
Start downloading sunfire_b10n.1_0_b... using TFTP  
Transferring and writing to file /RFA0/BOOTIMAGE/boot_image_1...  
please wait.  
  
puma{admin}#
```

The following image uses the tftp server with the IP address of 192.50.50.201, the image name of sunfire_b10n._1_0_b, and the image at location diag.

```
puma{admin}# update image 192.50.50.201 file sunfire_b10n.1_0_b  
image diag
```

The system returns the following output, verifying the parameters entered:

```
file exist! will overwrite /RFA0/BOOTIMAGE/boot_image_diag  
Start downloading sunfire_b10n.1_0_diag_b... using TFTP  
Transferring and writing to file /RFA0/BOOTIMAGE/boot_image_diag  
.....  
please wait.  
  
puma{admin}#
```

Choosing the Boot Image

The boot image can be specified for the next boot and made permanent or it can be specified at boot time.

▼ To Specify and Make the Boot Image Permanent

1. As admin, configure the boot image of your choice:

```
puma{admin}# config boot image 1
```

In this example, the chosen image is 1.

2. Commit the change:

```
puma{admin}# commit
commit: Are you sure to continue? [yes|no] yes
Success!
puma{admin}#
```

▼ To Specify the Boot Image at Boot Time

During boot the system prints the following message and waits for 3 seconds:

```
Press any key to choose boot image...
```

Pressing any key prompts for the image to choose for booting.

```
Specify Image To Boot <1 | 2 | d>
```

- 1 - Boots image 1.
- 2 - Boots image 2.
- d - Boots image 3.

Diagnostics and Troubleshooting

This appendix provides an overview of the diagnostic tools and instructions for invoking tests on the Sun Fire B10n content load balancing blade. There is also a section outlining some common troubleshooting issues. This appendix contains the following sections:

- “Diagnostic Tools” on page 141
- “NPU POST and SDRAM Diagnostic Tests” on page 142
- “Image Management and Troubleshooting” on page 147
- “Setting the Diagnostic Level” on page 150

Diagnostic Tools

Diagnostics for the Sun Fire B10n content load balancing blade includes NPU Power On Self Test (POST) routines, manually invoked tests, error logging routines, and debugging commands.

These diagnostics can be loosely broken down into two levels:

- Low-Level diagnostics are automatic boot time tests based on a CPU-centric view of the world. These tests are automatically done at every system bringup (boot or reset) and cannot be invoked from the CLI.
- Mid-Level diagnostics are also automatic tests and can be manually invoked through a software interface. They do a basic sanity check of all the devices on the blade.

Additional functions allow you to manually run ROM, RAM, and I/O, interface tests as well RAM and ROM read loops.

NPU POST and SDRAM Diagnostic Tests

When you boot the Sun Fire B10n content load balancing blade, you can choose from a menu to run the NPU POST, SDRAM, or LoopBack test.

- NPU POST runs automatically without user intervention.
- SDRAM allows you to run a few common tests on the memory.
- LoopBack allows you to run various LoopBack tests.

Following is an example of the diagnostics menu:

CODE EXAMPLE A-1 Diagnostics Menu

```
Copyright © 2003 Sun Microsystems, Inc.
Copyright 1984-2001 Wind River Systems, Inc.
Booting SunFire B10n Blade
Bootrom Build Date: May 12 2003, 22:36:42

Press any key to choose configuration file option...
0
Press any key to choose boot image...
2
Specify Image To Boot '1 | 2 | d'> d

Booting diag image

Booting Image /RFA0/BOOTIMAGE/boot_image_diag ...2157728

Initializing RDRAM           ... Done
Initializing SDRAM ECC       ... Done
Initializing BSC Interface   ... Done
Initializing Classifier Driver ... Done

Initialization done

****Entering Diag Code ****

                                PUMA Diagnostic Menu option:
                                =====
                                Puma Memory Test(SDRAM)           r
                                Puma Loopback Test                  l
                                Puma NPU Test                       n
                                Puma Image Update                   f
                                Quit                                 q
                                Specify the Test type :r
```

You can choose the specific tests from this menu. If you choose `r`, then the memory test is invoked and the next menu is displayed, for example:

CODE EXAMPLE A-2 Memory Test Options

```
PUMA Diagnostic Menu option:
=====

Puma Memory Test(SDRAM)      r
Puma Loopback Test           l
Puma NPU Test                 n
Puma Image Update            f
Quit                          q
Specify the Test type :r

Memory Test

List of SDRAM Memory Test to run
=====

Marching Test                m
MarchB Test                   b
Quit                          q
Specify the Test type :m

March8 Test

Valid Test Types BASIC | FULL | SPECIFY :BASIC
***RUNNING MARCHING32 TEST from Address 0x30000000 to Address 0x30100000
Marching Test: March32 test on memory starting at 0x30000000 and ending at
0x30100000.
Successfully completed Marching test

Hit [RETURN] to Enter the Memory Menu
```

- **Basic:** This test runs the chosen memory test from the memory address location 0(zero) to 1MB that is, start address is 0 in memory and end address is 100000(hex) in memory and returns “Success” on completion or Failure and where it failed.
- **Full:** This test runs a full memory test on the entire memory(256MB). This is the memory that allows the test to be run.
- **Specify:** This allows you to run memory tests on any allowed memory region. The input values are accepted in decimal value and then translated to the corresponding HEX value.

Following is an example of the SDRAM memory test menu:

```
List of SDRAM Memory Test to run
=====

Marching Test           m
MarchB Test             b
Quit                    q
Specify the Test type :
```

Similarly other tests and Test Types can be performed. Typing `q` takes you to the previous menu where other tests can be performed, for example:

CODE EXAMPLE A-3 Example of Tests

```
List of SDRAM Memory Test to run
=====

Marching Test           m
MarchB Test             b
Quit                    q
Specify the Test type :q

PUMA Diagnostic Menu option:
=====

Puma Memory Test(SDRAM)      r
Puma Loopback Test           l
Puma NPU Test                 n
Puma Image Update            f
Quit                          q
Specify the Test type :l
Initializing NPU Driver      ... Done
Loopback test

LoopBack Test Options
=====

Serdes(Internal) LoopBack    s
Back-To-Back(External) LoopBack b
NPU-To-Focus FPGA LoopBack  n
Quit                          q

Specify the Test type :
```

CODE EXAMPLE A-3 shows the choices for the various LoopBack tests between the two Gigabit Ethernet interfaces.

- The Serdes (Internal) LoopBack: This does a Internal loopback from Interface 0 to Interface 1 and back again to Interface 0. Packets of a predefined size are sent from one interface to the other and back to the originating interface and checked for correctness, errors, and so on. Then the statistics are displayed.
- Back -To -Back (External) Loopback: This requires external cabling between the two Interfaces, hence this is probably not possible on a Sun Fire B1600 chassis.
- NPU-To_Focus FPGA Loopback: This is similar to the Internal Loopback with the classifier bypassed.

```
PUMA Diagnostic Menu option:
=====

Puma Memory Test(SDRAM)      r
Puma Loopback Test           l
Puma NPU Test                 n
Puma Image Update            f
Quit                          q
Specify the Test type :n
```

Choosing `n`, Puma NPU Test, runs an automated test on the Network Processor module.

Choosing `f`, Puma Image Update, allows you to update the Image from the Diagnostics menu. Currently, this option is not available.

Quitting the Diagnostics menu automatically reboots the blade. See “The Boot Process” on page 147 for how to boot the blade and choose images for booting.

After the tests complete, the board resets itself and returns to the boot prompt and chooses the default image (Image 1) to start the Sun Fire B10n content load balancing blade application (the application image for doing the Load Balancing).

Additionally, you can invoke the NPU test, using the following syntax:

```
puma{admin}# dump module module_name index
```

For example:

```
puma{admin}# dump module npu 1
```

The `dump module` command produces output similar to the following example:

```
--- MulticastIdManager ---
Agent Base      = 40000000
Register Base   = 14030000
FBUS Errors     = 00

DBS[0] Base = 01600000
DBS[0] Size = 2

DBS[1] Base = 02600000
DBS[1] Size = 2

DBS[2] Base = 03600000
DBS[2] Size = 2

DBS[3] Base = 04600000
DBS[3] Size = 2

DBS[4] Base = 00000000
DBS[4] Size = 0

DBS[5] Base = 00000000
DBS[5] Size = 0

DBS[6] Base = 00000000
DBS[6] Size = 0

DBS[7] Base = 00000000
DBS[7] Size = 0

MID_DEALLOC_PTR      = 0000000000000000
MID_DEALLOC_DBP(0)   = 0000000000000000
MID_DEALLOC_DBP(1)   = 0000000000000000
MID_DEALLOC_DBP(2)   = 0000000000000000
MID_DEALLOC_DBP(3)   = 0000000000000000
MID_DEALLOC_DBP(4)   = 0000000000000000
MID_DEALLOC_DBP(5)   = 0000000000000000
MID_DEALLOC_DBP(6)   = 0000000000000000
MID_DEALLOC_DBP(7)   = 0000000000000000

puma{admin}#
```

Various modules will dump the Registers based on which index you choose (if present). The basic POST test is still run on all images at boot time.

Image Management and Troubleshooting

The Sun Fire B10n content load balancing blade has 32 MB (16MB X 2 Devices) of flash memory. All the system images and configuration information are stored in the flash memory.

The different system images are:

- Boot Image—Bootloader image, one for each blade
- Application image—The image that has all the software to do load balancing, two images for each board and one `diag` image.

When the blade is shipped, both the images are the same. Later you can upgrade to image 1 or image 2 from the CLI and do a commit to say you want to use the latest image. When the system is rebooted the `config` file is read to pick the right image to boot. By default Image 1 is loaded by the boot loader (Boot image) unless you commit image 2 from the CLI.

Choosing the diagnostic image (Image d) allows you to troubleshoot the blade.

The Boot Process

Once the content load balancing blade is powered on in a Sun Fire B1600 blade system chassis, it goes through the boot process. The boot loader starts an `auto_boot` by counting down two seconds before it picks up the default application image (image 1) or the image committed into the configuration file.

Actually it reads the `config` file for every boot to see which image to `auto_boot`. If for some reason the boot loader cannot boot the image, it returns to the boot prompt and prompts you to specify the other known good image (if for some reason the default is corrupted). This is one reason to have two images.

Following is a boot example:

CODE EXAMPLE A-4 Boot Example

```
Copyright © 2003 Sun Microsystems, Inc.  
  
Copyright 1984-2001 Wind River Systems, Inc.  
  
Booting SunFire B10n Blade  
Bootrom Build Date: May 5 2003, 12:22:23
```

CODE EXAMPLE A-4 Boot Example

```
Copyright © 2003 Sun Microsystems, Inc.
Press any key to choose configuration file option...
0
Press any key to choose boot image...
0
auto-booting...

Booting Image /RFA0/BOOTIMAGE/boot_image_1 ...3132576

Initializing RDRAM           ... Done
Initializing SDRAM ECC       ... Done
Initializing BSC Interface   ... Done
Initializing Classifier Driver ... Done
Initializing NPU Driver      ... Done
Initializing Lookup Pool     ... Done
Initializing Lookup Table CPU ... Done
Initializing Lookup Table NPU ... Done

Initialization done

Attaching network interface lo0... done.
Invalid device "tffs=0,00"

Using configuration directory: /RFA0/CONFIG/config_1
Classifier import failed [-712]
Application Initialization complete

Launching the Puma CLI!
Login:admin
Password:
Puma{admin}#
```

In CODE EXAMPLE A-4, note the one line of user interaction:

```
Press any key to choose boot image...
0
auto-booting...
```

You have two seconds to decide whether you want to continue with the `auto_boot` or interrupt and choose the image you want to load.

In the following example, the user chose the image to boot:

```
puma{admin}# reboot
reboot: Are you sure to continue? [yes|no] yes

Copyright 1984-2001 Wind River Systems, Inc.

Booting SunFire Content Load Balancing Blade
Build Date: Apr 3 2003, 19:39:54

Press any key to choose boot image...
1

Specify Image To Boot '1 | 2 | d'>
```

By interrupting the boot before it could `auto_boot`, you see the images you can choose from, that is, Image 1, Image 2, or the Diags Image.

In the following example, the user chose the diags image, but that image was not available. Therefore the system returned an error message. Then prompted the user to pick the right available image:

```
Press any key to choose boot image...
1

Specify Image To Boot '1 | 2 | d'> d
Error: Image <diag> boot file not found

Specify Image To Boot '1 | 2 | d'> d

Booting diag image

Booting Image /RFA0/BOOTIMAGE/boot_image_diag ...2157728

Initializing RDRAM           ... Done
Initializing SDRAM ECC       ... Done
Initializing BSC Interface    ... Done
Initializing Classifier Driver ... Done

Initialization done
```

Setting the Diagnostic Level

The default setting for the diagnostic level is 0. The default setting disables the test invocation. To run the test, you must set the `diag_level` to 1.

▼ To Set the Diagnostic Level

1. As admin, enter config mode:

```
puma{admin} # config
```

2. Set the diagnostic level to enable testing:

```
puma{config} {admin} # diag level 1
```

Note – `diag_level` is either 0 or 1 and 0 is default. You must reboot for the new setting to take effect.

Tutorial and Examples

This appendix provides a tutorial for configuring the Sun Fire B10n content load balancing blade. It includes the following sections:

- “Configuring Layer 4 and Layer 7 Load Balancing” on page 151
- “Setting Up VLAN” on page 167

Configuring Layer 4 and Layer 7 Load Balancing

Setting the Networking Configurations

Use the following procedures to set up the networking configurations.

▼ To Configure the IP Addresses

1. As admin in config mode, configure the IP address on interface 0:

```
puma(config){admin}# ip interface 0 192.50.50.134 mask  
255.255.255.0
```

2. As admin in config mode, configure the IP address on interface 1:

```
puma(config){admin}# ip interface 1 192.50.50.135 mask  
255.255.255.0
```

▼ **To Configure the Default Gateway**

- **As admin in config mode, configure the default gateway:**

```
puma(config){admin}# default gateway 192.50.50.200
```

▼ **To Configure the DNS Server**

- **As admin in config mode, configure the primary DNS server:**

```
puma(config){admin}# dns server 192.50.50.100 primary
```

▼ **To Configure DNS Suffix**

- **As admin in config mode, configure the DNS suffix:**

```
puma(config){admin}# dns suffix mycompany.com
```

Configuring a Basic Layer 4 Service Without Any Rules

▼ **To Create a Layer 4 Service**

- 1. As admin in config mode, configure a Layer 4 service:**

```
puma(config){admin}# service name svcL4 vip 199.99.9.1:80:tcp  
interface 0
```

2. Verify that the service is configured:

```
puma(config){admin}# show service svcL4
```

▼ To Add Two blade servers to the Default Load Balancing Group for the Service

1. As admin in config mode, configure the default server:

```
puma(config){admin}# service lb-group default svcL4 server  
192.50.50.10:80:tcp:5:1 192.50.50.11:80:tcp:2:0
```

2. Set the standby server to active:

```
puma(config){admin}# modify service lb-group server svcL4:default  
server 192.50.50.11:80:tcp mode active
```

3. Verify that the servers are configured in the service:

```
puma(config){admin}# show service-lb-group svcL4 default
```

4. Enable this service:

```
puma(config){admin}# enable service name svcL4
```

5. Configure the VIP 199.99.9.1 on the loopback interface of the blade servers 192.50.50.10 and 192.50.50.11.

Note – Now you can run traffic from clients to the Layer 4 service 199.99.9.1 and it is going to be load balanced between the 2 blade servers 192.50.50.10 and 192.50.50.11 in a round-robin (default load balancing scheme) fashion.

▼ To Add Another Server to the Default Load Balancing Group

1. As admin in config mode, add another server to the default load balancing group:

```
puma(config){admin}# service lb-group server svcL4:default server
192.50.50.12:80:tcp:1:1
```

2. Verify that the server was added:

```
puma(config){admin}# show service-lb-group svcL4 default
```

3. Configure the VIP 199.99.9.1 on the loopback interface of the blade servers 192.50.50.12.

Note – Now you can run traffic from clients to the Layer 4 service 199.99.9.1 and it is going to be load balanced between the 3 blade servers 192.50.50.10, 192.50.50.11 and 192.50.50.12 in a round-robin (default load balancing scheme) fashion.

▼ To Remove a Server From the Default Load Balancing Group

1. As admin in config mode, remove a server from the default group:

```
puma(config){admin}# remove service lb-group server svcL4:default
server 192.50.50.10:80:tcp
```

2. Verify that the server has been removed:

```
puma(config){admin}# show service-lb-group svcL4
```

Configuring a Basic Layer 4 Service With Rules

▼ To Configure a Layer 4 Service with Layer 4 (IP) Rule

1. As admin in config mode, add a Layer 4 rule to the system:

```
puma(config){admin}# ip-rule IP1 rule 192.50.50.200:3442 mask  
255.255.255.240:0
```

2. Verify that the rule was added:

```
puma(config){admin}# show rule
```

3. Create a Layer 4 service:

```
puma(config){admin}# service name svcL4-r vip 199.99.9.2:80:tcp  
interface 0
```

4. Verify that the service was created:

```
puma(config){admin}# show service svcL4-r
```

5. Add two blade servers to the default load balancing group for the service:

```
puma(config){admin}# service lb-group default svcL4-r server  
192.50.50.10:80:tcp:1:1 192.50.50.11:80:tcp:1:1
```

6. Configure the VIP 199.99.9.2 on the loopback interface of the blade servers 192.50.50.10 and 192.50.50.11.

7. Associate the Layer 4 service with a rule and a group of servers:

```
puma(config){admin}# service lb-group name IP-GRP service svcL4-r  
server 192.50.50.13:80:tcp:5:1 192.50.50.14:80:tcp:5:1 rule IP  
scheme wt-round-robin
```

8. Configure VIP 199.99.9.2 on loopback interfaces of server 192.50.50.13 and 192.50.50.14.

9. Verify that the service is configured:

```
puma(config){admin}# show service svcL4-r
```

10. Enable the service:

```
puma(config){admin}# enable service name svcL4-r
```

11. Build the rules:

```
puma(config){admin}# build rules
```

Note – Don't run traffic to this service yet, wait for the build to return with completion status.

12. Check the build status:

```
puma(config){admin}# show build status
```

When the build is completed, the completion message is printed out. Once you receive the completion message, you are ready to run traffic.

You can now run traffic from clients to the Layer 4 service 199.99.9.2 and the load is balanced between the blade servers in the following fashion depending on the source IP address and Layer 4 port.

- A request from client IP 192.50.50.195 and any port is going to be load balanced between the servers 192.50.50.13 and 192.50.50.14 in a weighted round robin manner as it matches the L4 rule IP1 in the IP-GRP load balancing group for this service.
- A request from client IP 192.50.50.180 and any port is going to be load balanced between the default servers 192.50.50.10 and 192.50.50.11 in a round robin fashion as it does not match the rule IP1 in the IP-GRP load balancing group for this service.

Configuring a Basic Layer 7 Service

▼ To Configure a Basic Layer 7 Service Without Rules

1. As admin in config mode, create a Layer 7 service:

```
puma(config){admin}# service name svcL7 vip 199.99.9.3:80:tcp
interface 0 lb-layer 7 L7-proto http
```

2. Add 2 servers to the default group

```
puma(config){admin}# service lb-group default svcL7 server
192.50.50.15:80:tcp:10:1 192.50.50.16:80:tcp:10:1 scheme wt-
round-robin
```

3. Enable the service:

```
puma(config){admin}# enable service name svcL7
```

4. Configure the VIP 199.99.9.3 on the loopback interface of the blade servers 192.50.50.15 and 192.50.50.16.

Note – You can now run traffic from client(s) to the Layer 7 service 199.99.9.3. The service is load balanced between the two blade servers 192.50.50.15 and 192.50.50.16 in the default load balancing group in a weighted round-robin fashion.

▼ To Configure a Layer 7 Service with Layer 7 Rules

1. As admin in config mode, add a Layer 7 rule to the system:

```
puma(config){admin}# http-rule HTML dynamic string *.html
```

2. Verify that the rule was added:

```
puma(config){admin}# show rule
```

3. Create a Layer 7 service:

```
puma(config){admin}# service name svcL7-r vip 199.99.9.4:80:tcp
interface 0 lb-layer 7 L7-proto http
```

4. Add two servers to the default group:

```
puma(config){admin}# service lb-group default svcL7 server
192.50.50.10:80:tcp:1:1 192.50.50.13:80:tcp:1:1
```

5. Associate the Layer 7 service with a rule and a group of servers:

```
puma(config){admin}# service lb-group name URL-GRP service svcL7-
r server 192.50.50.11:80:tcp:5:1 192.50.50.12:80:tcp:5:1 rule HTML
scheme wt-round-robin
```

6. Verify that the service was configured:

```
puma(config){admin}# show service svcL7-r
```

7. Enable the service:

```
puma(config){admin}# enable service name svcL7-r
```

8. Configure the VIP 199.99.9.4 on the loopback interface of the blade servers 192.50.50.10, 192.50.50.13, 192.50.50.11 and 192.50.50.12.

9. Build the rules:

```
puma(config){admin}# build rules
```

Note – Don't run traffic to this service yet, wait for the build to return with completion status.

10. Check the build status:

```
puma(config){admin}# show build status
```

When the build is completed, the completion message is printed out. Now we are ready to run traffic.

You can now run traffic from client(s) to the Layer 7 service 199.99.9.4. The service is load balanced between the blade servers in the following fashion depending on the URL of the HTTP request:

- The URL `http://199.99.9.4/index.html` is load balanced between the servers 192.50.50.11 and 192.50.50.12 in a weighted round robin manner as it matches the Layer 7 rule HTML in the URL-GRP load balancing group for this service.
- The URL `http://199.99.9.4/index.gif` is load balanced between the servers 192.50.50.10 and 192.50.50.13 in the default group in a round-robin manner as it does not match the Layer 7 rule HTML in the URL-GRP load balancing group for this service.

11. Add a CGI rule to the system:

```
puma(config){admin}# http-rule CGI cgi string server=*1
```

12. Associate the Layer 7 service with the CGI rule and a group of servers:

```
puma(config){admin}# service lb-group name CGI-GRP service svcL7-r  
r server 192.50.50.14:80:tcp:5:1 192.50.50.15:80:tcp:5:1 rule CGI  
scheme wt-round-robin
```

13. Configure the VIP 199.99.9.4 on the loopback interface of the blade servers 192.50.50.14 & 192.50.50.15.

14. Add a Cookie rule to the system:

```
puma(config){admin}# http-rule COOKIE cookie string server=server1
```

15. Associate the Layer 7 service with the Cookie rule and a group of servers:

```
puma(config){admin}# service lb-group name CK-GRP service svcL7-r  
server 192.50.50.16:80:tcp:5:1 192.50.50.17:80:tcp:5:1 rule  
COOKIE scheme wt-round-robin
```

16. Configure the VIP 199.99.9.4 on the loopback interface of the blade servers

Rules do not take effect until you issue a build rules command.

17. Build the rules:

```
puma(config){admin}# build rules
```

After the build returns with the completion message, you can run traffic to this service in the following manner:

- The URL `http://199.99.9.4/index.html` is load balanced between the servers 192.50.50.11 and 192.50.50.12 as it matches the HTML rule in the URL-GRP load balancing group for this service.
- The URL `http://199.99.9.4/index.gif` is load balanced between the servers 192.50.50.10 and 192.50.50.13 in the default group as it does not match any rule for this service.
- The request `http://199.99.9.4/index.txt?xxx=yyy&server=S1&aaa=b` is load balanced between the servers 192.50.50.14 and 192.50.50.15 as it matches the CGI rule in the CGI-GRP load balancing group for this service.
- The request with the following HTTP header is load balanced between the servers 192.50.50.16 and 192.50.50.17 as it matches the COOKIE rule in the CK-GRP load balancing group for this service:

```
GET /test.txt HTTP/1.0\r\nHost: 199.99.9.4\r\nUser-Agent: xfd\r\nCookie: server=server1\r\n\r\n
```

▼ To Configure a Service for IP Persistence

1. As admin in config mode, add IP persistence to a service:

```
puma(config){admin}# service ip-persist svcL4-r mask 8 timeout 10
```

This adds IP persistence to the service where the source IP mask is specified as 8 bits and the inactivity timeout is specified as 10 minutes.

You can now run traffic from client 192.50.50.200, and depending on the rules, it is load balanced to a particular blade server, for example, server 192.50.50.13.

Any subsequent traffic from any client in the subnet 192.50.50.0 is sent back to the same server, that is, 192.50.50.13, without any load balancing. Thus the service is now “persistent” for the subnet 192.50.50.0. If no traffic is received from the 192.50.50.0 subnet for svcL4-r for 10 minutes, then the persistence expires. Now the first connection from a client in the 192.50.50.0 subnet, say 192.50.50.185, is load balanced again and it goes to server 192.50.50.11.

▼ To Remove IP Persistence From a Service

- As admin in config mode, remove IP persistence from a service:

```
puma(config){admin}# no service ip-persist svcL4-r
```

▼ To Configure a Service for Tracking

- As admin in config mode, add port tracking to a service:

```
puma(config){admin}# service tracking svcL7-r track 0:443:tcp  
timeout 20
```

This example adds port tracking to the service where the tracking port is specified as 443 and the inactivity timeout is specified as 20 minutes.

Now when you run traffic from client 192.50.50.200, depending on the request, it is load balanced to a particular back end server, for example, server 192.50.50.13. Any subsequent traffic from the same client destined to the VIP 199.99.9.4 and port 443 is sent back to the same server, that is, 192.50.50.13, without any load balancing. Thus the traffic to port 443 now tracks the primary service. If no traffic is received from 192.50.50.200 for svcL7-r on port 443 for 20 minutes, then the tracking expires. Now

the first connection from 192.50.50.200 to the VIP 199.99.9.4 and port 80 will be load balanced to say server 192.50.50.10 and any subsequent connections from the same client, destined to either 199.99.9.4:80 or 199.99.9.4:443 go back to the same server.

▼ To Remove Port Tracking

- **As admin in config mode, remove port tracking:**

```
puma(config){admin}# remove service tracking svcL7-r track
0:443:tcp
```

▼ To Add an End Point Tracking to a Service

1. **As admin in config mode, add an end point tracking to a service:**

```
puma(config){admin}# service tracking svcL7-r track
199.99.9.5:8080:tcp timeout 30
```

This example adds end point tracking to the service where the tracking end point is specified with IP 199.99.9.5, port 8080 and protocol TCP, and the inactivity timeout is specified as 30 minutes.

2. **Configure the end point VIP 199.99.9.5 on the loopback interface of all the blade servers.**

Now when you run traffic from client 192.50.50.200, depending on the request, it is load balanced to a particular blade server, for example server 192.50.50.13. Any subsequent traffic from the same client destined to the vip 199.99.9.5 and port 8080 is sent back to the same server, that is, 192.50.50.13, without any load balancing. Thus the traffic to end point 199.99.9.5:8080:tcp now tracks the primary service. If no traffic is received from 192.50.50.200 for end point 199.99.9.5:8080:tcp for 30 minutes, then the tracking expires.

Now the first connection from 192.50.50.200 to the VIP 199.99.9.4 and port 80 will be load balanced to say server 192.50.50.10 and any subsequent connections from the same client, destined to either 199.99.9.4:80 or 199.99.9.5:8080 go back to the same server.

▼ To Remove End Point Tracking

- As admin in config mode, remove end point tracking:

```
puma(config){admin}# remove service tracking svcL7-r track
199.99.9.5:8080:tcp
```

Port tracking and end point tracking can also be added to a service configured with IP persistence in which case the tracking will be valid for any client from the subnet (as specified by the persistence mask) instead of one particular client.

▼ To Configure a Service for Cookie-Based Persistence

- As admin in config mode, enter the following command:

```
puma(config){admin}# service cookie-persist svcL7-r cookie PERSIST
offset 3 delim :
```

The cookie is set by the server on the client using the header
Set-cookie: PERSIST=xyzc03232axyz;\r\n

The client when it makes the next request sends this cookie in the header
Cookie: PERSIST=xyzc032320axyz;\r\n

If the cookie persistence is set as shown above, then the content load balancing blade parses and finds the string 'c032320a' in the cookie. The name is PERSIST and the offset is 3. The offset specifies how many bytes into the value to look for to find the start of the cookie. If the cookie matches the server the request is sent to server 192.50.50.10.

Currently, the delimiter value is ignored. If this configuration is saved and retrieved, the delimiter value is always set to ':'.

▼ To Remove Cookie Persistence from a Service

- As admin in config mode, enter the following command:

```
puma(config){admin}# remove service cookie-persist svcL7-r PERSIST
```

▼ To Configure a UDP Service

The following restrictions apply to a UDP services:

- UDP services can only be load balanced at Layer 4.
- Only the static load balancing scheme is supported.
- Persistence and tracking are not supported for UDP services.

Note – A UDP end point can be added for port/end-point tracking to a TCP service

1. As admin in config mode, create a Layer 4 service:

```
puma(config){admin}# service name svcudp vip 199.99.9.1:90:udp  
interface 0
```

2. Verify that the service was created:

```
puma(config){admin}# show service svcudp
```

3. Add two blade servers to the default load balancing group for the service:

```
puma(config){admin}# service lb-group default svcudp server  
192.50.50.18:90:udp:1:1 192.50.50.19:90:udp:1:1 scheme static
```

4. Enable this service:

```
puma(config){admin}# enable service name svcudp
```

You can now run UDP traffic from clients to the UDP service 199.99.9.1 on port 90 and it is load balanced between the two blade servers 192.50.50.18 and 192.50.50.19 in a static fashion. With the current implementation of the static load balancing

algorithm, all UDP traffic from the same client IP will go to the same server, as long as the server is available. If the server becomes unavailable, then the new traffic goes to the next available server.

Note – It is possible to add Layer 4 IP rules to a UDP service just like any other Layer 4 service.

▼ To Configure an FTP Service

FTP service configuration on the Sun Fire B10n content load balancing blade has the following restrictions:

- An FTP service can only be layer-4 load balanced.
- Assumption: The FTP server running on the blade server has the control port on 21 and data port on 20.

When configuring an FTP service ensure the following:

- The VIP end-point added has port 21 (the FTP control port) and protocol TCP.
- The load balancing layer is specified as Layer 4 and the Layer 7 protocol is specified as FTP.
- Before enabling the FTP service, add persistence to it with mask length 0 (any other mask length can be specified if such a persistence is specifically desired).

1. As admin in config mode, create an FTP service:

```
puma(config){admin}# service name svcftp vip 199.99.9.1:21:tcp
interface 0 lb-layer 4 L7-protocol ftp
```

2. Verify that the service was created:

```
puma(config){admin}# show service svcftp
```

3. Add two blade servers to the default load balancing group for the service:

```
puma(config){admin}# service lb-group default svcftp server
192.50.50.14:21:tcp:1:1 192.50.50.15:21:tcp:1:1 scheme wt-round-
robin
```

4. Configure the VIP 199.99.9.1 should be configured on the loopback interface of the blade servers 192.50.50.14 and 192.50.50.15.

5. Add IP persistence with mask length 0:

```
puma(config){admin}# service ip-persist svcftp mask 0 timeout 10
```

6. Enable this service:

```
puma(config){admin}# enable service name svcftp
```

You can now run FTP client(s) from client machine(s) to the FTP service on 199.99.9.1 and the FTP sessions will be load balanced between the 2 blade servers 192.50.50.14 and 192.50.50.15 in a weighted round robin fashion (for different client IPs as client persistence is set).

Note – It is possible to add L4 (IP) rule(s) to an FTP service just like any other Layer 4 service.

▼ To Add an End Point to a Service to make it Multi-homed

1. As admin in config mode, add an end point to a service:

```
puma(config){admin}# service point svcL4 point  
199.99.9.30:80:tcp:0:0:0
```

This command adds an end point with VIP 199.99.9.30, port 80 and protocol TCP to the service svcL4. This end point inherits all properties of the service.

2. Configure the VIP for the new end point, that is, 199.99.9.30 in this case, on the loopback interface of all the blade servers included in the service (svcL4 in this case).

Setting Up VLAN

For this example, assume the following:

- The management VLAN tag is 2 (the default for Sun Fire B1600 blade system chassis)
- The client-side VLAN tag is 1
- The service VLAN is 5
- Only the interface connected to SSC0 is used for this service.
- The management subnet is 192.50.50.0, with a mask of 255.255.255.0
- The IP address of the content load balancing blade is 192.50.50.10
- The IP address of the server on the management VLAN is 192.50.50.201
- The virtual IP address of the service is 199.99.9.1

Set Up on the Switch

The Sun Fire B10n content load balancing blade and all servers for the service must be members for all three vlans mentioned above. The ports must be set up to forward traffic on these vlans tagged.

Refer to the *Sun Fire B1600 Blade System Chassis Software Setup Guide* for the mechanism to set up the switch.

First, the VLAN database must be edited to include the VLANs to be used in the service.

Then, the port membership rules are set using the interface switch port setup.

Note – By default, VLAN 1 is forwarded on the ports untagged. In this example, the client side VLAN is forwarded tagged.

▼ To Set Up VLAN on the Server

The server must also be a member of all VLANs mentioned above. The management VLAN is used to exchange configuration messages between the content load balancing blade and the blade server. VLAN is also used for server health monitoring.

The service VLAN is used for all data plane traffic between the content load balancing blade and the blade server.

The route from the server to the client network must use the client side VLAN. For security reasons, the server cannot bind any services to its IP address on this interface.

1. Configure the client side VLAN interface:

```
# ifconfig ce1000 plumb 10.10.10.10 netmask 255.255.255.0 up
```

2. Configure the management VLAN interface:

```
# ifconfig ce2000 plumb 192.50.50.201 netmask 255.255.255.0 up
```

3. Configure the service VLAN interface:

```
# ifconfig ce5000 plumb 110.10.10.10 netmask 255.255.255.0 up
```

4. Configure the VIP on the loopback interface:

```
# ifconfig lo0:1 plumb 199.99.9.1 netmask 255.255.255.0 up
```

The IP address on the service VLAN is never used in any traffic, however, a valid IP address must be configured.

5. Add all three interfaces to the load balanced interfaces:

```
# /opt/SUNWclb/bin/clbconfig add ce1000  
# /opt/SUNWclb/bin/clbconfig add ce2000  
# /opt/SUNWclb/bin/clbconfig add ce5000
```

6. Verify that the route to the default gateway uses interface ce1000.

```
# netstat -r
```

The `netstat -r` command displays the routing table, including the default route.

7. Set the default route:

```
# route add default 10.10.10.10 0
```

Remove any other default route shown by `netstat -r`. Note that there are other ways to set the default route to use this interface. See the *Solaris Administration Guide*.

Note – If the physical interface used were connected to SSC1, the virtual interfaces would be `ce1001`, `ce2001`, and `ce5001`, respectively.

The interface number for VLAN n on physical interface i is determined by the following formula: $1000 * n + i$

Hence, the interface name for VLAN 123 on physical interface `ce0` is `ce123000`

▼ To Set Up VLAN on a Load Balancing Blade

First, set up a service as described in (relevant chapters). Assume that the name of the service is `SVC1`.

1. As admin, in config mode, set the service VLAN:

```
puma(config){admin}# management vlan 2
```

2. Enable the VLAN service:

```
puma(config){admin}# enable vlan management
```

3. Set the client side (default) VLAN:

```
puma(config){admin}# data vlan 1
```

4. Enable the client side VLAN:

```
puma(config){admin}# enable vlan data
```

5. Set the service VLAN:

```
puma(config){admin}# service vlan SVC1 vlan 5
```

6. Enable the service VLAN:

```
puma(config){admin}# enable service vlan SVC1
```

7. Enable the service:

```
puma(config){admin}# enable service name SVC1
```

Alphabetical Command Reference

This appendix provides an alphabetical listing of all the Sun Fire B10n content load balancing blade commands.

A

alias Create an alias.

B

boot Boot the system.

boot config Set the boot configuration.

boot image Configure the system image to use for the next time the content load balancing blade goes through a system reboot.

broadcast Used to send a message to all the users logged into the Sun Fire B10n content load balancing blade.

build rules Activate the rules just configured.

C

cat Output a file to the screen.

- clear** Clear the screen.
- config** Enter configuration mode.
- commit config** Activate the configuration just entered.

D

- debug module** Configure the debug level for a specified module in the system.
- default gateway** Configure a default gateway on the load balancing blade.
- default hostname** Delete service.
- default qos level** Set the default QoS level.
- default tcp-dos-params** Set the default TCP-dos parameters.
- default tcp-handoff-params** Set the default TCP-handoff parameters.
- default tcp-params** Set the default TCP parameters.
- default vlan** Configure the default VLAN.
- delete service lb-group rule** Delete service load balancing group rule.
- delete service lb-group server** Delete the service load balancing group server.
- diag level** Configure the diagnostics level and the level of verbosity of the diagnostics.
- dns primary** Set the primary dns service.
- dns secondary** Set the secondary dns service.
- dns server** Configure a DNS for the load balancing blade. When supplied with a hostname, this DNS will resolve it and obtain the corresponding IP address.
- dns suffix** Set the suffix to be added to the hostnames before resolution, for example .com.
- dump config** Display the existing configuration.
- dump memory** Dumps the system memory to the screen.
- dump module** Dump the information about a specific module to the screen.

E

echo	Echo text typed in.
enable lb failover	Enable load balancing failover.
enable server	Enable the server.
enable service	Enable the configured service.
enable service app-monitor	Enable the service application monitor.
enable service tcp-dos	Enable the TCP dos service.
enable service vlan	Enable the VLAN service.
enable vlan	Enable the VLAN setting.
exit	Exit this mode.
export config	Export a configuration.

F

failover primary-monitor	Failover to the primary monitoring system.
---------------------------------	--

H

help	Show command help.
history	Show command history.
http-rule	Set an HTTP rule.

I

- import config** Import current configuration.
- ip** Configure the real IP address for the content load balancing blade to be used for management and control, for example opening a telnet session.
- ipmp** Set the IPMP.
- ipmp testip** Set a test IP address for IPMP.
- ip-rule** Set an IP rule.

L

- list service** List a service.
- login** Log in to a user session.
- logout** Log out from a user session
- ls** List the content of the current directory

M

- management vlan** Create the management VLAN.
- modify service lb-group server** Make changes to the service for a load balancing group server.
- modify service ssl mode** Make changes to the service for the SSL mode.
- mkdir** Create a new directory.
- mv** Move a file to another directory.

N

no build rules	Remove the rules just configured.
no default gateway	Remove the default gateway
no dns server	Remove the DNS server.
no dns suffix	Unset the DNS suffix to be used by the DNS resolver.
no enable lb failover	Remove the load balancing failover.
no enable server	Remove the server.
no enable service app- monitor	Remove the service for application monitoring.
no enable service tcp- dos	Remove the TCP DoS service.
no enable service vlan	Remove the VLAN service.
no enable vlan	Remove the VLAN.
no ip	Remove the IP address.
no service cookie- persist	Remove the cookie-based persistence service.
no service ip-persist	Remove the IP persistence service.
no set gateway	Remove the gateway.

P

password	Change the current password.
ping	Check for a response from a remote IP address.
pwd	Display the current working directory on the screen.

R

reboot	Reset the system.
reboot force	Force the reboot without asking for confirmation.
remove dns server	Remove a DNS server from the system.
remove rule	Remove a rule.
remove service	Remove a service.
remove service lb-group	Remove a load balancing group.
remove service lb-group rule	Remove a load balancing group rule from a service.
remove service lb-group server	Remove a load balancing group server.
remove service point	Remove a service point.
remove service ssl	Remove an SSL service.
remove service tracking	Remove tracking a service.

S

service point	Set up a service point.
service qos	Set up a qos service.
service ssl	Set up an ssl service.
service ssl-vlan	Set up an ssl-vlan service.
service tcp-dos-params	Set up a tcp-dos-params service.
service tcp-handoff-params	Set up a tcp-handoff-params service.
service tcp-params	Set up a tcp-params service.

service tracking	Set up tracking for a service.
service vlan	Set up a VLAN service.
show	Display commands.
show arp	Display all the entries in the ARP table.
show boot option	Display the current and next boot options.
show build status	Display the status of the build.
show date	Display the current system date and time.
show default tcp	Display default tcp protocol.
show default tcp-params	Display default tcp parameters.
show default tcp-dos-params	Display default tcp security parameters.
show default tcp-handoff-params	Display default tcp handoff parameters.
show gateway	Display default gateway.
show image	Display WHAT image.
show images	Display WHAT images.
show interface	Display current interface (0 or 1).
show ip	Display administration port ip address.
show last build status	Display the previous build status.
show network	Display the network.
show real service	Display real services.
show service lb-group	Display the service defined for the load balancing group.
show service lb-group server	Display the load balancing group server.
show ssl	Display the security blade.
show system	Display the current system settings.
show tasks	Display the current active tasks.
show uptime	Display the uptime for the system.
show version	Display the version of the software in use.

show vip	
ssl-blade	Display the security blade.
shutdown	Perform a graceful shutdown of the system.
shutdown force	Force the shutdown without asking for confirmation.
ssl-blade	Configure an ssl blade.
ssl-blade port pair	Configure an ssl port pair.
stty hardwrap	Turns on hardwrap on the console.
stty status	Displays the console settings.

T

tar	Utility that collapses all the files under the specified directory into one tar file.
tarinfo	Displays the contents of the specified tar file.
tree	Display all the content load balancing blade commands.

U

untar	Utility that extracts all the files from the specified tar file into the current directory.
update image	Download a new boot image over the network and write it into flash.
uptime	Display the amount of uptime.
user add	Add a new user to the system.
user delete	Delete a user.
user show	List all users currently existing in the system, along with their respective access level.

V

vip-netmask Configure the VIP netmask.

W

who Display all current users.

whoami Display current user, mode, and system information.

Glossary

- ARP** The Address Resolution Protocol (ARP) conceptually exists between the data link and Internet layers. ARP assists IP in directing datagrams to the appropriate receiving host by mapping Ethernet addresses (48 bits long) to known IP addresses (32 bits long).
- Bandwidth** The difference between the highest and lowest frequencies available for network signals. Also synonymous with wire speed, the actual speed of the data transmission along the cable.
- Blade** A single board computer associated with an enclosure system that allows multiple blades to be housed in a standard server subrack, or enclosure, sharing resources such as power supplies and cooling fans. The server blade architecture is designed for computing density using a modular architecture for flexibility and scalability.
- BSC** The Blade Support Chip is an H8 micro-controller that integrates a number of different communication mechanisms and provides low-level support for a number of functions.
- Ethernet** A network communication system developed and standardized by DEC, Intel, and Xerox, using baseband transmission, CSMA/CD access, logical bus topology, and coaxial cable. The successor IEEE 802.3 standard provides for integration into the OSI model and extends the physical layer and media with repeaters and implementations that operate on fiber, thin coax, and twisted-pair cable.
- Fast Ethernet** A 100 Mbps network communication system based on Ethernet and the CSMA/CD access method.
- Full Duplex** Transmission method that allows switch and network card to transmit and receive concurrently, effectively doubling the bandwidth of that link.
- FTP** The File Transfer Protocol (FTP) transfers files to and from a remote network. The protocol includes the ftp command (local machine) and the in.ftpd daemon (remote machine). FTP enables a user to specify the name of the remote host and file transfer command options on the local host's command line. The in.ftpd daemon on the remote host then handles the requests from the local

host. Unlike rcp, ftp works even when the remote computer does not run a UNIX-based operating system. A user must log in to the remote computer to make an ftp connection unless it has been set up to allow anonymous FTP.

Gigabit Ethernet A 1000 Mbps network communication system based on Ethernet and the CSMA/CD access method.

ICMP Internet Control Message Protocol (ICMP) is the protocol responsible for detecting network error conditions and reporting on them. ICMP reports on: dropped packets (when packets are arriving too fast to be processed); connectivity failure (when destination host cannot be reached); redirection (which tells a sending host to use another router).

IPMP IP multipathing is a network load spreading and failover framework for Solaris hosts with multiple network interfaces connected to the same IP link.

**Local Area Network
(LAN)**

A group of interconnected computer and support devices

Layer 4 The transport layer in the ISO 7-Layer Data Communications Protocol. This layer manages the transfer of data and assures that received and transmitted data are identical.

Layer 7 The application layer in the ISO 7-Layer Data Communications Protocol. This layer consists of standard communication services and applications that everyone can use.

LED Light emitting diode used for monitoring a device or network condition.

Multi-homed host In the internet environment, a single machine connected to multiple data links, which may be on different networks.

N1 Sun's vision, architecture, and products for the next-generation data center as to how to aggregate and automate distributed resources including provisioning and virtualization.

NPU Network Processor Unit. All software on the NPU deals with packet processing in the data path.

Round robin A load balancing scheme that distributes incoming data, using each network interface in turn.

Static Load Balancing A scheme for distributing requests to servers where the server selection is based on static attributes of the requesting client, for example geographic location, IP addresses, and so on.

Sun Fire B1600 A platform for horizontally scalable applications that do not depend upon symmetric multi-processing to provide increased performance in a multiprocessor environment. Horizontally scaled systems achieve higher performance by dividing the application load from the clients between

replicated application instances each running its own server. Each blade is a server meeting this requirement running its own instance of the operating system plus its own network application.

Sun ONE Sun Open Net Environment (Sun ONE) is an open framework that supports web services today and lays the foundation for the smart web services of tomorrow. Sun ONE enables organizations to create, assemble, and deploy smart web services.

Telnet The Telnet protocol enables terminals and terminal-oriented processes to communicate on a network running TCP/IP.

TFTP The trivial file transfer protocol (tftp) provides functions similar to ftp, but it does not establish ftp's interactive connection. As a result, users cannot list the contents of a directory or change directories. This means that a user must know the full name of the file to be copied. The tftp(1) man page describes the tftp command set.

Virtual LAN (VLAN) A Virtual LAN is a collection of network nodes that are the same broadcast domain regardless of their physical location or connection point in the network. A VLAN serves a logical workgroup with no physical barriers and allows users to share information and resources as though located on the same LAN.

Weighted round robin A method of distributing incoming data that allows administrators to assign how much traffic a server can handle relative to the other servers in the same group. Administrators can choose these weights based on server characteristics, such as number of CPUs or CPU speed.

Index

NUMERICS

10/100/1000BASE-T Data Network Port
Pinouts, 22

B

build rules command, 84

C

config default tcp-params command, 56
config http-rule command, 82
config ip interface command, 44
config ip-rule command, 80
config server-monitor, 51
config service lb-group default command, 59
config ssl name command, 52
create a load balancing group, 85

D

data vlan, 124
data vlan command, 124
default gateway, 48
default tcp-handoff-params command, 58
default vlan command, 124

E

enable server command, 78
enable service command, 77
enable ssl name command, 55
enable vlan command, 124
export config command, 106

H

hardware and software requirements, 3
hardware installation, 15
help command, 120

I

import config command, 106
IP address
 configuring, 44

L

LED status codes, 20
login, 41
logout, 41

M

management vlan, 125

management vlan command, 124
monitoring the server, 51

N

no build rules command, 85
no enable server command, 79
no enable service command, 77
no enable vlan command, 129
no service ip-persist command, 72

P

ports
 location of, 20
power off a blade, 26
power on a blade, 24

R

remove rule command, 83
remove service cookie-persist, 76
remove service lb-group command, 93
remove service lb-group rule command, 89
remove service lb-group server command, 91
remove service name command, 78
remove service point, 69
remove ssl if command, 54
remove ssl port-pair command, 53

S

serial port
 pin numbers, 23
server monitoring, 51
server-monitor command, 51
service, 59
service cookie-persist command, 75
service ip-persist command, 70
service lb-group command, 85
service lb-group default command, 64
service lb-group rule command, 88

service lb-group server command, 90
service point command, 68
service ssl command, 61
service tcp-handoff-params command, 67
service tracking command, 72, 73
show arp command, 49
show build rules command, 84
show default tcp command, 58
show last build status command, 85
show network, 47
show network command, 49
show rule command, 95
show server command, 97
show service command, 94
show service-lb-group command, 96
show ssl command, 55
show vip command, 50
shut down
 orderly, 26
shutdown
 forcing, 27
ssl port-pair command, 53, 54
standby mode, 27

T

TFTP, 131
 setting up a TFTP server, 132

V

VLANs, 6