

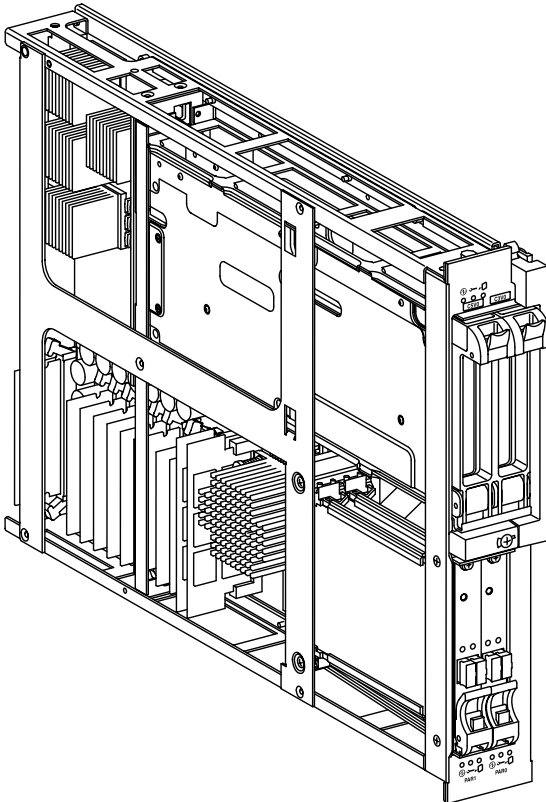

Sun Fire™ Link Assembly Installation Guide for Sun Fire 15K/12K Systems



This doclette provides instructions for installing a Sun Fire Link assembly in a Sun Fire 6800 chassis.

Complete documentation for the Sun Fire Link interconnect product is available in two formats:

- In a printed version, which you can order (part number, X4190A)
- In Adobe Acrobat Exchange (.pdf) format on the Sun Fire Link CD. The CD ships with:
 - Sun Fire Link Assembly (Sun Fire 6800 system)
 - Sun Fire Link Assembly (Sun Fire 15K/12K system)

To read the documentation online, use the CD-ROM drive on the workstation that serves as your administration station.

Installing a Sun Fire Link Assembly

These instructions are for use by trained service representatives who have been trained on Sun Fire Link interconnect hardware, and who have previously installed a Sun Fire Link assembly in the field. They are not complete instructions; they lack illustrations and precautions.

Note – These instructions are intended only as a reminder for those who have previous experience with this procedure. See the Sun Fire Link Hardware Installation Guide for more detailed instructions.

1. **Attach an ESD wrist strap or foot strap, and connect the strap to the system. Place an ESD mat close to the system.**



Caution – You must install an assembly within one minute of removing the filler panels.

2. **Remove a filler panel, if one is installed in the slot.**
3. **Hold the assembly by the front handle with one hand, while supporting the bottom with your other hand, and position the board onto the carrier rail.**
4. **With the ejector lever extended, slide the assembly into the slot until it connects with the expander connector.**
5. **Apply firm pressure to the face plate to properly seat the assembly with the expander connector.**
6. **Push the ejector lever downwards to fully seat the assembly.**

Accessing Sun Documentation Online

A broad selection of Sun system documentation is located at:

<http://www.sun.com/products-n-solutions/hardware/docs>

A complete set of Solaris documentation and many other titles are located at:

<http://docs.sun.com>

Sun Welcomes Your Comments

Sun is interested in improving its documentation and welcomes your comments and suggestions. You can email your comments to Sun at:

docfeedback@sun.com

Please include the part number (816-2795-11) of the document in the subject line of your email.

Copyright 2003 Sun Microsystems, Inc. All rights reserved. Use is subject to license terms. Third-party software, including font technology, is copyrighted and licensed from Sun suppliers. Portions may be derived from Berkeley BSD systems, licensed from U. of CA. Sun, Sun Microsystems, the Sun logo, Sun Fire, and Solaris are trademarks or registered trademarks of Sun Microsystems, Inc. in the U.S. and in other countries. All SPARC trademarks are used under license and are trademarks or registered trademarks of SPARC International, Inc. in the U.S. and in other countries. U.S. Government Rights—Commercial use. Government users are subject to the Sun Microsystems, Inc. standard license agreement and applicable provisions of the FAR and its supplements.

Copyright 2003 Sun Microsystems, Inc. Tous droits réservés. Distribué par des licences qui en restreignent l'utilisation. Le logiciel détenu par des tiers, et qui comprend la technologie relative aux polices de caractères, est protégé par un copyright et licencié par des fournisseurs de Sun. Des parties de ce produit pourront être dérivées des systèmes Berkeley BSD licenciés par l'Université de Californie. Sun, Sun Microsystems, le logo Sun, Sun Fire, et Solaris sont des marques de fabrique ou des marques déposées de Sun Microsystems, Inc. aux Etats-Unis et dans d'autres pays. Toutes les marques SPARC sont utilisées sous licence et sont des marques de fabrique ou des marques déposées de SPARC International, Inc. aux Etats-Unis et dans d'autres pays.



Sun Microsystems, Inc.
www.sun.com