

When installing a Rack-Ready Sun Enterprise 4500 server in a Sun Enterprise System Cabinet or Sun StorEdge Expansion Cabinet, refer to the *Rackmount Placement Matrix* for storage device restrictions at the following website,

<http://docs.sun.com:80/ab2/coll.242.1/RACKMNTMTRX>

## Air Baffle Requirements

When installing chassis in a rack, you must adhere to certain baffle requirements.

For the Sun Enterprise System Cabinet,

- When installing *three* Sun Enterprise 4500s, you must install the 9-inch Sun Enterprise Cabinet Air Baffle (part number X9601A) along with the 6-inch Sun Enterprise Air Baffle (part number 9625A).
- When installing *four* Sun Enterprise 4500s in a rack, only the 6-inch Sun Enterprise Air Baffle (part number 9625A) is required.

For the Sun StorEdge Expansion Cabinet,

- an Air Baffle Kit (part number X9660A) is required above the topmost Sun Enterprise 4500.

## Inventory

The rack-mounting kit contains,

- Sun Enterprise 4500 System
- Left rail
- Right rail
- 10-32 x 1/2 inch (16)

## Installing the Rack Rails

### 1. Attach the left rail to the rack,

- Refer to the *Rackmount Placement Matrix* to determine which mounting holes you will use. The screw holes on the rack are numbered for easy identification.**
- Loosely fit the two top screws in the left side of the rack.**

### c. Slide the rail onto the screws.

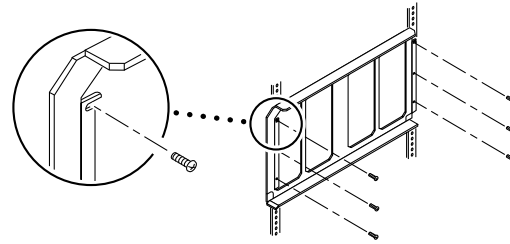

### d. Install the four remaining screws, then tighten all six screws.

### 2. Install the right rail in the same manner.

## Installing the Server Chassis

### 1. Remove the front door of the cabinet.

- Lift the door off the hinge pins on the Sun Enterprise System Cabinet.
- Remove the plastic strips from the shelf(s) of the Sun StorEdge Expansion Cabinet.

### 2. Lower the leveling pads to ensure that the cabinet cannot move.



**Caution** – The chassis is heavy. In the following procedures, two people are required to move the chassis.

### 3. Two people must lift and slide the chassis onto the rails.

For the Sun Enterprise System Cabinet, the chassis is recessed a few inches into the cabinet.

For the Sun StorEdge Expansion Cabinet, the chassis is flush with the front of the cabinet.

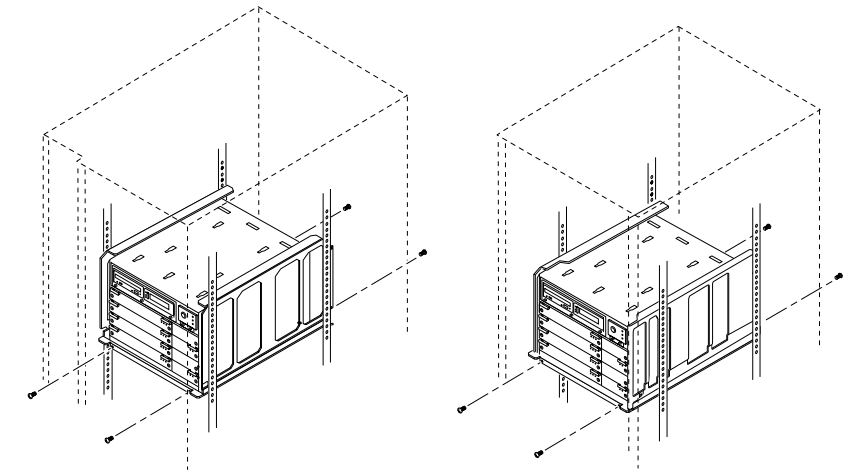

Rack-Ready Sun Enterprise 4500 in a Sun Enterprise System cabinet

Rack-Ready Sun Enterprise 4500 in a Sun StorEdge Expansion cabinet

### 4. Secure the base plate to the side rails with four 10-32 x 1/2 inch screws, two screws at the front and two screws at the rear.

### 5. Connect the chassis to the power sequencer.

For the Sun Enterprise System Cabinet:

- For chassis 1, disconnect the AC cable of the rack fan tray from socket J2 and connect the AC cable to J6, then connect the chassis to socket J2.
- For chassis 2, connect to socket J7.
- For chassis 3, connect to socket J11.
- For chassis 4, connect to socket J2 of the second power sequencer.

For the Sun StorEdge Expansion Cabinet:

- For chassis 1, connect to socket J7 of the first power sequencer.
- For chassis 2, connect to socket J12 of the first power sequencer.
- For chassis 3, connect to socket J7 of the second power sequencer.
- For chassis 4, connect to socket J12 of the second power sequencer.

### 6. Route the interface cables as appropriate and connect them to the Sun Enterprise 4500 chassis.

### 7. Replace the front door.

---

## Ordering Sun Documentation

Fatbrain.com, an Internet professional bookstore, stocks select product documentation from Sun Microsystems, Inc. For a list of documents and how to order them, visit the Sun Documentation Center on Fatbrain.com at,

<http://www1.fatbrain.com/documentation/sun>

## Sun Welcomes Your Comments

Sun is interested in improving its documentation and welcomes your comments and suggestions. You can email your comments to Sun at,

[docfeedback@sun.com](mailto:docfeedback@sun.com)

Please include the part number (806-5927-10) of the document in the subject line of your email.

Copyright 2000 Sun Microsystems, Inc. All rights reserved. Use is subject to license terms. Third-party software, including font technology, is copyrighted and licensed from Sun suppliers. Sun, Sun Microsystems, the Sun logo, AnswerBook2, docs.sun.com, Sun StorEdge, and Solaris are trademarks or registered trademarks of Sun Microsystems, Inc. in the U.S. and other countries. **RESTRICTED RIGHTS.** Use, duplication, or disclosure by the U.S. Government is subject to restrictions of FAR 52.227-14(g)(2)(6/87) and FAR 52.227-19(6/87), or DFAR 252.227-7015(b)(6/95) and DFAR 227.7202-3(a).

Copyright 2000 Sun Microsystems, Inc. Tous droits réservés. Distribué par des licences qui en restreignent l'utilisation. Le logiciel détenu par des tiers, et qui comprend la technologie relative aux polices de caractères, est protégé par un copyright et licencié par des fournisseurs de Sun. Sun, Sun Microsystems, le logo Sun, AnswerBook2, docs.sun.com, et Solaris sont des marques de fabrique ou des marques déposées de Sun Microsystems, Inc. aux Etats-Unis et dans d'autres pays.



Please Recycle

Sun Microsystems, Inc. • 901 San Antonio Road • Palo Alto, CA 94303-4900  
USA • 650 960-1300 • Fax 650 969-9131



Part Number, 806-5927-10  
June 2000, Revision A



---

# Rack-Ready Sun Enterprise™ 4500 Server Rackmounting Guide

*for the Sun Enterprise System Cabinet and  
the Sun StorEdge™ Expansion Cabinet*

