



Netra t1 4-Stack Memory Upgrade

Addendum

Sun Microsystems, Inc.
901 San Antonio Road
Palo Alto, CA 94303
U.S.A. 650-960-1300

Part No. 806-5606-10
June 2000, [Revision A](#)

[Send comments about this document to: docfeedback@sun.com](mailto:docfeedback@sun.com)

Copyright 2000 Sun Microsystems, Inc., 901 San Antonio Road • Palo Alto, CA 94303-4900 USA. All rights reserved.

This product or document is protected by copyright and distributed under licenses restricting its use, copying, distribution, and decompilation. No part of this product or document may be reproduced in any form by any means without prior written authorization of Sun and its licensors, if any. Third-party software, including font technology, is copyrighted and licensed from Sun suppliers.

Parts of the product may be derived from Berkeley BSD systems, licensed from the University of California. UNIX is a registered trademark in the U.S. and other countries, exclusively licensed through X/Open Company, Ltd. For Netscape Communicator™, the following notice applies: Copyright 1995 Netscape Communications Corporation. All rights reserved.

Sun, Sun Microsystems, the Sun logo, AnswerBook2, docs.sun.com, Netra and Solaris are trademarks, registered trademarks, or service marks of Sun Microsystems, Inc. in the U.S. and other countries. All SPARC trademarks are used under license and are trademarks or registered trademarks of SPARC International, Inc. in the U.S. and other countries. Products bearing SPARC trademarks are based upon an architecture developed by Sun Microsystems, Inc.

The OPEN LOOK and Sun™ Graphical User Interface was developed by Sun Microsystems, Inc. for its users and licensees. Sun acknowledges the pioneering efforts of Xerox in researching and developing the concept of visual or graphical user interfaces for the computer industry. Sun holds a non-exclusive license from Xerox to the Xerox Graphical User Interface, which license also covers Sun's licensees who implement OPEN LOOK GUIs and otherwise comply with Sun's written license agreements.

RESTRICTED RIGHTS: Use, duplication, or disclosure by the U.S. Government is subject to restrictions of FAR 52.227-14(g)(2)(6/87) and FAR 52.227-19(6/87), or DFAR 252.227-7015(b)(6/95) and DFAR 227.7202-3(a).

DOCUMENTATION IS PROVIDED "AS IS" AND ALL EXPRESS OR IMPLIED CONDITIONS, REPRESENTATIONS AND WARRANTIES, INCLUDING ANY IMPLIED WARRANTY OF MERCHANTABILITY, FITNESS FOR A PARTICULAR PURPOSE OR NON-INFRINGEMENT, ARE DISCLAIMED, EXCEPT TO THE EXTENT THAT SUCH DISCLAIMERS ARE HELD TO BE LEGALLY INVALID.

Copyright 2000 Sun Microsystems, Inc., 901 San Antonio Road • Palo Alto, CA 94303-4900 Etats-Unis. Tous droits réservés.

Ce produit ou document est protégé par un copyright et distribué avec des licences qui en restreignent l'utilisation, la copie, la distribution, et la décompilation. Aucune partie de ce produit ou document ne peut être reproduite sous aucune forme, par quelque moyen que ce soit, sans l'autorisation préalable et écrite de Sun et de ses bailleurs de licence, s'il y en a. Le logiciel détenu par des tiers, et qui comprend la technologie relative aux polices de caractères, est protégé par un copyright et licencié par des fournisseurs de Sun.

Des parties de ce produit pourront être dérivées des systèmes Berkeley BSD licenciés par l'Université de Californie. UNIX est une marque déposée aux Etats-Unis et dans d'autres pays et licenciée exclusivement par X/Open Company, Ltd. La notice suivante est applicable à Netscape Communicator™: Copyright 1995 Netscape Communications Corporation. Tous droits réservés.

Sun, Sun Microsystems, the Sun logo, AnswerBook2, docs.sun.com, Netra et Solaris sont des marques de fabrique ou des marques déposées, ou marques de service, de Sun Microsystems, Inc. aux Etats-Unis et dans d'autres pays. Toutes les marques SPARC sont utilisées sous licence et sont des marques de fabrique ou des marques déposées de SPARC International, Inc. aux Etats-Unis et dans d'autres pays. Les produits portant les marques SPARC sont basés sur une architecture développée par Sun Microsystems, Inc.

L'interface d'utilisation graphique OPEN LOOK et Sun™ a été développée par Sun Microsystems, Inc. pour ses utilisateurs et licenciés. Sun reconnaît les efforts de pionniers de Xerox pour la recherche et le développement du concept des interfaces d'utilisation visuelle ou graphique pour l'industrie de l'informatique. Sun détient une licence non exclusive de Xerox sur l'interface d'utilisation graphique Xerox, cette licence couvrant également les licenciés de Sun qui mettent en place l'interface d'utilisation graphique OPEN LOOK et qui en outre se conforment aux licences écrites de Sun.

CETTE PUBLICATION EST FOURNIE "EN L'ETAT" ET AUCUNE GARANTIE, EXPRESSE OU IMPLICITE, N'EST ACCORDEE, Y COMPRIS DES GARANTIES CONCERNANT LA VALEUR MARCHANDE, L'APTITUDE DE LA PUBLICATION A REpondre A UNE UTILISATION PARTICULIERE, OU LE FAIT QU'ELLE NE SOIT PAS CONTREFAISANTE DE PRODUIT DE TIERS. CE DENI DE GARANTIE NE S'APPLIQUERAIT PAS, DANS LA MESURE OU IL SERAIT TENU JURIDIQUEMENT NUL ET NON AVENU.



Installing Four 256 Mbyte Memory Boards

This document tells you how to install a stack of four 256 Mbyte memory boards into the Netra t1 system. If you want to install a single additional 256 Mbyte memory board, follow the instructions in the *Netra t1 Systems Memory Upgrade* document (part number 806-2129-11).



Note – Do not install memory boards in stacks of three. If you do not want to install boards in a 4-stack configuration, you can install them in single-board or 2-stack configurations. In a 2-stack configuration, you can combine Netra t1 memory boards of different capacities (64, 256, or 512 Mbytes).

This document contains the following sections:

- “Materials and Tools Required” on page 2
- “Wearing an Anti-Static Wrist Strap” on page 3
- “Installing the Stack of Four Boards” on page 4

Materials and Tools Required



Note – The boards you must use for the 4-stack memory installation have the part number 370-4155. Other 256 Mbyte memory boards (those with part numbers 370-4096 and 595-5097) cannot be included in a 4-stack configuration. The boards you must use are identifiable by a sticky label saying '4-stack only'.

The packaging containing your 4-stackable 256 Mbyte memory board includes a kit (part number 540-4532-02) containing the following (see FIGURE 1):

- Four square spacers
- Four lock washers
- Four flat washers
- Four long screws (11/16 inch; required only for 4-stack configurations)
- Four round plastic spacers (required only for 2-stack configurations)
- Four short screws (3/16 inch; required only for single-board configurations)
- Four medium length screws (3/8 inch; required only for 2-stack configurations)
- Four medium length screws (3/8 inch; required only for 2-stack configurations)

To install a stack of four boards, you need four memory board packages. To order a single package from your Sun Enterprise Services representative, quote the sales part number X6985A.

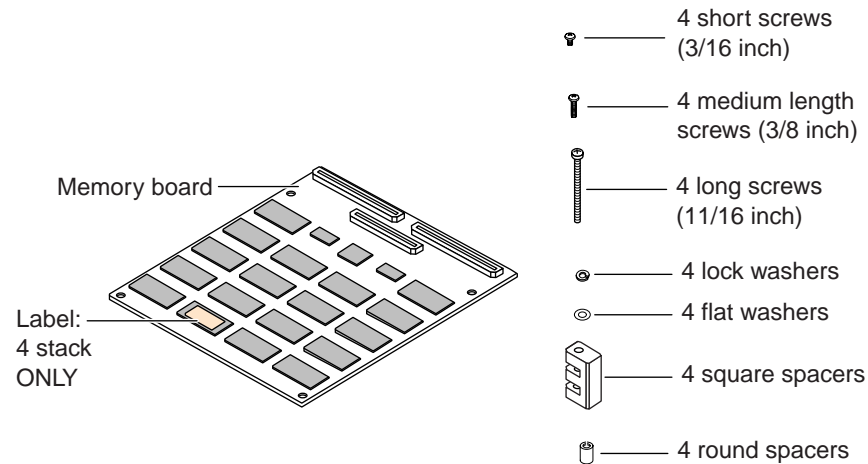

FIGURE 1 The 4-Stackable Memory Board Kit

Wearing an Anti-Static Wrist Strap



Caution – The Netra t1 system contains electronic parts that are extremely sensitive to static electricity. Do not touch any metal parts. Wear an anti-static wrist strap connected to an earthing point before you open the system.

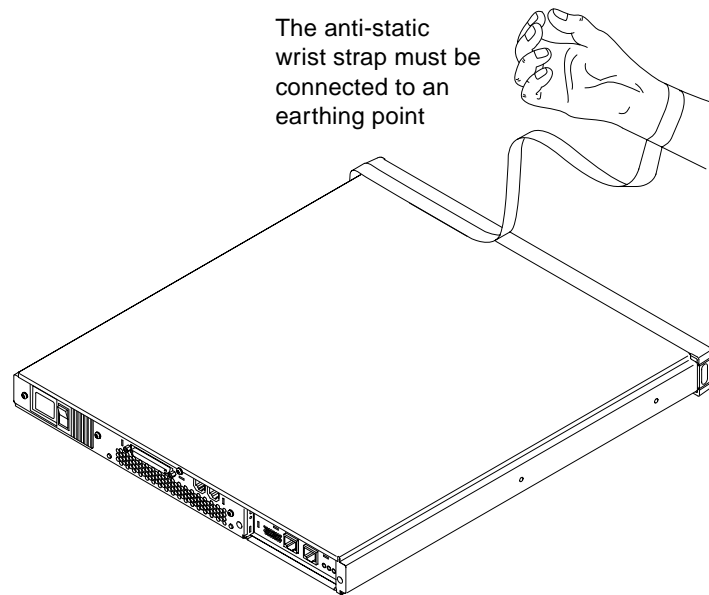

FIGURE 2 Preparing to Open the System Wearing an Anti-Static Wrist Strap

Installing the Stack of Four Boards

1. If your system is new and you have just removed it from its packaging, go straight to Step 3. If your system is currently in use, then:
 - a. Shut down Solaris from the console.
 - b. Turn the power supply switch off.
 - c. Disconnect the power cord or power cords.
 - d. Disconnect all other cables.
2. If you have installed the system into a rack or cabinet, remove it.
3. Remove the rack mount brackets from the side of the system (see FIGURE 3).

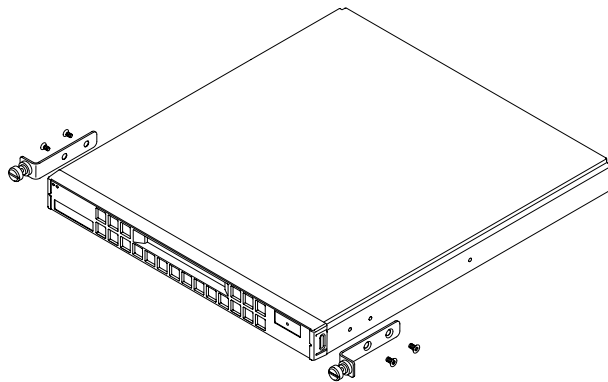

FIGURE 3 Removing the Rack Mount Brackets from the Side of the System

4. Place the unit at an ESD station and make sure you are wearing an anti-static wrist strap connected to an earthing point.



Caution – Before attempting to remove the top cover of the Netra t1 system, make sure that all power cords and all other cables have been disconnected.

5. Remove the system's top cover (see FIGURE 4). To do this:
 - a. Remove the screw at the rear center of the unit.
 - b. Slide the top cover back and lift it off.

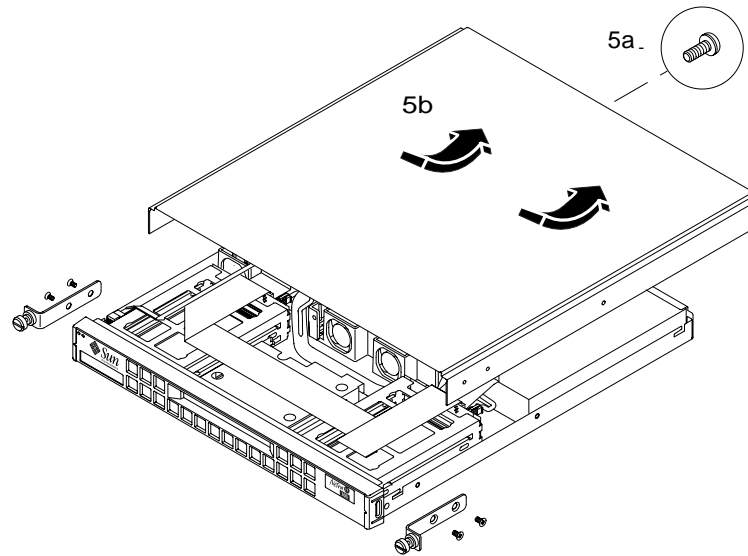

FIGURE 4 Removing the Top Cover of the Netra t1 System

- 6. Lift out the processor cover located in the rear center of the unit (see FIGURE 5).**
Make sure you slide the processor cover tabs from under the rear I/O card before lifting the processor cover away from the system.

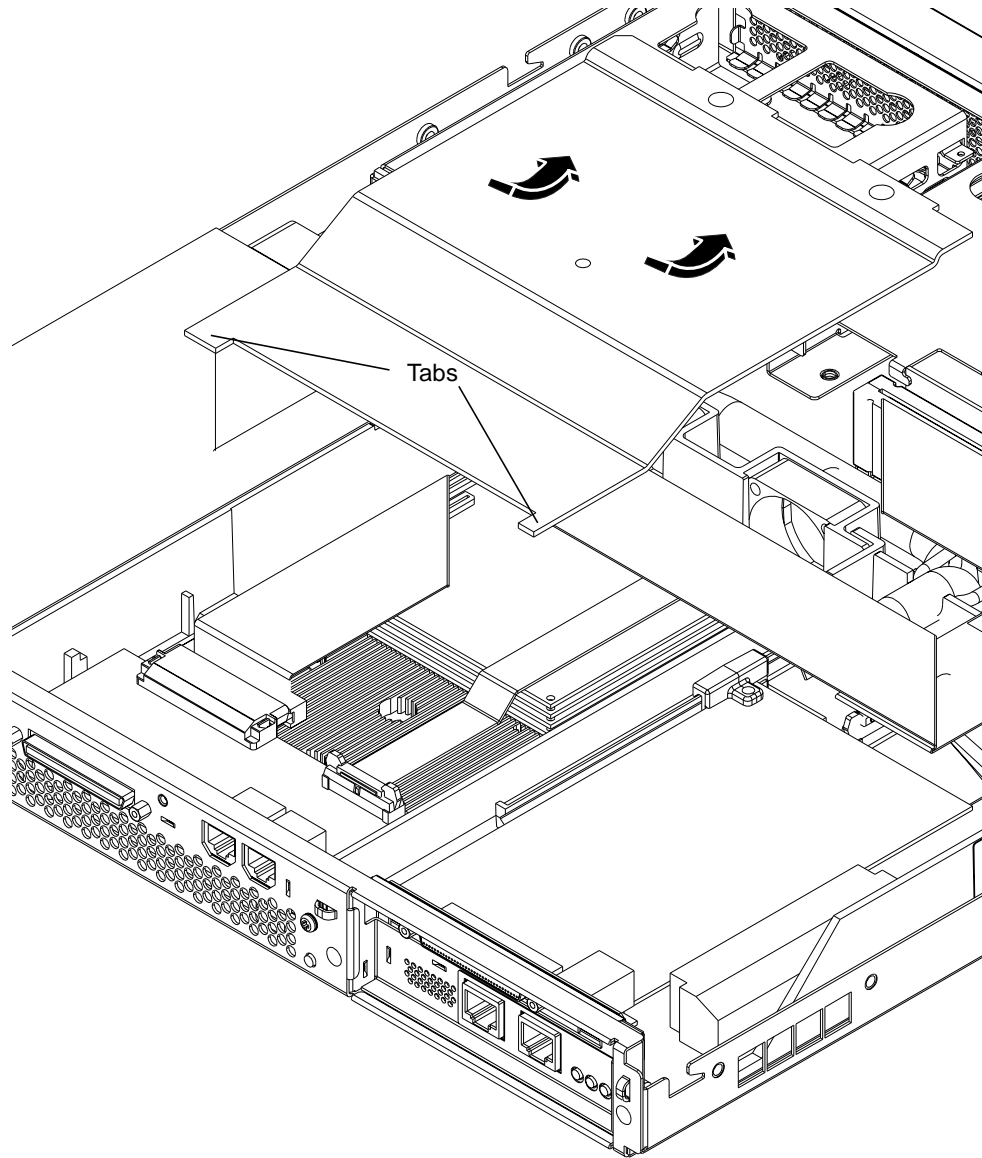

FIGURE 5 Lifting out the Processor Cover

7. Using a Phillips No.1 screwdriver, remove the screws and washers from the base memory board (see FIGURE 6).

If you intend to replace the base memory board, lift out the board that is currently installed. Otherwise, leave the current board seated in the connectors on the motherboard but not screwed in.



Note – If you are making a 4-stack (1 Gbyte) configuration, the base board and all other boards in the stack must be of part number 370-4155.

For purposes of illustration, the board you use as the base board will be called Board A, Board B will be the board you put on top of Board A, Board C will be the one you put on top of Board B, and Board D will be the one at the top of the stack.

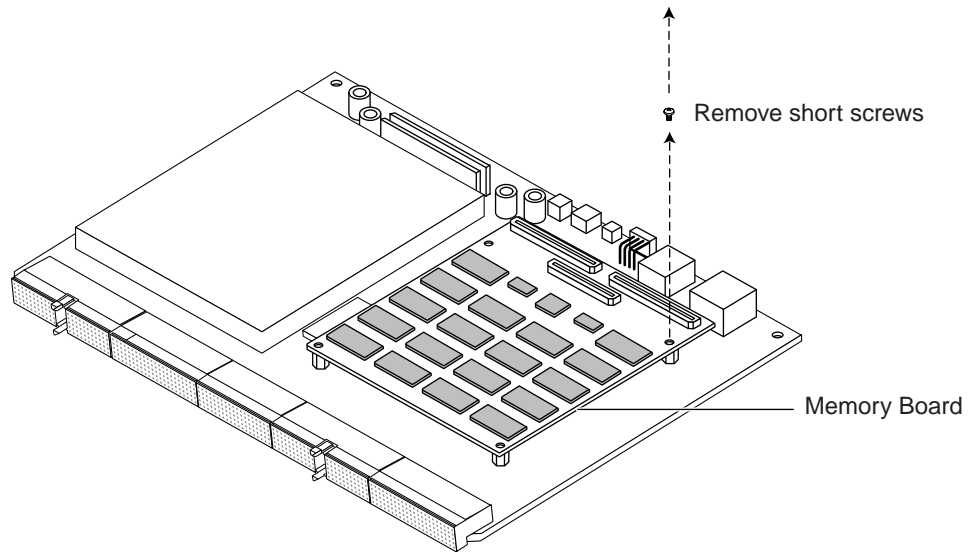

FIGURE 6 Removing the Mounting Screws from the Currently Installed Memory Board

8. If you are replacing the currently installed base memory board, align the connectors of the new base board with the memory board sockets on the Netra t1's motherboard.

Press home fully the connectors using your thumbs. The connectors need to be properly seated (see FIGURE 7). You might find it helpful to seat the middle connector properly before the other two connectors.

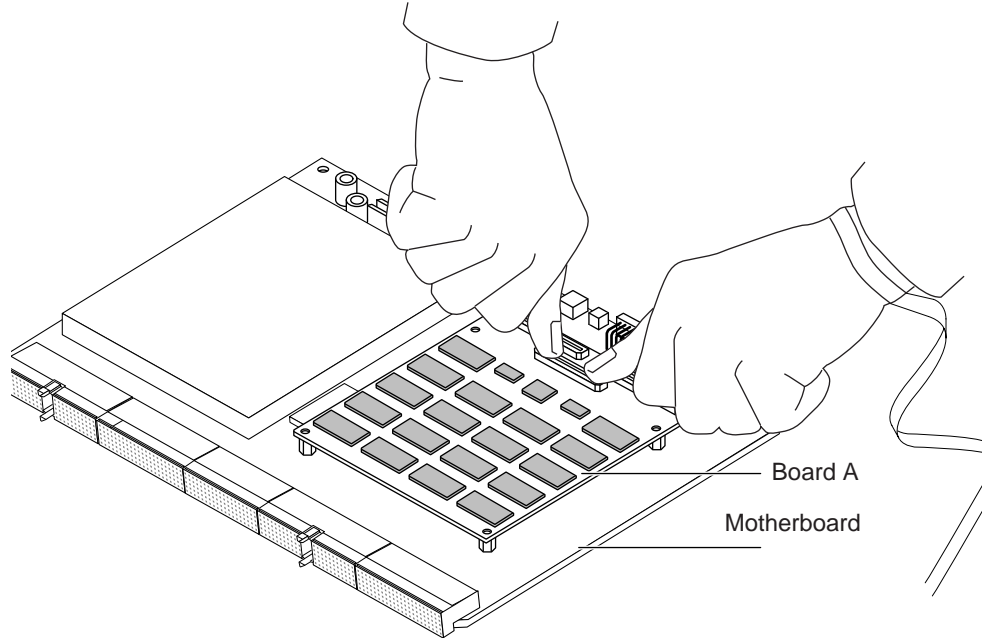

FIGURE 7 Seating a Single Memory Board on the Netra t1's Motherboard



Caution – Although it is necessary for the connectors to be properly seated, you must not apply excessive pressure to them. If you do, you might cause microfractures on the motherboard which can impair the operation of the board.

9. Position the connectors of one memory board (Board C) above the memory board connector sockets of another memory board (Board B) in a piggy-back style, then press down the connectors using your thumbs until they are seated.

You might find it helpful to seat the middle connector properly first. See FIGURE 8. Put together Boards B and C first, *before* you connect them to Board A.



Caution – Place the memory boards on ESD foam during this assembly.

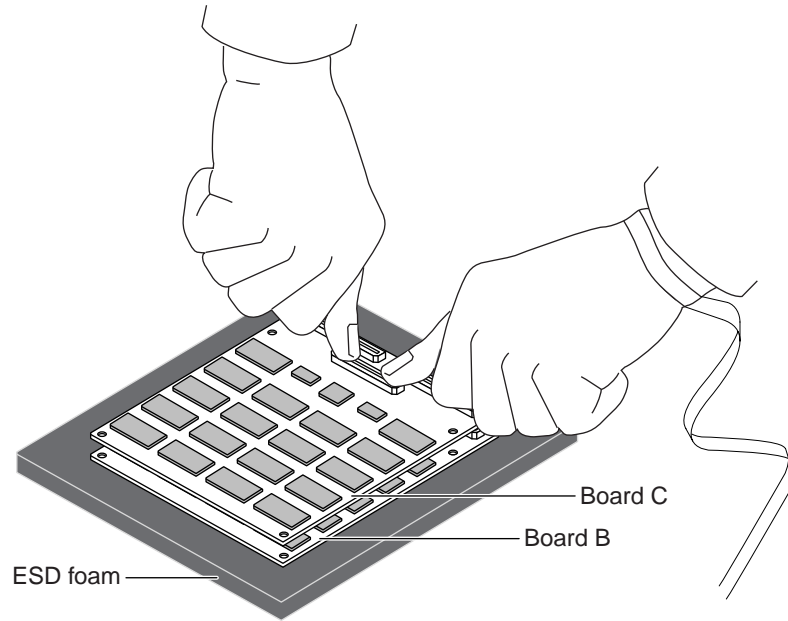

FIGURE 8 Stacking the Third Memory Board on Top of the Second

10. Insert the four plastic spacers and align them with the mounting holes on memory Boards B and C (see FIGURE 9).

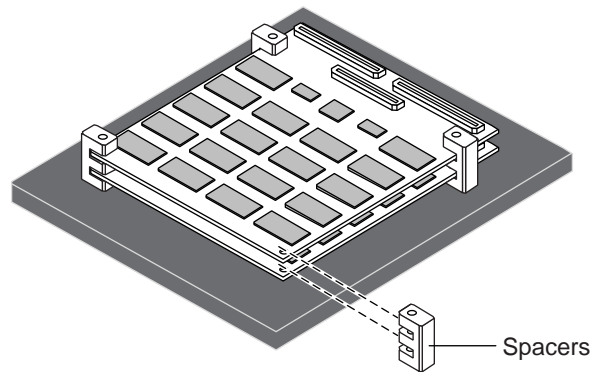

FIGURE 9 Aligning the Four Plastic Spacers with the Mounting Holes

11. Carefully transport the memory boards (Boards B and C) with spacers onto Board A (see FIGURE 10).

Follow the procedure described in Step 9 to mount the assembled Boards B and C (with spacers inserted) onto memory Board A.

Hold the spacers, if necessary, so that they do not move out of position.

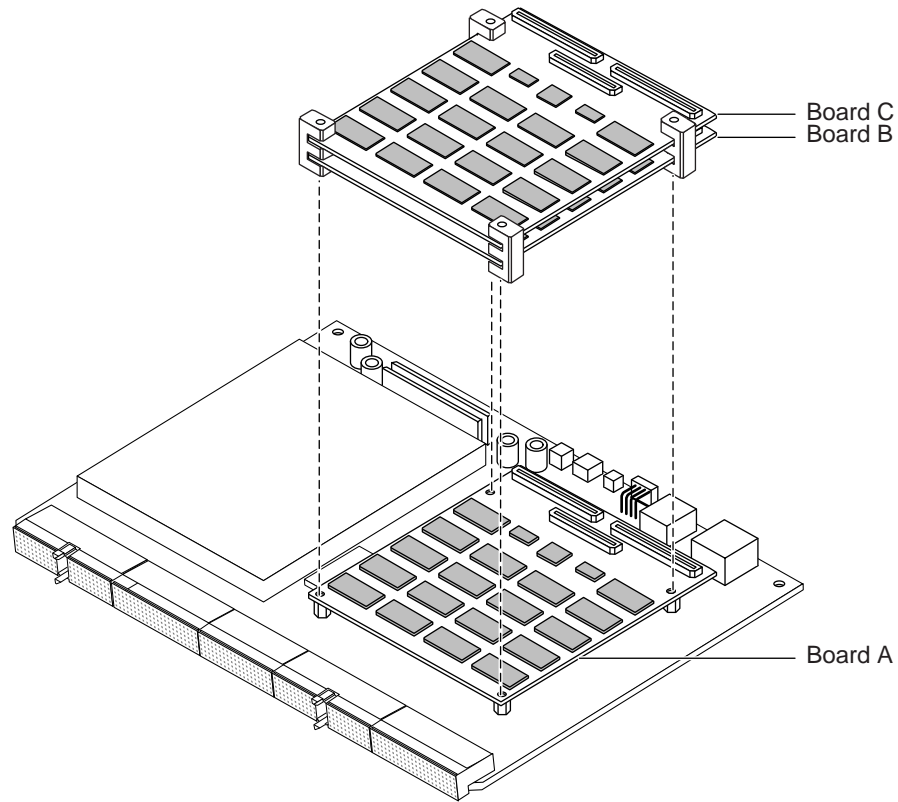

FIGURE 10 Mounting the Second and Third Boards onto the Base Memory Board

12. Align the connectors of Board D to the sockets of Board C, but do not press down yet to seat Board D (see FIGURE 11).

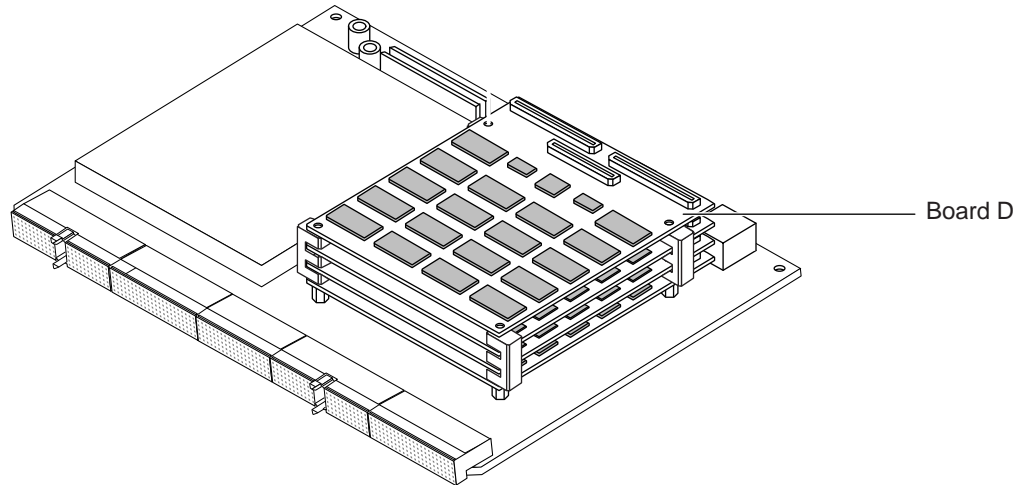

FIGURE 11 Four Stacked Memory Boards on the Netra t1 Motherboard

13. **Insert each screw into one lock washer and one flat washer, then drop the screws (with the washers) into the aligned mounting holes of the memory boards and the plastic spacers (see FIGURE 12).**

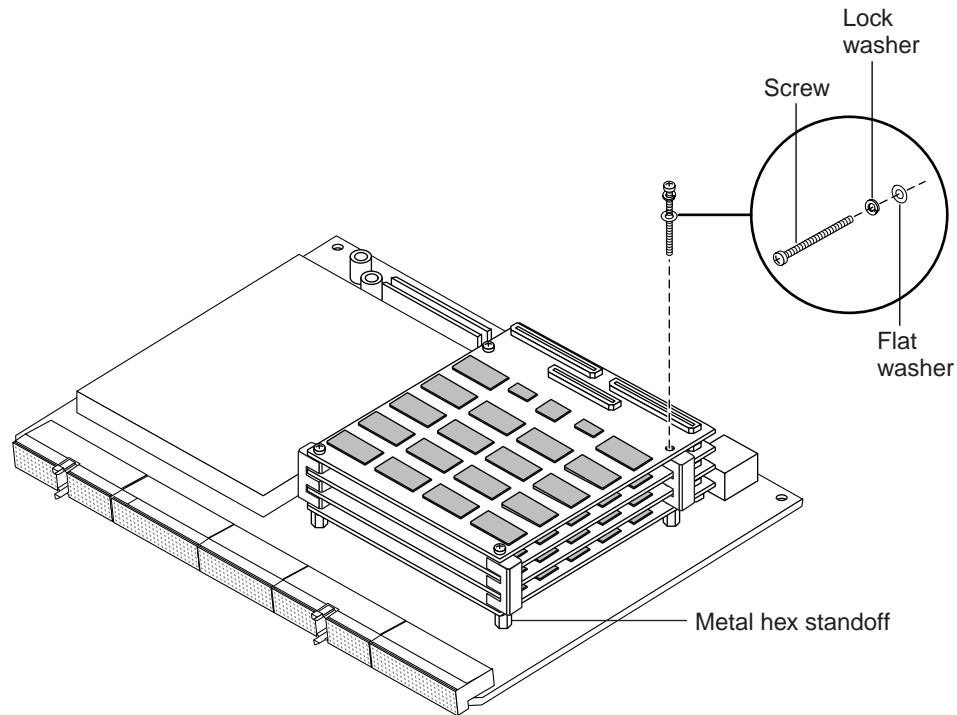

FIGURE 12 Dropping the Screws into the Aligned Mounting Holes

14. **Using your fingers, turn all four screws until they take up just the first one or two threads in the metal hex standoffs (see FIGURE 12)**

This helps to align the connectors of Board D with the sockets of Board C, preventing any sideways movement of the stack when you press home the connectors of Board D.

15. **Now press home fully the connectors of Board D. You might find it helpful to seat the middle connector properly before the other two connectors.**

16. **Tighten the screws into the metal hex standoffs so that the stack sits firmly on the motherboard.**

Tighten each screw a little at a time to avoid bending and possibly damaging any of the boards. (The recommended tightening torque is 0.3 Nm.)

17. **Replace the processor cover which you removed in Step 6.**

Make sure that you put the tabs on the processor cover back into their original position underneath the rear I/O card.