



Sun Fire™ 15K/12K Systems

Hardware Installation and De-Installation Guide

Sun Microsystems, Inc.
www.sun.com

Part No. 806-3511-12
June 2003, Revision A

Submit comments about this document at: <http://www.sun.com/hwdocs/feedback>

Copyright 2003 Sun Microsystems, Inc., 4150 Network Circle, Santa Clara, California 95054, U.S.A. All rights reserved.

Sun Microsystems, Inc. has intellectual property rights relating to technology embodied in the product that is described in this document. In particular, and without limitation, these intellectual property rights may include one or more of the U.S. patents listed at <http://www.sun.com/patents> and one or more additional patents or pending patent applications in the U.S. and in other countries.

This document and the product to which it pertains are distributed under licenses restricting their use, copying, distribution, and decompilation. No part of the product or of this document may be reproduced in any form by any means without prior written authorization of Sun and its licensors, if any.

Third-party software, including font technology, is copyrighted and licensed from Sun suppliers.

Parts of the product may be derived from Berkeley BSD systems, licensed from the University of California. UNIX is a registered trademark in the U.S. and in other countries, exclusively licensed through X/Open Company, Ltd.

Sun, Sun Microsystems, the Sun logo, AnswerBook2, docs.sun.com, Sun Fire, SunVTS, Sun Fireplane interconnect, and Solaris are trademarks or registered trademarks of Sun Microsystems, Inc. in the U.S. and in other countries.

All SPARC trademarks are used under license and are trademarks or registered trademarks of SPARC International, Inc. in the U.S. and in other countries. Products bearing SPARC trademarks are based upon an architecture developed by Sun Microsystems, Inc.

The OPEN LOOK and Sun™ Graphical User Interface was developed by Sun Microsystems, Inc. for its users and licensees. Sun acknowledges the pioneering efforts of Xerox in researching and developing the concept of visual or graphical user interfaces for the computer industry. Sun holds a non-exclusive license from Xerox to the Xerox Graphical User Interface, which license also covers Sun's licensees who implement OPEN LOOK GUIs and otherwise comply with Sun's written license agreements.

U.S. Government Rights-Commercial use. Government users are subject to the Sun Microsystems, Inc. standard license agreement and applicable provisions of the FAR and its supplements.

DOCUMENTATION IS PROVIDED "AS IS" AND ALL EXPRESS OR IMPLIED CONDITIONS, REPRESENTATIONS AND WARRANTIES, INCLUDING ANY IMPLIED WARRANTY OF MERCHANTABILITY, FITNESS FOR A PARTICULAR PURPOSE OR NON-INFRINGEMENT, ARE DISCLAIMED, EXCEPT TO THE EXTENT THAT SUCH DISCLAIMERS ARE HELD TO BE LEGALLY INVALID.

Copyright 2003 Sun Microsystems, Inc., 4150 Network Circle, Santa Clara, Californie 95054, Etats-Unis. Tous droits réservés.

Sun Microsystems, Inc. a les droits de propriété intellectuels relatants à la technologie incorporée dans le produit qui est décrit dans ce document. En particulier, et sans la limitation, ces droits de propriété intellectuels peuvent inclure un ou plus des brevets américains énumérés à <http://www.sun.com/patents> et un ou les brevets plus supplémentaires ou les applications de brevet en attente dans les Etats-Unis et dans les autres pays.

Ce produit ou document est protégé par un copyright et distribué avec des licences qui en restreignent l'utilisation, la copie, la distribution, et la décompilation. Aucune partie de ce produit ou document ne peut être reproduite sous aucune forme, par quelque moyen que ce soit, sans l'autorisation préalable et écrite de Sun et de ses bailleurs de licence, s'il y en a.

Le logiciel détenu par des tiers, et qui comprend la technologie relative aux polices de caractères, est protégé par un copyright et licencié par des fournisseurs de Sun.

Des parties de ce produit pourront être dérivées des systèmes Berkeley BSD licenciés par l'Université de Californie. UNIX est une marque déposée aux Etats-Unis et dans d'autres pays et licenciée exclusivement par X/Open Company, Ltd.

Sun, Sun Microsystems, le logo Sun, AnswerBook2, docs.sun.com, Sun Fire, SunVTS, Sun Fireplane interconnect, et Solaris sont des marques de fabrique ou des marques déposées de Sun Microsystems, Inc. aux Etats-Unis et dans d'autres pays.

Toutes les marques SPARC sont utilisées sous licence et sont des marques de fabrique ou des marques déposées de SPARC International, Inc. aux Etats-Unis et dans d'autres pays. Les produits portant les marques SPARC sont basés sur une architecture développée par Sun Microsystems, Inc.

L'interface d'utilisation graphique OPEN LOOK et Sun™ a été développée par Sun Microsystems, Inc. pour ses utilisateurs et licenciés. Sun reconnaît les efforts de pionniers de Xerox pour la recherche et le développement du concept des interfaces d'utilisation visuelle ou graphique pour l'industrie de l'informatique. Sun détient une licence non exclusive de Xerox sur l'interface d'utilisation graphique Xerox, cette licence couvrant également les licenciés de Sun qui mettent en place l'interface d'utilisation graphique OPEN LOOK et qui en outre se conforment aux licences écrites de Sun.

LA DOCUMENTATION EST FOURNIE "EN L'ÉTAT" ET TOUTES AUTRES CONDITIONS, DECLARATIONS ET GARANTIES EXPRESSES OU TACITES SONT FORMELLEMENT EXCLUES, DANS LA MESURE AUTORISÉE PAR LA LOI APPLICABLE, Y COMPRIS NOTAMMENT TOUTE GARANTIE IMPLICITE RELATIVE A LA QUALITE MARCHANDE, A L'APTITUDE A UNE UTILISATION PARTICULIERE OU A L'ABSENCE DE CONTREFAÇON.

Contents

Preface xi

- 1. Preparing for Sun Fire 15K/12K Systems Installation** 1-1
 - 1.1 Safety Precautions 1-1
 - 1.2 Site Preparation 1-4
 - 1.3 Connecting the System Controller 1-5
 - 1.4 Connecting the Network Hardware 1-5

- 2. Installing the Sun Fire 15K/12K Systems Hardware** 2-1
 - 2.1 Tools Required 2-1
 - 2.2 Task List for the Host Installation 2-2
 - 2.3 Positioning the System Components 2-3
 - 2.4 Grounding the Cabinet 2-4
 - 2.5 Connecting Power Cables 2-7
 - 2.6 Labeling the I/O Cables 2-8
 - 2.7 Powering On the System 2-9

- 3. Configuring the Preloaded Solaris Domain Software** 3-1

4.	Completing the Sun Fire 15K/12K Systems Installation	4-1
4.1	Running SunVTS on the Host	4-1
4.2	Completing the Installation	4-3
5.	De-Installing the Sun Fire 15K/12K Systems	5-1
5.1	Backing Up Your System	5-1
5.2	Deconfiguring the Domains	5-1
6.	Moving a Sun Fire 15K/12K Systems Cabinet	6-1
6.1	Preparing to Move the Cabinet	6-1
6.2	Preparing the Cabinet	6-2
6.3	Crating the Cabinet	6-3
A.	Compliance Statements	A-1
	Index	Index-1

Figures

- [FIGURE 2-1](#) Sun Fire 15K/12K Systems Grounding 2-4
- [FIGURE 2-2](#) System Board Power and ESD Connections 2-5
- [FIGURE 2-3](#) Ground Cable Attachment Point at System Cabinet 2-6
- [FIGURE 2-4](#) AC Power Cord Installation 2-8
- [FIGURE 2-5](#) Cable Label Example 2-8
- [FIGURE 2-6](#) Circuit Breakers and Power Supplies 2-9
- [FIGURE 4-1](#) I/O Cable Retention 4-3
- [FIGURE 6-1](#) Retracted Leveling Feet 6-2
- [FIGURE 6-2](#) Cabinet Kick Plate Assembly Removal 6-4
- [FIGURE 6-3](#) Installed Ramps on Pallet Deck 6-4
- [FIGURE 6-4](#) Cabinet on Shipping Pallet Deck 6-5
- [FIGURE 6-5](#) Final Packaging and Outside Carton Packaging Assemblies 6-7
- [FIGURE 6-6](#) Cabinet Ready for Shipping 6-8

Tables

TABLE 1-1	Safety Precautions	1-2
TABLE 1-2	Symbols	1-2
TABLE 2-1	Task List	2-2
TABLE 6-1	Access Route Clearance	6-3

Declaration of Conformity

Compliance Model Number: 2080
Product Name: Sun Fire 15K/12K Systems

EMC

European Union

This equipment complies with the following requirements of the EMC Directive 89/336/EEC:

EN55022:1995/CISPR22:1997	Class A
EN55024:1998	4 kV (Direct), 8 kV (Air)
EN61000-4-2	3 V/m
EN61000-4-3	1.0 kV Power Lines, 0.5 kV Signal Lines
EN61000-4-4	1 kV Line-Line, 2 kV Line-Gnd Power Lines
EN61000-4-5	3 V
EN61000-4-6	3 A/m
EN61000-4-8	Pass
EN61000-4-11	Pass
EN61000-3-2:1995	Pass
EN61000-3-3:1995	Pass

Safety

This equipment complies with the following requirements of the Low Voltage Directive 73/23/EEC:

EN60950:1992, 2nd Edition, Amendments 1,2,3,4,11	TÜV Product Service Certificate No. Z1A 01 07 17641 013
IEC 950:1991, 2nd Edition, Amendments 1,2,3,4 Evaluated to all CB Countries	CB Scheme Certificate No. CB 01 07 17641 014

Supplementary Information

This product was tested and complies with all the requirements for the CE Mark.

Dennis P. Symanski
Manager, Compliance Engineering
Sun Microsystems, Inc.
4150 Network Circle
Santa Clara, CA 95054, USA

DATE

Tel: 650-786-3255
Fax: 650-786-3723

Peter Arkless
Quality Manager
Sun Microsystems Scotland, Limited
Springfield, Linlithgow
West Lothian, EH49 7LR
Scotland, United Kingdom

DATE

Tel: 0506-670000
Fax: 0506 760011

Preface

The *Sun Fire 15K/12K Systems Hardware Installation and De-Installation Guide* provides the procedures for installing and configuring the host hardware and software.

This document is for service personnel and customer data center staff, who are involved in the site preparation for and installation of the Sun Fire™ 15K/12K systems.

How This Book Is Organized

Chapter 1 details general safety information and site preparation that must be completed prior to system installation.

Chapter 2 describes the primary steps required for system hardware installation and testing.

Chapter 3 shows the steps required to define multiple domains on the system platform.

Chapter 4 provides information for the verification of proper system setup.

Chapter 5 defines the proper procedures for system shutdown before moving to another location.

Chapter 6 details the steps for moving the system or packaging prior to relocating.

Using UNIX Commands

This document might not contain information on basic UNIX® commands and procedures such as shutting down the system, booting the system, and configuring devices.

See the following for this information:

- Documentation for the Solaris™ operating environment, which is at:
<http://docs.sun.com>
- Other software documentation that you received with your system

Typographic Conventions

TABLE P-1 Typographic Conventions

Typeface	Meaning	Examples
AaBbCc123	The names of commands, files, and directories; on-screen computer output	Edit your <code>.login</code> file. Use <code>ls -a</code> to list all files. % You have mail.
AaBbCc123	What you type, when contrasted with on-screen computer output	% su Password:
<i>AaBbCc123</i>	Book titles, new words or terms, words to be emphasized	Read Chapter 6 in the <i>User's Guide</i> . These are called <i>class</i> options. You <i>must</i> be superuser to do this.
	Command-line variable; replace with a real name or value	To delete a file, type <code>rm filename</code> .

Shell Prompts

TABLE P-2 Shell Prompts

Shell	Prompt
C shell	<i>machine_name%</i>
C shell superuser	<i>machine_name#</i>
Bourne shell and Korn shell	\$
Bourne shell and Korn shell superuser	#

Related Documentation

TABLE P-3 Related Documentation

Application	Title
Service	<i>Sun Fire 15K/12K Systems Read Me First</i>
Service	<i>Sun Fire 15K/12K Systems Getting Started</i>
Service	<i>Sun Fire 15K/12K Systems Unpacking Guide</i>
Service	<i>Sun Fire 15K/12K Systems Site Planning Guide</i>
Service	<i>Sun Fire 15K/12K Systems Hardware Installation and De-Installation Guide</i>
Service	<i>Sun Fire 15K/12K Systems Service Manual</i>
Service	<i>Sun Fire 15K/12K Systems Service Reference I—Nomenclature</i>
Service	<i>Sun Fire 15K/12K Systems Service Reference II—Component Numbering</i>
Service	<i>Sun Fire 15K/12K Systems Carrier Plate Configurations</i>

Accessing Sun Documentation

You can view, print, or purchase a broad selection of Sun documentation, including localized versions, at:

<http://www.sun.com/documentation>

Contacting Sun Technical Support

If you have technical questions about this product that are not answered in this document, go to:

<http://www.sun.com/service/contacting>

Sun Welcomes Your Comments

Sun is interested in improving its documentation and welcomes your comments and suggestions. You can submit your comments by going to:

<http://www.sun.com/hwdocs/feedback>

Please include the title and part number of your document with your feedback:

Sun Fire 15K/12K Systems Hardware Installation and De-Installation Guide, part number 806-3511-12

United States Export Control Laws Notice

Products covered by and information contained in this installation and de-installation guide are controlled by U.S. Export Control laws and might be subject to the export or import laws in other countries. Nuclear, missile, chemical biological weapons, or nuclear maritime end uses or end users, whether direct or indirect, are strictly prohibited. Export or re-export to countries subject to U.S. embargo or to entities identified on U.S. export exclusion lists, including but not limited to the denied persons and specially designated nationals lists, is strictly prohibited. Use of any spare or replacement CPUs is limited to repair or one-for-one replacement of CPUs in products exported in compliance with U.S. export laws. Use of CPUs as product upgrades unless authorized by the U.S. Government is strictly prohibited.

Preparing for Sun Fire 15K/12K Systems Installation

1.1 Safety Precautions

For your protection, observe the following safety precautions when setting up your equipment:

- Follow all cautions, warnings, and instructions marked on the equipment.
- Ensure that the voltage and frequency rating of the power source you use matches the electrical rating label on the equipment.
- Use only properly grounded power outlets.
- Never push objects of any kind through openings in the equipment, because they might touch dangerous voltage points or short out components that can result in fire or electric shock.
- Use only qualified personnel to service the equipment.

To protect both yourself and the equipment, observe the precautions listed in [TABLE 1-1](#):

TABLE 1-1 Safety Precautions

Item	Problem	Precaution
AC/DC power	Electric shock	Verify that all AC and DC power has been properly neutralized prior to servicing. Keep AC ground connected during servicing to provide a cabinet ground for ESD protection.
ESD kit	Static	An approved ESD mat provides protection from static damage when used with a wrist strap or foot strap. Use the Sun Microsystems™ provided ESD kit when handling Sun Fire components.
Wrist strap or foot strap	Static	Wear a conductive wrist strap or foot strap when handling printed circuit boards.
Cover panels	System damage and overheating	Attach all cabinet cover panels after performing any service work on the system.
Filler panels	System damage and overheating	Install card cage filler panels in all unused card cage slots. Open slots severely reduce the cooling capability of the system.
PCI slot covers	System damage and overheating	Install PCI slot covers in all unused system board PCI slots. Openings on the backs of system boards reduce the cooling capability of the system.

Several symbols are used in this guide to mark sections which should receive special attention. Review [TABLE 1-2](#) for these symbols and their definitions.

TABLE 1-2 Symbols







	Caution	This equipment contains lethal voltage. Accidental contact with the centerplane, card cage, and drive areas can result in serious injury or death.
	Caution	Risk of personal injury and equipment damage. To reduce the risk, follow the instructions.
	AC	A terminal to which alternating current or voltage can be applied.

TABLE 1-2 Symbols (Continued)

	Protective earth	Protective earth conductor.
	Chassis	Frame or chassis terminal.
	Fuse replacement marking	For continued protection against risk of fire and electric shock, replace ONLY with the same type and rating of fuse.



Caution – Improper handling by unqualified personnel can cause serious damage to this equipment. Unqualified personnel who tamper with this equipment can be held liable for any resulting damage to the equipment.

All procedures contained in this document must be performed by *qualified service-trained maintenance providers*.



Caution – Before you begin, carefully read each of the procedures in this manual. If you have not performed similar operations on comparable equipment, *do not attempt* to perform these procedures.

1.2 Site Preparation

Note – Site preparation is detailed in the *Sun Fire 15K/12K Systems Site Planning Guide*.

It is the customer's responsibility to prepare the site. Sun Microsystems Customer Service or an authorized distributor can assist with the site-planning process and will install the equipment upon notification of delivery from the customer.

Prior to the installation of the system, verify the following items:

1. The area for the system has been thoroughly cleaned and vacuumed in preparation for installation.
2. If the customer has noted problems or peculiarities at the site that require special equipment, it is the responsibility of the customer to obtain such equipment.
3. The installation checklist and report have been located and are available.
4. The shipper and Sun Microsystems have been notified of all missing or damaged items.
5. Installation of the necessary electrical equipment is complete, and sufficient power is provided, as stated in the *Sun Fire 15K/12K Systems Site Planning Guide*.
6. Adequate air conditioning is provided as stated in the *Sun Fire 15K/12K Systems Site Planning Guide*.
7. The air conditioning system has been operational and running for 48 hours to bring the room to the appropriate temperature as stated in the *Sun Fire 15K/12K Systems Site Planning Guide*.
8. Access to the data center network is available as described in the *Sun Fire 15K/12K Systems Site Planning Guide*.
9. The system is unpacked and moved to the installation area as stated in the *Sun Fire 15K/12K Systems Site Planning Guide* and the *Sun Fire 15K/12K Systems Unpacking Guide*.

The *Sun Fire 15K/12K Systems Site Planning Guide* provides the necessary information to complete these tasks.

1.3 Connecting the System Controller

The Sun Fire 15K/12K systems have a system controller (System Control board and system control peripheral) that supports administrative control and monitoring of the platform. Two system controllers are included in each of the Sun Fire 15K/12K systems frame. One system controller acts as the primary controller. A second system controller is available to automatically assume administrative control should the primary system controller fail. System Management Services (SMS) software runs on the system controller and provides the control and monitoring.

The system controllers receive their power from the Sun Fire 15K/12K systems power supplies. Connection to the data center power source must be completed in order to power on the system controller and start platform configuration. See [Chapter 2](#) of this document and [Chapter 3](#) of the *Sun Fire 15K/12K Systems Site Planning Guide* for details about connecting the platform to the data center power source.

Each system controller requires a console connection. This connection is used for initial configuration, including provisions for the IP addresses used on the customer data center network. An eight-pin DIN-type connector on the front of the System Control (SC) processor board can provide the console connection. This cable terminates into a standard DB-25 connector. This cable may be connected to any tip-compatible terminal (such as VT150) or terminal concentrator. Refer to the *Sun Fire 15K/12K Systems Service Manual* for pin-out termination specifications of the SC-CPU cable.

The console connection, or a Telnet connection, may be used to interact with the command line versions of the SMS software. A display device is required for GUI administration. Any X-capable device may be used to display the output of SMS GUI software. Programs will run on the SC with the output displayed on the administrator's terminal.

1.4 Connecting the Network Hardware

The two system controllers and each dynamic system domain require a connection to the customer data center network. These connections must be made prior to configuring the hardware. Review [Chapter 4](#), Network Planning, of the *Sun Fire 15K/12K Systems Site Planning Guide* for options available in making connections to the data center network.

Installing the Sun Fire 15K/12K Systems Hardware

2.1 Tools Required

Note – The following list represents the minimum of tools and test equipment that you need to install the processor cabinet:

- Screwdriver, common (flat-bladed), 1/8-inch, 3/16-inch
- Screwdriver, No. 2 Phillips
- Digital voltmeter (DVM)
- 9/16 inch open-end wrench, or equivalent
- Nut driver (1/2 inch)

2.2 Task List for the Host Installation

TABLE 2-1 Task List

Task	Reference
Position the system components.	Section 2.3, "Positioning the System Components" on page 2-3
Cable the system.	<ul style="list-style-type: none">• Section 2.4, "Grounding the Cabinet" on page 2-4• Section 2.5, "Connecting Power Cables" on page 2-7• Section 2.6, "Labeling the I/O Cables" on page 2-8
Apply power to the AC components.	Section 2.7 "Powering On the System" on page 9
Configure the preloaded domain.	Chapter 3
Finalize the system installation.	Chapter 4
De-install the system.	Chapter 5
Move the system.	Chapter 6

2.3 Positioning the System Components



Caution – Do not make mechanical or electrical modifications to the processor or I/O cabinets. Sun Microsystems is not responsible for the regulatory compliance if the cabinets are modified.

1. **If a raised floor is installed, locate the cable cutouts.**
2. **Verify proper air flow floor panels are used and move the cabinets to facilitate cable installation.**
Refer to [Section 2.2, “Basic Cooling Requirements”](#) on page 2-2 of the *Sun Fire 15K/12K Systems Site Planning Guide*.
3. **Place the processor and I/O cabinets in the designated area.**
Refer to [Section 2.3, “Computer Room Layout”](#) on page 2-6 of the *Sun Fire 15K/12K Systems Site Planning Guide*. [FIGURE 2-2](#) provides various floor layout samples.
4. **Place the processor cabinet in the customer-supplied space and confirm the doors can open for servicing.**
5. **Verify all power supply breakers (AC0, AC1) are in the off position.**

2.4 Grounding the Cabinet

The Sun Fire 15K/12K systems achieve earth ground through the power cords. For this reason, a grounding cable is not provided with the system. The power cords have three prongs: two for current and one for ground. At the AC input module, the ground prong and system chassis are connected. Final chassis ground is achieved when the power cord is connected to a receptacle, where the ground prong contacts the power receptacle. For successful grounding, the customer must provide properly grounded power receptacles so the power distribution unit (PDU) ground is earth ground. See [FIGURE 2-1](#) for a definition of the grounding system and [FIGURE 2-2](#) for system board power and electrostatic device (ESD) connections.

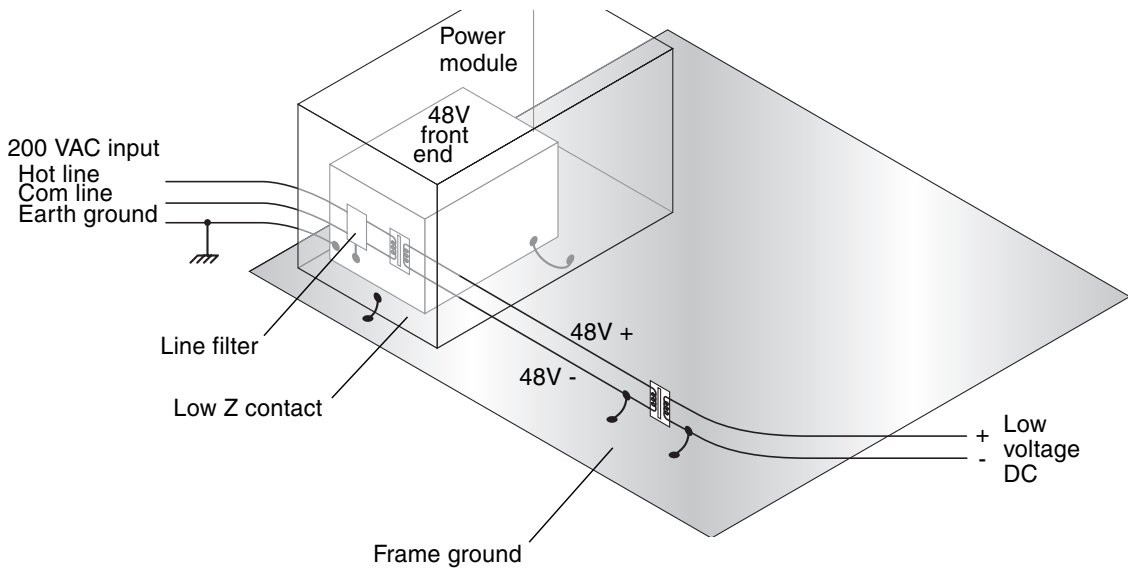

FIGURE 2-1 Sun Fire 15K/12K Systems Grounding

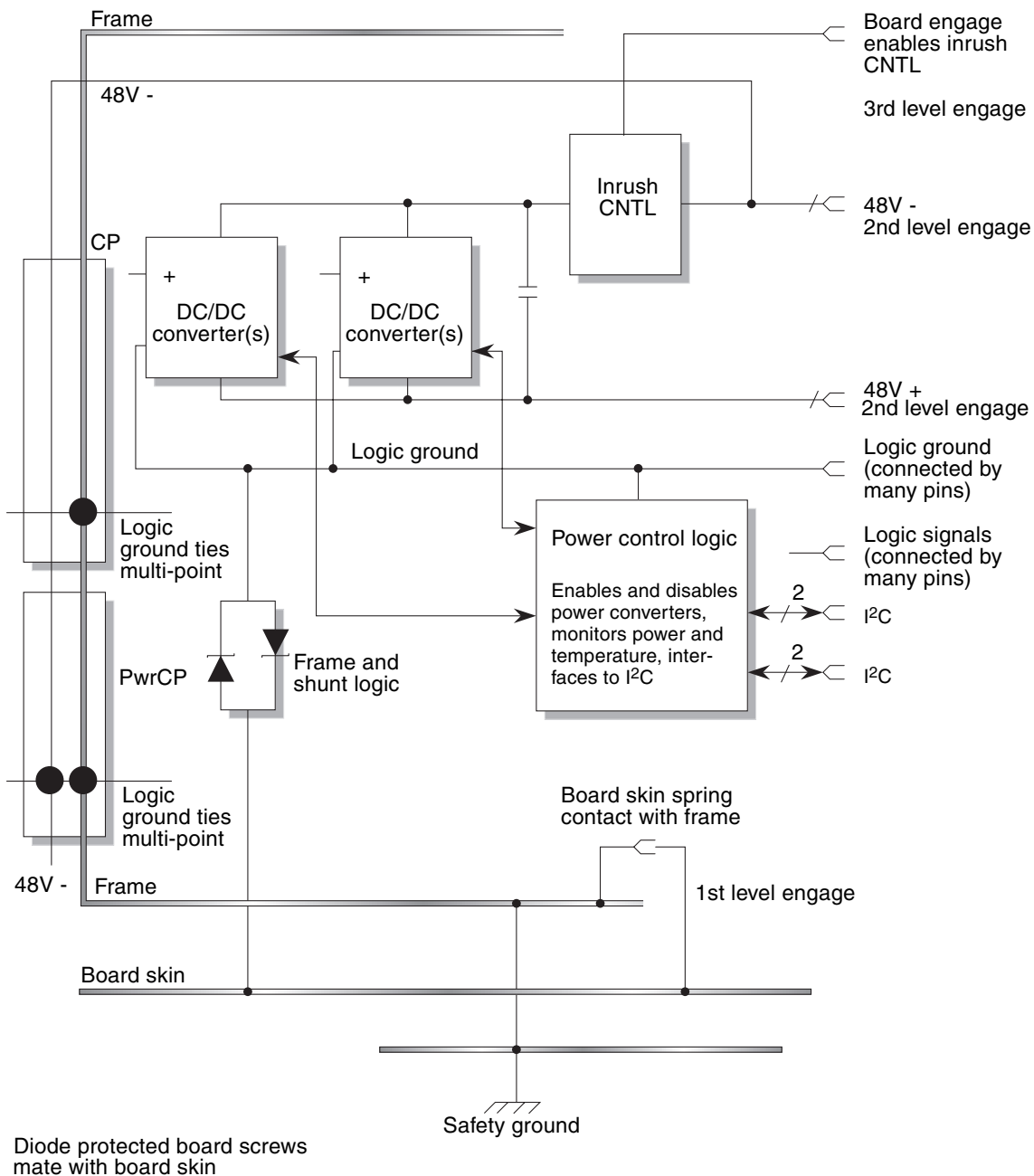

FIGURE 2-2 System Board Power and ESD Connections

A ground cable may be affixed to the system. While not required, the additional ground point allows leakage current to dissipate more efficiently. It is important to note that power cords are grounded through the receptacle and the ground cable must reference a common earth ground. Otherwise, a difference in ground potential can be introduced.



Caution – If the customer is unsure of the facility PDU receptacle grounding, *do not install* a ground cable until a proper PDU receptacle grounding has been confirmed. If a difference in ground potential is apparent, *you must take corrective action*.

Use the following procedures to properly ground the Sun Fire 15K/12K systems:

1. **Ensure the customer site has properly grounded PDUs in the data center. The PDU must be earth ground.**
2. **Ensure that all grounding points (raised floors and power receptacles) reference PDU ground.**

Note – If the customer chooses to ground the system, the customer must procure the grounding cable. A grounding cable is not shipped with the system.



Caution – During manufacturing, the ground cable attaching area might be a painted surface. Ensure metal-to-metal solid contact is made for this installation.

3. **Attach the ground cable to the system, behind the kick plate, at the bottom of the frame base as shown in [FIGURE 2-3](#).**

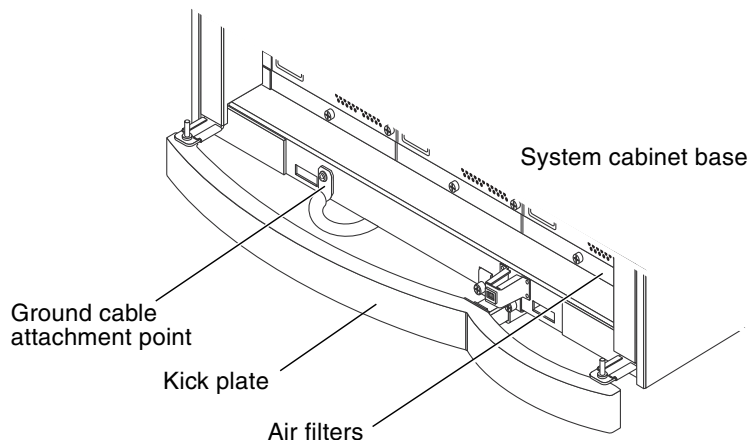

FIGURE 2-3 Ground Cable Attachment Point at System Cabinet

2.5 Connecting Power Cables



Caution – Do not make mechanical or electrical modifications to the processor or I/O cabinets. Sun Microsystems is not responsible for the regulatory compliance if the cabinets are modified.

The system requires an electrical circuit that is grounded to earth. The American standards group, Underwriters Laboratories, Inc., specifies:

An insulated earth-ground conductor that is identical in size, insulation material, and thickness to the earthed and unearthed branch-circuit supply conductors, except that it is green with or without one or more yellow stripes, is to be installed as part of the branch circuit that supplies the unit or system. The earthing conductor described is to be connected to earth at the service equipment or, if supplied by a separately derived system, at the supply transformer or motor-generator set.

The attachment-plug receptacles in the vicinity of the unit or system are all to be of an earthing type, and the earthing conductors serving these receptacles are to be connected to earth at the service equipment.



Caution – The AC power connections provide a ground path that will protect the components (boards and drives) in the cabinet from static electricity damage.

Complete the following connections with the provided cables:

1. **Verify ALL of the power supply breakers (AC0, AC1) are in the off position prior to connecting any power cords.**
2. **Verify with a digital voltmeter (DVM) that the incoming AC voltage is correct for the customer site.**

Refer to the *Sun Fire 15K/12K Systems Site Planning Guide* for further information.

3. **Connect the AC power cords into their appropriate AC connectors on the front panel of the power supply.**

See [FIGURE 2-4](#) to determine the proper part number and orientation for connection. The strain relief for the AC0 power cable housing is positioned downward when connected. The strain relief for the AC1 power cable housings is positioned upward when connected. Power source A cord will normally connect into AC0. Power source B cord will normally connect into AC1.

4. **Secure all of the cables to improve overall appearance and prevent damage.**

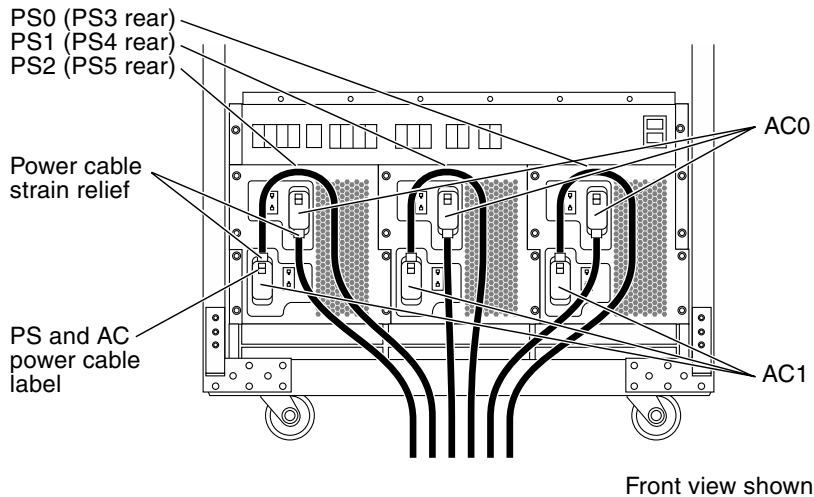

FIGURE 2-4 AC Power Cord Installation

2.6 Labeling the I/O Cables

Once you have verified the site according to the *Sun Fire 15K/12K Systems Site Planning Guide*, and the system is in place (as detailed in [Section 2.3, "Positioning the System Components" on page 2-3](#)), then the system cabling can be installed and connected, ([FIGURE 2-5](#)). A set of labels is delivered with the system to facilitate labelling new and replaced parts. The set consists of multiple sheets of labels that are used to identify point-to-point connections. The label can be used for all new cables as well as for relabeling requirements for any cables that might need to be reconfigured.

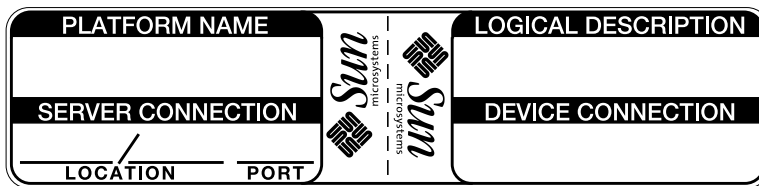

FIGURE 2-5 Cable Label Example

2.7 Powering On the System

1. Power on the customer-supplied AC circuit breakers.
2. Ensure all DC circuit breakers at the front and rear power modules are in the on position (FIGURE 2-6).

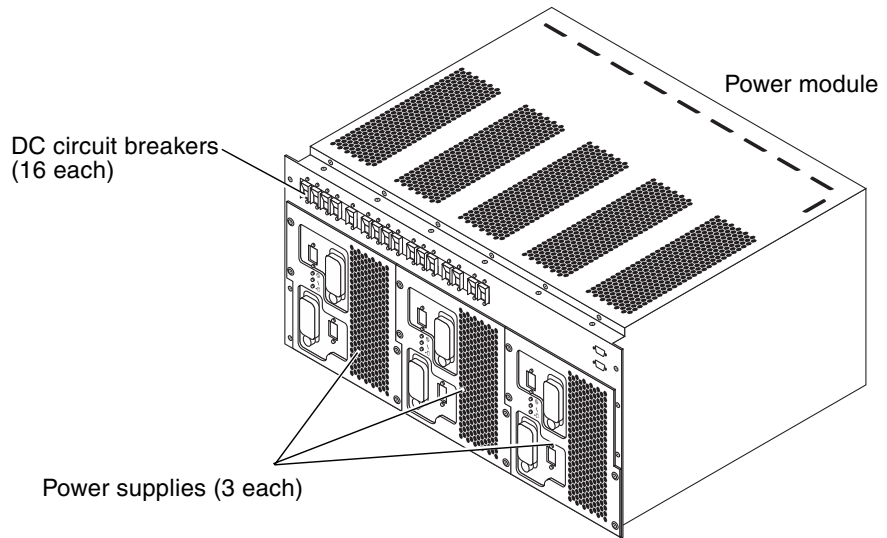

FIGURE 2-6 Circuit Breakers and Power Supplies

3. Sequentially activate all of the front panel circuit breakers (two circuit breakers per power supply, three power supplies per system, front and rear) on the power supply modules to apply power to the system.

Configuring the Preloaded Solaris Domain Software

The procedures in this chapter are used to install customer network parameters on the first domain of the Sun Fire 15K/12K systems. These procedures assume that you have opened both an SC command line window and a `domain console(1M)` window at your terminal display.

This configuration is performed on the preloaded domain when the host arrives at your site from the factory. Do not perform this procedure if you are recovering from a crash or installing a new domain.

1. Log in to the Main SC as user `sms-svc`.

The default password is `xxxxxxx`.

2. Create a domain by typing:

```
sms-svc% addboard -d domain_id domain_tag -c assign  
board_type,board_id
```

where *domain_id* = domain letter ID. Valid *domain_ids* are 'A'...'R' and case insensitive. *domain_id* 'A' should be used for the factory configured domain.

domain_tag is a name assigned to a domain using `addtag(1M)`.

where *board_type* = board letter ID. List of boards separated by a space. Board type is optional. *Board_ID* is not optional and corresponds to `expander.slot` pairs. Valid pairs are <0-17>.<0-1>. Multiple board identifier arguments are permitted.

The following *board_type*, *board_id* forms are acceptable:

```
cpu, (0..17) [.0]  
dcpu, (0..17) [.1] (MaxCPU)  
iobd, (0..17) [.1] (hsPCI I/O)
```

Example:

```
addboard -d A -c assign cpu,0.0 iobd,0.1 cpu,1.0 cpu,2.0
```

3. Bring up the domain by typing:

```
sms-svc% setkeyswitch -d A on
```

4. After the setkeyswitch process is complete, type:

```
sms-svc% console -d A
```

After a few minutes, the ok> prompt is displayed.

5. Boot the domain by typing:

```
ok> boot
```

When the first time the domain OS is booted, the administrator is asked to define host specific information. This includes the hostname, locale, and IP address information. See the Solaris installation manuals for this information.

Completing the Sun Fire 15K/12K Systems Installation

Once the system has been booted and properly configured on the network, run diagnostics.

4.1 Running SunVTS on the Host

The host must first be booted and the local and network variables configured before you run SunVTS™ software.

SunVTS tests the overall functionality of all parts (processor and I/O) of the system. While an overnight SunVTS run is considered ideal, anywhere between 4 to 24 hours is appropriate as a system test.

1. **Log in to an X-capable display station, ensure that your domain can open a connection, and type:**

```
% xhost +
```

2. Start SunVTS by logging in to the domain as `superuser`:

```
# csh
# setenv DISPLAY sc_hostname:0.0
# setenv LD_LIBRARY_PATH /usr/openwin/lib
# setenv OPENWINHOME /usr/openwin
# /opt/SUNWvts/bin/sunvts -l
```

If SunVTS fails to initialize, you may need to install SunVTS. Refer to the SunVTS AnswerBook documentation for more information.

3. Display the SunVTS window and check the devices shown in the control panel against the devices you know to be physically present in the system.

Starting SunVTS often serves as a quick check for most hardware devices. If you have just installed a device and reconfigured your system accordingly, the SunVTS test for that device can confirm proper installation.

Refer to the “control panel” section of the SunVTS documentation if there is a discrepancy.

If SunVTS fails to display a device that you know is physically present in the system, recheck your installation carefully.

4. Click the Start button.

Or, if you have enabled the Auto Start option from the Set SunVTS Options menu and saved an options file, you can start SunVTS by typing:

```
# /opt/SUNWvts/bin/sunvts -l -o options_filename
```

5. Monitor the status of SunVTS.

Verify that the system is running and that no test failures are occurring.

6. Repeat [Step 2](#) through [Step 5](#) for each domain to be tested.

4.2 Completing the Installation

1. Install and configure all purchased software packages.
2. Obtain a hardware status of the domain by typing:

```
% /usr/platform/sun4u1/sbin/prtdiag -v
```

Repeat this step for each domain.

3. Confirm all cables are firmly seated and the attachment hardware is tight.
4. Position all cables in the I/O cable retention bracket on the air plenum and secure with Velcro cable ties shown in [FIGURE 4-1](#).

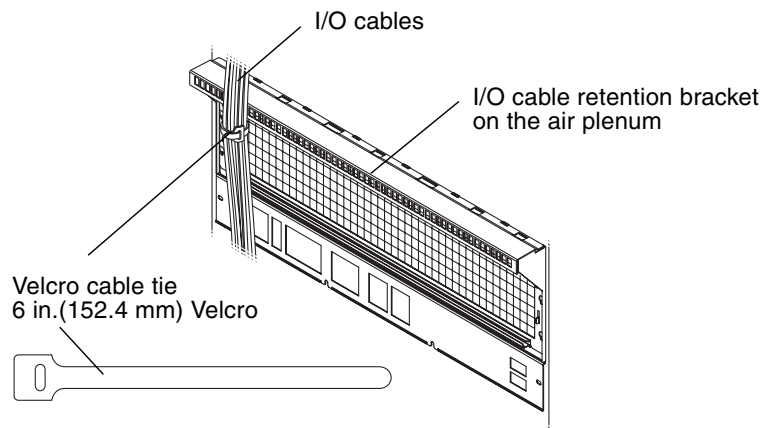

FIGURE 4-1 I/O Cable Retention

5. Close all of the access doors.
6. Verify the side panels are positioned correctly on the cabinet.
7. Verify the cabinets are positioned according to the site plan.
8. Lower the leveling feet on all four corners of the system cabinet until the leveling feet touch the floor.
9. Adjust the leveling feet down one additional quarter turn.

10. Visually inspect where the two access doors meet. Adjust the leveling feet until the access doors are even and straight.

Repeat this step for the other side of the system cabinet.



Caution – Do not allow the leveling feet to support the entire weight of the system cabinet. Confirm this by visually inspecting the casters to verify that they are in contact with the floor.

11. Following the installation of the Sun Fire 15K/12K systems, complete and return the Installation Report that was shipped with the system cabinet.

The installation is now complete. In the event of a failure, refer to the following documents:

- *Sun Fire 15K/12K Systems Overview Manual*
- *Sun Fire 15K/12K Systems Service Manual*

De-Installing the Sun Fire 15K/12K Systems

This chapter describes the procedures to properly shut down the system in preparation for moving. See [Chapter 6](#) of this document for details.

5.1 Backing Up Your System

- Have the system administrator verify that all domains and the SCs have been properly backed up.

5.2 Deconfiguring the Domains

1. **Deconfigure the domains.**

Refer to the *Sun Fire 15K/12K Systems Management Services (SMS) 1.1 Administrator Guide*.

2. **Save the SMS configuration files.**

3. **Deconfigure the SC.**

Refer to the *Sun Fire 15K/12K Systems Management Services (SMS) 1.2 Administrator Guide*.

4. **Power down the system by referring to the following sections within the *Sun Fire 15K/12K Systems Service Manual*:**

- [Section 11.2.2, “Powering Off a Centerplane Support Board”](#) on page 11-4
- [Section 6.1.2.2, “Powering Off a System Control \(SC\) Board”](#) on page 6-4

- Section 7.2.2, “Powering Off a System Control (SC) Peripheral Board” on page 7-5
- Section 12.2.2, “Powering Off an Expander Board” on page 12-4
- Section 8.2.2, “Powering Off a CPU (Slot 0) Board” on page 8-4
- Section 9.1.2.2, “Powering Off an hsPCI (Slot 1) Assembly” on page 9-4
- Section 9.4.2.2, “Powering Off a MaxCPU (Slot 1) Board” on page 9-13
- Section 3.2.2.2, “Powering Off a 4 kW Dual AC–DC Power Supply” on page 3-11
- Section 4.2.2, “Powering Off a Fan Tray” on page 4-4
- Section 14.1, “Powering Off for Fan Backplane Removal” on page 14-2
- Section 13.3, “Powering Off the System for Sun Fireplane Interconnect Replacement” on page 13-4
- Section 15.1, “Powering Off the System for Power Centerplane Replacement” on page 15-2
- Section 16.2.1, “Powering Off the System for Cable Replacement” on page 16-8



Note – The following statement appears in the power module, fan backplane, Sun Fireplane interconnect, power centerplane, and cable replacement procedures in the *Sun Fire 15K/12K Systems Service Manual*: All DC circuit breakers are to remain in the on position at all times.

Disregard this statement when deconfiguring the domain in preparation for system relocation.

5. **Power off all DC circuit breakers on the front and rear of the system cabinet.**
6. **Power off all AC0 and AC1 circuit breakers at the front and rear of the system.**
7. **Power off the customer-supplied AC circuit breakers.**
8. **Disconnect all power cables from the power supplies at AC0 and AC1 at the front and rear of the system.**

Moving a Sun Fire 15K/12K Systems Cabinet

6.1 Preparing to Move the Cabinet

1. **Because shipping foam compresses in transit, Sun Fire 15K/12K systems cabinets cannot be shipped with a previously used shipping pallet. Obtain a new shipping package that contains a new pallet along with some of the following items:**
 - Pallet
 - Pallet-rack fasteners
 - Finished packaging (internal FrameManager or TopCap, outer wraps)
 - Closing materials (labeling, bags)

Customers may obtain a shipping package by submitting the *Replacement Packaging Request Form* at <http://206.170.159.131/rplpkg.html>. For Sun service personnel, go to <http://uscq.ebay/Other/packaging.html>.

2. **Determine if the customer has strapping material and tools which are usually available from the customer's shipping department.**
3. **Obtain the required tools.**
 - 9/16 inch open-end wrench, or equivalent, is required.

6.2 Preparing the Cabinet

1. **Open the front and rear doors to inspect the cabinet components.**

Confirm all of the components are fully seated and all of the hardware is tightened.

2. **Prepare the cabinet prior to moving.**



Caution – Damage can occur to the four cabinet doors during crating. They must be removed from the cabinet before the unit is pushed onto the pallet deck. Maneuver the cabinet using the edges of the cabinet frame. *Do not use the internal system board handles to move the cabinet.*

- a. **Remove the front and rear doors of the cabinet by pushing down on the top spring-loaded hinge pins and then lift the doors upward to remove from the pin on the bottom hinge bracket of the cabinet.**
 - b. **Set the four doors aside until the cabinet has been secured in place on the shipping pallet deck.**
3. **Locate and install the system handle bars to the front and rear of the system cabinet. Use a Phillips No. 2 screwdriver to secure each handle bar with the four captive screws.**

These two handle bars were removed and retained when the system was installed.
 4. **Raise the leveling feet and ensure that they are fully retracted into the cabinet frame (FIGURE 6-1).**

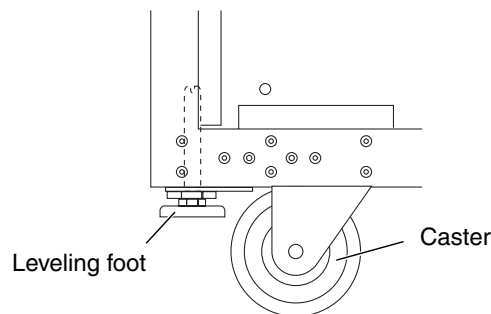

FIGURE 6-1 Retracted Leveling Feet

5. **Inspect the cabinet for any loose hardware or other debris.**
6. **Ensure that all interface cables have been removed from the cabinet.**

7. Move the system to the appropriate shipping area for crating.

The entire access route to your computer room should be free of raised patterns that can cause vibration and must meet the following clearance requirements:

TABLE 6-1 Access Route Clearance

	With Styling Panel	Without Styling Panel
Minimum door height	80.0 in. (2032 mm)	80.0 in. (2032 mm)
Minimum hallway and door width	36.0 in. (915 mm)	36.0 in. (915 mm)
Maximum incline	10°	10°

6.3 Crating the Cabinet

Note – Access to all sides of the cabinet is needed with a minimum of 18 feet (5.49 m) to move the cabinet to the pallet ramps.

1. Prepare the pallet deck for the cabinet roll-up.
 - a. Position the shipping pallet on a flat level surface and orient with a minimum of 18 feet (5.49 m) access space for the cabinet and the ramps.
 - b. Remove the ramps from the boxes in the shipping package.
 - c. Align the tines of the ramps with the corresponding holes on the pallet deck. Verify the ramps are firmly in position by pressing or standing on the back side of the tines.
 - d. Place one of the two supplied pallet chocks at the end of the pallet deck not being used for loading the cabinet.



Caution – The kick plate mounting bracket assembly must be removed from the loading side only prior to pushing the cabinet up the 5 degree loading ramps. The cabinet cannot be moved at an angle of more than 10 degrees maximum.

2. Prepare the cabinet for roll-up onto the shipping pallet deck.
 - a. Remove the kick plate assembly from both ends of the cabinet before loading, (FIGURE 6-2). Use a pull-turn motion to release the spring-loaded captive locking pin, and pull the kick plate and mounting tube outward from the mounting bracket and set aside until the cabinet has been secured in place on the shipping pallet deck.

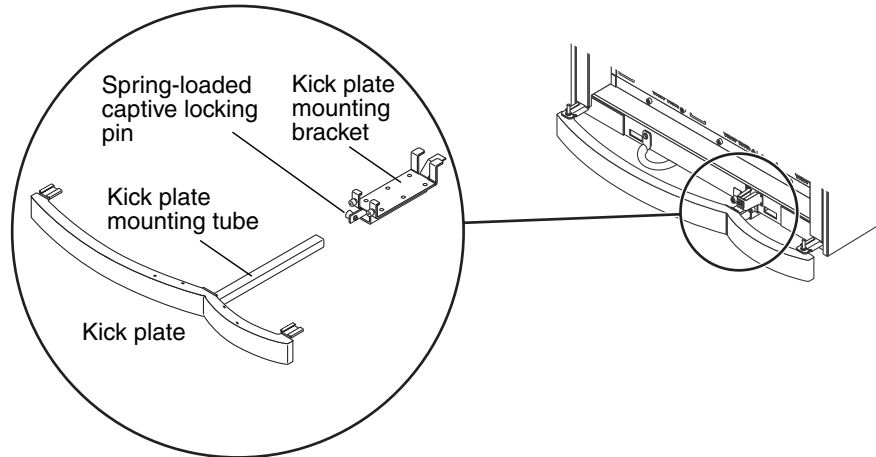

FIGURE 6-2 Cabinet Kick Plate Assembly Removal

- b. Align the cabinet wheels at the leading edge of the two ramps (FIGURE 6-3).

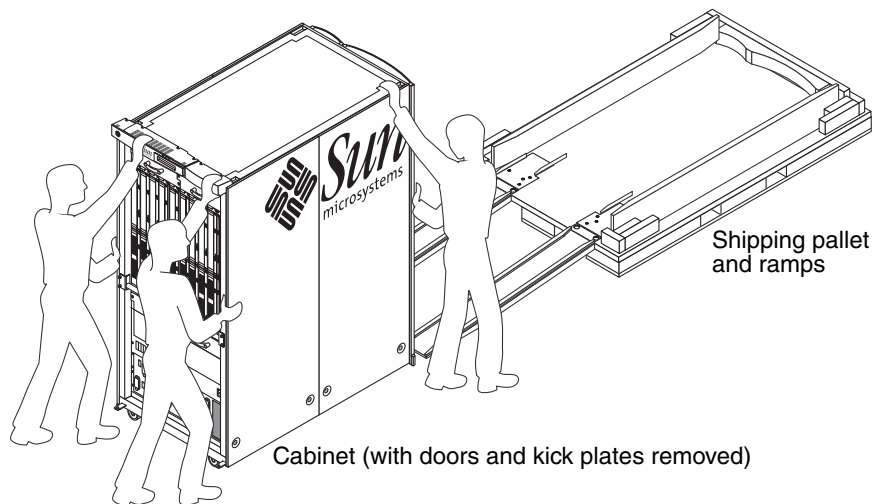

FIGURE 6-3 Installed Ramps on Pallet Deck

Note – The shipping pallet contains holes used to anchor the cabinet onto the pallet deck with zinc-plated shipping brackets and bolts before shipping.

c. Push the cabinet up the ramps and onto the shipping pallet deck.



Caution – One or two persons should push while two others guide the cabinet into the designated shipping position.

d. Locate two zinc-plated toe-clamp shipping brackets and four bolts (FIGURE 6-4).

e. Mount one end of the cabinet to the shipping pallet by inserting each tow clamp of the bracket into the square hole of the frame at the base of the cabinet.

f. Using the 9/16 inch open-end wrench, secure the four bolts to the crate.

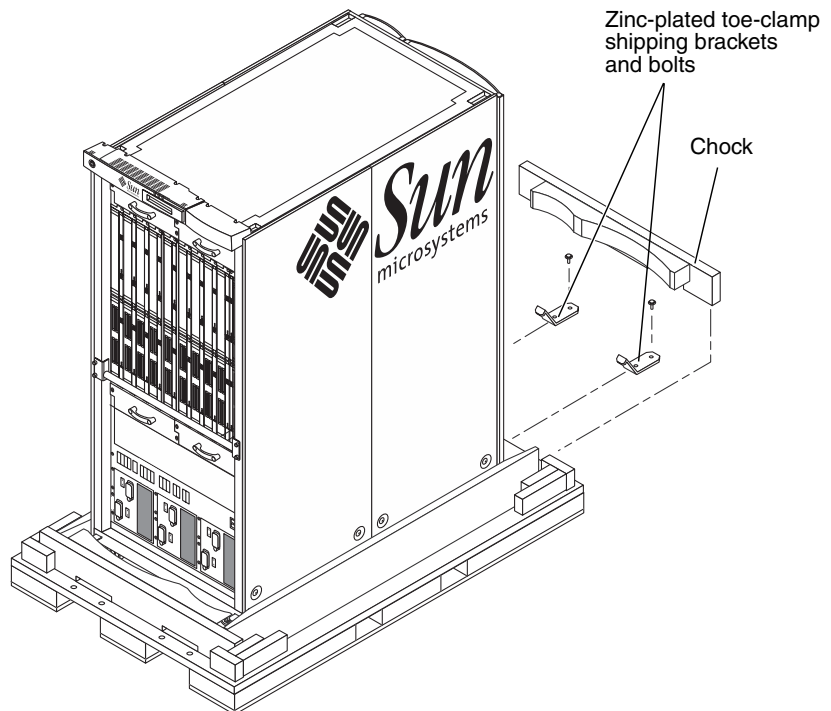

FIGURE 6-4 Cabinet on Shipping Pallet Deck

g. Use the two remaining tow clamp shipping brackets and four remaining bolts to mount the other end of the cabinet to the shipping pallet.

4. Assembly outside carton (FIGURE 6-5).

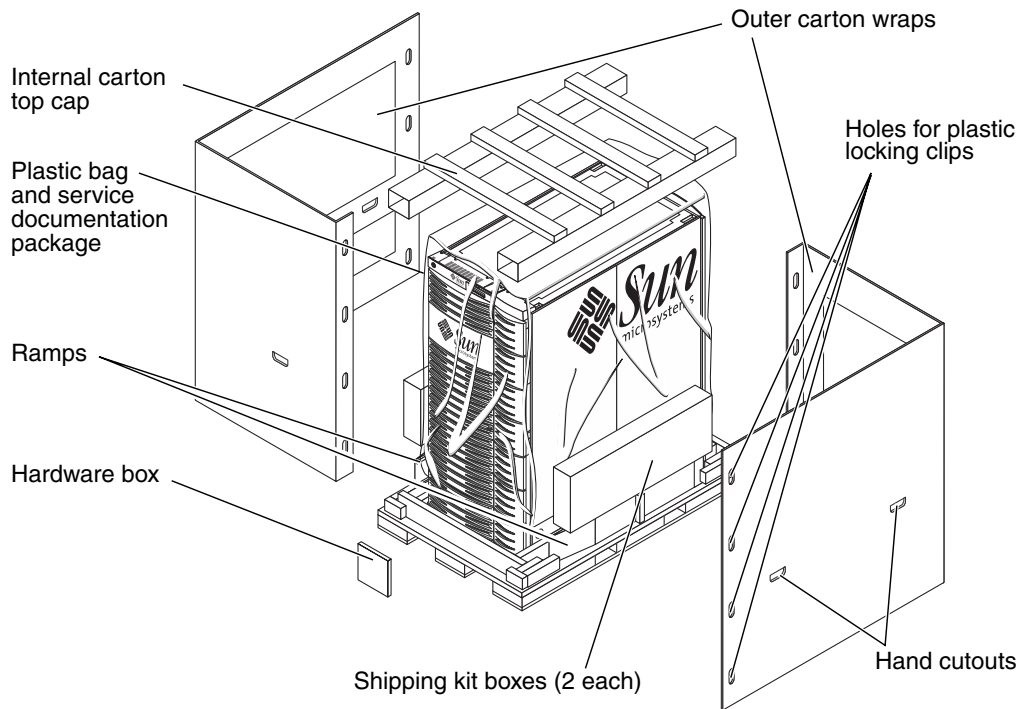

FIGURE 6-5 Final Packaging and Outside Carton Packaging Assemblies

- a. Using the hand cutouts, place each of the two outer carton wraps onto the shipping pallet deck, aligning the holes for the plastic locking clips (four per side).
- b. Install the eight plastic locking clips (four per side) into the side edges of the outer carton wraps.
- c. Place the carton top cap on top of the cabinet and over the edges of the outer carton wraps.
- d. Secure with strapping material and fiberboard edge protectors.
Ensure the banding material is tight and properly fitted with the edge protectors (FIGURE 6-6).

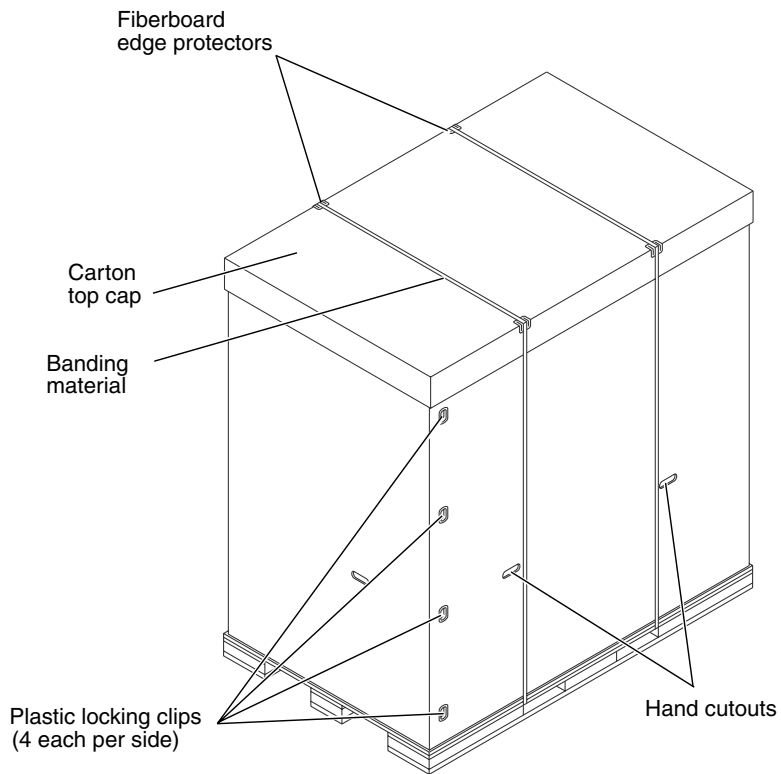

FIGURE 6-6 Cabinet Ready for Shipping

- e. Apply the **TIP-N-TELL** device found in the shipping package to the upper half of the carton side.

Compliance Statements

Regulatory Compliance Statements

Your Sun product is marked to indicate its compliance class:

- Federal Communications Commission (FCC) — USA
- Industry Canada Equipment Standard for Digital Equipment (ICES-003) - Canada
- Voluntary Control Council for Interference (VCCI) — Japan
- Bureau of Standards Metrology and Inspection (BSMI) — Taiwan

Please read the appropriate section that corresponds to the marking on your Sun product before attempting to install the product.

FCC Class A Notice

This device complies with Part 15 of the FCC Rules. Operation is subject to the following two conditions:

1. This device may not cause harmful interference.
2. This device must accept any interference received, including interference that may cause undesired operation.

Note: This equipment has been tested and found to comply with the limits for a Class A digital device, pursuant to Part 15 of the FCC Rules. These limits are designed to provide reasonable protection against harmful interference when the equipment is operated in a commercial environment. This equipment generates, uses, and can radiate radio frequency energy, and if it is not installed and used in accordance with the instruction manual, it may cause harmful interference to radio communications. Operation of this equipment in a residential area is likely to cause harmful interference, in which case the user will be required to correct the interference at his own expense.

Shielded Cables: Connections between the workstation and peripherals must be made using shielded cables to comply with FCC radio frequency emission limits. Networking connections can be made using unshielded twisted-pair (UTP) cables.

Modifications: Any modifications made to this device that are not approved by Sun Microsystems, Inc. may void the authority granted to the user by the FCC to operate this equipment.

ICES-003 Class A Notice - Avis NMB-003, Classe A

This Class A digital apparatus complies with Canadian ICES-003.

Cet appareil numérique de la classe A est conforme à la norme NMB-003 du Canada.

VCCI 基準について

クラス A VCCI 基準について

クラス A VCCI の表示があるワークステーションおよびオプション製品は、クラス A 情報技術装置です。これらの製品には、下記の項目が該当します。

この装置は、情報処理装置等電波障害自主規制協議会 (VCCI) の基準に基づくクラス A 情報技術装置です。この装置を家庭環境で使用すると電波妨害を引き起こすことがあります。この場合には使用者が適切な対策を講ずるよう要求されることがあります。

BSMI Class A Notice

The following statement is applicable to products shipped to Taiwan and marked as Class A on the product compliance label:

警告使用者：
這是甲類的資訊產品，在居住的環境中使用時，可能會造成射頻干擾，在這種情況下，使用者會被要求採取某些適當的對策。

Safety Agency Compliance Statements

Read this section before beginning any procedure. The following text provides safety precautions to follow when installing a Sun Microsystems product:

Safety Precautions

For your protection, observe the following safety precautions when setting up your equipment:

- Follow all cautions and instructions marked on the equipment.
- Ensure that the voltage and frequency of your power source match the voltage and frequency inscribed on the equipment's electrical rating label.
- Never push objects of any kind through openings in the equipment. Dangerous voltages may be present. Conductive foreign objects could produce a short circuit that could cause fire, electric shock, or damage to your equipment.

Symbols

The following symbols may appear in this book:



Caution – There is risk of personal injury and equipment damage. Follow the instructions.



Caution – Hot surface. Avoid contact. Surfaces are hot and may cause personal injury if touched.



Caution – Hazardous voltages are present. To reduce the risk of electric shock and danger to personal health, follow the instructions.



On – Applies AC power to the system.

Depending on the type of power switch your device has, one of the following symbols may be used:



Off - Removes AC power from the system.



Standby – The On/Standby switch is in the standby position.

Modifications to Equipment

Do not make mechanical or electrical modifications to the equipment. Sun Microsystems is not responsible for regulatory compliance of a modified Sun product.

Placement of a Sun Product



Caution – Do not block or cover the openings of your Sun product. Never place a Sun product near a radiator or heat register. Failure to follow these guidelines can cause overheating and affect the reliability of your Sun product.



Caution – Noise level during normal operating condition is below 70Db(A). Noise level during over temperature condition may be above 70Db(A). Limit exposure during this temporary condition.

SELV Compliance

Safety status of I/O connections comply to SELV requirements.

Power Cord Connection



Caution – Sun products are designed to work with a line-to-neutral or line-to-line connection. To reduce the risk of electric shock, do not plug Sun products into any other type of power system. Contact your facilities manager or a qualified electrician if you are not sure what type of power is supplied to your building.



Caution – Not all power cords have the same current ratings. Household extension cords do not have overload protection and are not meant for use with computer systems. Do not use household extension cords with your Sun product.



Caution – Your Sun product is shipped with a grounding type (three-wire) power cord. To reduce the risk of electric shock, always plug the cord into a grounded power outlet.

The following caution applies only to devices with a Standby power switch:



Caution – The power switch of this product functions as a standby type device only. The power cord serves as the primary disconnect device for the system. Be sure to plug the power cord into a grounded power outlet that is nearby the system and is readily accessible. Do not connect the power cord when the power supply has been removed from the system chassis.

Lithium Battery



Caution – On Sun SC CPU boards, there is a lithium battery molded into the real-time clock, SGS No. MK48T59Y, MK48TXXB-XX, MK48T18-XXXPCZ, M48T59W-XXXPCZ, or MK48T08. Batteries are not customer replaceable parts. They may explode if mishandled. Do not dispose of the battery in fire. Do not disassemble it or attempt to recharge it.

Laser Compliance Notice

Sun products that use laser technology comply with Class 1 laser requirements.

Class 1 Laser Product
Luokan 1 Laserlaite
Klasse 1 Laser Apparat
Laser Klasse 1

CD-ROM/DVD-ROM



Caution – Use of controls, adjustments, or the performance of procedures other than those specified herein may result in hazardous radiation exposure.

Einhaltung sicherheitsbehördlicher Vorschriften

Auf dieser Seite werden Sicherheitsrichtlinien beschrieben, die bei der Installation von Sun-Produkten zu beachten sind.

Sicherheitsvorkehrungen

Treffen Sie zu Ihrem eigenen Schutz die folgenden Sicherheitsvorkehrungen, wenn Sie Ihr Gerät installieren:

- Beachten Sie alle auf den Geräten angebrachten Warnhinweise und Anweisungen.
- Vergewissern Sie sich, daß Spannung und Frequenz Ihrer Stromquelle mit der Spannung und Frequenz übereinstimmen, die auf dem Etikett mit den elektrischen Nennwerten des Geräts angegeben sind.
- Stecken Sie auf keinen Fall irgendwelche Gegenstände in Öffnungen in den Geräten. Leitfähige Gegenstände könnten aufgrund der möglicherweise vorliegenden gefährlichen Spannungen einen Kurzschluß verursachen, der einen Brand, Stromschlag oder Geräteschaden herbeiführen kann.

Symbole

Die Symbole in diesem Handbuch haben folgende Bedeutung:



Achtung – Gefahr von Verletzung und Geräteschaden. Befolgen Sie die Anweisungen.



Achtung – Hohe Temperatur. Nicht berühren, da Verletzungsgefahr durch heiße Oberfläche besteht.



Achtung – Gefährliche Spannungen. Anweisungen befolgen, um Stromschläge und Verletzungen zu vermeiden.

Ein – Setzt das System unter Wechselstrom.

Je nach Netzschaltertyp an Ihrem Gerät kann eines der folgenden Symbole benutzt werden:



Aus – Unterbricht die Wechselstromzufuhr zum Gerät.



Wartezustand (Stand-by-Position) - Der Ein-/Wartezustand-Schalter steht auf Wartezustand. Änderungen an Sun-Geräten.

Nehmen Sie keine mechanischen oder elektrischen Änderungen an den Geräten vor. Sun Microsystems, übernimmt bei einem Sun-Produkt, das geändert wurde, keine Verantwortung für die Einhaltung behördlicher Vorschriften

Aufstellung von Sun-Geräten



Achtung – Um den zuverlässigen Betrieb Ihres Sun-Geräts zu gewährleisten und es vor Überhitzung zu schützen, dürfen die Öffnungen im Gerät nicht blockiert oder verdeckt werden. Sun-Produkte sollten niemals in der Nähe von Heizkörpern oder Heizluftklappen aufgestellt werden.



Achtung – Unter normalen Betriebsbedingungen liegt der Geräuschpegel unter 70 Db(A). Bei erhöhten Temperaturen kann der Geräuschpegel bei über 70 Db(A) liegen. Minimieren Sie eine Überhitzung des Gerätes.

Einhaltung der SELV-Richtlinien

Die Sicherung der I/O-Verbindungen entspricht den Anforderungen der SELV-Spezifikation.

Anschluß des Netzkabels



Achtung – Sun-Produkte sind für die Verwendung mit einer Leiter-zu-Neutral- oder einer Leiter-zu-Leiter-Verbindung vorgesehen. Um die Stromschlaggefahr zu reduzieren, schließen Sie Sun-Produkte nicht an andere Stromquellen an. Ihr Betriebsleiter oder ein qualifizierter Elektriker kann Ihnen die Daten zur Stromversorgung in Ihrem Gebäude geben.



Achtung – Nicht alle Netzkabel haben die gleichen Nennwerte. Herkömmliche, im Haushalt verwendete Verlängerungskabel besitzen keinen Überlastungsschutz und sind daher für Computersysteme nicht geeignet.



Achtung – Ihr Sun-Gerät wird mit einem dreiadrigen Netzkabel für geerdete Netzsteckdosen geliefert. Um die Gefahr eines Stromschlags zu reduzieren, schließen Sie das Kabel nur an eine fachgerecht verlegte, geerdete Steckdose an.

Die folgende Warnung gilt nur für Geräte mit Wartezustand-Netzschalter:



Achtung – Der Ein/Aus-Schalter dieses Geräts schaltet nur auf Wartezustand (Stand-By-Modus). Um die Stromzufuhr zum Gerät vollständig zu unterbrechen, müssen Sie das Netzkabel von der Steckdose abziehen. Schließen Sie den Stecker des Netzkabels an eine in der Nähe befindliche, frei zugängliche, geerdete Netzsteckdose an. Schließen Sie das Netzkabel nicht an, wenn das Netzteil aus der Systemeinheit entfernt wurde.

Lithiumbatterie



Achtung – SC CPU-Karten von Sun verfügen über eine Echtzeituhr mit integrierter Lithiumbatterie (Teile-Nr. MK48T59Y, MK48TXXB-XX, MK48T18-XXXPCZ, M48T59W-XXXPCZ, oder MK48T08). Diese Batterie darf nur von einem qualifizierten Servicetechniker ausgewechselt werden, da sie bei falscher Handhabung explodieren kann. Werfen Sie die Batterie nicht ins Feuer. Versuchen Sie auf keinen Fall, die Batterie auszubauen oder wiederaufzuladen.

Einhaltung der Richtlinien für Laser

Sun-Produkte, die mit Laser-Technologie arbeiten, entsprechen den Anforderungen der Laser Klasse 1.

Class 1 Laser Product
Luokan 1 Laserlaite
Klasse 1 Laser Apparät
Laser Klasse 1

CD-ROM/DVD-ROM



Warnung – Die Verwendung von anderen Steuerungen und Einstellungen oder die Durchführung von Prozeduren, die von den hier beschriebenen abweichen, können gefährliche Strahlungen zur Folge haben.

Conformité aux normes de sécurité

Ce texte traite des mesures de sécurité qu'il convient de prendre pour l'installation d'un produit Sun Microsystems.

Mesures de sécurité

Pour votre protection, veuillez prendre les précautions suivantes pendant l'installation du matériel :

- Suivre tous les avertissements et toutes les instructions inscrites sur le matériel.
- Vérifier que la tension et la fréquence de la source d'alimentation électrique correspondent à la tension et à la fréquence indiquées sur l'étiquette de classification de l'appareil.
- Ne jamais introduire d'objets quels qu'ils soient dans une des ouvertures de l'appareil. Vous pourriez vous trouver en présence de hautes tensions dangereuses. Tout objet conducteur introduit de la sorte pourrait produire un court-circuit qui entraînerait des flammes, des risques d'électrocution ou des dégâts matériels.

Symboles

Vous trouverez ci-dessous la signification des différents symboles utilisés :



Attention: – risques de blessures corporelles et de dégâts matériels. Veuillez suivre les instructions.



Attention: – surface à température élevée. Évitez le contact. La température des surfaces est élevée et leur contact peut provoquer des blessures corporelles.



Attention: – présence de tensions dangereuses. Pour éviter les risques d'électrocution et de danger pour la santé physique, veuillez suivre les instructions.

MARCHE – Votre système est sous tension (courant alternatif).

Un des symboles suivants sera peut-être utilisé en fonction du type d'interrupteur de votre système:



ARRÊT - Votre système est hors tension (courant alternatif).



VEILLEUSE – L'interrupteur Marche/ Veilleuse est en position « Veilleuse ».

Modification du matériel

Ne pas apporter de modification mécanique ou électrique au matériel. Sun Microsystems n'est pas responsable de la conformité réglementaire d'un produit Sun qui a été modifié.

Positionnement d'un produit Sun



Attention: – pour assurer le bon fonctionnement de votre produit Sun et pour l'empêcher de surchauffer, il convient de ne pas obstruer ni recouvrir les ouvertures prévues dans l'appareil. Un produit Sun ne doit jamais être placé à proximité d'un radiateur ou d'une source de chaleur.



Attention: – Pendant le fonctionnement normal, le niveau de bruit est inférieur à 70 Db (A). Pendant l'utilisation à des températures élevées, il peut être supérieur à 70 Db (A). Limitez l'utilisation pendant ces conditions temporaires.

Conformité SELV

Sécurité : les raccordements E/S sont conformes aux normes SELV.

Connexion du cordon d'alimentation.



Attention: – Les produits Sun sont conçus pour fonctionner avec une connexion ligne à neutre ou ligne à ligne. Pour écarter les risques d'électrocution, ne pas brancher de produit Sun dans un autre type d'alimentation secteur. En cas de doute quant au type d'alimentation électrique du local, veuillez vous adresser au directeur de l'exploitation ou à un électricien qualifié.



Attention: – tous les cordons d'alimentation n'ont pas forcément la même puissance nominale en matière de courant. Les rallonges d'usage domestique n'offrent pas de protection contre les surcharges et ne sont pas prévues pour les systèmes d'ordinateurs. Ne pas utiliser de rallonge d'usage domestique avec votre produit Sun.



Attention: – votre produit Sun a été livré équipé d'un cordon d'alimentation à trois fils (avec prise de terre). Pour écarter tout risque d'électrocution, branchez toujours ce cordon dans une prise mise à la terre.

L'avertissement suivant s'applique uniquement aux systèmes équipés d'un interrupteur VEILLEUSE:



Attention: – le commutateur d'alimentation de ce produit fonctionne comme un dispositif de mise en veille uniquement. C'est la prise d'alimentation qui sert à mettre le produit hors tension. Veuillez donc à installer le produit à proximité d'une prise murale facilement accessible. Ne connectez pas la prise d'alimentation lorsque le châssis du système n'est plus alimenté.

Batterie au lithium



Attention: – sur les cartes SC CPU Sun, une batterie au lithium (référence MK48T59Y, MK48TXXB-XX, MK48T18-XXXPCZ, M48T59W-XXXPCZ, ou MK48T08.) a été moulée dans l'horloge temps réel SGS. Les batteries ne sont pas des pièces remplaçables par le client. Elles risquent d'exploser en cas de mauvais traitement. Ne pas jeter la batterie au feu. Ne pas la démonter ni tenter de la recharger.

Conformité aux certifications Laser

Les produits Sun qui font appel aux technologies lasers sont conformes aux normes de la classe 1 en la matière.

Class 1 Laser Product
Luokan 1 Laserlaite
Klasse 1 Laser Apparat
Laser Klasse 1

CD-ROM/DVD-ROM



Attention: – L'utilisation de contrôles, de réglages ou de performances de procédures autre que celle spécifiée dans le présent document peut provoquer une exposition à des radiations dangereuses.

Normativas de seguridad

El siguiente texto incluye las medidas de seguridad que se deben seguir cuando se instale algún producto de Sun Microsystems.

Precauciones de seguridad

Para su protección observe las siguientes medidas de seguridad cuando manipule su equipo:

- Siga todas las avisos e instrucciones marcados en el equipo.
- Asegúrese de que el voltaje y la frecuencia de la red eléctrica concuerdan con las descritas en las etiquetas de especificaciones eléctricas del equipo.
- No introduzca nunca objetos de ningún tipo a través de los orificios del equipo. Pueden haber voltajes peligrosos. Los objetos extraños conductores de la electricidad pueden producir cortocircuitos que provoquen un incendio, descargas eléctricas o daños en el equipo.

Símbolos

En este libro aparecen los siguientes símbolos:



Precaución – Existe el riesgo de lesiones personales y daños al equipo. Siga las instrucciones.



Precaución – Superficie caliente. Evite el contacto. Las superficies están calientes y pueden causar daños personales si se tocan.



Precaución – Voltaje peligroso presente. Para reducir el riesgo de descarga y daños para la salud siga las instrucciones.



Encendido – Aplica la alimentación de CA al sistema.

Según el tipo de interruptor de encendido que su equipo tenga, es posible que se utilice uno de los siguientes símbolos:



Apagado - Elimina la alimentación de CA del sistema.



En espera – El interruptor de Encendido/En espera se ha colocado en la posición de En espera.

Modificaciones en el equipo

No realice modificaciones de tipo mecánico o eléctrico en el equipo. Sun Microsystems no se hace responsable del cumplimiento de las normativas de seguridad en los equipos Sun modificados.

Ubicación de un producto Sun



Precaución – Para asegurar la fiabilidad de funcionamiento de su producto Sun y para protegerlo de sobrecalentamientos no deben obstruirse o taparse las rejillas del equipo. Los productos Sun nunca deben situarse cerca de radiadores o de fuentes de calor.



Precaución – El nivel de ruido en circunstancias normales de funcionamiento está por debajo de 70 Db (A). El nivel de ruido en circunstancias de temperatura excesiva podría estar por encima de 70 Db (A). En dichas circunstancias temporales limite la exposición.

Cumplimiento de la normativa SELV

El estado de la seguridad de las conexiones de entrada/salida cumple los requisitos de la normativa SELV.

Conexión del cable de alimentación eléctrica



Precaución – Los productos Sun están diseñados para funcionar con una conexión línea a neutra o línea a línea. Para reducir el riesgo de descarga eléctrica, no conecte los productos Sun a otro tipo de sistema de alimentación eléctrica. Póngase en contacto con el responsable de mantenimiento o con un electricista cualificado si no está seguro del sistema de alimentación eléctrica del que se dispone en su edificio.



Precaución – No todos los cables de alimentación eléctrica tienen la misma capacidad. Los cables de tipo doméstico no están provistos de protecciones contra sobrecargas y por tanto no son apropiados para su uso con computadores. No utilice alargadores de tipo doméstico para conectar sus productos Sun.



Precaución – Con el producto Sun se proporciona un cable de alimentación con toma de tierra. Para reducir el riesgo de descargas eléctricas conéctelo siempre a un enchufe con toma de tierra.

La siguiente advertencia se aplica solamente a equipos con un interruptor de encendido que tenga una posición "En espera":



Precaución – El interruptor de encendido de este producto funciona exclusivamente como un dispositivo de puesta en espera. El enchufe de la fuente de alimentación está diseñado para ser el elemento primario de desconexión del equipo. El equipo debe instalarse cerca del enchufe de forma que este último pueda ser fácil y rápidamente accesible. No conecte el cable de alimentación cuando se ha retirado la fuente de alimentación del chasis del sistema.

Batería de litio



Precaución – En las placas de SC CPU Sun hay una batería de litio insertada en el reloj de tiempo real, tipo SGS Núm. MK48T59Y, MK48TXXB-XX, MK48T18-XXXPCZ, M48T59W-XXXPCZ, o MK48T08. Las baterías no son elementos reemplazables por el propio cliente. Pueden explotar si se manipulan de forma errónea. No arroje las baterías al fuego. No las abra o intente recargarlas.

Aviso de cumplimiento con requisitos de láser

Los productos Sun que utilizan la tecnología de láser cumplen con los requisitos de láser de Clase 1.

Class 1 Laser Product
Luokan 1 Laserlaite
Klasse 1 Laser Apparat
Laser Klasse 1

CD-ROM/DVD-ROM



Precaución – El manejo de los controles, los ajustes o la ejecución de procedimientos distintos a los aquí especificados pueden exponer al usuario a radiaciones peligrosas.

GOST-R Certification Mark

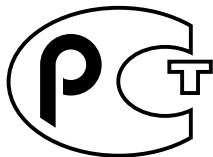

Nordic Lithium Battery Cautions

Norge



ADVARSEL – Litiumbatteri —
Ekspløsjonsfare. Ved utskifting benyttes kun
batteri som anbefalt av apparatfabrikanten.
Brukt batteri returneres apparatleverandøren.

Sverige



WARNING – Explosionsfara vid felaktigt
batteribyte. Använd samma batterityp eller
en ekvivalent typ som rekommenderas av
apparatillverkaren. Kassera använt batteri
enligt fabrikantens instruktion.

Danmark



ADVARSEL! – Litiumbatteri —
Ekspløsjonsfare ved fejlagtig håndtering.
Udskiftning må kun ske med batteri af samme
fabrikat og type. Levér det brugte batteri
tilbage til leverandøren.

Suomi



VAROITUS – Paristo voi räjähtää, jos se on
virheellisesti asennettu. Vaihda paristo
ainoastaan laitevalmistajan suosittelemaan
tyyppiin. Hävitä käytetty paristo valmistajan
ohjeiden mukaisesti.

Index

A

air flow floor panels, 2-3

C

cabinet

 placement, 2-3

 unpacking, 1-4

cable ties, 4-3

cabling

 grounding, 2-7

 power, 2-7

 signal, 2-8

circuit breakers, 2-9

console connection, 1-5

crating the cabinet, 6-3

D

DIN-type connector, 1-5

distribution unit, 2-4

E

ESD connections, 2-5

G

ground cable attaching, 2-6

grounding

 points, 2-6

 system, 2-4

I

I/O cable, 4-3

installation

 cabinet, 2-3

 completing, 4-3

 power cables, 2-7

K

kick plate assembly, 6-4

L

leveling feet, 4-4, 6-2, 6-6

M

moving the cabinet

 needed items, 6-1

 preparing the cabinet, 6-2

P

package configuration, software, 3-1

PDU receptacle grounding, 2-6
power cabling requirements, 2-7

R

raised floor, 2-3
receptacle grounding, 2-6
required tools, 6-1

S

safety precautions, 1-1
signal cabling, 2-8
software, installing packages, 3-1
strapping material, 6-1
system precautions, 1-2

T

tools required, 2-1

U

unpacking, 1-4