



Sun Fire™ High-End and Midrange Systems CPU/Memory Board Installation Guide

Sun Fire E25K/E20K Systems

Sun Fire 15K/12K Systems

Sun Fire E6900/E4900 Systems

Sun Fire 6800/4810/4800/3800 Systems

Locations of the CPU/Memory Boards

System	Number of CPU/Memory Board Slots	Slot Numbers	Location
Sun Fire E25K	18	SB0-SB17	Front and rear
Sun Fire 15K	18	SB0-SB17	Front and rear
Sun Fire E20K	9	SB0-SB8	Front
Sun Fire 12K	9	SB0-SB8	Front
Sun Fire E6900	6	SB0-SB5	Front
Sun Fire 6800	6	SB0-SB5	Front
Sun Fire E4900	3	SB0, SB2, SB4	Rear
Sun Fire 4810	3	SB0, SB2, SB4	Rear
Sun Fire 4800	3	SB0, SB2, SB4	Rear
Sun Fire 3800	2	SB0, SB2	Front



Caution – The CPU/Memory board is heavy and weighs approximately 17-22 pounds (7-9 kilograms). Take care when removing the board from the system.

Note – A CPU/Memory board field-replaceable unit (FRU) is for maintenance use only. FRUs must not be used to upgrade CPU performance in systems. Such usage can violate United States export regulations.

You can insert the CPU/Memory board into a powered-on system. However, the board will not be recognized by the system until the domain has been dynamically reconfigured to include the board, or re-initialized and rebooted. Refer to the dynamic reconfiguration manual for your product for complete DR procedures or the system administration manual for your product for complete procedures for re-initializing a domain.

Preparing to Install a CPU/Memory Board

Note – If you are installing an UltraSPARC® IV CPU/Memory board in a Sun Fire™ 6800/4800 system, additional upgrades are required for hardware, software, and firmware. Refer to the accompanying document, “Sun Fire High-End and Midrange Systems UltraSPARC IV CPU/Memory Board Upgrade Requirements” for the current upgrade requirements.



Caution – The Sun Fire 6800/4800 system might shut down if you do not install the additional upgrades that are required for the UltraSPARC IV CPU/Memory boards.

Note – If your system requires a software upgrade and a firmware upgrade, upgrade the firmware first. Upgrade the software second. Install the new CPU/Memory board only after you have upgraded the firmware and software.

Note – UltraSPARC IV CPU/Memory boards are not supported in Sun Fire™ 4810/3800 systems. Only earlier versions of CPU/Memory boards are supported in Sun Fire 4810/3800 systems.

1. **Place an ESD mat close to the system.**
2. **Wear an ESD strap and connect it to the system.**
3. **Inspect the new CPU/Memory board before inserting it into the system:**
 - a. **Inspect the connector on the board being installed.**

Remove the protective cover from the board connector. Check to see if the plastic is deformed or damaged, including both the pin holes and the fins. Insure there are no major (out of the normal) gaps between each pin row.

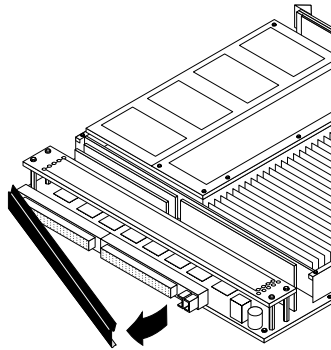

- b. Insure the CPU/Memory board alignment tabs are not bent.
 - c. Check the CPU/Memory board springfingers for damage.
 - d. Check the chassis springfingers for damage (SB5 for Sun Fire E6900/6800 and SB4 for Sun Fire E4900/4800 systems.)
4. Make sure that the new CPU/Memory board ejector levers are 90 degrees straight out from the board.

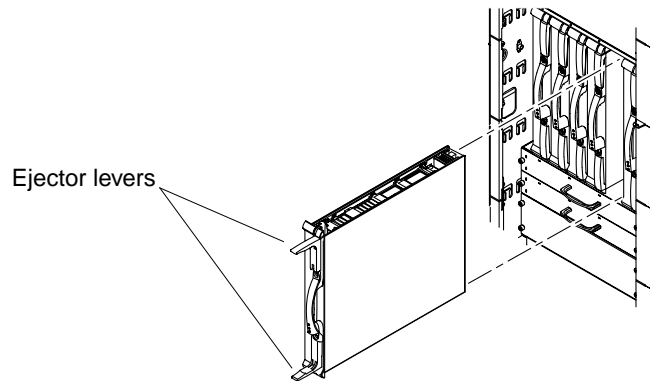

Installing a CPU/Memory Board

The top of the board is identified by a thin rail. The bottom of the board has a thicker rail. The board LEDs should be at the bottom of the handle when the board is inserted properly into the card cage.



Caution – You must insert a CPU/Memory board into the system within one minute of removing a board or filler board, or overheating will occur.

1. Remove the old board or filler board.
2. Insert the CPU/Memory board into the grooves of the proper slot:

-
- a. Hold the board by the handle vertically with one hand. Place the other hand under the bottom mounting rail.
 - b. Install the board in the chassis by tipping the handle of the board down so that the bottom rail meets the bottom chassis guide rail.
 - c. When the bottom board rail is in the chassis guide rail, tip the board back up and align the top rail into the chassis rail guide.
 - d. Slide the board into the chassis slowly until the ejector lever handles start to collapse inward.
3. Simultaneously rotate both ejectors until they are in the closed position (flush with the board).
When properly installed, the ejectors will lock automatically.
-

Note – The board will not be recognized by the system until the domain has been dynamically reconfigured to include the board, or re-initialized and rebooted.

4. Reconfigure the CPU/Memory board back into the system by either of the two following procedures:
 - Dynamically reconfigure the CPU/Memory board into the domain.
Refer to the dynamic reconfiguration manual for your product.
 - Power on the board and initialize the domain.
Refer to the system administration manual for your product.
-

Note – After reconfiguration, the Activated LED should be on (lit).

Preparing to Remove a CPU/Memory Board

If it is necessary to remove this board from a running system, use this procedure:

1. Be sure that you have a filler board or replacement board ready.
 2. Prepare the system to remove the CPU/Memory board by either of the following methods:
 - Refer to the system administration manual for your product for complete procedures for powering off the board.
 - If the board is being used by the Solaris Operating system, identify the board to be removed and dynamically reconfigure it out of the domain. Refer to the dynamic reconfiguration manual for your product for complete procedures.
-

Note – When the green Activated LED on the board is off and the amber or blue OK to remove LED is on, it is safe to continue.



Caution – The CPU/Memory board is heavy and weighs approximately 17-22 pounds (7-9 kilograms). Take care when removing the board from the system.

-
3. Place a grounded ESD mat close to the system.
 4. Wear an ESD strap and connect it to the system.

Removing a CPU/Memory Board



Caution – You must insert a replacement board or filler board into the system within one minute of removing a CPU/Memory board, or overheating will occur.

1. **Unlock the ejector levers on the CPU/Memory board with a Phillips No. 2 screwdriver.**
The ejectors will pop out slightly.
2. **Rotate the ejector levers simultaneously until they are 90 degrees straight out from the board.**
This action unseats the board from the connector.
3. **Remove the CPU/Memory board by pulling the board out of the slot.**
 - a. **Hold the handle while grasping the bottom rail with your other hand.**
 - b. **Slide the board along the track until the board is out of the card cage.**
Be careful not to touch neighboring boards.
4. **Place the board on the ESD mat.**
5. **Install a replacement board or filler board.**



Caution – Before the system is powered back on, make sure ALL slots in the CPU/Memory board slots are filled.

6. **If you installed a replacement CPU/Memory board, reconfigure the board back into the system by either of the two following procedures:**
 - Dynamically reconfigure the CPU/Memory board into the domain.
Refer to the dynamic reconfiguration manual for your product.
 - Power on the board and initialize the domain.
Refer to the system administration manual for your product.

Accessing Sun Documentation

You can view, print, or purchase a broad selection of Sun documentation, including localized versions, at:

<http://www.sun.com/documentation>

Contacting Sun Technical Support

If you have technical questions about this product that are not answered in this document, go to:

<http://www.sun.com/service/contacting>

Sun Welcomes Your Comments

Sun is interested in improving its documentation and welcomes your comments and suggestions. You can submit your comments by going to:

<http://www.sun.com/hwdocs/feedback>

Please include the title and part number of your document with your feedback:

Sun Fire High-End and Midrange Systems CPU/Memory Board Installation Guide, part number 806-2946-16

Copyright 2004 Sun Microsystems, Inc. All rights reserved. Use is subject to license terms. Third-party software, including font technology, is copyrighted and licensed from Sun suppliers. Portions may be derived from Berkeley BSD systems, licensed from U. of CA. Sun, Sun Microsystems, the Sun logo, Sun Fire, and Solaris are trademarks or registered trademarks of Sun Microsystems, Inc. in the U.S. and in other countries. All SPARC trademarks are used under license and are trademarks or registered trademarks of SPARC International, Inc. in the U.S. and in other countries. U.S. Government Rights—Commercial use. Government users are subject to the Sun Microsystems, Inc. standard license agreement and applicable provisions of the FAR and its supplements.

Copyright 2004 Sun Microsystems, Inc. Tous droits réservés. Distribué par des licences qui en restreignent l'utilisation. Le logiciel détenu par des tiers, et qui comprend la technologie relative aux polices de caractères, est protégé par un copyright et licencié par des fournisseurs de Sun. Des parties de ce produit pourront être dérivées des systèmes Berkeley BSD licenciés par l'Université de Californie. Sun, Sun Microsystems, le logo Sun, Sun Fire, et Solaris sont des marques de fabrique ou des marques déposées de Sun Microsystems, Inc. aux Etats-Unis et dans d'autres pays. Toutes les marques SPARC sont utilisées sous licence et sont des marques de fabrique ou des marques déposées de SPARC International, Inc. aux Etats-Unis et dans d'autres pays.



Sun Microsystems, Inc.
www.sun.com