



# Sun Fire™ Link Service Manual

---

Sun Microsystems, Inc.  
4150 Network Circle  
Santa Clara, CA 95054 U.S.A.  
650-960-1300

Part No. 806-1394-10  
December 2002, Revision A

Send comments about this document to: [docfeedback@sun.com](mailto:docfeedback@sun.com)

Copyright 2002 Sun Microsystems, Inc., 4150 Network Circle, Santa Clara, California 95054, U.S.A. All rights reserved.

Sun Microsystems, Inc. has intellectual property rights relating to technology embodied in the product that is described in this document. In particular, and without limitation, these intellectual property rights may include one or more of the U.S. patents listed at <http://www.sun.com/patents> and one or more additional patents or pending patent applications in the U.S. and in other countries.

This document and the product to which it pertains are distributed under licenses restricting their use, copying, distribution, and decompilation. No part of the product or of this document may be reproduced in any form by any means without prior written authorization of Sun and its licensors, if any.

Third-party software, including font technology, is copyrighted and licensed from Sun suppliers.

Parts of the product may be derived from Berkeley BSD systems, licensed from the University of California. UNIX is a registered trademark in the U.S. and in other countries, exclusively licensed through X/Open Company, Ltd.

Sun, Sun Microsystems, the Sun logo, AnswerBook2, docs.sun.com, Sun Fire, RSM, StorEdge, and Solaris are trademarks or registered trademarks of Sun Microsystems, Inc. in the U.S. and in other countries.

All SPARC trademarks are used under license and are trademarks or registered trademarks of SPARC International, Inc. in the U.S. and in other countries. Products bearing SPARC trademarks are based upon an architecture developed by Sun Microsystems, Inc.

The OPEN LOOK and Sun™ Graphical User Interface was developed by Sun Microsystems, Inc. for its users and licensees. Sun acknowledges the pioneering efforts of Xerox in researching and developing the concept of visual or graphical user interfaces for the computer industry. Sun holds a non-exclusive license from Xerox to the Xerox Graphical User Interface, which license also covers Sun's licensees who implement OPEN LOOK GUIs and otherwise comply with Sun's written license agreements.

Use, duplication, or disclosure by the U.S. Government is subject to restrictions set forth in the Sun Microsystems, Inc. license agreements and as provided in DFARS 227.7202-1(a) and 227.7202-3(a) (1995), DFARS 252.227-7013(c)(1)(ii) (Oct. 1998), FAR 12.212(a) (1995), FAR 52.227-19, or FAR 52.227-14 (ALT III), as applicable.

DOCUMENTATION IS PROVIDED "AS IS" AND ALL EXPRESS OR IMPLIED CONDITIONS, REPRESENTATIONS AND WARRANTIES, INCLUDING ANY IMPLIED WARRANTY OF MERCHANTABILITY, FITNESS FOR A PARTICULAR PURPOSE OR NON-INFRINGEMENT, ARE DISCLAIMED, EXCEPT TO THE EXTENT THAT SUCH DISCLAIMERS ARE HELD TO BE LEGALLY INVALID.

---

Copyright 2002 Sun Microsystems, Inc., 4150 Network Circle, Santa Clara, California 95054, Etats-Unis. Tous droits réservés.

Sun Microsystems, Inc. a les droits de propriété intellectuels relatants à la technologie incorporée dans le produit qui est décrit dans ce document. En particulier, et sans limitation, ces droits de propriété intellectuels peuvent inclure un ou plus des brevets américains énumérés à <http://www.sun.com/patents> et un ou les brevets plus supplémentaires ou les applications de brevet en attente dans les Etats-Unis et dans les autres pays.

Ce produit ou document est protégé par un copyright et distribué avec des licences qui en restreignent l'utilisation, la copie, la distribution, et la décompilation. Aucune partie de ce produit ou document ne peut être reproduite sous aucune forme, par quelque moyen que ce soit, sans l'autorisation préalable et écrite de Sun et de ses bailleurs de licence, s'il y en a.

Le logiciel détenu par des tiers, et qui comprend la technologie relative aux polices de caractères, est protégé par un copyright et licencié par des fournisseurs de Sun.

Des parties de ce produit pourront être dérivées des systèmes Berkeley BSD licenciés par l'Université de Californie. UNIX est une marque déposée aux Etats-Unis et dans d'autres pays et licenciée exclusivement par X/Open Company, Ltd.

Sun, Sun Microsystems, le logo Sun, AnswerBook2, docs.sun.com, Sun Fire, RSM, StorEdge, et Solaris sont des marques de fabrique ou des marques déposées de Sun Microsystems, Inc. aux Etats-Unis et dans d'autres pays.

Toutes les marques SPARC sont utilisées sous licence et sont des marques de fabrique ou des marques déposées de SPARC International, Inc. aux Etats-Unis et dans d'autres pays. Les produits portant les marques SPARC sont basés sur une architecture développée par Sun Microsystems, Inc.

L'interface d'utilisation graphique OPEN LOOK et Sun™ a été développée par Sun Microsystems, Inc. pour ses utilisateurs et licenciés. Sun reconnaît les efforts de pionniers de Xerox pour la recherche et le développement du concept des interfaces d'utilisation visuelle ou graphique pour l'industrie de l'informatique. Sun détient une licence non exclusive de Xerox sur l'interface d'utilisation graphique Xerox, cette licence couvrant également les licenciés de Sun qui mettent en place l'interface d'utilisation graphique OPEN LOOK et qui en outre se conforment aux licences écrites de Sun.

LA DOCUMENTATION EST FOURNIE "EN L'ÉTAT" ET TOUTES AUTRES CONDITIONS, DECLARATIONS ET GARANTIES EXPRESSES OU TACITES SONT FORMELLEMENT EXCLUES, DANS LA MESURE AUTORISÉE PAR LA LOI APPLICABLE, Y COMPRIS NOTAMMENT TOUTE GARANTIE IMPLICITE RELATIVE A LA QUALITE MARCHANDE, A L'APTITUDE A UNE UTILISATION PARTICULIERE OU A L'ABSENCE DE CONTREFAÇON.



Adobe PostScript

# Contents

---

## **Preface 1-xi**

## **1. Safety and Tools Requirements 1-1**

1.1 Safety Precautions 1-1

1.2 Symbols 1-3

1.3 System Precautions 1-4

1.4 Filler Boards and Filler Panels 1-5

1.4.1 Sun Fire Link Assembly for a Sun Fire 6800 System 1-5

1.4.2 Sun Fire Link Assembly for a Sun Fire 15K/12K System 1-5

1.5 Handling Boards and Assemblies 1-5

1.6 Tools Required 1-6

## **2. Removing and Replacing Components in a Sun Fire 6800 System 2-1**

2.1 Handling Boards and Assemblies 2-1

2.2 Filler Boards, Filler Panels, and CompactPCI Filler Cards 2-2

2.3 Sun Fire Link Assembly 2-3

2.3.1 CompactPCI Slots in a Sun Fire Link Assembly 2-4

2.3.2 Sun Fire Link Assembly Status LEDs 2-6

2.3.3 Removing and Replacing Sun Fire Link Assemblies 2-6

2.3.3.1 Removing a Sun Fire Link Assembly 2-6

2.3.3.2	Installing a Sun Fire Link Assembly	2-8
2.4	Sun Fire Link Optical Module	2-9
2.4.1	Sun Fire Link Optical Module LEDs	2-11
2.4.2	Removing and Replacing a Sun Fire Link Optical Module	2-13
2.4.2.1	Removing a Sun Fire Link Optical Module	2-13
2.4.2.2	Installing a Sun Fire Link Optical Module	2-14
2.5	Sun Fire Link Cables	2-14
2.5.1	Cabling Sun Fire Link Systems	2-15
<b>3.</b>	<b>Removing and Replacing Components in a Sun Fire 15K/12K System</b>	<b>3-1</b>
3.1	Handling Boards and Assemblies	3-1
3.2	Filler Boards, Filler Panels, and CompactPCI Filler Cards	3-2
3.3	Sun Fire Link Assembly	3-3
3.3.1	CompactPCI Slots in a Sun Fire Link Assembly	3-6
3.3.2	Sun Fire Link Assembly LEDs	3-7
3.3.3	Sun Fire Link ASIC Port IDs	3-7
3.3.4	Removing and Replacing Sun Fire Link Assemblies	3-9
3.3.4.1	Removing a Sun Fire Link Assembly	3-9
3.3.4.2	Installing a Sun Fire Link Assembly	3-10
3.4	Sun Fire Link Optical Modules	3-11
3.4.1	Sun Fire Link Optical Module LEDs	3-13
3.4.2	Removing and Replacing a Sun Fire Link Optical Module	3-15
3.4.2.1	Removing a Sun Fire Link Optical Module	3-15
3.4.2.2	Installing a Sun Fire Link Optical Module	3-16
3.5	Sun Fire Link Cables	3-17
3.5.0.1	Cabling Sun Fire Link Systems	3-18
<b>A.</b>	<b>Illustrated Parts Breakdown</b>	<b>A-1</b>
<b>B.</b>	<b>Regulatory Compliance Statements</b>	<b>B-1</b>

## **Index Index-1**



# Figures

---

- FIGURE 2-1 Sun Fire 6800 System With Two Sun Fire Link Assemblies Installed 2-4
- FIGURE 2-2 Sun Fire Link Assembly for Sun Fire 6800 Systems 2-5
- FIGURE 2-3 Sun Fire Link Assembly 2-7
- FIGURE 2-4 Replacing a Sun Fire Link Assembly From a Sun Fire 6800 System 2-8
- FIGURE 2-5 Sun Fire Link Optical Module 2-10
- FIGURE 2-6 Card LEDs on the Optical Module. 2-12
- FIGURE 2-7 Replacing a Sun Fire Link Optical Module in a Sun Fire Link Assembly for Sun Fire 6800 Systems 2-13
- FIGURE 2-8 Sun Fire Link Cable 2-15
- FIGURE 3-1 Sun Fire Link Assembly Locations—Front (Side 0) 3-4
- FIGURE 3-2 Sun Fire Link Assembly Locations—Rear (Side 1) 3-5
- FIGURE 3-3 Sun Fire Link Assembly for Sun Fire 15K/12K Systems 3-6
- FIGURE 3-4 Sun Fire Link Assembly Locations and Corresponding ASIC IDs 3-8
- FIGURE 3-5 Replacing a Sun Fire Link Assembly in a Sun Fire 15K/12K System 3-10
- FIGURE 3-6 Sun Fire Link Optical Module 3-12
- FIGURE 3-7 Card LEDs on the Optical Module 3-14
- FIGURE 3-8 Replacing an Optical Module in a Sun Fire Link Assembly for Sun Fire 15K/12K Systems 3-16
- FIGURE 3-9 Sun Fire Link Cable 3-18
- FIGURE A-1 Sun Fire Link Assembly for Sun Fire 6800 Systems (F501-6094-04) A-2
- FIGURE A-2 Sun Fire Link Assembly for Sun Fire 15K/12K Systems (F501-6303-07) A-2

FIGURE A-3 Sun Fire Link Optical Module (Paroli) (F375-0093-03) A-3

FIGURE A-4 Sun Fire Link Optical Cable (F537-1022-02, F537-1023-02, and F537-1024-02) A-3



# Tables

---

TABLE 1-1	Safety Precautions	1-2
TABLE 1-2	Symbols	1-3
TABLE 2-1	I/O Assembly LED Functions	2-6
TABLE 2-2	Sun Fire Link Slot LED Functions	2-11
TABLE 2-3	Card LEDs on the Optical Module	2-12
TABLE 3-1	Sun Fire Link Slot LED Functions	3-7
TABLE 3-2	Sun Fire Link 15K/12K System Port IDs	3-8
TABLE 3-3	Sun Fire Link Slot LED Functions	3-13
TABLE 3-4	Card LEDs on the Optical Module	3-14
TABLE A-1	List of Replacable Components	A-1



# Preface

---

This book describes how to remove and install field-replaceable units (FRUs) that are part of the Sun Fire™ Link Interconnect system. For example, how to remove and install boards, cards, assemblies, and modules is covered in this book. This book also presents a functional description of the system.

---

## Before You Read This Book

In order to fully use the information in this document, you must have thorough knowledge of your Sun Fire 6800 and 15K/12K systems. Refer to the documentation that came with your systems.

---

# How This Book Is Organized

Chapter 1 describes the safety precautions and tools you will need.

Chapter 2 describes how to install and remove the Sun Fire Link assembly in a Sun Fire 6800 system and how to install and remove Sun Fire Link optical modules in the assembly.

Chapter 3 describes how to install and remove the Sun Fire Link assembly in a Sun Fire 15K system and how to install and remove Sun Fire Link optical modules in the assembly.

Appendix A provides part numbers and illustrations of the field-replaceable units.

Appendix B provides applicable regulatory and safety messages.

---

# Using UNIX Commands

This document might not contain information on basic UNIX® commands and procedures such as shutting down the system, booting the system, and configuring devices.

See one or more of the following for this information:

- *Solaris Handbook for Sun Peripherals*
- AnswerBook2™ online documentation for the Solaris™ operating environment
- Other software documentation that you received with your system

---

# Typographic Conventions

Typeface	Meaning	Examples
AaBbCc123	The names of commands, files, and directories; on-screen computer output	Edit your <code>.login</code> file. Use <code>ls -a</code> to list all files. % You have mail.
<b>AaBbCc123</b>	What you type, when contrasted with on-screen computer output	% <b>su</b> Password:
<i>AaBbCc123</i>	Book titles, new words or terms, words to be emphasized. Replace command-line variables with real names or values.	Read Chapter 6 in the <i>User's Guide</i> . These are called <i>class</i> options. You <i>must</i> be superuser to do this. To delete a file, type <code>rm filename</code> .

---

# Shell Prompts

Shell	Prompt
C shell	<i>machine-name%</i>
C shell superuser	<i>machine-name#</i>
Bourne shell and Korn shell	\$
Bourne shell and Korn shell superuser	#

---

## Related Documentation

Application	Title	art Number
Overview	<i>Sun Fire™ Link System Overview Manual</i>	816-0697
Task Map	<i>Sun Fire™ Link Getting Started and Task Map</i>	816-0041
Site Planning	<i>Sun Fire™ Link Systems Site Planning Guide</i>	816-6592
Hardware Installation	<i>Sun Fire™ Link Hardware Installation Guide</i>	806-1396
Software Installation	<i>Sun Fire™ Link Software Installation Guide</i>	806-1401
System Administration	<i>Sun Fire™ Link Fabric Administrator's Guide</i>	806-1405
Switch Hardware and Software	<i>Sun Fire™ Link Switch Installation and Service Manual</i>	806-1397
Late Breaking Information	<i>Sun Fire™ Link Interconnect Product Notes</i>	806-1404

---

## Accessing Sun Documentation Online

A broad selection of Sun system documentation is located at:

<http://www.sun.com/products-n-solutions/hardware/docs>

A complete set of Solaris documentation and many other titles are located at:

<http://docs.sun.com>

---

## Sun Welcomes Your Comments

Sun is interested in improving its documentation and welcomes your comments and suggestions. You can email your comments to Sun at:

[docfeedback@sun.com](mailto:docfeedback@sun.com)

Please include the part number (806-1394-10) of your document in the subject line of your email.

---

## Notes, Cautions, and Warnings



---

**Caution** – This equipment contains lethal voltage. Accidental contact with centerplane, card cage, and drive areas can result in serious injury or death.

---



---

**Caution** – Improper handling by unqualified personnel can cause serious damage to this equipment. Unqualified personnel who tamper with this equipment may be held liable for any resultant damage to the equipment.

---

---

## United States Export Control Laws Notice

Product covered by and information contained in this service manual are controlled by U.S. Export Control laws and may be subject to the export or import laws in other countries. Nuclear, missile, chemical biological weapons, or nuclear maritime end uses or end users, whether direct or indirect, are strictly prohibited. Export or re-export to countries subject to U.S. embargo or to entities identified on U.S. export exclusion lists, including but not limited to the denied persons and specially designated nationals lists is strictly prohibited. Use of any spare or replacement CPUs is limited to repair or one-for-one replacement of CPUs in products exported in compliance with U.S. export laws. Use of CPUs as product upgrades unless authorized by the U.S. Government is strictly prohibited.





# Safety and Tools Requirements

---

This chapter describes the safety and system precautions you must take when servicing the Sun Fire Link hardware. It also lists the tools and equipment you will need.

- Section 1.1, “Safety Precautions” on page 1-1
- Section 1.2, “Symbols” on page 1-3
- Section 1.3, “System Precautions” on page 1-4
- Section 1.4, “Filler Boards and Filler Panels” on page 1-5
- Section 1.5, “Handling Boards and Assemblies” on page 1-5
- Section 1.6, “Tools Required” on page 1-6

---

## 1.1 Safety Precautions

For your protection, observe the following safety precautions when setting up your equipment:

- Follow all cautions, warnings, and instructions marked on the equipment.
- Never push objects of any kind through openings in the equipment as they may touch dangerous voltage points or short out components that could result in fire or electric shock.
- Refer servicing of equipment to qualified personnel.

To protect both yourself and the equipment, observe the following safety precautions:

**TABLE 1-1** Safety Precautions







<b>Item</b>	<b>Problem</b>	<b>Precaution</b>
ESD wrist or foot strap	Electro-Static Discharge (ESD)	Connect the ESD connector to your system and wear a conductive wrist strap or foot strap when handling printed circuit boards.
ESD mat	ESD	An approved ESD mat provides protection from static damage when used with a wrist strap or foot strap. The mat also cushions and protects small parts that are attached to printed circuit boards.

---

## 1.2 Symbols





The following symbols mean:

TABLE 1-2 Symbols

Symbol	Description	Meaning
	<b>CAUTION</b>	Hazardous voltages are present. To reduce the risk of electrical shock and danger, follow the instructions.
	<b>CAUTION</b>	Risk of personal injury. To reduce the risk, follow the instructions.
	<b>CAUTION</b>	Risk of equipment damage. To reduce the risk, follow the instructions.
	<b>SURFACE</b>	<b>CAUTION:</b> Hot surfaces. Avoid contact. Surfaces are hot and may cause personal injury if touched.
	<b>AC</b>	A terminal to which alternating current or voltage may be applied.
	<b>SYSTEM POWER</b>	System is receiving DC power. When the power LED is lit the system is operating normally.
	<b>BOARD OR COMPONENT POWER</b>	Module or component is receiving DC power. When the power LED for the module or component (top green LED) is lit, the component is operating normally.

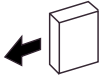
---

TABLE 1-2 Symbols (Continued)

Symbol	Description	Meaning
	<b>FAULT</b>	System has detected a hardware failure. When the fault LED (middle, amber) is lit, the system has detected a hardware failure.
	<b>OK TO REMOVE</b>	You can safely remove module or component from the system when the Removal OK LED (bottom, amber) is lit.
	<b>PROTECTIVE EARTH</b>	Earth ground.
	<b>CHASSIS</b>	Frame or chassis ground.
	<b>FUSE REPLACEMENT MARKING</b>	For continued protection against risk of fire and electric shock, replace <b>ONLY</b> with fuse of the same type and rating.
	<b>OPTICAL LASER WARNING</b>	<b>CAUTION:</b> It is unsafe to look directly into uncovered connector receptacles on active optical modules as it can be injurious to your eyesight.

## 1.3 System Precautions

Ensure that the voltage and frequency of the power outlet to be used matches the electrical rating labels on the equipment.

Wear an ESD wrist/foot strap when handling any magnetic storage devices, Sun Fire Link assemblies, or other printed circuit boards.

Use only properly grounded power outlets as described in *Sun Fire Systems Installation Guide*.



---

**Caution** – DO NOT make mechanical or electrical modifications to the cabinet. Sun Microsystems™ is not responsible for regulatory compliance of modified cabinets.

---



---

**Caution** – The chassis AC power cord(s) must remain connected to ensure a proper ground.

---

---

## 1.4 Filler Boards and Filler Panels

### 1.4.1 Sun Fire Link Assembly for a Sun Fire 6800 System

You must install a filler panel, which covers only the front of the board slot, within one minute of removing the Sun Fire Link assembly from a powered-on system. The assembly must also contain filler boards to fill the empty CompactPCI slots.

### 1.4.2 Sun Fire Link Assembly for a Sun Fire 15K/12K System

You must install a filler panel, which covers only the front of the board slot, within one minute of removing the Sun Fire Link assembly from a powered-on system. The assembly must also contain filler boards to fill the empty CompactPCI slots.

---

## 1.5 Handling Boards and Assemblies



---

**Caution** – The chassis AC power cord must remain connected to ensure a proper ground.

---



---

**Caution** – The Sun Fire Link assemblies, their modules, and cards have surface-mount components that can be broken by flexing the assemblies.

---

To minimize the amount of flexing, observe the following precautions:

- Hold the board only by the edges near the middle of the board, where the board stiffener is located. Do not hold the board *only* at the ends.
- When removing the board from an antistatic bag, keep the board vertical until you lay it on the Sun ESD mat.
- Do not place the board on a hard surface. Use a cushioned antistatic mat. The board connectors and components have very thin pins that bend easily.
- Be careful of small parts located on the component side of the board.
- Do not use an oscilloscope probe on the components. The soldered pins are easily damaged or shorted by the probe point.
- Transport the board in an antistatic bag.



---

**Caution** – The heat sinks on the assembly can be damaged by incorrect handling. Do not touch the heatsinks while installing or removing the board. Hold the board only by the edges. If a heatsink is loose or broken, obtain a replacement assembly.

---



---

**Caution** – The heatsinks on the assembly can be damaged by improper packaging. When storing or shipping the board, ensure that the heatsinks have sufficient protection.

---



---

**Caution** – The system is sensitive to static electricity. To prevent damage to the assembly, connect an antistatic wrist strap between you and the system.

---

---

## 1.6 Tools Required

For the procedures in this book, you will need these tools:

- Screwdriver, Phillips #2
- ESD mat
- Grounding wrist/foot strap

# Removing and Replacing Components in a Sun Fire 6800 System

---

This chapter provides removal and replacement procedures for field-replaceable components on a Sun Fire Link Assembly in a Sun Fire 6800 system.

To protect both yourself and the equipment, make sure you follow the precautions in Chapter 1.

This chapter contains the following sections:

- Section 2.1, “Handling Boards and Assemblies” on page 2-1
- Section 2.2, “Filler Boards, Filler Panels, and CompactPCI Filler Cards” on page 2-2
- Section 2.3, “Sun Fire Link Assembly” on page 2-3
- Section 2.5, “Sun Fire Link Cables” on page 2-14

---

## 2.1 Handling Boards and Assemblies



---

**Caution** – The chassis AC power cord must remain connected to ensure a proper ground.

---



---

**Caution** – The system is sensitive to static electricity. To prevent damage to the assembly, connect an antistatic wrist strap between you and the system.

---



---

**Caution** – The Sun Fire Link assembly, its modules, and its cards have surface-mount components that can be broken if you flex the assemblies.

---

To minimize the amount of board flexing, observe the following precautions:

- Hold the board only by the edges near the middle of the board, where the board stiffener is located. Do not hold the board *only* at the ends.
- When removing the board from an antistatic bag, keep the board vertical until you lay it on the Sun ESD mat.
- Do not place the board on a hard surface. Use a cushioned antistatic mat. The board connectors and components have very thin pins that bend easily.
- Be careful of small parts located on the component side of the board.
- Do not use an oscilloscope probe on the components. The soldered pins are easily damaged or shorted by the probe point.
- Transport the board in an antistatic bag.



---

**Caution** – The heatsinks on the assembly can be damaged by incorrect handling. Do not touch the heatsinks while replacing or removing the board. Hold the board only by the edges. If a heatsink is loose or broken, obtain a replacement board.

---



---

**Caution** – The heatsinks on the assembly can be damaged by improper packaging. When storing or shipping the board, ensure that the heatsinks have sufficient protection.

---

---

**Note** – The Sun Fire Link assembly and Sun Fire Link optical modules can be inserted into a powered-on system. A new assembly or optical module will not be recognized by the system until the domain has been re-initialized and rebooted. Refer to the *Sun Management Center 3.0 Software Supplement for Sun Fire Link* for complete procedures for initializing a domain.

---

---

## 2.2 Filler Boards, Filler Panels, and CompactPCI Filler Cards

To prevent the system from overheating, see Section 1.4, “Filler Boards and Filler Panels” on page 1-5 for procedures you must follow when removing the Sun Fire Link assembly from a system.





---

**Caution** – You must install a filler panel which covers only the front of the assembly slot, if the system is to be powered up without the Sun Fire Link assembly installed.

---



---

**Caution** – Make sure all slots in the Sun Fire Link assembly are filled: by cards OR filler boards.

---

---

## 2.3 Sun Fire Link Assembly

Each Sun Fire Link assembly has:

- Two hot-swappable Sun Fire Link optical module slots
- Two hot-swappable CompactPCI slots that may be used for I/O

The Sun Fire Link assembly is based on a Sun Fire 6800 I/O assembly. Sun Fire Link assemblies must be installed in the two upper slots (IB8 and IB9) in a Sun Fire 6800 system (FIGURE 2-1).

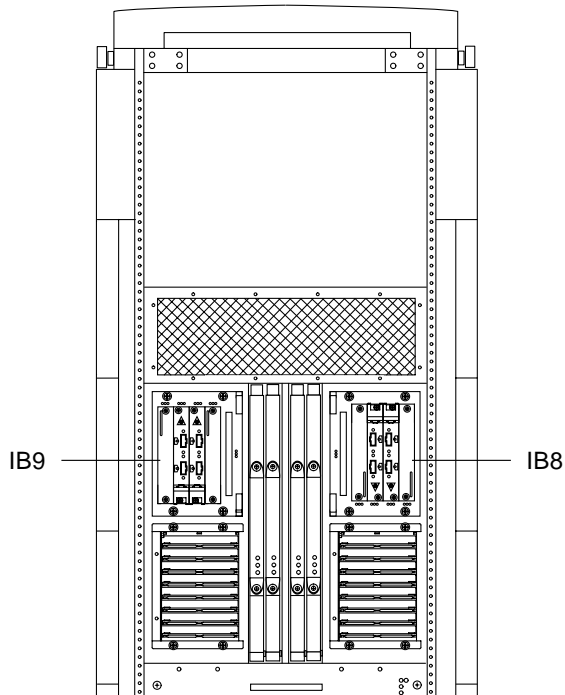

**FIGURE 2-1** Sun Fire 6800 System With Two Sun Fire Link Assemblies Installed

## 2.3.1 CompactPCI Slots in a Sun Fire Link Assembly

Each Sun Fire Link assembly (FIGURE 2-2) contains four slots. Slot 0 and Slot 3 are standard CompactPCI slots. Slots 1 and 2 are used only for Sun Fire Link optical modules.

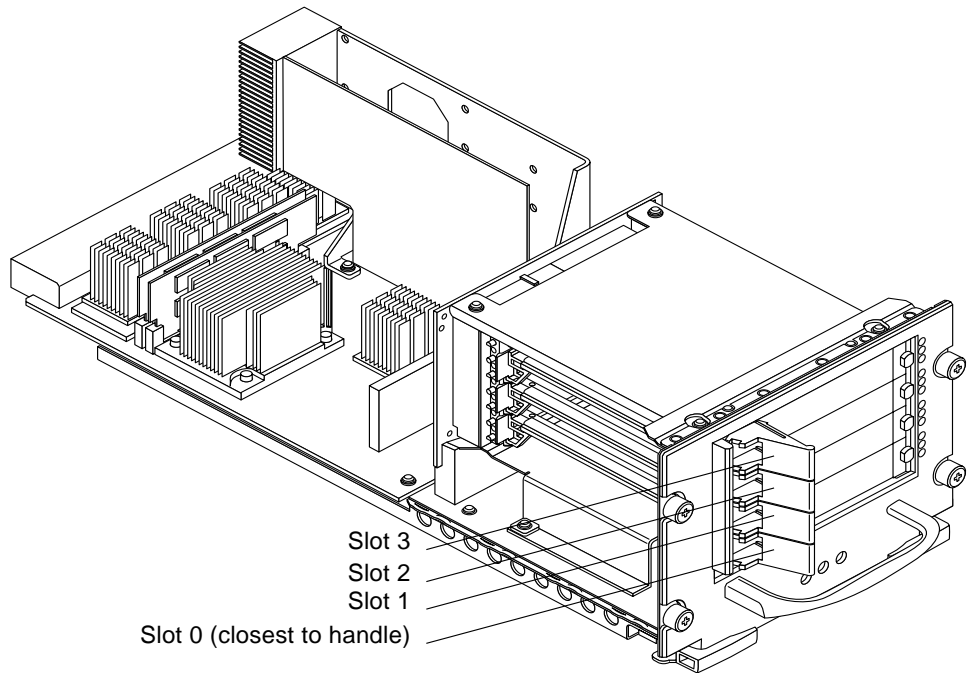

**FIGURE 2-2** Sun Fire Link Assembly for Sun Fire 6800 Systems

---



**Note** – The view in FIGURE 2-2 shows the assembly as you would see it sitting flat on a table. The assembly is installed turned 90 degrees from the angle shown. It is always installed so that the handle is closest to the center of the chassis. In slot IB8 the assembly is installed rotated 90 degrees clockwise from FIGURE 2-2. In slot IB9, the assembly is installed rotated 90 degrees counterclockwise from FIGURE 2-2.

---

## 2.3.2 Sun Fire Link Assembly Status LEDs

Each Sun Fire Link Assembly has three LEDs that provide power, fault, and removal status. TABLE 2-1 notes the LED functions.

TABLE 2-1 I/O Assembly LED Functions

LED	On	Off
Power LED (green)	 Power is on; you cannot remove the Sun Fire Link assembly when this LED is on.	Power is off; you can remove the Sun Fire Link assembly when this LED is off.
Fault LED (amber)	 Internal fault	No internal fault
Removal OK LED (amber)	 You can safely remove the Sun Fire Link Assembly under hot-swap conditions.	Do not remove the Sun Fire Link assembly.

## 2.3.3 Removing and Replacing Sun Fire Link Assemblies

### 2.3.3.1 Removing a Sun Fire Link Assembly

1. **Have the customer administrator power off the Sun Fire Link assembly.**

Refer to the *Sun Fire 6800/4810/4800/3800 Systems Platform Administration Manual* for complete procedures for powering off the assembly.

2. **Attach a wrist strap or foot strap. Connect the ESD strap to the system. Place a grounded ESD mat close to the system.**



---

**Caution** – The system is sensitive to static electricity.

---

3. **Loosen the four Phillips captive screws (FIGURE 2-3).**

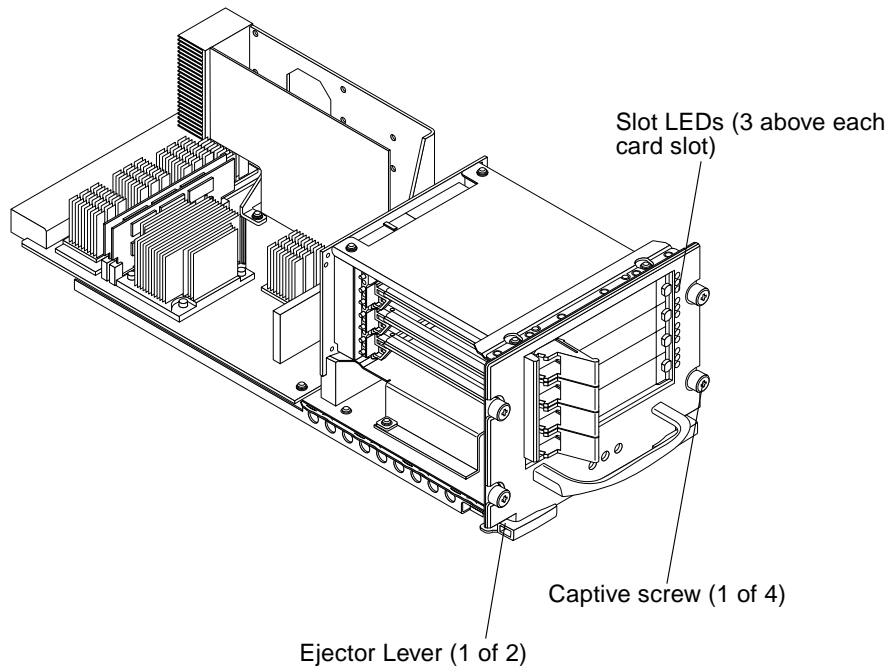

FIGURE 2-3 Sun Fire Link Assembly

- 4. Simultaneously pull the two ejector levers outward to unseat the assembly.**  
The ejector levers must be perpendicular to the assembly. This action releases the board from the connectors.
- 5. With one hand holding the handle and the other hand beneath the assembly for support, slide the assembly out of the opening (FIGURE 2-4).**
- 6. Place the assembly on an ESD mat that is on a work surface.**



---

**Caution** – To prevent overheating, you must install a filler panel or a replacement assembly, within one minute of removing the Sun Fire Link assembly from the system.

---

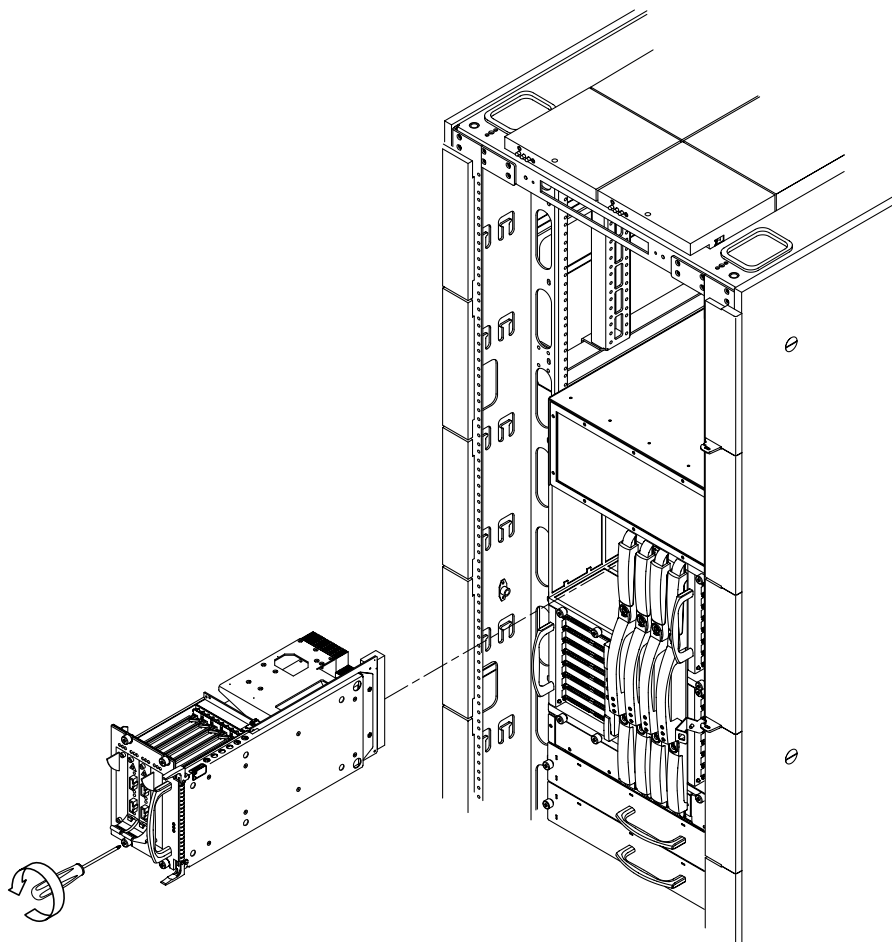

FIGURE 2-4 Replacing a Sun Fire Link Assembly From a Sun Fire 6800 System

### 2.3.3.2 Installing a Sun Fire Link Assembly

---

**Note** – You can insert the assembly into a powered-on system. The assembly can be configured into the cluster using dynamic reconfiguration (DR). Refer to any dynamic reconfiguration documentation that came with your system.

---

1. **Attach a wrist strap or foot strap. Connect the ESD strap to the system. Place an ESD mat close to the system.**

---

**Note** – You must install Sun Fire Link assemblies in the top slots (IB8 and IB9) due to cooling requirements.

---

2. **Remove the filler panel, if installed, from the front of the assembly location.**
3. **Move the ejector levers on the I/O assembly to the open (perpendicular) position.**
4. **Line up the assembly with the opening.**
5. **Slide the assembly into the card guides, holding the assembly with one hand on the handle and the other hand underneath the assembly, (FIGURE 2-4).**

The ejector levers should be in the open position.



---

**Note** – DO NOT FORCE any assembly into an opening; this can cause damage to the assembly and system. The assembly should insert and seat smoothly. If it binds, remove it and inspect the card cage slot for any obvious obstructions.

---

6. **After the assembly is completely into the card cage, simultaneously press the two ejectors inwards into the closed position.**
7. **Tighten the four captive Phillips screws (FIGURE 2-3).**
8. **Power on the assembly.**

Refer to the *Sun Fire 6800/4810/4800/3800 Systems Platform Administration Manual* for complete procedures for powering on the assembly.

---

## 2.4 Sun Fire Link Optical Module

Optical modules must be installed in slots 1 and 2 (the two center slots) in a Sun Fire Link assembly. The optical module is *hot swappable*; it is recognized during operation.

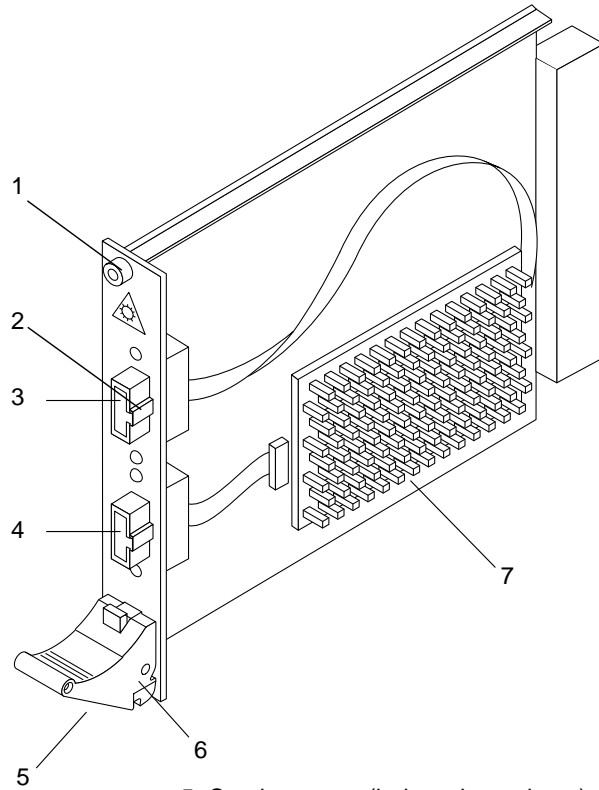

- 1. Captive screw
- 2. Alignment ridge
- 3. Receive connector
- 4. Transmit connector
- 5. Captive screw (below ejector lever)
- 6. Ejector Lever
- 7. Heat Sink



**FIGURE 2-5** Sun Fire Link Optical Module



## 2.4.1 Sun Fire Link Optical Module LEDs

There are three LEDs (*slot LEDs*) for each card slot on the Sun Fire Link assembly (FIGURE 2-3). When installed in slot IB8, the LEDs are at the bottom of the assembly. When installed in slot IB9, they are at the top of the assembly. TABLE 2-2 notes the slot LED functions.

TABLE 2-2 Sun Fire Link Slot LED Functions

LED		On	Off
Power LED (green)		Power is on; you cannot remove the optical module when this LED is on.	Power is off; you can remove the optical module when this LED is off.
Fault LED (amber)		Internal fault	No internal fault
Removal OK LED (amber)		You can safely remove the optical module under hot-swap conditions.	Do not remove the optical module.

Besides the LEDs that are located on the assembly, each optical link module has three LEDs (*card LEDs*) on the module itself (FIGURE 2-6 and TABLE 2-3). A single green LED indicates whether or not power is applied; paired green and amber LEDs convey link status and configuration

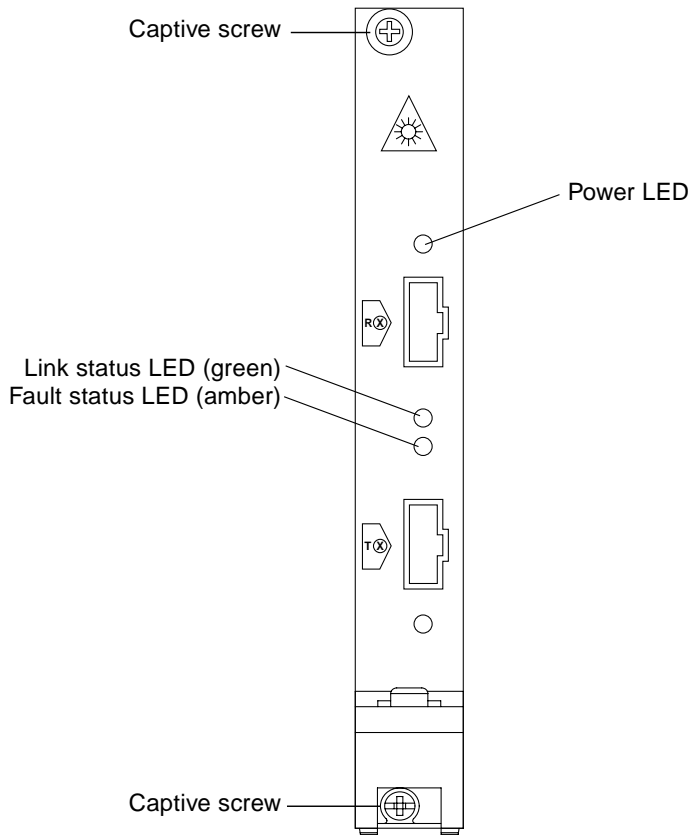

**FIGURE 2-6** Card LEDs on the Optical Module.

**TABLE 2-3** Card LEDs on the Optical Module

<b>Link Status LED (Green)</b>	<b>Fault Status LED (Amber)</b>	<b>Meaning</b>
OFF	OFF	No External Link detected. No valid Rx Clock detected
ON	OFF	Link operational: Valid Rx clock received. Remote ID validated.
ON	ON	Degraded link detected: This combination indicates that an error threshold has been exceeded. The link is still operational but performance may be degraded.
BLINKING	OFF	Link is in the process of moving to the operational state.

## 2.4.2 Removing and Replacing a Sun Fire Link Optical Module

Each optical module (FIGURE 2-5) provides one optical link.

### 2.4.2.1 Removing a Sun Fire Link Optical Module

1. Ensure that either a replacement module or filler board is immediately available.
2. Attach a wrist strap or foot strap. Connect the ESD strap to the system. Place a grounded ESD mat close to the system.
3. Disconnect and label any cables from the card that is being removed.
4. Loosen the two captive screws, one at each end of the optical module.
5. Press the lever outward to eject the optical module.
6. Slide the card out of the slot.

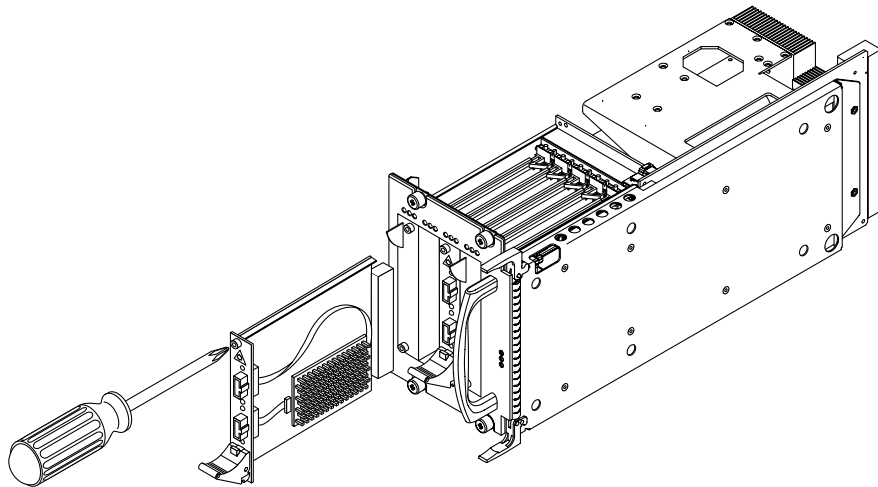

**FIGURE 2-7** Replacing a Sun Fire Link Optical Module in a Sun Fire Link Assembly for Sun Fire 6800 Systems

7. Install a filler card in the empty slot if you will not be installing another optical module within one minute.

---

**Note** – You must have either a filler card or an optical module installed in the two optical module slots (slots 1 and 2) and a filler card or another CompactPCI I/O card in slots 0 and 3.

---

### 2.4.2.2 Installing a Sun Fire Link Optical Module

1. **Attach a wrist strap or foot strap. Connect the ESD strap to the system.**
2. **Remove the filler panel.**
3. **Push the ejector lever out to the open position.**
4. **Hold the optical module by the two side edges or the front panel and slide the module into the slot in between the two guides. (FIGURE 2-7).**

The cuts in the lever of the optical module must align with the square cutouts on the Sun Fire Link assembly.

5. **Press on the front panel to completely seat the module in the Sun Fire Link assembly.**
6. **Push the ejector lever in to lock the lever. You should feel it click.**
7. **Tighten the two captive screws, one at each end of the module.**
8. **Power on the card.**

Refer to the *Sun Fire 6800/4810/4800/3800 Systems Platform Administration Manual* and use the procedure for powering on a CompactPCI card.

---

## 2.5 Sun Fire Link Cables

The Sun Fire Link cables have the following features:

- Cables are available in 5-, 12-, and 20-meter lengths.
- Each cable has two connectors at each end (FIGURE 2-8).
  - The transmit connector (Tx) is white.
  - The receive connector (Rx) is black.
- Each cable is labeled with a serial number that aids in cable route tracing (FIGURE 2-8).
- Cable changes can be made while the system is operational. Changes should be made consistent with the software intended to manage and validate these changes.

- The cable connectors have a ridge on one side (FIGURE 2-8) that indicates proper alignment of the cable.
- The connectors make a distinct clicking sound when fully inserted.

To protect the cables, be sure to:

- Keep dust caps in place whenever cables are not connected.
- Maintain a minimum bend radius of at least 30 millimeter (1.2 inches).

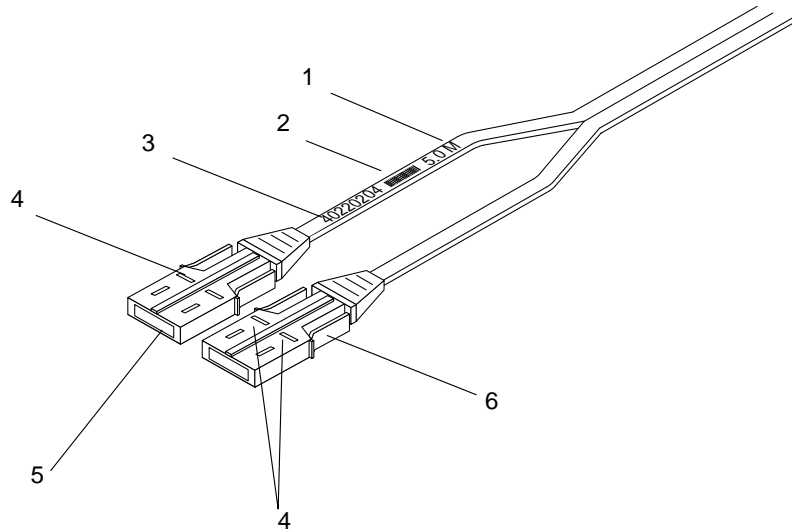

- |  |                       |
|--|-----------------------|
| 1. Cable length                                    | 5. Transmit connector |
| 2. Bar code  | 6. Receive connector  |
| 3. Unique serial number<br>(at both ends of cable) |                       |
| 4. Insertion marks (disappear<br>when inserted)    |                       |

FIGURE 2-8 Sun Fire Link Cable

## 2.5.1 Cabling Sun Fire Link Systems

Cables can be added to and removed from the system while the system is operating.

- **Install cables. (The black connector is receive and the white connector is transmit.) Be sure to follow the cabling patterns you planned for your system in Appendix A of the *Sun Fire Link Hardware Installation Guide*.**

Make sure to insert the cable connector all the way in until you hear a clicking sound.



# Removing and Replacing Components in a Sun Fire 15K/12K System

---

This chapter provides removal and replacement procedures for field-replaceable components (FRUs) on a Sun Fire Link assembly in a Sun Fire 15K/12K system.

To protect both yourself and the equipment, make sure you follow the precautions in Chapter 1.

This chapter contains the following sections:

- Section 3.1, “Handling Boards and Assemblies” on page 3-1
- Section 3.3, “Sun Fire Link Assembly” on page 3-3
- Section 3.4, “Sun Fire Link Optical Modules” on page 3-11

---

## 3.1 Handling Boards and Assemblies



---

**Caution** – The chassis AC power cord must remain connected to ensure a proper ground.

---



---

**Caution** – The system is sensitive to static electricity. To prevent damage to the assembly, connect an antistatic wrist strap between you and the system.

---



---

**Caution** – The Sun Fire Link assembly, its modules, and its cards have surface-mount components that can be broken if you flex the assemblies.

---

To minimize the amount of board flexing, observe the following precautions:

- Hold the board only by the edges near the middle of the board, where the board stiffener is located. Do not hold the board *only* at the ends.
- When removing the board from an antistatic bag, keep the board vertical until you lay it on the Sun ESD mat.
- Do not place the board on a hard surface. Use a cushioned antistatic mat. The board connectors and components have very thin pins that bend easily.
- Be careful of small parts located on the component side of the board.
- Do not use an oscilloscope probe on the components. The soldered pins are easily damaged or shorted by the probe point.
- Transport the board in an antistatic bag.



---

**Caution** – The heatsinks on the assembly can be damaged by incorrect handling. Do not touch the heatsinks while replacing or removing the board. Hold the board only by the edges. If a heatsink is loose or broken, obtain a replacement board.

---



---

**Caution** – The heatsinks on the assembly can be damaged by improper packaging. When storing or shipping the board, ensure that the heatsinks have sufficient protection.

---

---

**Note** – The Sun Fire Link assembly and Sun Fire Link optical modules can be inserted into a powered-on system. A new assembly or optical module will not be recognized by the system until the domain has been re-initialized and rebooted. Refer to the *Sun Management Center 3.0 Software Supplement for Sun Fire Link* for complete procedures for initializing a domain.

---

---

## 3.2 Filler Boards, Filler Panels, and CompactPCI Filler Cards

To prevent the system from overheating, see Section 1.4, “Filler Boards and Filler Panels” on page 1-5 for procedures you must follow when removing the Sun Fire Link assembly from a system.

---

**Caution** – You must install a filler panel which covers only the front of the assembly slot, if the system is to be powered up without the Sun Fire Link assembly installed.

---



---

**Caution** – Make sure all slots in the Sun Fire Link assembly are filled: by cards OR filler boards.

---

## 3.3 Sun Fire Link Assembly

Each Sun Fire Link assembly has:

- Two hot-swappable Sun Fire Link optical module slots
- Two hot-swappable CompactPCI slots that may be used for I/O

The Sun Fire Link assembly (FIGURE 3-3) is based on an hsPCI I/O Assembly for a Sun Fire 15K/12K system.

Sun Fire Link assemblies can be installed in I/O slots 0 through 8 on the front of a Sun Fire 15K/12K chassis (FIGURE 3-1) and in slots 9 through 17 on the rear of a Sun Fire 15K/12K chassis (FIGURE 3-2).

Sun Fire Link assemblies must be installed in consecutive slots, beginning with an even number slot, for example, slots 0 and 1; 2 and 3; 4 and 5; etc.

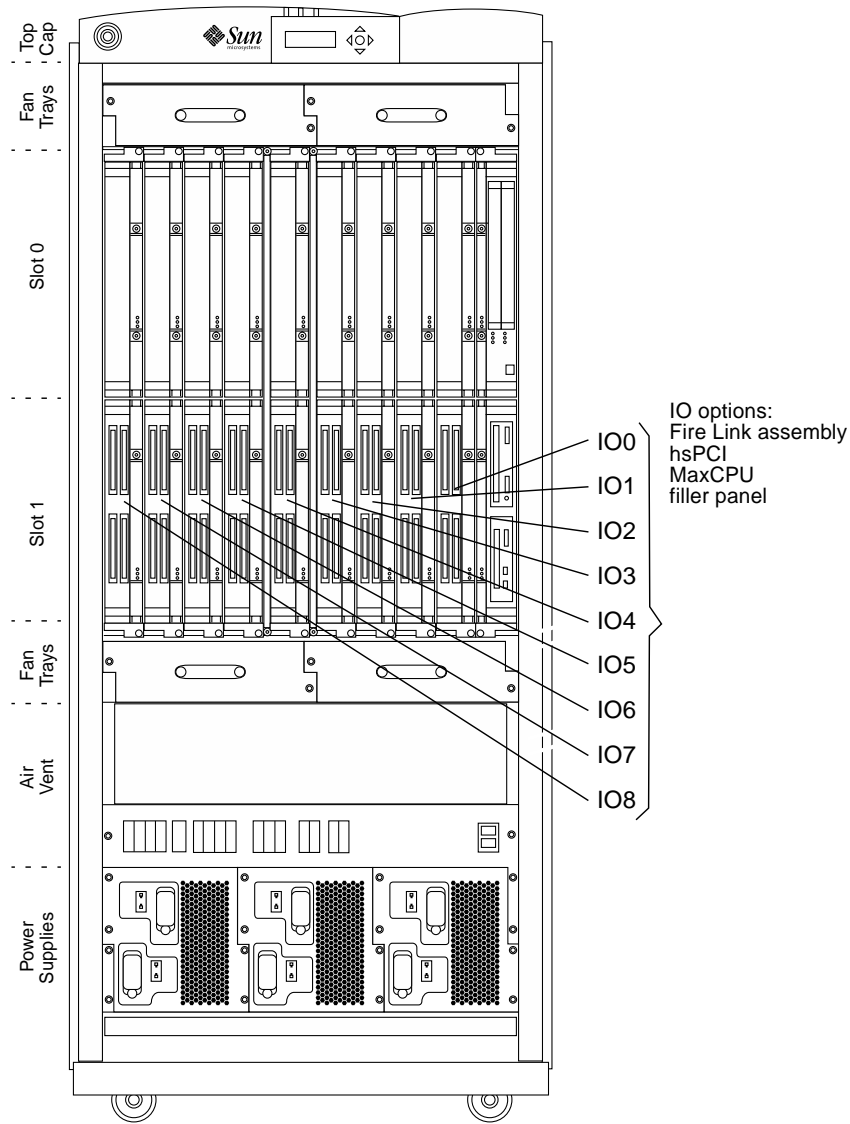

**FIGURE 3-1** Sun Fire Link Assembly Locations—Front (Side 0)

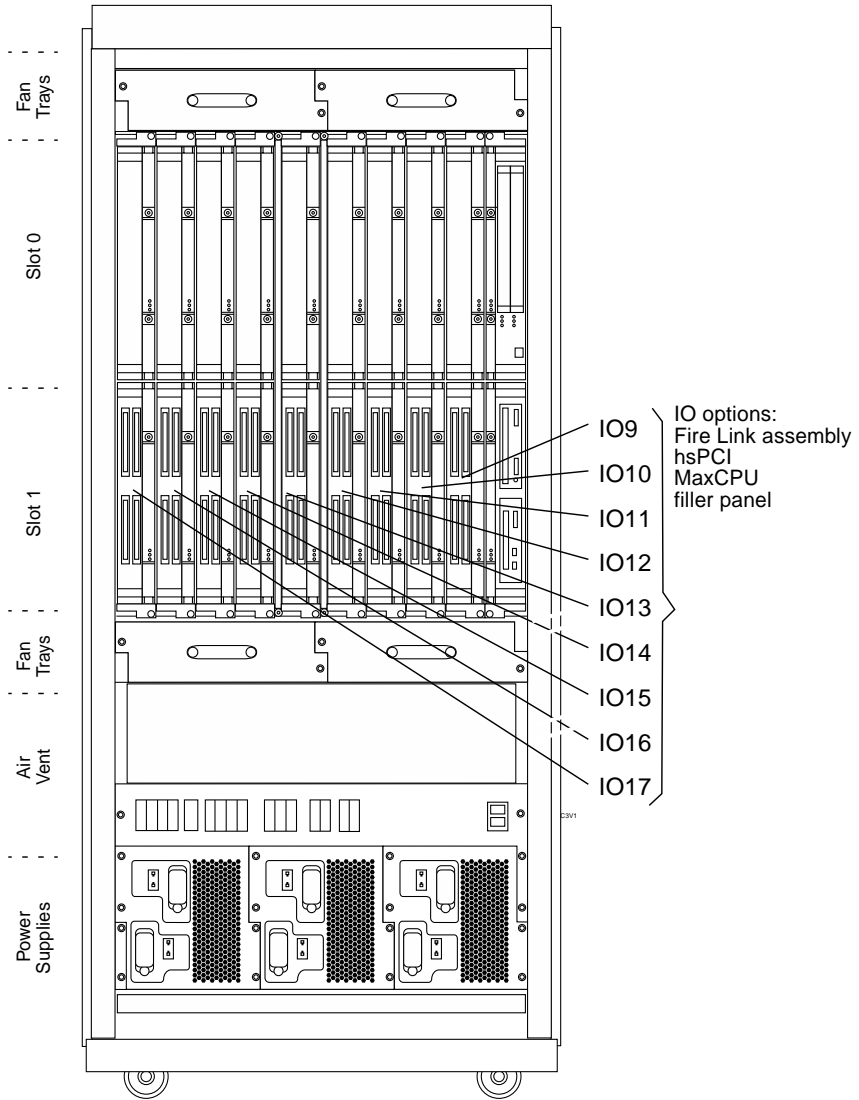

**FIGURE 3-2** Sun Fire Link Assembly Locations—Rear (Side 1)

### 3.3.1 CompactPCI Slots in a Sun Fire Link Assembly

Each Sun Fire Link assembly (FIGURE 3-3) contains four slots. Slot 0 and Slot 3 are standard CompactPCI slots which can be used for other approved CompactPCI functions in a Sun Fire 15K/12K system. Slots LINK 0 and LINK 2 are used only for Sun Fire Link optical modules.

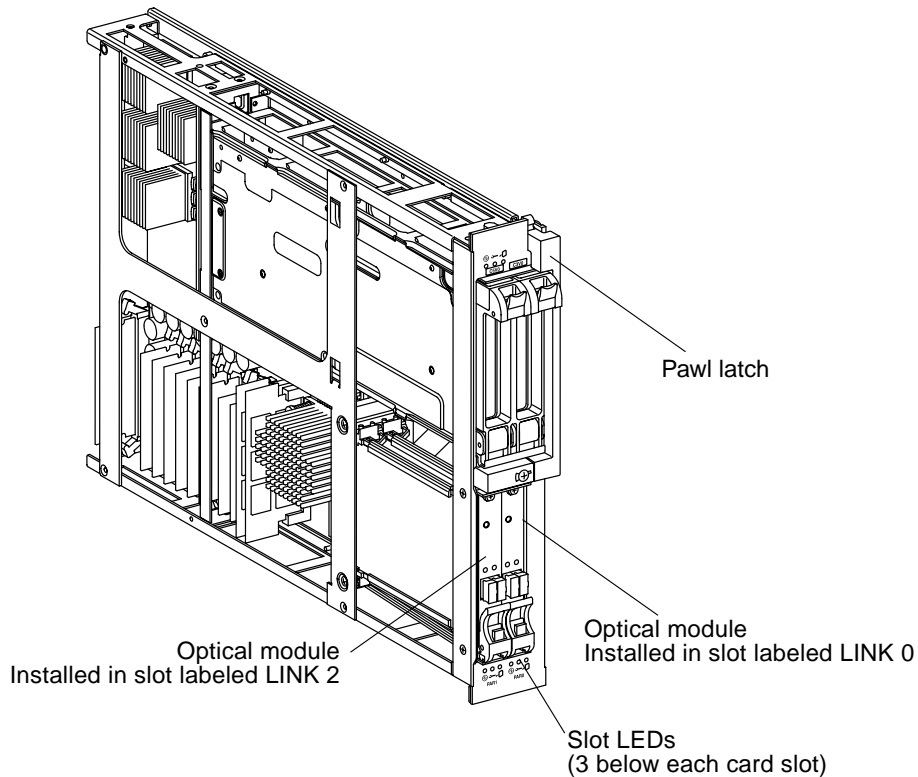



**FIGURE 3-3** Sun Fire Link Assembly for Sun Fire 15K/12K Systems

## 3.3.2 Sun Fire Link Assembly LEDs

Each Sun Fire Link Assembly has three LEDs (*slot LEDs*) that provide power, fault, and removal status. TABLE 3-1 notes the LED functions.

TABLE 3-1 Sun Fire Link Slot LED Functions

LED	On	Off
Power LED (green)	 Power is on; you cannot remove the Sun Fire Link assembly when this LED is on.	Power is off; you can remove the Sun Fire Link assembly when this LED is off.
Fault LED (amber)	 Internal fault	No internal fault
Removal OK LED (amber)	 You can safely remove the Sun Fire Link Assembly under hot-swap conditions.	Do not remove the Sun Fire Link assembly.

## 3.3.3 Sun Fire Link ASIC Port IDs

FIGURE 3-4 and TABLE 3-2 provides Sun Fire Link ASIC port ID numbers for all 18 I/O slots in the Sun Fire 15K/12K system.

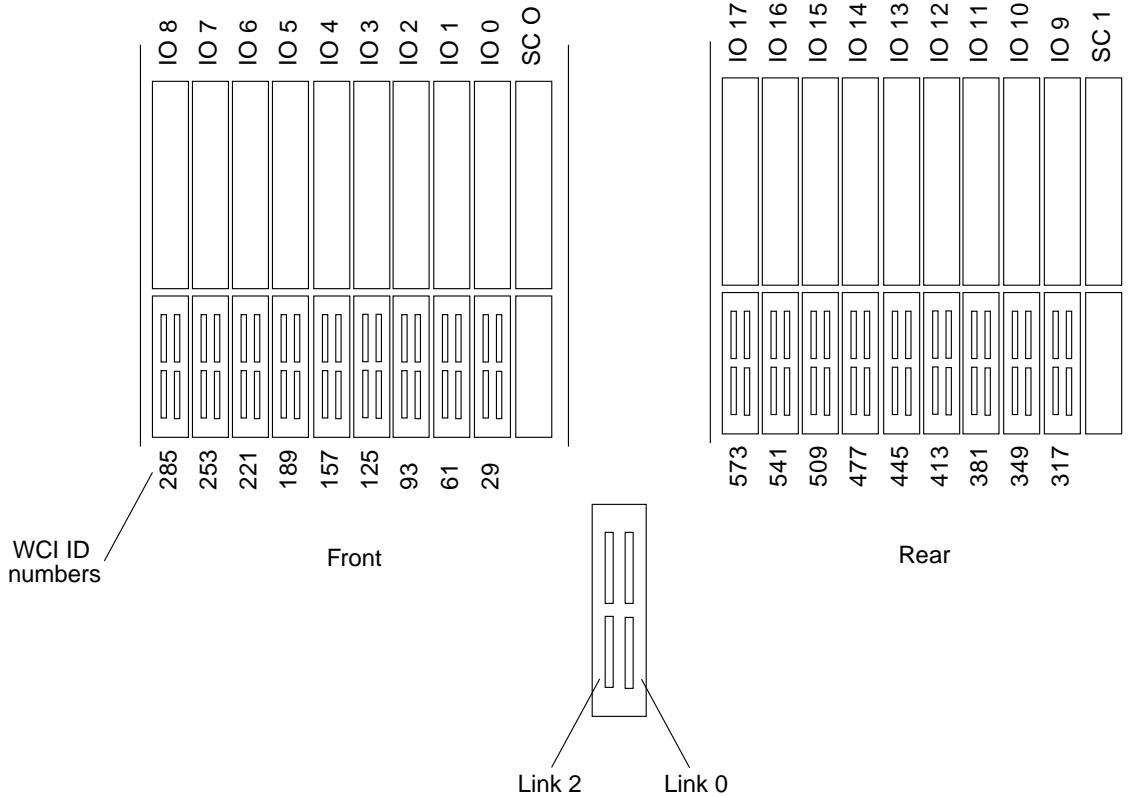

**FIGURE 3-4** Sun Fire Link Assembly Locations and Corresponding ASIC IDs

**TABLE 3-2** Sun Fire Link 15K/12K System Port IDs

Sun Fire 15K/12K I/O Slot	Sun Fire Link ASIC Port ID Number
0	29
1	61
2	93
3	125
4	157
5	189
6	221
7	253

TABLE 3-2 Sun Fire Link 15K/12K System Port IDs (Continued)

Sun Fire 15K/12K I/O Slot	Sun Fire Link ASIC Port ID Number
8	285
9	317
10	349
11	381
12	413
13	445
14	477
15	509
16	541
17	573

## 3.3.4 Removing and Replacing Sun Fire Link Assemblies

---

**Note** – Be sure you are properly grounded before you begin the hardware removal and installation of the assembly.

---

There are four ground points on the system cabinet, two at the front top left and top right, and two at the rear top left and top right.



---

**Caution** – After the assembly is removed, carry the assembly to a work area holding it vertically by the front handle with the connector downward. Lift the assembly and place the other hand under the bottom, or back, of the assembly, placing the bottom, or back, on an ESD-protected surface. *Never* place the weight of the assembly on its connector as it is easily damaged.

---

### 3.3.4.1 Removing a Sun Fire Link Assembly

1. Refer to the procedure for powering off an hsPCI assembly in the *Sun Fire 15K/12K System Service Manual* for the procedure to power off a Sun Fire Link assembly.
2. Open the Sun Fire 15K/12K system cabinet access doors, front (side 0) or rear (side 1).



---

**Caution** – Before removing a assembly from the system, the green activation LED must be off and the amber removal OK LED must be on.

---

3. Label and remove any Sun Fire Link optical cables from the assembly.
4. Insert a Phillips No. 1 screwdriver in the pawl latches (FIGURE 3-3), turning counter clockwise to release the lever and lift the carrier insert-eject lever.

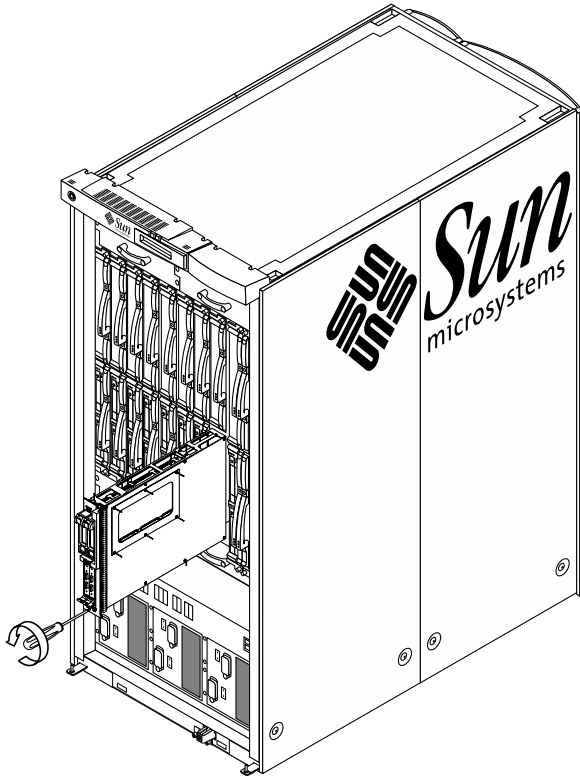

FIGURE 3-5 Replacing a Sun Fire Link Assembly in a Sun Fire 15K/12K System

5. Use the front handle to extract the assembly, supporting the bottom with the other hand, and place it on a flat, sturdy, ESD-protected surface with the component side up.

### 3.3.4.2 Installing a Sun Fire Link Assembly

1. Firmly grasp the assembly, supporting the bottom with the other hand, and position it onto the carrier rail.



2. With the insert-eject lever extended, slide the assembly into the slot until it begins to connect with the expander connector.
3. Apply firm pressure to the face plate to properly seat the assembly with the expander connector.
4. Use the insert-eject lever to fully seat and automatically lock the assembly into position.

---

**Note** – Failure of the service LED to change from on to off within 60 seconds after insertion indicates a power-status control fault.

---

5. Install all Sun Fire Link optical cables.

## 3.4 Sun Fire Link Optical Modules

Optical modules must be installed in slots Link 0 and Link 2.

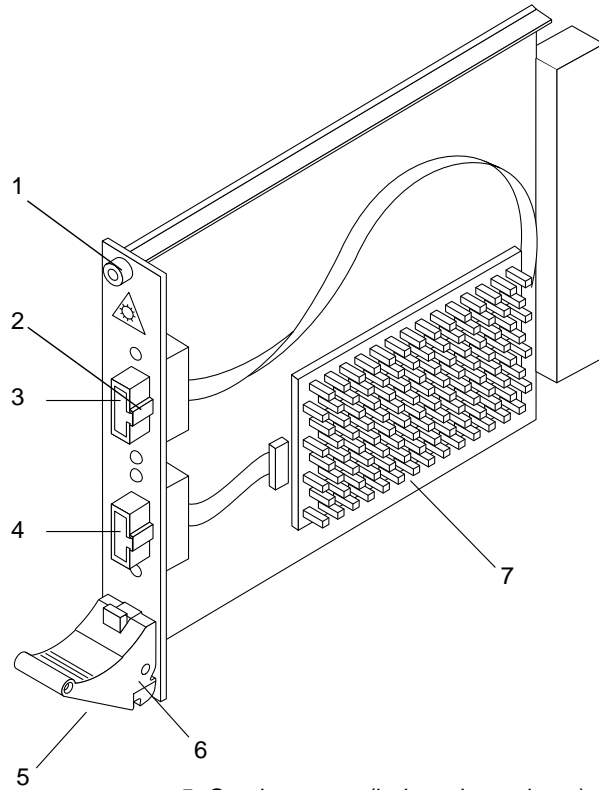



- 1. Captive screw
- 2. Alignment ridge
- 3. Receive connector
- 4. Transmit connector
- 5. Captive screw (below ejector lever)
- 6. Ejector Lever
- 7. Heat Sink

**FIGURE 3-6** Sun Fire Link Optical Module

## 3.4.1 Sun Fire Link Optical Module LEDs

There are three LEDs (*slot LEDs*) for each card slot on the Sun Fire Link assembly. TABLE 3-3 notes the LED function.

TABLE 3-3 Sun Fire Link Slot LED Functions

LED		On	Off
Power LED (green)		Power is on; you cannot remove the optical module when this LED is on.	Power is off; you can remove the optical module when this LED is off.
Fault LED (amber)		Internal fault	No internal fault
Removal OK LED (amber)		You can safely remove the optical module under hot-swap conditions.	Do not remove the optical module.

Besides the LEDs that are located on the assembly, each optical link module has three LEDs, *card LEDs*, (FIGURE 3-7 and TABLE 3-4) on the module itself. A single green LED indicates whether or not power is applied; paired green and amber LEDs convey link status and configuration, TABLE 3-4.

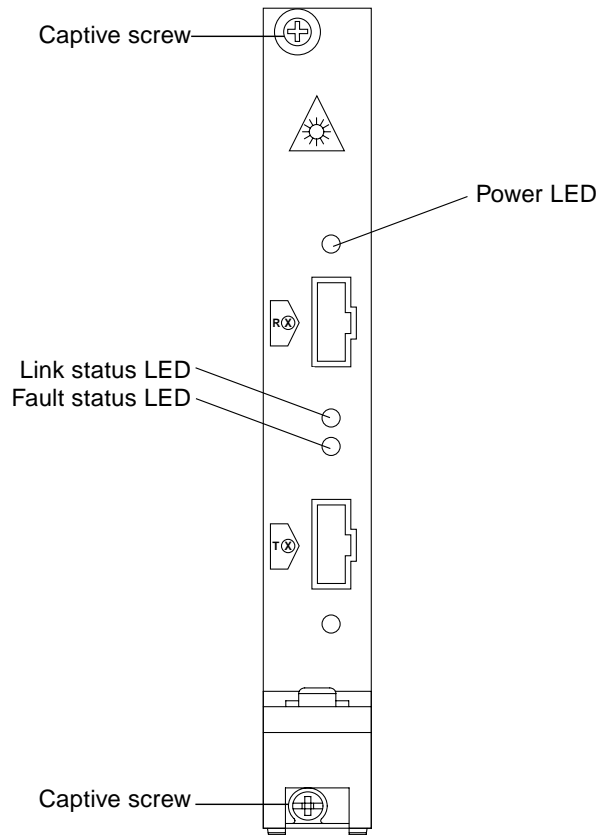

**FIGURE 3-7** Card LEDs on the Optical Module

**TABLE 3-4** Card LEDs on the Optical Module

<b>Green</b>	<b>Amber</b>	<b>Meaning</b>
OFF	OFF	No External Link detected. No valid Re Clock detected
ON	OFF	Link operational: Valid Rx clock received. Remote ID validated.
ON	ON	Degraded link detected: This combination indicates that an error threshold has been exceeded. The link is still operational but performance may be degraded.
BLINKING	OFF	Link is in the process of moving to the operational state.

## 3.4.2 Removing and Replacing a Sun Fire Link Optical Module

If there is an optical module installed in the slots labeled LINK 0 or LINK 2, you must remove that module before installing the new Sun Fire Link optical module.

### 3.4.2.1 Removing a Sun Fire Link Optical Module

1. **Ensure that either a replacement module or filler board is immediately available.**
2. **Attach a wrist strap or foot strap. Connect the ESD strap to the system. Place a grounded ESD mat close to the system.**
3. **Disconnect and label any cables from the optical module that are being removed.**
4. **Loosen the two captive screws, one at each end of the optical module.**
5. **Press the lever outward to eject the optical module.**
6. **Slide the card out of the slot.**

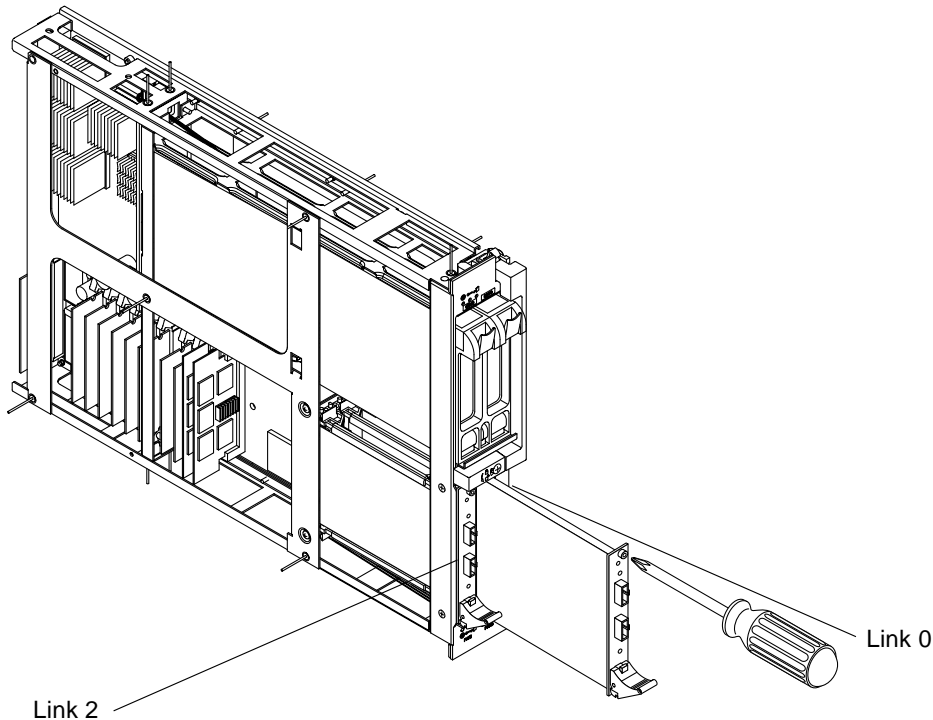

**FIGURE 3-8** Replacing an Optical Module in a Sun Fire Link Assembly for Sun Fire 15K/12K Systems

- 7. Install a filler card in the empty slot if you will not be installing another optical module within one minute.**

---

**Note** – You must have either a filler card or an optical module installed in the two optical module slots and a filler card or a CompactPCI I/O card in the upper two slots.

---

### 3.4.2.2 Installing a Sun Fire Link Optical Module

- 1. Attach a wrist strap or foot strap. Connect the ESD strap to the system.**
- 2. If installed, remove the filler panel.**
- 3. Press the ejector lever down on the optical module.**

4. **Hold the optical module by the two side edges or the front panel and slide it into the slot between the two guides (FIGURE 3-8).**

The cutouts in the handle of the optical module must align with the square cutouts on the Sun Fire Link assembly.

5. **Push on the front panel to completely seat the optical module in the assembly.**
6. **Push the ejector lever in to lock the lever. You should feel it click.**
7. **Tighten the two captive screws, one at each end of the optical module.**

---

## 3.5 Sun Fire Link Cables

The Sun Fire Link cables have the following features:

- Cables are available in 5-, 12-, and 20-meter lengths.
- Each cable has two connectors at each end (FIGURE 3-9).
  - The transmit connector (Tx) is white.
  - The receive connector (Rx) is black.
- Each cable is labeled with a serial number that aids in cable route tracing (FIGURE 3-9).
- Cable changes can be made while the system is operational. Changes should be made consistent with the software intended to manage and validate these changes.
- The cable connectors have a ridge on one side (FIGURE 3-9) that indicates proper alignment of the cable.
- The connectors make a distinct clicking sound when fully inserted.

To protect the cables, be sure to:

- Keep dust caps in place whenever cables are not connected.
- Maintain a minimum bend radius of at least 30 millimeter (1.2 inches).

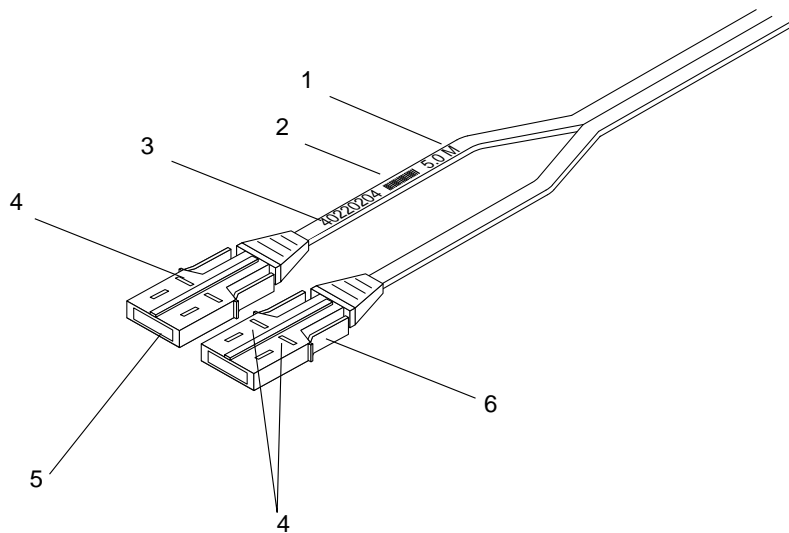

- |  |                       |
|--|-----------------------|
| 1. Cable length                                    | 5. Transmit connector |
| 2. Bar code  | 6. Receive connector  |
| 3. Unique serial number<br>(at both ends of cable) |                       |
| 4. Insertion marks (disappear<br>when inserted)    |                       |

FIGURE 3-9 Sun Fire Link Cable

### 3.5.0.1 Cabling Sun Fire Link Systems

Cables can be added to and removed from the system while the system is operation.

- **Install cables. (The black connector is receive and the white connector is transmit.) Be sure to follow the cabling patterns in Appendix A of the *Sun Fire Link Hardware Installation Guide*.**

Make sure to insert the cable connector all the way in until you hear a clicking sound.



# Illustrated Parts Breakdown

---

The illustrations and tables in this appendix describe the replacement parts for Sun Fire Link Interconnect.

---

## A.1 Finding Part Numbers

Part numbers in this section may differ from those found in your system. Before ordering replacement parts, find the label on the part to be replaced and place your order using that number. Be sure to use the right part number (for the entire assembly instead of the individual components as shown in TABLE A-1.)

---

## A.2 List of Replacement Parts

TABLE A-1 lists the replaceable components and their part numbers

**TABLE A-1** List of Replacable Components

Description	Part Number
Sun Fire Link Assembly for Sun Fire 6800 systems	F501-6094-04
Sun Fire Link Assembly for Sun Fire 15K/12K systems	F501-6303-07
Sun Fire Link Optical Module (Paroli)	F375-0093-03
Sun Fire Link optical cable, 5 meter	F537-1022-02
Sun Fire Link optical cable 12 meter	F537-1023-02
Sun Fire Link optical cable 20 meter	F537-1024-02

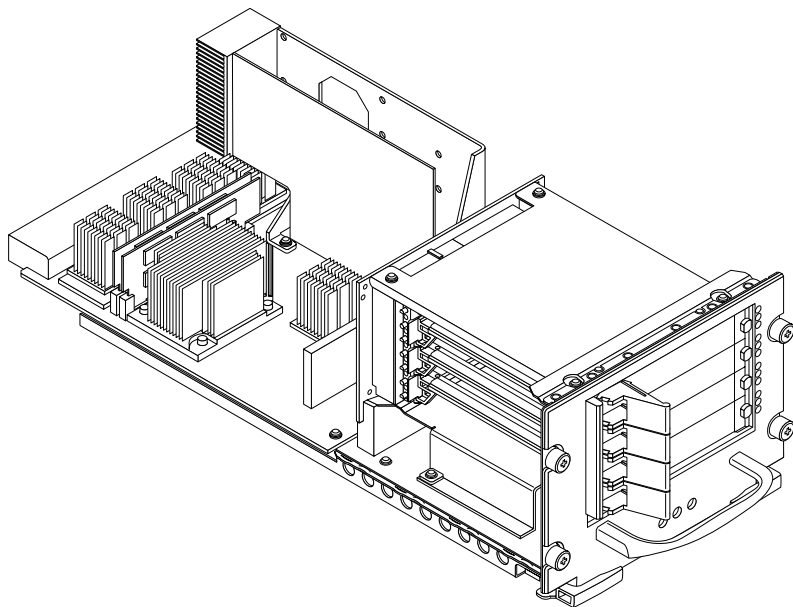

**FIGURE A-1** Sun Fire Link Assembly for Sun Fire 6800 Systems (F501-6094-04)

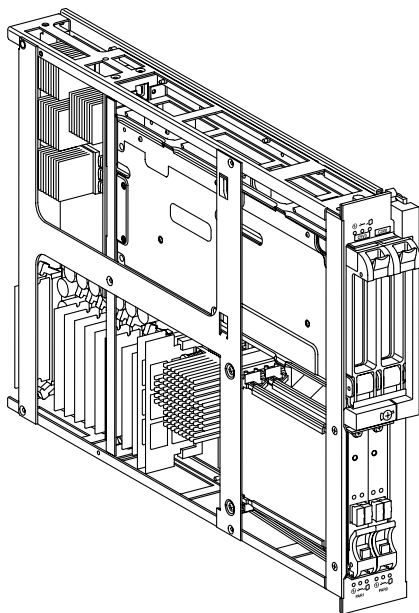

**FIGURE A-2** Sun Fire Link Assembly for Sun Fire 15K/12K Systems (F501-6303-07)

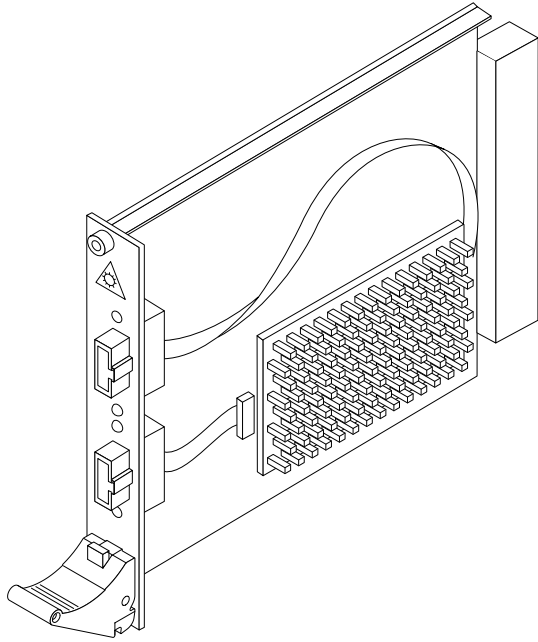

**FIGURE A-3** Sun Fire Link Optical Module (Paroli) (F375-0093-03)

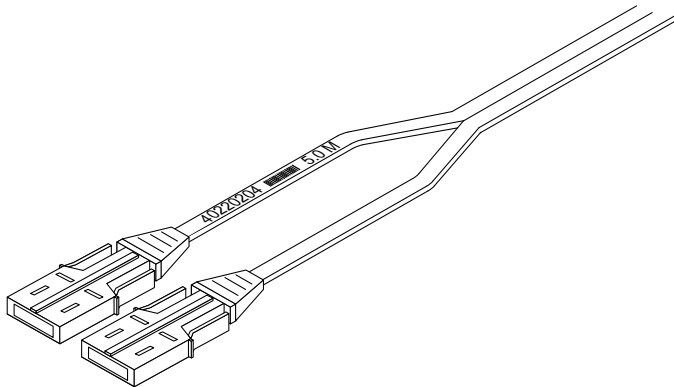

**FIGURE A-4** Sun Fire Link Optical Cable (F537-1022-02, F537-1023-02, and F537-1024-02)



# Regulatory Compliance Statements

---

Your Sun product is marked to indicate its compliance class:

- Federal Communications Commission (FCC) — USA
- Industry Canada Equipment Standard for Digital Equipment (ICES-003) - Canada
- Voluntary Control Council for Interference (VCCI) — Japan
- Bureau of Standards Metrology and Inspection (BSMI) — Taiwan

Please read the appropriate section that corresponds to the marking on your Sun product before attempting to install the product.

---

## B.1 FCC Class A Notice

This device complies with Part 15 of the FCC Rules. Operation is subject to the following two conditions:

1. This device may not cause harmful interference.
2. This device must accept any interference received, including interference that may cause undesired operation.

---

**Note** – This equipment has been tested and found to comply with the limits for a Class A digital device, pursuant to Part 15 of the FCC Rules. These limits are designed to provide reasonable protection against harmful interference when the equipment is operated in a commercial environment. This equipment generates, uses, and can radiate radio frequency energy, and if it is not installed and used in accordance with the instruction manual, it may cause harmful interference to radio communications. Operation of this equipment in a residential area is likely to cause harmful interference, in which case the user will be required to correct the interference at his own expense.

---

**Shielded Cables:** Connections between the workstation and peripherals must be made using shielded cables to comply with FCC radio frequency emission limits. Networking connections can be made using unshielded twisted-pair (UTP) cables.

**Modifications:** Any modifications made to this device that are not approved by Sun Microsystems, Inc. may void the authority granted to the user by the FCC to operate this equipment.

---

## B.2 FCC Class B Notice

This device complies with Part 15 of the FCC Rules. Operation is subject to the following two conditions:

1. This device may not cause harmful interference.
2. This device must accept any interference received, including interference that may cause undesired operation.

---

**Note** – This equipment has been tested and found to comply with the limits for a Class B digital device, pursuant to Part 15 of the FCC Rules. These limits are designed to provide reasonable protection against harmful interference in a residential installation. This equipment generates, uses and can radiate radio frequency energy and, if not installed and used in accordance with the instructions, may cause harmful interference to radio communications. However, there is no guarantee that interference will not occur in a particular installation. If this equipment does cause harmful interference to radio or television reception, which can be determined by turning the equipment off and on, the user is encouraged to try to correct the interference by one or more of the following measures:

---

- Reorient or relocate the receiving antenna.
- Increase the separation between the equipment and receiver.
- Connect the equipment into an outlet on a circuit different from that to which the receiver is connected.
- Consult the dealer or an experienced radio/television technician for help.

**Shielded Cables:** Connections between the workstation and peripherals must be made using shielded cables in order to maintain compliance with FCC radio frequency emission limits. Networking connections can be made using unshielded twisted pair (UTP) cables.

**Modifications:** Any modifications made to this device that are not approved by Sun Microsystems, Inc. may void the authority granted to the user by the FCC to operate this equipment.

---

## B.3 ICES-003 Class A Notice - Avis NMB-003, Classe A

This Class A digital apparatus complies with Canadian ICES-003.

Cet appareil numérique de la classe A est conforme à la norme NMB-003 du Canada.

---

## B.4 ICES-003 Class B Notice - Avis NMB-003, Classe B

This Class B digital apparatus complies with Canadian ICES-003.

Cet appareil numérique de la classe B est conforme à la norme NMB-003 du Canada.

### VCCI 基準について

#### クラス A VCCI 基準について

クラス A VCCI の表示があるワークステーションおよびオプション製品は、クラス A 情報技術装置です。これらの製品には、下記の項目が該当します。

この装置は、情報処理装置等電波障害自主規制協議会 (VCCI) の基準に基づくクラス A 情報技術装置です。この装置を家庭環境で使用すると電波妨害を引き起こすことがあります。この場合には使用者が適切な対策を講ずるよう要求されることがあります。

## クラス B VCCI 基準について

クラス B VCCI の表示  があるワークステーションおよびオプション製品は、クラス B 情報技術装置です。これらの製品には、下記の項目が該当します。

この装置は、情報処理装置等電波障害自主規制協議会 (VCCI) の基準に基づくクラス B 情報技術装置です。この装置は、家庭環境で使用することを目的としていますが、この装置がラジオやテレビジョン受信機に近接して使用されると、受信障害を引き起こすことがあります。取扱説明書に従って正しい取り扱いをしてください。

---

## B.5 BSMI Class A Notice

The following statement is applicable to products shipped to Taiwan and marked as Class A on the product compliance label.

警告使用者：

這是甲類的資訊產品，在居住的環境中使用時，可能會造成射頻干擾，在這種情況下，使用者會被要求採取某些適當的對策。



# Safety Agency Compliance Statements

Read this section before beginning any procedure. The following text provides safety precautions to follow when installing a Sun Microsystems product.

## Safety Precautions

For your protection, observe the following safety precautions when setting up your equipment:

- Follow all cautions and instructions marked on the equipment.
- Ensure that the voltage and frequency of your power source match the voltage and frequency inscribed on the equipment's electrical rating label.
- Never push objects of any kind through openings in the equipment. Dangerous voltages may be present. Conductive foreign objects could produce a short circuit that could cause fire, electric shock, or damage to your equipment.

## Symbols

The following symbols may appear in this book:



---

**Caution** – There is risk of personal injury and equipment damage. Follow the instructions.

---



---

**Caution** – Hot surface. Avoid contact. Surfaces are hot and may cause personal injury if touched.

---



---

**Caution** – Hazardous voltages are present. To reduce the risk of electric shock and danger to personal health, follow the instructions.

---



---

**On** – Applies AC power to the system.

---

Depending on the type of power switch your device has, one of the following symbols may be used:



---

**Off** - Removes AC power from the system.

---



---

**Standby** – The On/Standby switch is in the standby position.

---

## Modifications to Equipment

Do not make mechanical or electrical modifications to the equipment. Sun Microsystems is not responsible for regulatory compliance of a modified Sun product.

## Placement of a Sun Product



---

**Caution** – Do not block or cover the openings of your Sun product. Never place a Sun product near a radiator or heat register. Failure to follow these guidelines can cause overheating and affect the reliability of your Sun product.

---



---

**Caution** – Noise level during normal operating condition is below 70Db(A). Noise level during over temperature condition may be above 70Db(A). Limit exposure during this temporary condition.

---

## SELV Compliance

Safety status of I/O connections comply to SELV requirements.

## Power Cord Connection



---

**Caution** – Sun products are designed to work with a line-to-neutral or line-to-line connection. To reduce the risk of electric shock, do not plug Sun products into any other type of power system. Contact your facilities manager or a qualified electrician if you are not sure what type of power is supplied to your building.

---



---

**Caution** – Not all power cords have the same current ratings. Household extension cords do not have overload protection and are not meant for use with computer systems. Do not use household extension cords with your Sun product.

---



---

**Caution** – Your Sun product is shipped with a grounding type (three-wire) power cord. To reduce the risk of electric shock, always plug the cord into a grounded power outlet.

---

The following caution applies only to devices with a Standby power switch:



---

**Caution** – The power switch of this product functions as a standby type device only. The power cord serves as the primary disconnect device for the system. Be sure to plug the power cord into a grounded power outlet that is nearby the system and is readily accessible. Do not connect the power cord when the power supply has been removed from the system chassis.

---

## Lithium Battery



---

**Caution** – On Sun SC CPU boards, there is a lithium battery molded into the real-time clock, SGS No. MK48T59Y, MK48TXXB-XX, MK48T18-XXXPCZ, M48T59W-XXXPCZ, or MK48T08. Batteries are not customer replaceable parts. They may explode if mishandled. Do not dispose of the battery in fire. Do not disassemble it or attempt to recharge it.

---

## Laser Compliance Notice

Sun products that use laser technology comply with Class 1 laser requirements.

Class 1 Laser Product  
Luokan 1 Laserlaite  
Klasse 1 Laser Apparat  
Laser Klasse 1

## CD ROM/DVD ROM



---

**Caution** – Use of controls, adjustments, or the performance of procedures other than those specified herein may result in hazardous radiation exposure.

---

## Einhaltung sicherheitsbehördlicher Vorschriften

Auf dieser Seite werden Sicherheitsrichtlinien beschrieben, die bei der Installation von Sun-Produkten zu beachten sind.

### Sicherheitsvorkehrungen

Treffen Sie zu Ihrem eigenen Schutz die folgenden Sicherheitsvorkehrungen, wenn Sie Ihr Gerät installieren:

- Beachten Sie alle auf den Geräten angebrachten Warnhinweise und Anweisungen.
- Vergewissern Sie sich, daß Spannung und Frequenz Ihrer Stromquelle mit der Spannung und Frequenz übereinstimmen, die auf dem Etikett mit den elektrischen Nennwerten des Geräts angegeben sind.
- Stecken Sie auf keinen Fall irgendwelche Gegenstände in Öffnungen in den Geräten. Leitfähige Gegenstände könnten aufgrund der möglicherweise vorliegenden gefährlichen Spannungen einen Kurzschluß verursachen, der einen Brand, Stromschlag oder Geräteschaden herbeiführen kann.

### Symbole

Die Symbole in diesem Handbuch haben folgende Bedeutung:



---

**Achtung** – Gefahr von Verletzung und Geräteschaden. Befolgen Sie die Anweisungen.

---



---

**Achtung** – Hohe Temperatur. Nicht berühren, da Verletzungsgefahr durch heiße Oberfläche besteht.

---



---

**Achtung** – Gefährliche Spannungen. Anweisungen befolgen, um Stromschläge und Verletzungen zu vermeiden.

---

---

**Ein** – Setzt das System unter Wechselstrom.

---

Je nach Netzschaltertyp an Ihrem Gerät kann eines der folgenden Symbole benutzt werden:



---

**Aus** – Unterbricht die Wechselstromzufuhr zum Gerät.

---



---

**Wartezustand** (Stand-by-Position) - Der Ein-/Wartezustand-Schalter steht auf Wartezustand. Änderungen an Sun-Geräten.

---

Nehmen Sie keine mechanischen oder elektrischen Änderungen an den Geräten vor. Sun Microsystems, übernimmt bei einem Sun-Produkt, das geändert wurde, keine Verantwortung für die Einhaltung behördlicher Vorschriften

### Aufstellung von Sun-Geräten



---

**Achtung** – Um den zuverlässigen Betrieb Ihres Sun-Geräts zu gewährleisten und es vor Überhitzung zu schützen, dürfen die Öffnungen im Gerät nicht blockiert oder verdeckt werden. Sun-Produkte sollten niemals in der Nähe von Heizkörpern oder Heizluftklappen aufgestellt werden.

---



---

**Achtung** – Unter normalen Betriebsbedingungen liegt der Geräuschpegel unter 70 Db(A). Bei erhöhten Temperaturen kann der Geräuschpegel bei über 70 Db(A) liegen. Minimieren Sie eine Überhitzung des Gerätes.

---

### Einhaltung der SELV-Richtlinien

Die Sicherung der I/O-Verbindungen entspricht den Anforderungen der SELV-Spezifikation.

## Anschluß des Netzkabels



---

**Achtung** – Sun-Produkte sind für die Verwendung mit einer Leiter-zu-Neutral- oder einer Leiter-zu-Leiter-Verbindung vorgesehen. Um die Stromschlaggefahr zu reduzieren, schließen Sie Sun-Produkte nicht an andere Stromquellen an. Ihr Betriebsleiter oder ein qualifizierter Elektriker kann Ihnen die Daten zur Stromversorgung in Ihrem Gebäude geben.

---



---

**Achtung** – Nicht alle Netzkabel haben die gleichen Nennwerte. Herkömmliche, im Haushalt verwendete Verlängerungskabel besitzen keinen Überlastungsschutz und sind daher für Computersysteme nicht geeignet.

---



---

**Achtung** – Ihr Sun-Gerät wird mit einem dreiadrigen Netzkabel für geerdete Netzsteckdosen geliefert. Um die Gefahr eines Stromschlags zu reduzieren, schließen Sie das Kabel nur an eine fachgerecht verlegte, geerdete Steckdose an.

---

Die folgende Warnung gilt nur für Geräte mit Wartezustand-Netzschalter:



---

**Achtung** – Der Ein/Aus-Schalter dieses Geräts schaltet nur auf Wartezustand (Stand-By-Modus). Um die Stromzufuhr zum Gerät vollständig zu unterbrechen, müssen Sie das Netzkabel von der Steckdose abziehen. Schließen Sie den Stecker des Netzkabels an eine in der Nähe befindliche, frei zugängliche, geerdete Netzsteckdose an. Schließen Sie das Netzkabel nicht an, wenn das Netzteil aus der Systemeinheit entfernt wurde.

---

## Lithiumbatterie



---

**Achtung** – SC CPU-Karten von Sun verfügen über eine Echtzeituhr mit integrierter Lithiumbatterie (Teile-Nr. MK48T59Y, MK48TXXB-XX, MK48T18-XXXPCZ, M48T59W-XXXPCZ, oder MK48T08). Diese Batterie darf nur von einem qualifizierten Servicetechniker ausgewechselt werden, da sie bei falscher Handhabung explodieren kann. Werfen Sie die Batterie nicht ins Feuer. Versuchen Sie auf keinen Fall, die Batterie auszubauen oder wiederaufzuladen.

---

## Einhaltung der Richtlinien für Laser

Sun-Produkte, die mit Laser-Technologie arbeiten, entsprechen den Anforderungen der Laser Klasse 1.

Class 1 Laser Product  
Luokan 1 Laserlaite  
Klasse 1 Laser Apparat  
Laser Klasse 1

## CD ROM/DVD ROM



---

**Warnung** – Die Verwendung von anderen Steuerungen und Einstellungen oder die Durchführung von Prozeduren, die von den hier beschriebenen abweichen, können gefährliche Strahlungen zur Folge haben.

---

## Conformité aux normes de sécurité

Ce texte traite des mesures de sécurité qu'il convient de prendre pour l'installation d'un produit Sun Microsystems.

### Mesures de sécurité

Pour votre protection, veuillez prendre les précautions suivantes pendant l'installation du matériel :

- Suivre tous les avertissements et toutes les instructions inscrites sur le matériel.
- Vérifier que la tension et la fréquence de la source d'alimentation électrique correspondent à la tension et à la fréquence indiquées sur l'étiquette de classification de l'appareil.
- Ne jamais introduire d'objets quels qu'ils soient dans une des ouvertures de l'appareil. Vous pourriez vous trouver en présence de hautes tensions dangereuses. Tout objet conducteur introduit de la sorte pourrait produire un court-circuit qui entraînerait des flammes, des risques d'électrocution ou des dégâts matériels.

### Symboles

Vous trouverez ci-dessous la signification des différents symboles utilisés :



**Attention:** – risques de blessures corporelles et de dégâts matériels. Veuillez suivre les instructions.



**Attention:** – surface à température élevée. Évitez le contact. La température des surfaces est élevée et leur contact peut provoquer des blessures corporelles.



**Attention:** – présence de tensions dangereuses. Pour éviter les risques d'électrocution et de danger pour la santé physique, veuillez suivre les instructions.

**MARCHE** – Votre système est sous tension (courant alternatif).

Un des symboles suivants sera peut-être utilisé en fonction du type d'interrupteur de votre système:



**ARRET** - Votre système est hors tension (courant alternatif).



**VEILLEUSE** – L'interrupteur Marche/Veilleuse est en position « Veilleuse ».

### Modification du matériel

Ne pas apporter de modification mécanique ou électrique au matériel. Sun Microsystems n'est pas responsable de la conformité réglementaire d'un produit Sun qui a été modifié.

### Positionnement d'un produit Sun



**Attention:** – pour assurer le bon fonctionnement de votre produit Sun et pour l'empêcher de surchauffer, il convient de ne pas obstruer ni recouvrir les ouvertures prévues dans l'appareil. Un produit Sun ne doit jamais être placé à proximité d'un radiateur ou d'une source de chaleur.



**Attention:** – Pendant le fonctionnement normal, le niveau de bruit est inférieur à 70 Db (A). Pendant l'utilisation à des températures élevées, il peut être supérieur à 70 Db (A). Limitez l'utilisation pendant ces conditions temporaires.

### Conformité SELV

Sécurité : les raccordements E/S sont conformes aux normes SELV.

## Connexion du cordon d'alimentation.



**Attention:** – Les produits Sun sont conçus pour fonctionner avec une connexion ligne à neutre ou ligne à ligne. Pour écarter les risques d'électrocution, ne pas brancher de produit Sun dans un autre type d'alimentation secteur. En cas de doute quant au type d'alimentation électrique du local, veuillez vous adresser au directeur de l'exploitation ou à un électricien qualifié.



**Attention:** – tous les cordons d'alimentation n'ont pas forcément la même puissance nominale en matière de courant. Les rallonges d'usage domestique n'offrent pas de protection contre les surcharges et ne sont pas prévues pour les systèmes d'ordinateurs. Ne pas utiliser de rallonge d'usage domestique avec votre produit Sun.



**Attention:** – votre produit Sun a été livré équipé d'un cordon d'alimentation à trois fils (avec prise de terre). Pour écarter tout risque d'électrocution, branchez toujours ce cordon dans une prise mise à la terre.

L'avertissement suivant s'applique uniquement aux systèmes équipés d'un interrupteur VEILLEUSE:



**Attention:** – le commutateur d'alimentation de ce produit fonctionne comme un dispositif de mise en veille uniquement. C'est la prise d'alimentation qui sert à mettre le produit hors tension. Veuillez donc à installer le produit à proximité d'une prise murale facilement accessible. Ne connectez pas la prise d'alimentation lorsque le châssis du système n'est plus alimenté.

## Batterie au lithium



**Attention:** – sur les cartes SC CPU Sun, une batterie au lithium (référence MK48T59Y, MK48TXXB-XX, MK48T18-XXXPCZ, M48T59W-XXXPCZ, ou MK48T08.) a été moulée dans l'horloge temps réel SGS. Les batteries ne sont pas des pièces remplaçables par le client. Elles risquent d'exploser en cas de mauvais traitement. Ne pas jeter la batterie au feu. Ne pas la démonter ni tenter de la recharger.

## Conformité aux certifications Laser

Les produits Sun qui font appel aux technologies lasers sont conformes aux normes de la classe 1 en la matière.

Class 1 Laser Product  
Luokan 1 Laserlaitte  
Klasse 1 Laser Apparat  
Laser Klasse 1

## CD ROM/DVD ROM



**Attention:** – L'utilisation de contrôles, de réglages ou de performances de procédures autre que celle spécifiée dans le présent document peut provoquer une exposition à des radiations dangereuses.

## Normativas de seguridad

El siguiente texto incluye las medidas de seguridad que se deben seguir cuando se instale algún producto de Sun Microsystems.

### Precauciones de seguridad

Para su protección observe las siguientes medidas de seguridad cuando manipule su equipo:

- Siga todas las avisos e instrucciones marcados en el equipo.
- Asegúrese de que el voltaje y la frecuencia de la red eléctrica concuerdan con las descritas en las etiquetas de especificaciones eléctricas del equipo.
- No introduzca nunca objetos de ningún tipo a través de los orificios del equipo. Pueden haber voltajes peligrosos. Los objetos extraños conductores de la electricidad pueden producir cortocircuitos que provoquen un incendio, descargas eléctricas o daños en el equipo.

### Símbolos

En este libro aparecen los siguientes símbolos:



**Precaución** – Existe el riesgo de lesiones personales y daños al equipo. Siga las instrucciones.



**Precaución** – Superficie caliente. Evite el contacto. Las superficies están calientes y pueden causar daños personales si se tocan.



**Precaución** – Voltaje peligroso presente. Para reducir el riesgo de descarga y daños para la salud siga las instrucciones.



**Encendido** – Aplica la alimentación de CA al sistema.

Según el tipo de interruptor de encendido que su equipo tenga, es posible que se utilice uno de los siguientes símbolos:



**Apagado** - Elimina la alimentación de CA del sistema.



**En espera** – El interruptor de Encendido/En espera se ha colocado en la posición de En espera.

### Modificaciones en el equipo

No realice modificaciones de tipo mecánico o eléctrico en el equipo. Sun Microsystems no se hace responsable del cumplimiento de las normativas de seguridad en los equipos Sun modificados.

### Ubicación de un producto Sun



**Precaución** – Para asegurar la fiabilidad de funcionamiento de su producto Sun y para protegerlo de sobrecalentamientos no deben obstruirse o taparse las rejillas del equipo. Los productos Sun nunca deben situarse cerca de radiadores o de fuentes de calor.



**Precaución** – El nivel de ruido en circunstancias normales de funcionamiento está por debajo de 70 Db (A). El nivel de ruido en circunstancias de temperatura excesiva podría estar por encima de 70 Db (A). En dichas circunstancias temporales limite la exposición.

### Cumplimiento de la normativa SELV

El estado de la seguridad de las conexiones de entrada/salida cumple los requisitos de la normativa SELV.

## Conexión del cable de alimentación eléctrica



**Precaución** – Los productos Sun están diseñados para funcionar con una conexión línea a neutra o línea a línea. Para reducir el riesgo de descarga eléctrica, no conecte los productos Sun a otro tipo de sistema de alimentación eléctrica. Póngase en contacto con el responsable de mantenimiento o con un electricista cualificado si no está seguro del sistema de alimentación eléctrica del que se dispone en su edificio.



**Precaución** – No todos los cables de alimentación eléctrica tienen la misma capacidad. Los cables de tipo doméstico no están provistos de protecciones contra sobrecargas y por tanto no son apropiados para su uso con computadores. No utilice alargadores de tipo doméstico para conectar sus productos Sun.



**Precaución** – Con el producto Sun se proporciona un cable de alimentación con toma de tierra. Para reducir el riesgo de descargas eléctricas conéctelo siempre a un enchufe con toma de tierra.

La siguiente advertencia se aplica solamente a equipos con un interruptor de encendido que tenga una posición "En espera":



**Precaución** – El interruptor de encendido de este producto funciona exclusivamente como un dispositivo de puesta en espera. El enchufe de la fuente de alimentación está diseñado para ser el elemento primario de desconexión del equipo. El equipo debe instalarse cerca del enchufe de forma que este último pueda ser fácil y rápidamente accesible. No conecte el cable de alimentación cuando se ha retirado la fuente de alimentación del chasis del sistema.

## Batería de litio



**Precaución** – En las placas de SC CPU Sun hay una batería de litio insertada en el reloj de tiempo real, tipo SGS Núm. MK48T59Y, MK48TXXB-XX, MK48T18-XXXPCZ, M48T59W-XXXPCZ, o MK48T08. Las baterías no son elementos reemplazables por el propio cliente. Pueden explotar si se manipulan de forma errónea. No arroje las baterías al fuego. No las abra o intente recargarlas.

## Aviso de cumplimiento con requisitos de láser

Los productos Sun que utilizan la tecnología de láser cumplen con los requisitos de láser de Clase 1.

Class 1 Laser Product  
Luokan 1 Laserlaite  
Klasse 1 Laser Apparat  
Laser Klasse 1

## CD ROM/DVD ROM



**Precaución** – El manejo de los controles, los ajustes o la ejecución de procedimientos distintos a los aquí especificados pueden exponer al usuario a radiaciones peligrosas.



# GOST-R Certification Mark

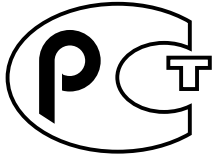

## Nordic Lithium Battery Cautions

### Norge



---

**ADVARSEL** – Litiumbatteri —  
Ekspløsjonsfare. Ved utskifting benyttes kun  
batteri som anbefalt av apparatfabrikanten.  
Brukt batteri returneres apparatleverandøren.

---

### Sverige



---

**VARNING** – Explosionsfara vid felaktigt  
batteribyte. Använd samma batterityp eller  
en ekvivalent typ som rekommenderas av  
apparatillverkaren. Kassera använt batteri  
enligt fabrikantens instruktion.

---

### Danmark



---

**ADVARSEL!** – Litiumbatteri —  
Ekspløsjonsfare ved fejlagtig håndtering.  
Udskiftning må kun ske med batteri af samme  
fabrikat og type. Levér det brugte batteri  
tilbage til leverandøren.

---

### Suomi



---

**VAROITUS** – Paristo voi räjähtää, jos se on  
virheellisesti asennettu. Vaihda paristo  
ainoastaan laitevalmistajan suosittelemaan  
tyyppiin. Hävitä käytetty paristo valmistajan  
ohjeiden mukaisesti.

---



# Index

---

## A

- AC power cord, 2-1, 3-1
- ASIC Port IDs
  - Sun Fire 15K/12K systems, 3-7
- assembly for Sun Fire 15K/12K systems
  - ASIC Port IDs, 3-7
  - FRUs, 3-1 to 3-18
  - handling, 3-2
  - illustration, 3-6
  - inserting in a powered-on system, 3-2
  - installation, 3-10
  - LEDs, 3-7
  - location, 3-4, 3-5
  - PCI slots, 3-6
  - removal, 3-9
  - removal and replacement procedures, 3-1 to 3-18
- assembly for Sun Fire 6800 systems
  - FRUs, 2-1 to 2-15
  - handling, 2-2
  - I/O slots, 2-4
  - illustration, 2-5
  - inserting in a powered-on system, 2-2
  - installation, 2-8
  - installation, illustration of, 2-8
  - LEDs, 2-6
  - location, 2-4
  - removal, 2-6
  - removal and replacement procedures, 2-1 to 2-15
  - removal, illustration of, 2-8

## C

- cables
  - about, 2-14, 3-17
  - connectors, 2-14, 3-17
  - illustration, 2-15, 3-18
  - installation, 2-15, 3-18
  - length, 2-14
- color of connectors, 2-14, 3-17
- connector, cable, color of, 2-14, 3-17

## E

- ESD, 1-2, 1-4

## F

- filler boards
  - Sun Fire 15K/12K systems, 1-5
  - Sun Fire 6800 systems, 1-5
- filler panel
  - Sun Fire 15K/12K systems, 1-5
  - Sun Fire 6800 systems, 1-5
- flexing, avoiding, 1-6
- foot strap, 1-2, 1-4
- FRUs
  - Sun Fire 15K/12K systems, 3-1 to 3-18
  - Sun Fire 6800 systems, 2-1 to 2-15

## G

- grounding, 2-1, 3-1

## H

### heatsink

- loose or broken, 1-6
- protection during shipping, 1-6

## I

### I/O slots

- assembly for Sun Fire 6800 systems, 2-4

### IB8 and IB9, location, 2-4

## L

### LEDs

- for assembly for Sun Fire 15K/12K systems, 3-7
- for optical module, 2-11, 3-13
- for Sun Fire 6800 systems, 2-6
- on optical module, 2-11, 3-13

### length of cables, 2-14, 3-17

## O

### optical module

- illustration, 2-10, 3-12
- inserting in a powered-on system, 2-2, 3-2
- installation, 2-14, 3-16
- installation, illustration of, 2-13, 3-16
- LEDs for optical module, 3-13
- LEDs on assembly, 2-11
- LEDs on optical module, 2-11, 3-13
- removal, 2-13, 3-15
- removal, illustration of, 2-13, 3-16

### overheating, avoiding, 1-5

## P

### PAROLI, *See* optical module

### PCI slots

- assembly for Sun Fire 15K/12K systems, 3-6

### power cord, 2-1, 3-1

### precautions, system, 1-4

## S

### safety, 1-1

### ESD, 1-2, 1-4

### flexing, 1-6

### grounding, 2-1, 3-1

### Sun Fire 15K/12K systems

#### filler boards, 1-5

#### filler panel, 1-5

- See also*, assembly for Sun Fire 15K/12K systems, optical module, and cables

### Sun Fire 6800 systems

#### filler boards, 1-5

#### filler panel, 1-5

- See also*, assembly for Sun Fire 6800 systems, optical module, and cables

### Sun Fire Link assembly for Sun Fire 15K/12K systems, *See* assembly for Sun Fire 15K/12K systems

### Sun Fire Link assembly for Sun Fire 6800 systems,

- See* assembly for Sun Fire 6800 systems

### system precautions, 1-4

## T

### tools required, 1-6

## W

### WCI, *See* ASIC Port IDs

### wrist strap, 1-2, 1-4