

1. Notify users that you are going to bring down the system, then halt operations and power off your host system (system cabinet).
2. Open the expansion cabinet front door and verify that the key switch is in the Standby position.
3. Move to the rear of the cabinet and turn off the power sequencer circuit breaker.
4. Return to the front of the cabinet and loosen and remove the four screws securing the power sequencer filler panel to the chassis.
5. Install the optional power sequencer to the chassis:
 - a. Install the sequencer bottom first so that it rests on the two hooks located on the sequencer bottom.
 - b. Install the four mounting screws.

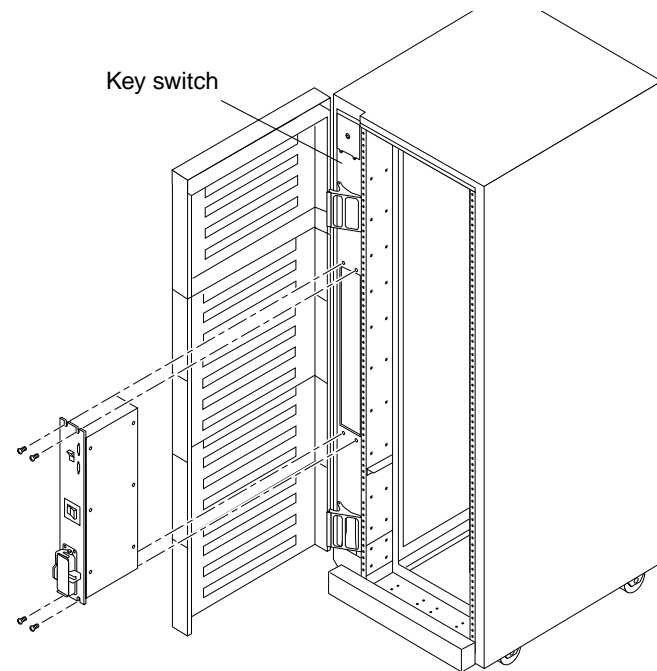

6. Open the cover latch and connect the AC power cord to the power sequencer connector.

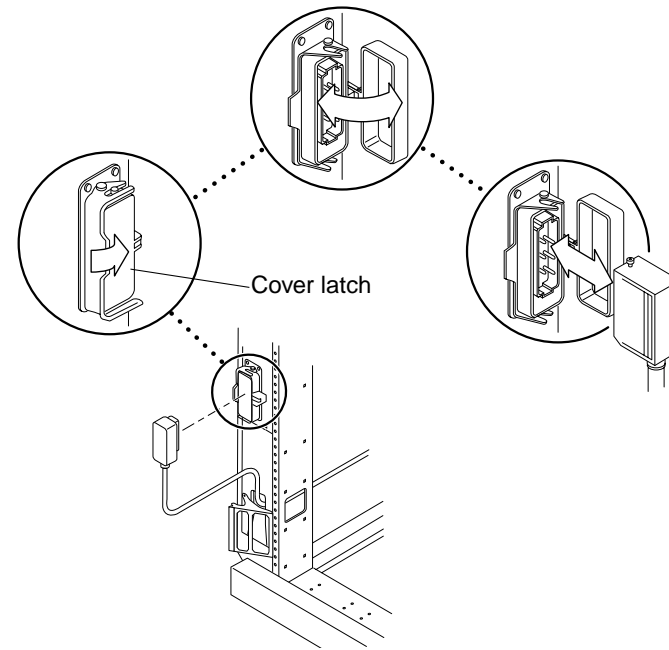

7. Pull the cover latch over the power cord to secure it to the power socket and loosely coil the remaining cord on the floor near the cabinet.
8. Remove the left hand side panel:
 - a. Loosen the two captive screws at the bottom.
 - b. Firmly grasp the outer edges of the side panel and lift the panel from the catches at the top.
9. Move to the rear of the cabinet, then loosen the two screws on the kick panel and remove it. You will see an opening in the cabinet chassis directly below and to the left of the existing sequencer.
10. Return to the cabinet front and route the power cable that you coiled on the floor in step 7, through the opening directly below the optional sequencer, and all the way to the rear of the cabinet chassis.

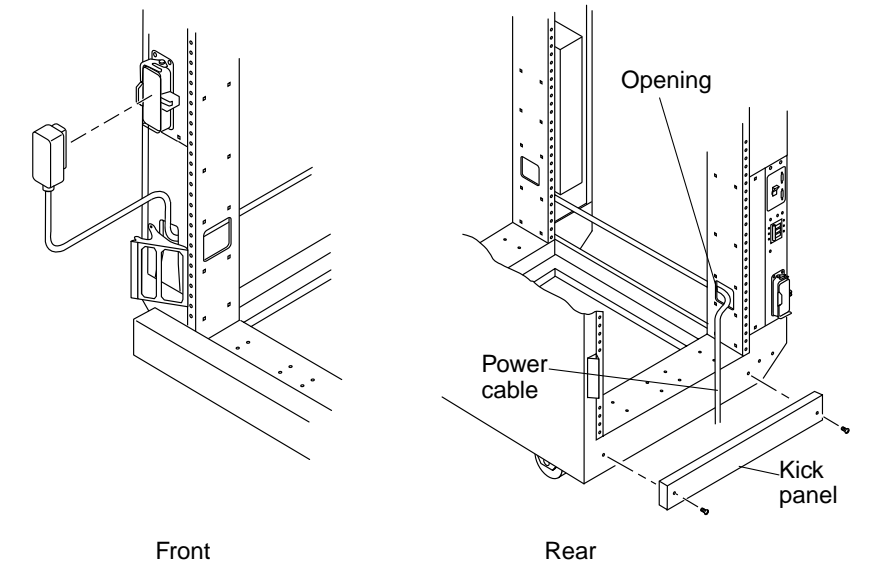

11. Move to the rear of the cabinet, and grasp the power cable through the opening that is directly below and to the left of the existing power sequencer.
12. Dress the sequencer power cable such that it will not hinder the replacement of the kick panel.
13. Secure the kick panel to the cabinet (number 1 mounting holes) with two screws.
14. Disconnect the existing power sequencer key switch cable connector (following Figure) from the adapter cable that goes to the sequencer.
15. Replace this cable with the split adapter cable that came with your optional sequencer.
16. Connect the single end of this cable to the key switch cable and each of the adapter cable split ends to connector J3 of each sequencer.
17. Connect the power cords that came with your optional sequencer to connectors J5 through J12 on the back of the sequencer and tie-wrap the cables.

18. Route the cables towards the rear of the enclosure, up, and then to the inside of the enclosure through the opening in the sheet metal immediately below the fan tray.

At this time, devices in the lower trays should be connected to the existing power sequencer while devices in the upper trays should be connected to the optional power sequencer.

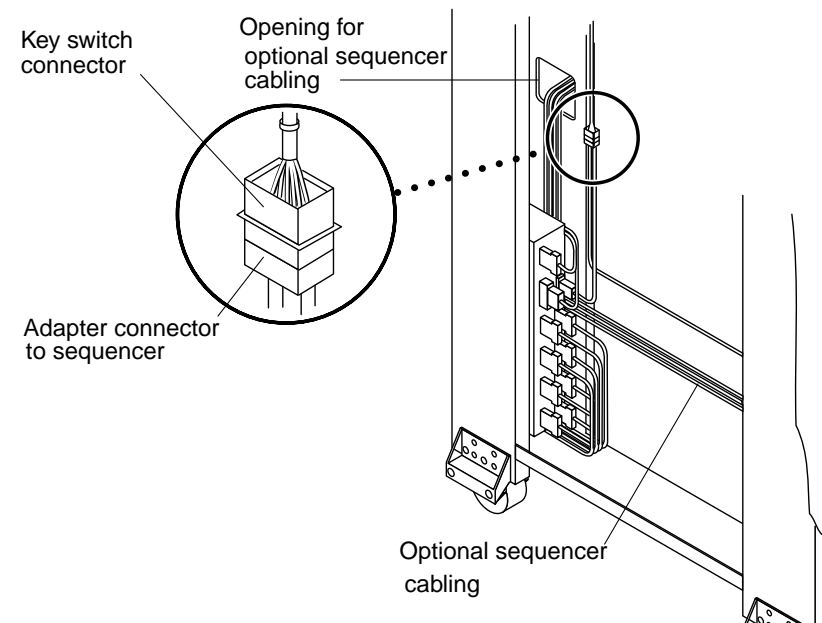

19. Replace the left side panel:

- a. Place the panel against the cabinet so notches on the back of the panel align with ears at the chassis top, and lower the panel into place.
The panel should hang flush against the chassis.
- b. Tighten the two captive screws at the base of the panel.

20. Connect the optional power sequencer power cable to an appropriate power outlet.

21. Power on the system in accordance with the instructions that came with your hardware.

Sun Documentation on the Web

The docs.sun.com web site enables you to access Sun technical documentation on the web. You can browse the docs.sun.com archive or search for a specific book.title or subject at:

<http://docs.sun.com>

Sun Welcomes Your Comments

We are interested in improving our documentation and welcome your comments and suggestions. You can email your comments to us at:

smcc-docs@sun.com

Please include the part number of your document in the subject line of your email.

Copyright 1998 Sun Microsystems, Inc. All rights reserved. Use is subject to license terms. Third-party software, including font technology, is copyrighted and licensed from Sun suppliers. Sun, Sun Microsystems, the Sun Logo, SunDocs, and Solaris are trademarks or registered trademarks of Sun Microsystems, Inc. in the U.S. and other countries. **RESTRICTED RIGHTS:** Use, duplication, or disclosure by the U.S. Government is subject to restrictions of FAR 52.227-14(g)(2)(6/87) and FAR 52.227-19(6/87), or DFAR 252.227-7015(b)(6/95) and DFAR 227.7202-3(a).

Copyright 1998 Sun Microsystems, Inc. Tous droits réservés. Distribué par des licences qui en restreignent l'utilisation. Le logiciel détenu par des tiers, et qui comprend la technologie relative aux polices de caractères, est protégé par un copyright et licencié par des fournisseurs de Sun. Sun, Sun Microsystems, le logo Sun, SunDocs, et Solaris sont des marques de fabrique ou des marques déposées de Sun Microsystems, Inc. aux Etats-Unis et dans d'autres pays.

Sun Microsystems Computer Company • 901 San Antonio Road • Palo Alto, CA 94303-4900 USA • 650-960-1300 • Fax 650 969-9131



Part Number: 805-5621-10
Revision A of May 1998



Sun™ Enterprise™ Expansion Cabinet Optional Power Sequencer



1. Notify users that you are going to bring down the system, then halt operations and power off your host system (system cabinet).
2. Open the expansion cabinet front door and verify that the key switch is in the Standby position.
3. Move to the rear of the cabinet and turn off the power sequencer circuit breaker.
4. Return to the front of the cabinet and loosen and remove the four screws securing the power sequencer filler panel to the chassis.
5. Install the optional power sequencer to the chassis:
 - a. Install the sequencer bottom first so that it rests on the two hooks located on the sequencer bottom.
 - b. Install the four mounting screws.

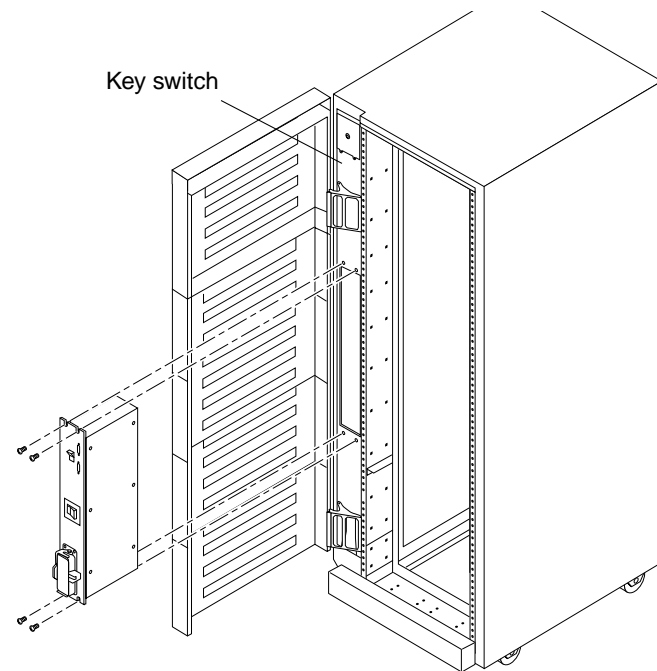

6. Open the cover latch and connect the AC power cord to the power sequencer connector.

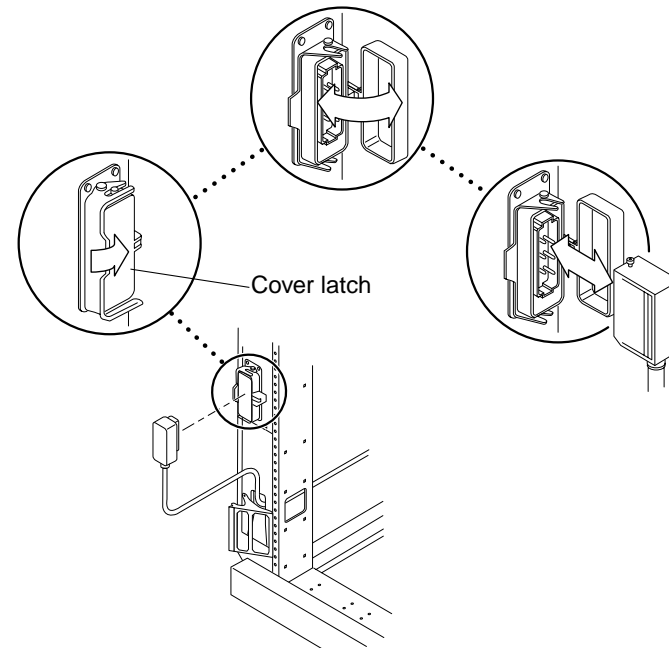

7. Pull the cover latch over the power cord to secure it to the power socket and loosely coil the remaining cord on the floor near the cabinet.
8. Remove the left hand side panel:
 - a. Loosen the two captive screws at the bottom.
 - b. Firmly grasp the outer edges of the side panel and lift the panel from the catches at the top.
9. Move to the rear of the cabinet, then loosen the two screws on the kick panel and remove it. You will see an opening in the cabinet chassis directly below and to the left of the existing sequencer.
10. Return to the cabinet front and route the power cable that you coiled on the floor in step 7, through the opening directly below the optional sequencer, and all the way to the rear of the cabinet chassis.

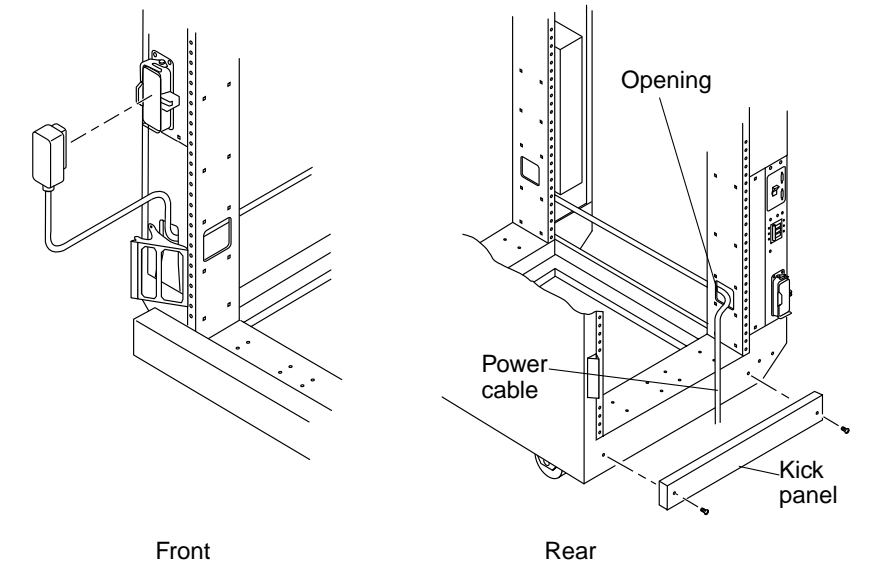

11. Move to the rear of the cabinet, and grasp the power cable through the opening that is directly below and to the left of the existing power sequencer.
12. Dress the sequencer power cable such that it will not hinder the replacement of the kick panel.
13. Secure the kick panel to the cabinet (number 1 mounting holes) with two screws.
14. Disconnect the existing power sequencer key switch cable connector (following Figure) from the adapter cable that goes to the sequencer.
15. Replace this cable with the split adapter cable that came with your optional sequencer.
16. Connect the single end of this cable to the key switch cable and each of the adapter cable split ends to connector J3 of each sequencer.
17. Connect the power cords that came with your optional sequencer to connectors J5 through J12 on the back of the sequencer and tie-wrap the cables.

18. Route the cables towards the rear of the enclosure, up, and then to the inside of the enclosure through the opening in the sheet metal immediately below the fan tray.

At this time, devices in the lower trays should be connected to the existing power sequencer while devices in the upper trays should be connected to the optional power sequencer.

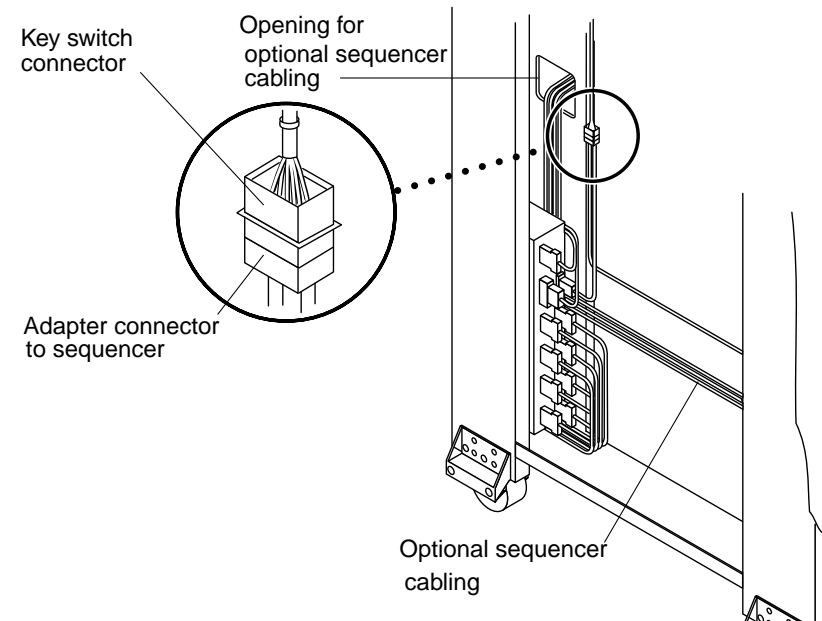

19. Replace the left side panel:

- a. Place the panel against the cabinet so notches on the back of the panel align with ears at the chassis top, and lower the panel into place.

The panel should hang flush against the chassis.

- b. Tighten the two captive screws at the base of the panel.

20. Connect the optional power sequencer power cable to an appropriate power outlet.

21. Power on the system in accordance with the instructions that came with your hardware.

Sun Documentation on the Web

The docs.sun.com web site enables you to access Sun technical documentation on the web. You can browse the docs.sun.com archive or search for a specific book.title or subject at:

<http://docs.sun.com>

Sun Welcomes Your Comments

We are interested in improving our documentation and welcome your comments and suggestions. You can email your comments to us at:

smcc-docs@sun.com

Please include the part number of your document in the subject line of your email.

Copyright 1998 Sun Microsystems, Inc. All rights reserved. Use is subject to license terms. Third-party software, including font technology, is copyrighted and licensed from Sun suppliers. Sun, Sun Microsystems, the Sun Logo, SunDocs, and Solaris are trademarks or registered trademarks of Sun Microsystems, Inc. in the U.S. and other countries. **RESTRICTED RIGHTS:** Use, duplication, or disclosure by the U.S. Government is subject to restrictions of FAR 52.227-14(g)(2)(6/87) and FAR 52.227-19(6/87), or DFAR 252.227-7015(b)(6/95) and DFAR 227.7202-3(a).

Copyright 1998 Sun Microsystems, Inc. Tous droits réservés. Distribué par des licences qui en restreignent l'utilisation. Le logiciel détenu par des tiers, et qui comprend la technologie relative aux polices de caractères, est protégé par un copyright et licencié par des fournisseurs de Sun. Sun, Sun Microsystems, le logo Sun, SunDocs, et Solaris sont des marques de fabrique ou des marques déposées de Sun Microsystems, Inc. aux Etats-Unis et dans d'autres pays.

Sun Microsystems Computer Company • 901 San Antonio Road • Palo Alto, CA 94303-4900 USA • 650-960-1300 • Fax 650 969-9131



Part Number: 805-5621-10
Revision A of May 1998



Sun™ Enterprise™ Expansion Cabinet Optional Power Sequencer

