

# Sun™ Enterprise™ 6x00/ 5x00/4x00/3x00 Systems Site Planning Guide

---



THE NETWORK IS THE COMPUTER™

A Sun Microsystems, Inc. Business  
901 San Antonio Road  
Palo Alto, CA 94303-4900 USA  
650 960-1300 Fax 650 969-9131

Part No.: 805-2817-11  
Revision A, April 1998

Copyright 1998 Sun Microsystems, Inc., 901 San Antonio Road • Palo Alto, CA 94303 USA. All rights reserved.

This product or document is protected by copyright and distributed under licenses restricting its use, copying, distribution, and decompilation. No part of this product or document may be reproduced in any form by any means without prior written authorization of Sun and its licensors, if any. Third-party software, including font technology, is copyrighted and licensed from Sun suppliers.

Parts of the product may be derived from Berkeley BSD systems, licensed from the University of California. UNIX is a registered trademark in the U.S. and other countries, exclusively licensed through X/Open Company, Ltd.

Sun, Sun Microsystems, the Sun logo, AnswerBook, SunDocs, and Solaris, Solstice, SyMON, OpenBoot, Enterprise, SunVTS, Ultra, UltraComputing, UltraServer, and UltraSPARC are trademarks, registered trademarks, or service marks of Sun Microsystems, Inc. in the U.S. and other countries. All SPARC trademarks are used under license and are trademarks or registered trademarks of SPARC International, Inc. in the U.S. and other countries. Products bearing SPARC trademarks are based upon an architecture developed by Sun Microsystems, Inc.

The OPEN LOOK and Sun™ Graphical User Interface was developed by Sun Microsystems, Inc. for its users and licensees. Sun acknowledges the pioneering efforts of Xerox in researching and developing the concept of visual or graphical user interfaces for the computer industry. Sun holds a non-exclusive license from Xerox to the Xerox Graphical User Interface, which license also covers Sun's licensees who implement OPEN LOOK GUIs and otherwise comply with Sun's written license agreements.

**RESTRICTED RIGHTS:** Use, duplication, or disclosure by the U.S. Government is subject to restrictions of FAR 52.227-14(g)(2)(6/87) and FAR 52.227-19(6/87), or DFAR 252.227-7015(b)(6/95) and DFAR 227.7202-3(a).

DOCUMENTATION IS PROVIDED "AS IS" AND ALL EXPRESS OR IMPLIED CONDITIONS, REPRESENTATIONS AND WARRANTIES, INCLUDING ANY IMPLIED WARRANTY OF MERCHANTABILITY, FITNESS FOR A PARTICULAR PURPOSE OR NON-INFRINGEMENT, ARE DISCLAIMED, EXCEPT TO THE EXTENT THAT SUCH DISCLAIMERS ARE HELD TO BE LEGALLY INVALID.

Copyright 1998 Sun Microsystems, Inc., 901 San Antonio Road • Palo Alto, CA 94303 Etats-Unis. Tous droits réservés.

Ce produit ou document est protégé par un copyright et distribué avec des licences qui en restreignent l'utilisation, la copie, la distribution, et la décompilation. Aucune partie de ce produit ou document ne peut être reproduite sous aucune forme, par quelque moyen que ce soit, sans l'autorisation préalable et écrite de Sun et de ses bailleurs de licence, s'il y en a. Le logiciel détenu par des tiers, et qui comprend la technologie relative aux polices de caractères, est protégé par un copyright et licencié par des fournisseurs de Sun.

Des parties de ce produit pourront être dérivées des systèmes Berkeley BSD licenciés par l'Université de Californie. UNIX est une marque déposée aux Etats-Unis et dans d'autres pays et licenciée exclusivement par X/Open Company, Ltd.

Sun, Sun Microsystems, le logo Sun, AnswerBook, SunDocs, et Solaris, Solstice, SyMON, OpenBoot, Enterprise, SunVTS, Ultra, UltraComputing, UltraServer, and UltraSPARC sont des marques de fabrique ou des marques déposées, ou marques de service, de Sun Microsystems, Inc. aux Etats-Unis et dans d'autres pays. Toutes les marques SPARC sont utilisées sous licence et sont des marques de fabrique ou des marques déposées de SPARC International, Inc. aux Etats-Unis et dans d'autres pays. Les produits portant les marques SPARC sont basés sur une architecture développée par Sun Microsystems, Inc.

L'interface d'utilisation graphique OPEN LOOK et Sun™ a été développée par Sun Microsystems, Inc. pour ses utilisateurs et licenciés. Sun reconnaît les efforts de pionniers de Xerox pour la recherche et le développement du concept des interfaces d'utilisation visuelle ou graphique pour l'industrie de l'informatique. Sun détient une licence non exclusive de Xerox sur l'interface d'utilisation graphique Xerox, cette licence couvrant également les licenciés de Sun qui mettent en place l'interface d'utilisation graphique OPEN LOOK et qui en outre se conforment aux licences écrites de Sun.

CETTE PUBLICATION EST FOURNIE "EN L'ETAT" ET AUCUNE GARANTIE, EXPRESSE OU IMPLICITE, N'EST ACCORDEE, Y COMPRIS DES GARANTIES CONCERNANT LA VALEUR MARCHANDE, L'APTITUDE DE LA PUBLICATION A REpondre A UNE UTILISATION PARTICULIERE, OU LE FAIT QU'ELLE NE SOIT PAS CONTREFAISANTE DE PRODUIT DE TIERS. CE DENI DE GARANTIE NE S'APPLIQUERAIT PAS, DANS LA MESURE OU IL SERAIT TENU JURIDIQUEMENT NUL ET NON AVENU.



Adobe PostScript

# Contents

---

**Preface ix**

**1. Environmental and Electrical Specifications 1-1**

- 1.1 Environmental Requirements 1-1
- 1.2 Electrical and Cooling Specifications 1-3
- 1.3 Facility Power Requirements 1-4
  - 1.3.1 Available Connector Plug Types 1-6

**2. Physical Specifications 2-1**

- 2.1 System Components 2-1
- 2.2 General Physical Guidelines 2-6
- 2.3 Size and Space Specifications 2-7
- 2.4 Cable Specifications 2-11
  - 2.4.1 Fiber Cable Length 2-14

**3. Site Planning Checklist 3-1**

- 3.1 System Components 3-1
- 3.2 Miscellaneous 3-1
- 3.3 Environmental Requirements 3-1
- 3.4 Facility Power Requirements 3-2
- 3.5 Physical Specifications 3-2



# Figures

---

- FIGURE 2-1 Enterprise 6x00/5x00 68-Inch System Cabinet and Enterprise 4x00 System 2-2
- FIGURE 2-2 Enterprise 5x00 System (Front and Rear) and Enterprise 6x00 System (Rear) 2-3
- FIGURE 2-3 Sun Enterprise 4x00 System (Front and Rear) 2-4
- FIGURE 2-4 Enterprise 3000 System and Enterprise 3500 System (with Door Open) 2-4
- FIGURE 2-5 Enterprise 3000 System (Front and Rear) 2-5
- FIGURE 2-6 Enterprise 3500 System (Front and Rear) 2-6
- FIGURE 2-7 Enterprise 6x00/5x00 Cabinet Systems Access Areas (Top View) 2-7
- FIGURE 2-8 Enterprise 4x00 Systems Access Areas (Top View) 2-8
- FIGURE 2-9 Enterprise 3x00 Systems Access Areas (Top View) 2-8
- FIGURE 2-10 Types of Network Cables Used 2-12
- FIGURE 2-11 Example of 10/100BASE-T (Twisted-Pair) Ethernet 2-12



# Tables

---

TABLE 1-1	Cabinet Server Environmental Limits	1-2
TABLE 1-2	Sun Enterprise 4x00 Environmental Limits	1-2
TABLE 1-3	Sun Enterprise 3x00 Environmental Limits	1-2
TABLE 1-4	Cabinet Server Electrical Specifications	1-4
TABLE 1-5	Sun Enterprise 4x00 Electrical Specifications	1-5
TABLE 1-6	Sun Enterprise 3000 Electrical Specifications	1-5
TABLE 1-7	Sun Enterprise 3500 Electrical Specifications	1-6
TABLE 2-1	Physical Specifications for Cabinet Server System	2-9
TABLE 2-2	Physical Specifications for Enterprise 4x00 System	2-9
TABLE 2-3	Physical Specifications for Enterprise 3000 System	2-10
TABLE 2-4	Physical Specifications for Enterprise 3500 System	2-11
TABLE 2-5	Ethernet Cabling Limitations for N-Type Coaxial Cable	2-13
TABLE 2-6	Internal SCSI Lengths (Approximate)	2-13





# Preface

---

The *Sun™ Enterprise™ 6x00/5x00/4x00/3x00 Systems Site Planning Guide* helps management and site preparation personnel identify and create suitable environments for the Enterprise cabinet and standalone server systems. It describes physical configurations, electrical requirements, power consumption, cooling requirements, and other environmental requirements and guidelines.

Due to the amount of time required to plan and properly prepare a site for installation of an Enterprise server system, you should fulfill all of the requirements outlined in this manual before your equipment arrives. Your Sun Microsystems account manager is always available to help.

---

## How This Book Is Organized

This book is organized into three chapters:

**Chapter 1 “Environmental and Electrical Specifications”** lists electrical and cooling specifications requirements.

**Chapter 2 “Physical Specifications”** lists system components, size and space requirements, and cable lengths and limitations.

**Chapter 3 “Site Planning Checklist”** is a worksheet that is useful in planning your space and double-checking details.

---

# Typographic Conventions

TABLE P-1 Typographic Conventions

Typeface or Symbol	Meaning	Examples
AaBbCc123	The names of commands, files, and directories; on-screen computer output.	Edit your <code>.login</code> file. Use <code>ls -a</code> to list all files. % You have mail.
<b>AaBbCc123</b>	What you type, when contrasted with on-screen computer output.	% <b>su</b> Password:
<i>AaBbCc123</i>	Book titles, new words or terms, words to be emphasized. Command-line variable; replace with a real name or value.	Read Chapter 6 in the <i>User's Guide</i> . These are called <i>class</i> options. You <i>must</i> be <i>root</i> to do this. To delete a file, type <code>rm filename</code> .

---

# Shell Prompts

TABLE P-2 Shell Prompts

Shell	Prompt
C shell	<i>machine_name</i> %
C shell superuser	<i>machine_name</i> #
Bourne shell and Korn shell	\$
Bourne shell and Korn shell superuser	#

---

# Related Documentation

Table P-3 Books Related to This Documentation

<b>Application</b>	<b>Title</b>	<b>Part Number</b>
Installation	<i>Ultra Enterprise 3000 System Installation Guide</i>	802-6050
	<i>Ultra Enterprise 6000/5000/4000 Systems Installation Guide</i>	802-3844
	<i>Sun Enterprise 3500 System Installation Guide</i>	805-2629
	<i>Sun Enterprise 6500/5500/4500 Systems Installation Guide</i>	805-2631
Operation	<i>Ultra Enterprise 3000 System Manual</i>	802-6051
	<i>Ultra Enterprise 6000/5000/4000 Systems Manual</i>	802-3845
	<i>Sun Enterprise 3500 System Reference Manual</i>	805-2630
	<i>Sun Enterprise 6500/5500/4500 Systems Reference Manual</i>	805-2632
Software	<i>SMCC SPARC Hardware Platform Guide</i>	802-5341
	<i>Solstice SyMON User's Guide</i>	802-5355
	<i>Dynamic Reconfiguration User's Guide for Sun Enterprise 6x00/5x00/4x00/3x00 Systems</i>	805-3530
Options	<i>Expansion Cabinet Installation and Service Manual</i>	802-6084
	<i>Sun Enterprise Expansion Cabinet Installation and Service Manual</i>	805-4009
	<i>Enterprise Systems Boards Installation Guide</i>	802-5030
	<i>Sun Enterprise 6/5/4/3x00 Board Installation Guide</i>	805-4007
	<i>Rackmount Placement Matrix</i>	802-6945
	<i>PCI+ I/O Board Installation and Component Replacement for Sun Enterprise 6/5/4/3x00 Systems</i>	805-1372
	<i>SBus+ and Graphics+ I/O Boards (100 MB/sec Fibre Channels) for Sun Enterprise 6/5/4/3x00 Systems</i>	805-2704
	<i>UltraSPARC Module Installation Guide</i>	802-5031
	<i>4 Mbyte UltraSPARC II Installation Guide</i>	805-1150
	<i>Enterprise Systems Memory Modules Installation Guide</i>	802-5032
	<i>Enterprise Systems Peripheral Power Supply Installation Guide</i>	802-5033
<i>Sun Enterprise 3500 Auxiliary Peripheral Power Supply Installation Guide</i>	805-4012	
<i>Enterprise Systems Power/Cooling Module Installation Guide</i>	802-6244	

---

## Sun Documentation on the Web

The `docs.sun.com` web site enables you to access Sun technical documentation on the World Wide Web. You can browse the `docs.sun.com` archive or search for a specific book title or subject at <http://docs.sun.com/>.

---

## Sun Welcomes Your Comments

We are interested in improving our documentation and welcome your comments and suggestions. You can email your comments to us at `smcc-docs@sun.com`. Please include the part number of your document in the subject line of your email.

# Environmental and Electrical Specifications

---

---

## 1.1 Environmental Requirements

The design of your environmental control system—such as computer room air-conditioning units—must ensure that intake air to the server system complies with the limits specified in this section.

To avoid overheating, also:

- guard against directing any warmed air toward the bottom of the cabinet or standalone server.
- guard against directing warmed air toward the server access panels.

For environmental limits for Sun Enterprise systems, see the following tables:

1. Sun Enterprise 6x00 and 5x00 systems: see Table 1-1
2. Sun Enterprise 4x00 systems: see Table 1-2
3. Sun Enterprise 3x00 systems: see Table 1-3

---

**Note** – When you receive your system—to prevent thermal shock and condensation—leave the system in the shipping crate at its final destination *for 24 hours* if the system is significantly colder [ 40 °F (4 °C) or colder ] than the environment in which you will install it.

---

**TABLE 1-1 Cabinet Server Environmental Limits**

<b>Environmental Factor</b>	<b>Temperature Range</b>	<b>Relative Humidity Range</b>	<b>Altitude</b>
Operating	41 °F to 95 °F (5 °C to 35 °C)	20% to 80% (noncondensing), 27C max wb	9,843 ft (3 km)
Nonoperating	-4 °F to 140 °F (-20 °C to 60 °C)	93%	39,370 ft (12 km)

**TABLE 1-2 Sun Enterprise 4x00 Environmental Limits**

<b>Environmental Factor</b>	<b>Temperature Range</b>	<b>Relative Humidity Range</b>	<b>Altitude</b>
Operating	41 °F to 104 °F (5 °C to 40 °C) *Maximum is 95 °F (35 °C) when using tape media.	5% to 93% (noncondensing), 27C max wb	9,843 ft (3 km)
Nonoperating	-4 °F to 140 °F (-20 °C to 60 °C)	93%	39,370 ft (12 km)

**TABLE 1-3 Sun Enterprise 3x00 Environmental Limits**

<b>Environmental Factor</b>	<b>Temperature Range</b>	<b>Relative Humidity Range</b>	<b>Altitude</b>
Operating*	41 °F to 104 °F (5 °C to 40 °C) *Maximum is 95 °F (35 °C) when using tape media.	20% to 80% (noncondensing), 27C max wb	9,843 ft (3 km)
Nonoperating	-4 °F to 140 °F (-20 °C to 60°C)	93%	39,370 ft (12 km)

## 1.2 Electrical and Cooling Specifications

This section provides guidelines and requirements for cooling your Sun Enterprise systems. For electrical and cooling specifications, see the following tables:

1. Sun Enterprise 6x00 and 5x00 systems: see Table 1-4
2. Sun Enterprise 4x00 systems: see Table 1-5
3. Sun Enterprise 3000 system: see Table 1-6
4. Sun Enterprise 3500 system: see Table 1-7

Be aware of the following system cooling rules and guidelines:

1. *(Requirement)* Provide one power/cooling module (PCM) for every two boards. You must install the PCMs adjacent to populated board slots to ensure that the fan in the PCM can cool the respective boards.

---

**Note** – All boards in the Enterprise systems must be adjacent to PCMs, and a PCM or an auxiliary fan tray *must be working in PCM slot 5* of the Enterprise 3x00 systems. All PCM slots in Enterprise systems must have either a PCM, a PCM filler panel, or an auxiliary fan tray installed. All empty board slots in Enterprise 5x00/4x00/3x00 systems must have a filler panel installed to ensure proper cooling. All empty slots in Enterprise 6x00 systems must have load boards installed.

---

2. *(Requirement)* Do not install a board in a slot that is not cooled by a PCM.
3. Under some circumstances, you may remove a PCM from an active system for a short period of time. However, if the boards in the adjacent slots create excessive heat, it is safer to halt and power down the system first.
4. The room should have sufficient air-conditioning capacity to support the cooling needs of the entire system.
5. The air-conditioning system should have controls that prevent excessive temperature changes.

---

## 1.3 Facility Power Requirements

To prevent catastrophic failures, the design of your power system must ensure that adequate power is provided to your Sun Enterprise system. Using dedicated AC breaker panels for all power circuits that supply power to your system helps ensure this. Electrical work and installations must comply with applicable local, state, or national electrical codes.

If the computer equipment is subjected to repeated power interruptions and fluctuations, it is susceptible to a higher component failure rate than it would be with a stable power source. Provide a stable power source, such as an uninterruptible power system (UPS), to reduce the possibility of component failures.

Every Enterprise 6x00/5x00/4x00/3x00 system, as well as each peripheral and monitor, requires its own customer-supplied circuit breaker and AC receptacle.

Every piece of support equipment requires its own customer-supplied circuit breaker and receptacle(s).

**TABLE 1-4** Cabinet Server Electrical Specifications

Parameter		Value
Input current	Voltage range	200-240 Vac
	Current, maximum	24A
	Current frequency range	47-63 Hz
Input power rating	Total continuous power	3500W (with 3 drive trays)
Volt-Ampere rating		3700 VA
BTU rating		12,000 BTU
Power factor		0.92 - 0.96
Plug type	U.S.	NEMA L6-30P for 200-240 Vac
	International	32A, single-phase IEC 309, connected for 220-240 Vac



**TABLE 1-5 Sun Enterprise 4x00 Electrical Specifications**

<b>Parameter</b>	<b>Value</b>	
Input current	Voltage range	100-120 or 200-240 Vac
	Current, maximum	12A
	Current frequency range	47-63 Hz
Input power rating	Total continuous power	1370W
Volt-Ampere rating		1440 VA
BTU rating		4680 BTU
Power factor		0.92 - 0.96
Plug type	U.S.	NEMA 5-15P
	International	10A, single-phase IEC 320, connected for 220-240 Vac

**TABLE 1-6 Sun Enterprise 3000 Electrical Specifications**

<b>Parameter</b>	<b>Value</b>	
Input current	Voltage range	100-120 or 200-240 Vac
	Current, maximum	8.5A
	Current frequency range	47-63 Hz
Input power rating	Total continuous power	750W
Volt-Ampere rating		825 VA
BTU rating		2600 BTU
Power factor		0.92 - 0.96
Plug type	U.S.	NEMA 5-15P
	International	10A, single-phase IEC 320, c14

**TABLE 1-7** Sun Enterprise 3500 Electrical Specifications

<b>Parameter</b>		<b>Value</b>
<b>Input current</b>	<b>Voltage range</b>	100-120 Vac or 200-240 Vac
	Current, maximum	9.5@100 V
	Current frequency range	47-63 Hz
<b>Input power rating</b>	<b>Total continuous power</b>	875W
<b>Volt-Ampere rating</b>		950 VA
<b>BTU rating</b>		3000 BTU
<b>Power factor</b>		0.92 - 0.96
<b>Plug type</b>	U.S.	NEMA 5-15P
	International	10A, single phase IEC 320, C14

## 1.3.1 Available Connector Plug Types

Various AC connector type plugs are available for Sun Enterprise systems:

- Cabinet servers: AC input power cable for 200–240V North American operation has a NEMA L6–30P connector that plugs into the AC source on one end. The other end, with metal housing, plugs into the sequencer.
- Cabinet servers: AC input power cable for 200–240V international operation has a 32A, single-phase, IEC 309 connector that plugs into the AC source on one end. The other end, with metal housing, plugs into the sequencer.
- Enterprise 4x00 and Enterprise 3x00 servers: AC input power cable for North American operation is a NEMA 5–15P connector; for international operation it is a 10A, single-phase, IEC 320 connector.

# Physical Specifications

---

This chapter provides information about the physical characteristics of the Sun Enterprise 6x00/5x00/4x00/3x00 systems, including dimensions, space needs, and cable sizes and limitations.

---

## 2.1 System Components

Sun Enterprise systems are available in the following enclosures:

- Enterprise 6x00 data center system cabinet containing a 16-slot card cage
- Enterprise 5x00 data center system cabinet containing an 8-slot card cage

---

**Note** – The Enterprise 6000 and 5000 systems are in a 56-inch cabinet (four panels). The Enterprise 6500 and 5500 systems are in a 68-inch cabinet (five panels).

---

- Enterprise 4x00 standalone enclosure containing an 8-slot card-cage
- Enterprise 3000 standalone enclosure containing a 4-slot card cage
- Enterprise 3500 standalone enclosure containing a 5-slot card cage

The same CPU/Memory or CPU/Memory+ boards, I/O or I/O+ boards, PCI or PCI+ boards, UltraSPARC™ CPU modules, memory modules, power supplies, and fans are used in the Enterprise enclosures.

The Enterprise 6x00/5x00/4x00 systems support the same Disk board. The Disk board is not supported in Enterprise 3x00 systems since they have internal disk bays.

---

**Note** – The Enterprise 6500/5500/4500/3500 systems support the “plus (+)” boards (such as Clock+, CPU/Memory+, I/O+, and PCI+), and the UltraSPARC II CPU module.

---

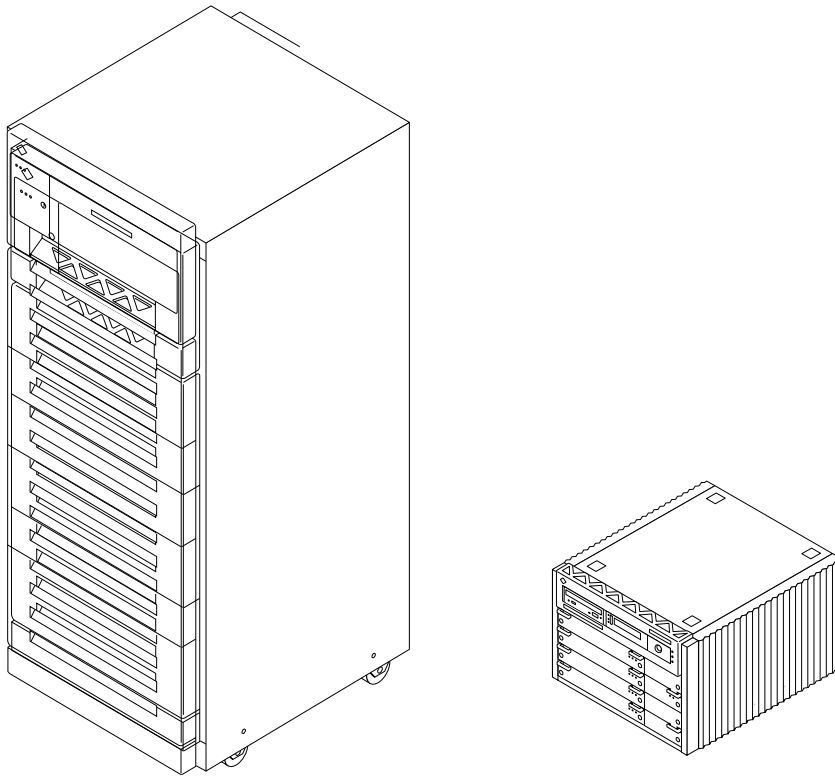

**FIGURE 2-1** Enterprise 6x00/5x00 68-Inch System Cabinet and Enterprise 4x00 System

The minimum configuration for the Enterprise 6x00/5x00 systems is:

- Data center system cabinet
- 16-slot or 8-slot card cage
- Power/cooling modules (PCM) (2) or PCM filler panels
- Quad fan tray
- Clock or Clock+ board
- CPU/Memory or CPU/Memory+ board
- UltraSPARC or UltraSPARC II module
- Main memory
- I/O or I/O+ board
- Load boards for any unpopulated board slots (16-slot only) or board filler panels for any unpopulated board slots (8-slot only)
- Peripheral power supply
- AC power sequencer
- SCSI receptacle for removable media, including the SunCD™ drive

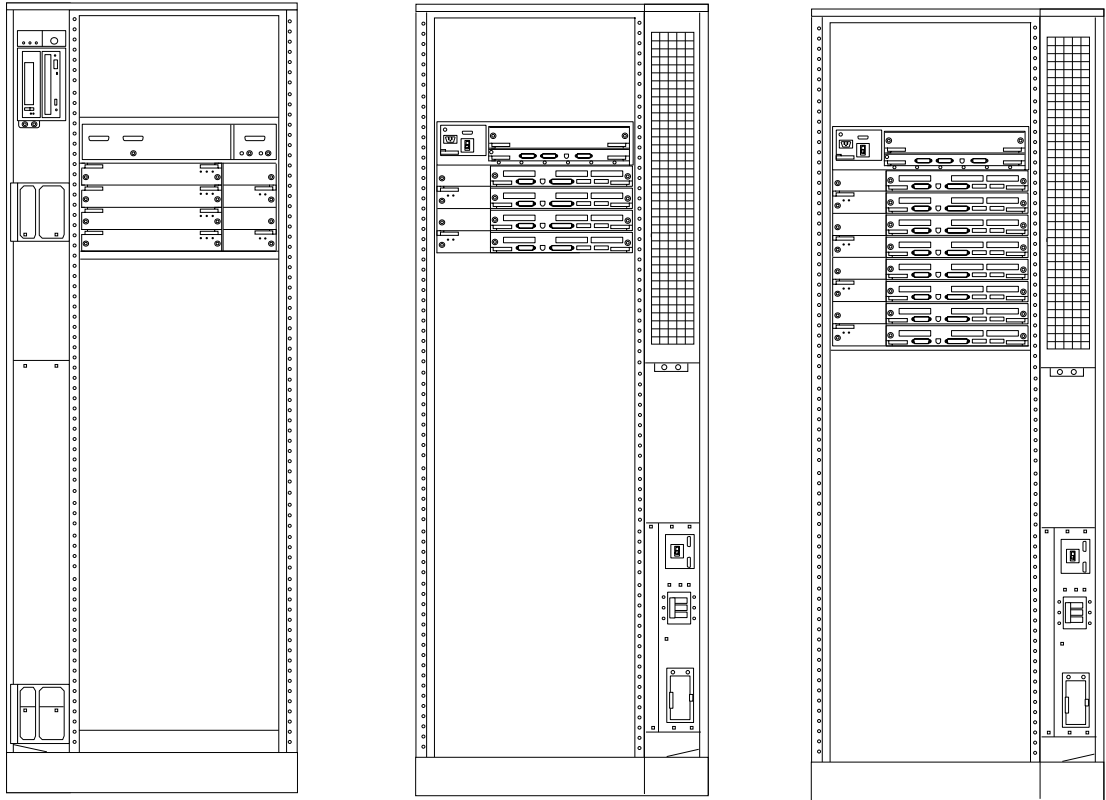

**FIGURE 2-2** Enterprise 5x00 System (Front and Rear) and Enterprise 6x00 System (Rear)

The minimum configuration for the Enterprise 4x00 system is:

- 8-slot card cage
- Power/cooling modules (2) or PCM filler panels
- Fan box
- Clock or Clock+ board
- CPU/Memory or CPU/Memory+ board
- UltraSPARC or UltraSPARC II module
- Main memory
- I/O or I/O+ board
- Board filler panels for any unpopulated board slots
- Peripheral power supply
- AC power sequencer
- SCSI receptacle for removable media, including the SunCD drive

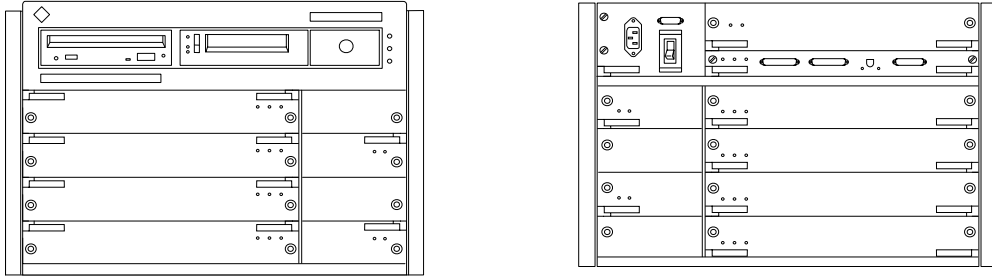

**FIGURE 2-3** Sun Enterprise 4x00 System (Front and Rear)

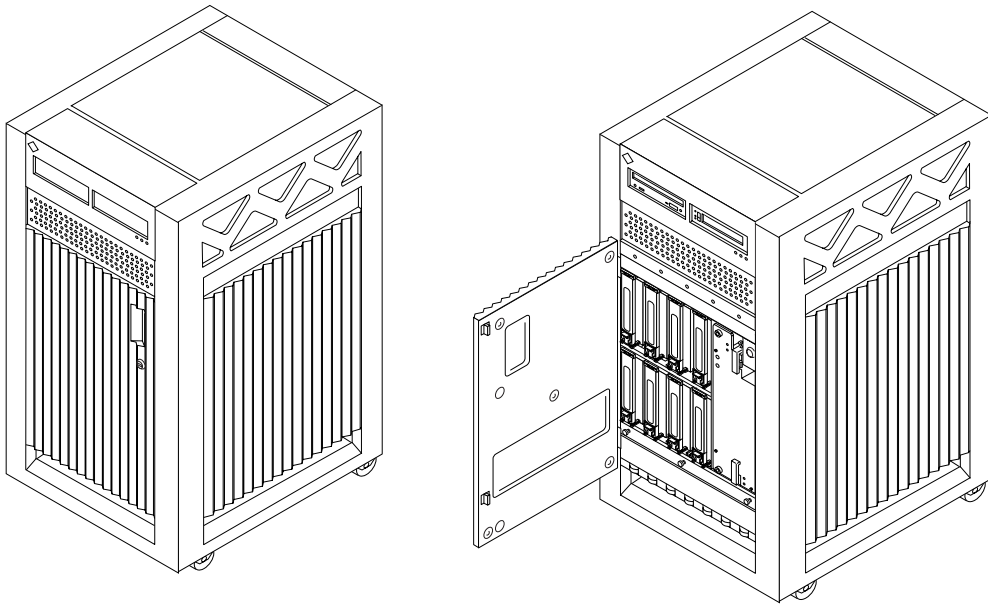

**FIGURE 2-4** Enterprise 3000 System and Enterprise 3500 System (with Door Open)

The minimum configuration for the Enterprise 3000 system is:

- 4-slot card cage
- Power/cooling modules or PCM filler panels
- Fan tray
- Clock board
- CPU/Memory board
- UltraSPARC module
- Main memory
- I/O board
- Board filler panels for any unpopulated board slots
- Peripheral power supply with A/C power sequencer
- SCSI receptacle for removable media, including the SunCD drive

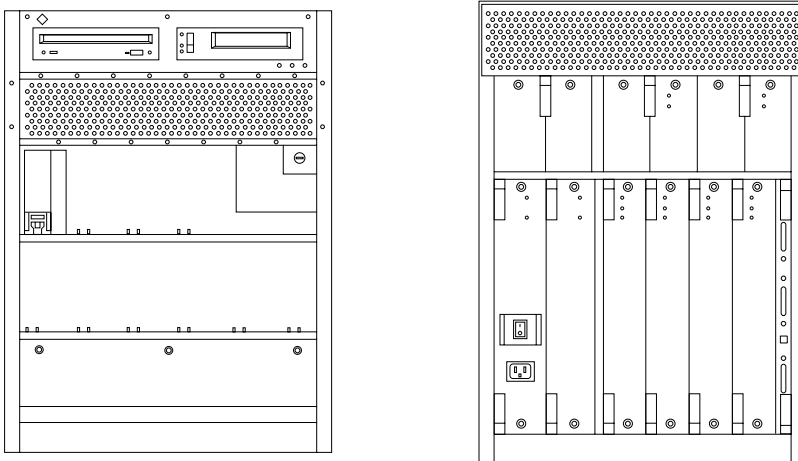

**FIGURE 2-5** Enterprise 3000 System (Front and Rear)

The minimum configuration for the Enterprise 3500 system is:

- 5-slot card cage
- Power/cooling modules or PCM filler panels
- Fan tray
- Clock+ board
- CPU/Memory+ board
- UltraSPARC II module
- Main memory
- I/O+ board
- Board filler panels for any unpopulated board slots
- Interface board (IB) or IB filler panel
- Peripheral power supply with A/C power sequencer
- Auxiliary peripheral power supply or thermal protection module
- SCSI receptacle for removable media, including the SunCD drive

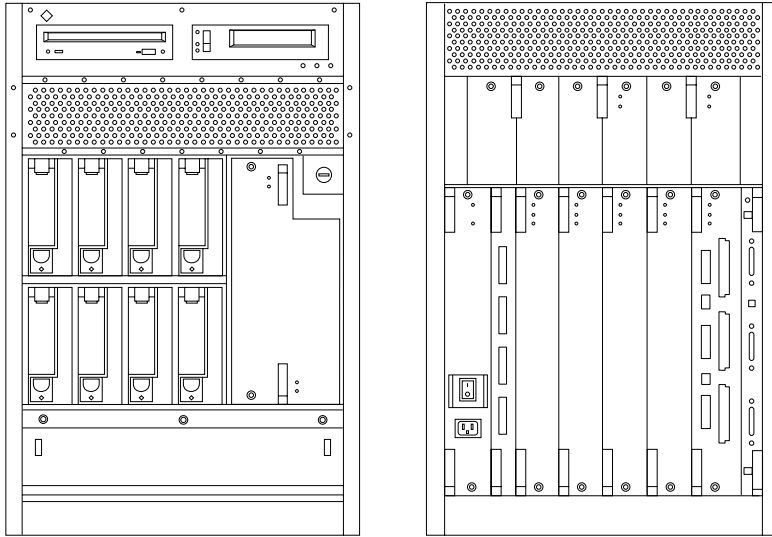

FIGURE 2-6 Enterprise 3500 System (Front and Rear)

---

## 2.2 General Physical Guidelines

As you plan your space needs for either the Enterprise 6x00/5x00 server cabinet systems, or the Enterprise 4x00 and Enterprise 3x00 systems, keep these conditions in mind:

- Each system, each external peripheral device, and each monitor requires its own power cord, plugged separately into a power outlet (see Chapter 1 “Environmental and Electrical Specifications for details on electrical requirements.)
- Both the 16-slot and 8-slot system cabinets require a 30A circuit and a detachable cable. The equipment requires a 30A circuit breaker, supplied by the customer.
- The system requires an electrical circuit that is grounded to earth.
- The cabinet server system can weigh up to a half-ton (500 kilograms), and can be unstable when rolling down ramps; use caution.

Consult your *Systems Installation Guide* for complete installation details.



---

## 2.3 Size and Space Specifications

- A minimum space of 3 feet (91 cm) is recommended to avoid exhaust air recirculation if Sun Enterprise 4x00 systems are placed next to each other.
- Server and expansion cabinets can be placed next to each other, without space between them, since there are no side clearance requirements during operation. To access and remove side panels, however, allow approximately 1 foot (30 cm) of space on the sides.

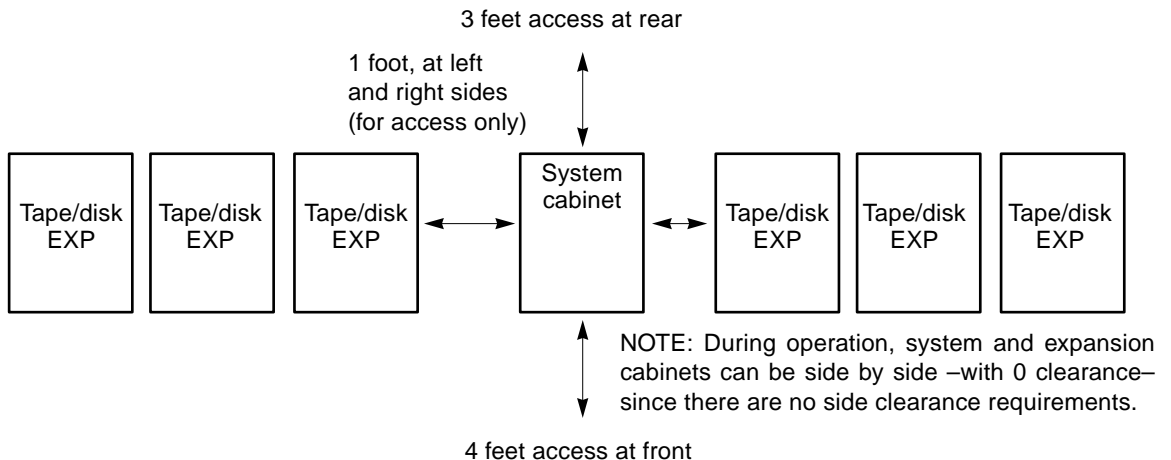
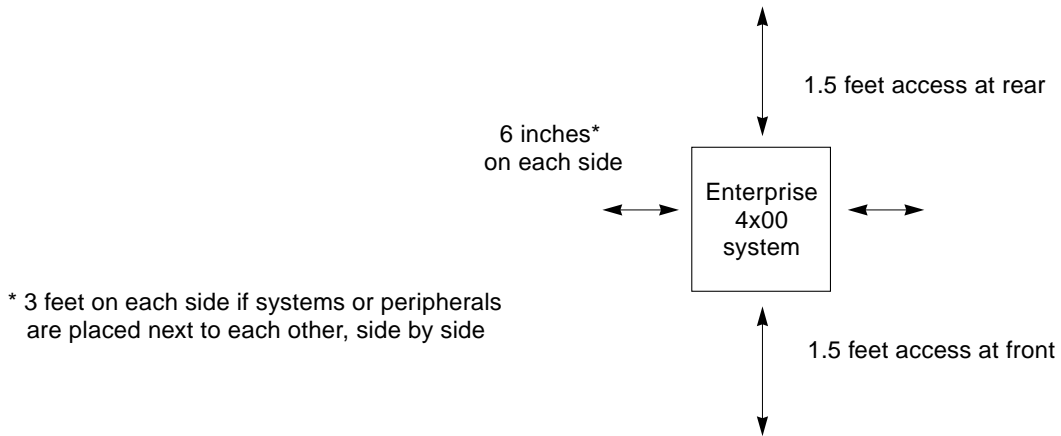
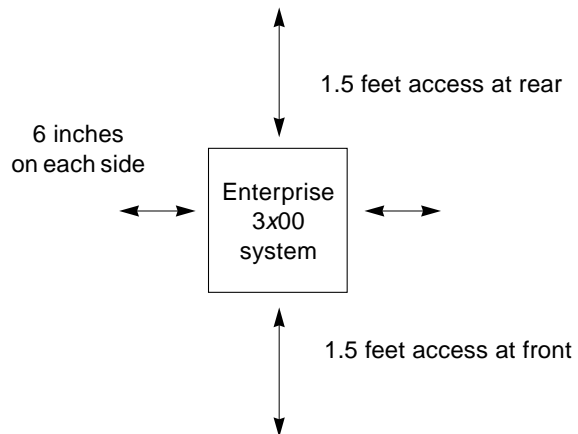

FIGURE 2-7 Enterprise 6x00/5x00 Cabinet Systems Access Areas (Top View)



**FIGURE 2-8** Enterprise 4x00 Systems Access Areas (Top View)



**FIGURE 2-9** Enterprise 3x00 Systems Access Areas (Top View)

To determine space requirements for Enterprise servers, use the following tables:

1. Sun Enterprise 6x00 and 5x00 systems: see Table 2-1 on page 9
2. Sun Enterprise 4x00 systems: see Table 2-2 on page 9
3. Sun Enterprise 3000 system: see Table 2-3 on page 10
4. Sun Enterprise 3500 system: see Table 2-4 on page 11

**TABLE 2-1** Physical Specifications for Cabinet Server System

Characteristic	Value
Shipping height	62.0 in. (157 cm)
Shipping width	39 in. (99 cm)
Shipping depth	44.5 in. (113 cm)
Shipping weight	875 lbs, approx. (397 kg, approx.)
Height	56 in. (143 cm)
Width	30 in. (77 cm)
Depth	39 in. (99 cm)
Weight	800 lbs, approx. (360 kg, approx.)
Power cord length	15 ft. (4.6 m)
Access requirement for front	4 ft. (122 cm)
Access requirement for rear	3 ft. (92 cm)
Air flow requirement for left and right sides	0**

\*\*During operation, system and expansion cabinets can be side by side—with 0 clearance—since there are no side clearance requirements. Allow 1 ft/31 cm clearance for access only.

**TABLE 2-2** Physical Specifications for Enterprise 4x00 System

Characteristic	Value
Shipping height	19 in. (48 cm)
Shipping width	23.8 in. (60 cm)
Shipping depth	26.8 in. (68 cm)
Shipping weight	160 lbs, approx. (72 kg, approx.)

**TABLE 2-2** Physical Specifications for Enterprise 4x00 System

<b>Characteristic</b>	<b>Value</b>
Height	13.5 in. (34 cm)
Width	19.7 in. (50 cm)
Depth	22 in. (56 cm)
Weight	150 lbs, approx. (68 kg, approx.)
Power cord length	6 ft. (1.8 m)
Access requirement for front	18 in. (47 cm)
Access requirement for rear	18 in. (47 cm)
Air flow requirement for left side	6 in. (16 cm)
Air flow requirement for right side	6 in. (16 cm)

\*\* Sufficient to prevent blocking the in and out airflow of a single system. To avoid exhaust air recirculation, allow 3 feet on each side (36 in./92 cm) if systems or peripherals are placed next to each other, side by side.

**TABLE 2-3** Physical Specifications for Enterprise 3000 System

<b>Characteristic</b>	<b>Value</b>
Shipping height	34 in. (86 cm)
Shipping width	29 in. (74 cm)
Shipping depth	22.5 in. (57 cm)
Shipping weight	185 lbs, approx. (84 kg, approx.)
Height	25.5 in. (64.5 cm)
Width	17 in. (43.2 cm)
Depth	23.5 in. (59.7 cm)
Weight	160 lbs, approx. (72.7 kg, approx.)
Power cord length	6 ft. (1.8 m)
Access requirement for front	18 in. (47 cm)
Access requirement for rear	18 in. (47 cm)
Air flow requirement for left side	6 in.** (16 cm)
Air flow requirement for right side	6 in.** (16 cm)

**TABLE 2-4** Physical Specifications for Enterprise 3500 System

<b>Characteristic</b>	<b>Value</b>
Shipping height	34 in. (86 cm)
Shipping width	29 in. (74 cm)
Shipping depth	22.5 in. (57 cm)
Shipping weight	220 lbs, approx. (100 kg, approx.)
Height	25.5 in. (64.5 cm)
Width	17 in. (43.2 cm)
Depth	23.5 in. (59.7 cm)
Weight	185 lbs, approx. (84 kg, approx.)
Power cord length	6 ft. (1.8 m)
Access requirement for front	18 in. (47 cm)
Access requirement for rear	18 in. (47 cm)
Air flow requirement for left side	6 in. (16 cm)
Air flow requirement for right side	6 in. (16 cm)

---

## 2.4 Cable Specifications

This section contains information about Ethernet, SCSI, and fiber optic cable limitations.

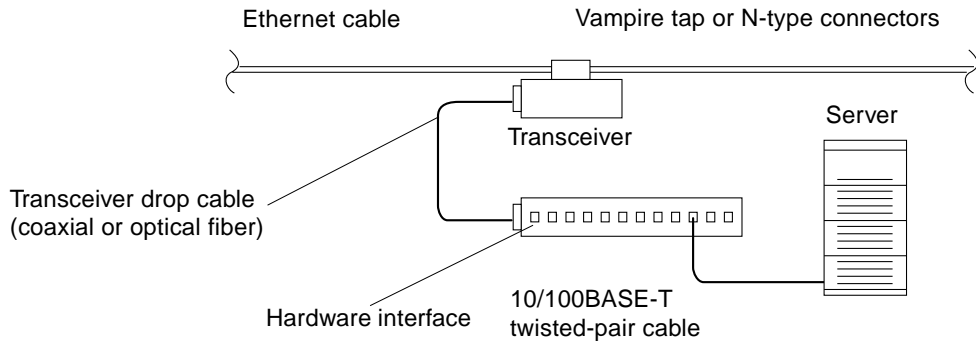

**FIGURE 2-10** Types of Network Cables Used

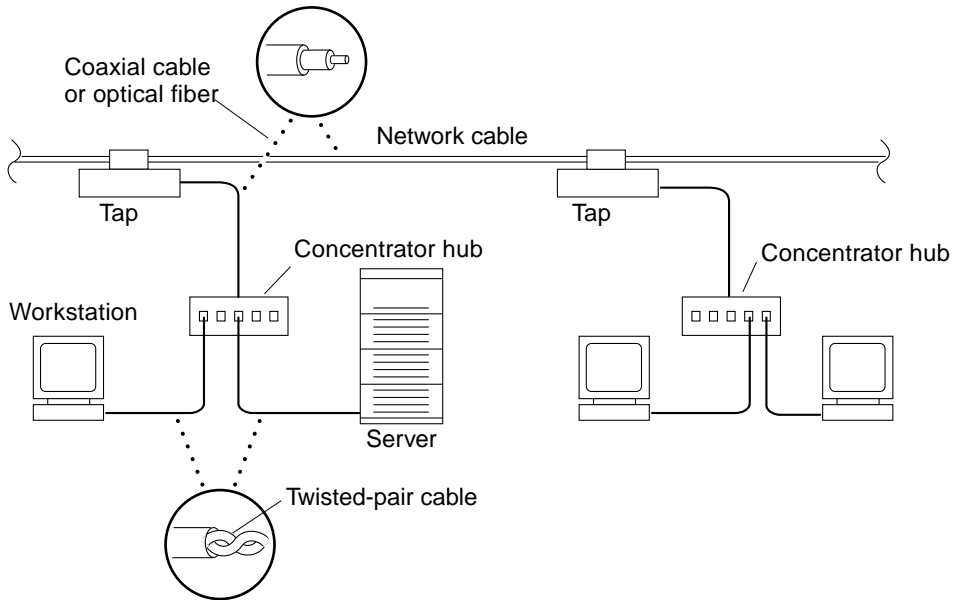

**FIGURE 2-11** Example of 10/100BASE-T (Twisted-Pair) Ethernet

**TABLE 2-5 Ethernet Cabling Limitations for N-Type Coaxial Cable**

Cable Segment	Length (in Meters)
Allowed continuous length of cable segments	23.4
	70.2
	117
	500 <sup>1</sup>
Distance between transceivers (multiples-of)	2.5 <sup>2</sup>
Minimum length of Ethernet coaxial cable segments	23.4
Maximum length of transceiver “drop” cable	50
Minimum length of twisted-pair cable	(none)
Maximum length of twisted-pair cable	110

1. Finite lengths (as constrained by transmission line phenomena). Minimum length is 23.4M; maximum length is 500M. If cable is shorter than one of these values, add cable to achieve next-highest value.
2. Transceivers are placed at intervals of 2.5 meters, or multiples of 2.5 meters, along the Ethernet cable. Example: Transceivers are connected 2.5 meters apart, not 2.0 meters. Example: Transceivers are connected 15 meters apart (six multiple of 2.5 meters), not 14 meters.

**TABLE 2-6 Internal SCSI Lengths (Approximate)**

Location	Internal Length	Comments
Enterprise 6x00 slot 1	3.7 meters	Includes I/O board traces and cables to SCSI tray
Enterprise 5x00 slot 1	3.7 meters	Includes I/O board traces and cables to SCSI tray
Enterprise 4x00 slot 1	1.4 meters	Includes I/O board traces and cables to SCSI tray
SBus and SBus+ I/O boards	0.43 meter	Includes board traces only
Graphics and Graphics+ I/O boards	0.43 meter	Includes board traces only
Disk board**	0.64 meter	Includes board traces only

\*\* Disk boards can be installed *only in slots 14 and 15 in Enterprise 6x00 systems*, and slot 15 *must* be used when installing only one Disk board. Use an 80 cm SCSI cable when installing the Disk board in slot 15; use a 2-meter SCSI cable when installing the Disk board in slot 14 (if all I/O or I/O+ boards are installed in the rear board slots).

## 2.4.1 Fiber Cable Length

Use a 2-meter cable to ensure that the 1.0 inch minimum bend radius rule for fiber optic cables is observed.



## Site Planning Checklist

---

Prior to system installation, confirm that the following requirements have been met.

---

### 3.1 System Components

- Has the system configuration been determined?
- What is the total number of systems?

---

### 3.2 Miscellaneous

- Have system administrators and operators been enrolled in the necessary Sun Microsystems training courses?

---

### 3.3 Environmental Requirements

- Does the computer room environment meet the temperature and humidity specifications listed in Table 1-1 on page 2, Table 1-2 on page 2, or Table 1-3 on page 2?
- Can the computer room environment specifications be maintained satisfactorily?
- Is additional fire suppression equipment required?

---

## 3.4 Facility Power Requirements

- At what voltage will the processing cabinet and peripheral cabinet(s) be operated?
- Have sufficient power receptacles been ordered for each system, monitor, and peripheral?
- Are circuit breakers properly installed and labeled?
- Are the power receptacles within 15 feet (4.6 meters) of the server cabinet system, or within 6 feet (1.8 meters) of the standalone server system?

---

## 3.5 Physical Specifications

- Has the system location been established?
- Does the equipment floor layout meet the equipment maintenance access and air flow requirements?
- Is the equipment positioned so that the exhaust air of one heat-rejecting device does not enter the air inlet of another?