



Sun Enterprise™ 3500 System Installation Guide

Sun Microsystems, Inc.
901 San Antonio Road
Palo Alto, CA 94303
U.S.A. 650-960-1300

Part No. 805-2629-11
August 2001 , [Revision A](#)

[Send comments about this document to: docfeedback@sun.com](mailto:docfeedback@sun.com)

Copyright 2001 Sun Microsystems, Inc., 901 San Antonio Road, Palo Alto, CA 94303-4900 U.S.A. All rights reserved.

This product or document is distributed under licenses restricting its use, copying, distribution, and decompilation. No part of this product or document may be reproduced in any form by any means without prior written authorization of Sun and its licensors, if any. Third-party software, including font technology, is copyrighted and licensed from Sun suppliers.

Parts of the product may be derived from Berkeley BSD systems, licensed from the University of California. UNIX is a registered trademark in the U.S. and other countries, exclusively licensed through X/Open Company, Ltd.

Sun, Sun Microsystems, the Sun logo, AnswerBook, AnswerBook2, docs.sun.com, Sun Enterprise, OpenBoot, JumpStart, Solstice SunNet Manager, Sun StorEdge, and Solaris are trademarks, registered trademarks, or service marks of Sun Microsystems, Inc. in the U.S. and other countries. All SPARC trademarks are used under license and are trademarks or registered trademarks of SPARC International, Inc. in the U.S. and other countries. Products bearing SPARC trademarks are based upon an architecture developed by Sun Microsystems, Inc.

The OPEN LOOK and Sun™ Graphical User Interface was developed by Sun Microsystems, Inc. for its users and licensees. Sun acknowledges the pioneering efforts of Xerox in researching and developing the concept of visual or graphical user interfaces for the computer industry. Sun holds a non-exclusive license from Xerox to the Xerox Graphical User Interface, which license also covers Sun's licensees who implement OPEN LOOK GUIs and otherwise comply with Sun's written license agreements.

Federal Acquisitions: Commercial Software—Government Users Subject to Standard License Terms and Conditions.

Sun Microsystems, Inc. has intellectual property rights relating to technology embodied in this product. In particular, and without limitation, these intellectual property rights may include one or more of the U.S. patents listed at <http://www.sun.com/patents> and one or more additional patents or pending patent applications in the U.S. and other countries.

DOCUMENTATION IS PROVIDED "AS IS" AND ALL EXPRESS OR IMPLIED CONDITIONS, REPRESENTATIONS AND WARRANTIES, INCLUDING ANY IMPLIED WARRANTY OF MERCHANTABILITY, FITNESS FOR A PARTICULAR PURPOSE OR NON-INFRINGEMENT, ARE DISCLAIMED, EXCEPT TO THE EXTENT THAT SUCH DISCLAIMERS ARE HELD TO BE LEGALLY INVALID.

Copyright 2001 Sun Microsystems, Inc., 901 San Antonio Road, Palo Alto, CA 94303-4900 Etats-Unis. Tous droits réservés.

Ce produit ou document est distribué avec des licences qui en restreignent l'utilisation, la copie, la distribution, et la décompilation. Aucune partie de ce produit ou document ne peut être reproduite sous aucune forme, par quelque moyen que ce soit, sans l'autorisation préalable et écrite de Sun et de ses bailleurs de licence, s'il y en a. Le logiciel détenu par des tiers, et qui comprend la technologie relative aux polices de caractères, est protégé par un copyright et licencié par des fournisseurs de Sun.

Des parties de ce produit pourront être dérivées des systèmes Berkeley BSD licenciés par l'Université de Californie. UNIX est une marque déposée aux Etats-Unis et dans d'autres pays et licenciée exclusivement par X/Open Company, Ltd.

Sun, Sun Microsystems, le logo Sun, AnswerBook, AnswerBook2, docs.sun.com, Sun Enterprise, OpenBoot, JumpStart, Solstice SunNet Manager, Sun StorEdge, et Solaris sont des marques de fabrique ou des marques déposées, ou marques de service, de Sun Microsystems, Inc. aux Etats-Unis et dans d'autres pays. Toutes les marques SPARC sont utilisées sous licence et sont des marques de fabrique ou des marques déposées de SPARC International, Inc. aux Etats-Unis et dans d'autres pays. Les produits portant les marques SPARC sont basés sur une architecture développée par Sun Microsystems, Inc.

L'interface d'utilisation graphique OPEN LOOK et Sun™ a été développée par Sun Microsystems, Inc. pour ses utilisateurs et licenciés. Sun reconnaît les efforts de pionniers de Xerox pour la recherche et le développement du concept des interfaces d'utilisation visuelle ou graphique pour l'industrie de l'informatique. Sun détient une licence non exclusive de Xerox sur l'interface d'utilisation graphique Xerox, cette licence couvrant également les licenciés de Sun qui mettent en place l'interface d'utilisation graphique OPEN LOOK et qui en outre se conforment aux licences écrites de Sun.

Sun Microsystems, Inc. a les droits de propriété intellectuels relatants à la technologie incorporée dans ce produit. En particulier, et sans la limitation, ces droits de propriété intellectuels peuvent inclure un ou plus des brevets américains énumérés à <http://www.sun.com/patents> et un ou les brevets plus supplémentaires ou les applications de brevet en attente dans les Etats - Unis et les autres pays.

LA DOCUMENTATION EST FOURNIE "EN L'ETAT" ET TOUTES AUTRES CONDITIONS, DECLARATIONS ET GARANTIES EXPRESSES OU TACITES SONT FORMELLEMENT EXCLUES, DANS LA MESURE AUTORISEE PAR LA LOI APPLICABLE, Y COMPRIS NOTAMMENT TOUTE GARANTIE IMPLICITE RELATIVE A LA QUALITE MARCHANDE, A L'APTITUDE A UNE UTILISATION PARTICULIERE OU A L'ABSENCE DE CONTREFAÇON.



Contents

- 1. Preparing for Installation 1-1**
 - 1.1 Unpacking and Preparing the System 1-2
 - 1.1.1 Shipping and Storing the System 1-3
 - 1.2 Preparing the Electrical Circuits 1-3
 - 1.3 Preparing the Air Conditioning 1-4
 - 1.4 Preparing the Ethernet Network 1-4
 - 1.5 Preparing the Area 1-6
 - 1.6 Using the User Naming Area 1-7

- 2. Cabling the System 2-1**
 - 2.1 Preparing the System for Cabling 2-1
 - 2.2 Installing the Fiber Cable Organizer 2-1
 - 2.3 Connecting the Power Cord 2-3
 - 2.4 Connecting the Network Cable to the System 2-5
 - 2.5 Connecting the System to the Network 2-6
 - 2.6 Connecting an ASCII Terminal 2-8
 - 2.7 Connecting the Fiber Cable to the I/O+ Board 2-10
 - 2.8 Connecting the Fiber Cable to the Interface Board and the I/O+ Board 2-12
 - 2.8.1 Wrapping the Fiber Cable on the Organizer 2-13
 - 2.9 Connecting External SCSI Devices 2-15

- 3. Powering the System On and Off 3-1**
 - 3.1 Using JumpStart Automatic Installation 3-1
 - 3.2 Powering On the System 3-2
 - 3.2.1 Reading Boot Messages 3-5
 - 3.2.2 Interpreting Status LED Patterns 3-6
 - 3.3 Powering Off the System 3-7

- 4. Software 4-1**
 - 4.1 Operating System Software and Patches 4-1
 - 4.1.1 Software Patches for Solaris Operating Environment and Sun StorEdge Products 4-2
 - 4.2 Sun™ Management Center Software 4-2
 - 4.3 Dynamic Reconfiguration for Hot-Pluggable System Boards 4-3
 - 4.4 CPU Over-Temperature Safeguard (COS) 4-3

- A. Regulatory Agency Compliance Statements A-1**
 - Index Index-1**

Figures

FIGURE 1-1	Enterprise 3500 System	1-2
FIGURE 1-2	Types of Network Cables Used	1-5
FIGURE 1-3	Example of 10/100BASE-T (Twisted-Pair) Ethernet	1-5
FIGURE 1-4	Enterprise 3500 Server Access Areas — Top View	1-7
FIGURE 2-1	Fiber Cable Organizer Mounted on Support Bracket	2-2
FIGURE 2-2	Key Switch Standby Position	2-3
FIGURE 2-3	AC Power Switch, AC Connector, and Retainer Clip	2-4
FIGURE 2-4	Network Cable	2-5
FIGURE 2-5	10/100BASE-T Ethernet Connection	2-6
FIGURE 2-6	Connecting Twisted Pair Ethernet to N-type Coaxial Cable	2-7
FIGURE 2-7	Ethernet Cabling Length — Example Using N-type Cable	2-8
FIGURE 2-8	Clock+ Board	2-9
FIGURE 2-9	Fiber Cable and Fiber Card Connectors and Ports on the I/O+ Board	2-11
FIGURE 2-10	Interface Board	2-12
FIGURE 2-11	Fiber Cable Ports on the Interface Board	2-13
FIGURE 2-12	Fiber Cable in “Figure 8” Pattern	2-14
FIGURE 2-13	Onboard Single-ended SCSI Connector on the I/O+ Board	2-16
FIGURE 3-1	Key Switch Positions	3-3
FIGURE 3-2	AC Power and Clock+ Board	3-4
FIGURE 3-3	CPU Reset Switch on Clock+ Board	3-5
FIGURE 3-4	System Status LED	3-6

Tables

TABLE P-1	Typographic Conventions	x
TABLE P-2	Shell Prompts	x
TABLE P-3	Related Documents	xi
TABLE 2-1	Ethernet Cabling Limitations for N-type Coaxial Cable	2-7
TABLE 2-2	GBIC Controllers for Disk Drive Ports	2-12
TABLE 2-3	Internal SCSI Lengths (Approximate)	2-15
TABLE 3-1	Front Panel LED System Status	3-7
TABLE 4-1	Enterprise 3500 Patch Support for Fibre Channel Internal Drives	4-2

Preface

The *Sun Enterprise™ 3500 System Installation Guide* provides installation instructions for the factory-configured 5-slot system. These instructions are for an experienced system administrator with networking knowledge.

Using UNIX Commands

This document may not contain information on basic UNIX® commands and procedures such as shutting down the system, booting the system, and configuring devices.

See one or more of the following for this information:

- *Solaris 2.x Operating Environment Handbook for SMCC Peripherals*, which contains Solaris™ Operating Environment software commands
- AnswerBook2™ online documentation for the Solaris operating environment software environment
- Other software documentation that you received with your system

Typographic Conventions

TABLE P-1 Typographic Conventions

Typeface	Meaning	Examples
AaBbCc123	The names of commands, files, and directories; on-screen computer output	Edit your <code>.login</code> file. Use <code>ls -a</code> to list all files. % You have mail.
AaBbCc123	What you type, when contrasted with on-screen computer output	% su Password:
<i>AaBbCc123</i>	Book titles, new words or terms, words to be emphasized	Read Chapter 6 in the <i>User's Guide</i> . These are called <i>class</i> options. You <i>must</i> be superuser to do this.
	Command-line variable; replace with a real name or value	To delete a file, type <code>rm filename</code> .

Shell Prompts

TABLE P-2 Shell Prompts

Shell	Prompt
C shell	<i>machine_name</i> %
C shell superuser	<i>machine_name</i> #
Bourne shell and Korn shell	\$
Bourne shell and Korn shell superuser	#

Related Documentation

TABLE P-3 Related Documents

Application	Title	Part Number
Service	<i>Sun Enterprise 3500 System Reference Manual</i>	805-2630
Software	<i>SMCC SPARC Hardware Platform Guide</i>	802-5341
	<i>Sun Management Center User's Guide</i>	802-5355
	<i>Dynamic Reconfiguration User's Guide for Sun Enterprise Systems</i>	805-3530
Options	<i>Sun Enterprise Expansion Cabinet Installation and Service Manual</i>	805-4009
	<i>Sun Enterprise 6/5/4/3x00 Board Installation Guide</i>	805-4007
	<i>4 Mbyte UltraSPARC II Installation Guide</i>	805-1150
	<i>Sun Enterprise xx00 Systems CPU Module Installation for 400-MHz 8-Mbyte CPU Module</i>	806-0960
	<i>Sun Enterprise xx00 Systems CPU Module Installation for 464-MHz 8-Mbyte CPU Module</i>	816-1994
	<i>Sun Enterprise 6/5/4/3x00 Systems DIMM Installation Guide</i>	802-5032
	<i>SBus+ and Graphics+ I/O Boards (100 MB/sec Fibre Channels) for Sun Enterprise 6/5/4/3x00 Systems</i>	805-2704
	<i>PCI+ I/O Board Installation and Component Replacement for Sun Enterprise 6/5/4/3x00 Systems</i>	805-1372
	<i>Sun Enterprise Peripheral Power Supply/AC Installation Guide</i>	802-5033
	<i>Sun Enterprise 3500 Auxiliary Peripheral Power Supply Installation Guide</i>	805-4012
	<i>Sun Enterprise 3500 Fiber Cable Organizer Installation Guide</i>	805-4010
	<i>Sun Enterprise 3500 Interface Board Installation Guide</i>	805-4011
	<i>Sun Enterprise Peripheral Power Supply Installation Guide</i>	802-5033
<i>Sun Enterprise Power/Cooling Module (PCM) Installation Guide</i>	802-6244	
<i>Sun Enterprise 6x00/5x00/4x00/3x00 Capacity-on-Demand (COD) Building Blocks User's Guide</i>	806-4592	
	<i>Rackmount Placement Matrix web site at docs.sun.com</i>	

Accessing Sun Documentation Online

A broad selection of Sun system documentation is located at the following web site:

<http://www.sun.com/products-n-solutions/hardware/docs>

To locate the most current documentation at this site, select a product category. The documents at that location may include updated information that did not ship with your product, such as product notes, release notes, late-breaking news, or later revisions of manuals.

Ordering Sun Documentation

Fatbrain.com, an Internet professional bookstore, stocks select product documentation from Sun Microsystems, Inc.

For a list of documents and how to order them, visit the Sun Documentation Center on Fatbrain.com at:

<http://www.fatbrain.com/documentation/sun>

Sun Welcomes Your Comments

Sun is interested in improving its documentation and welcomes your comments and suggestions. You can email your comments to Sun at:

docfeedback@sun.com

Please include the part number (805-2630-10) of your document in the subject line of your email.

Notes, Cautions, and Warnings



Caution – This equipment contains lethal voltage. Accidental contact with centerplane, card cage, and drive areas can result in serious injury or death.



Caution – Improper handling by unqualified personnel can cause serious damage to this equipment. Unqualified personnel who tamper with this equipment may be held liable for any resultant damage to the equipment.

Individuals who remove any outer panels or open covers to access this equipment must observe all safety precautions and ensure compliance with skill level requirements, certification, and all applicable local and national laws.

Procedures contained in this document must be performed by qualified service-trained maintenance providers.

Note – Before you begin, carefully read each of the procedures in this manual. If you have not performed similar operations on comparable equipment, *do not attempt* to perform these procedures.

Preparing for Installation

This chapter describes how to prepare your site for the Sun Enterprise 3500 System.

The tasks for installing the system are:

- Unpacking the system on page 1-2
- Preparing the system on page 1-2
- Preparing the site on page 1-6
- Cabling on page 2-1
- Powering on page 3-1
- Using the software on page 4-1

Note – For information about physical specifications, electrical specifications, and environmental requirements, refer to Appendix A “Specifications,” in the *Sun Enterprise 3500 System Reference Manual* (part number 805-2630).

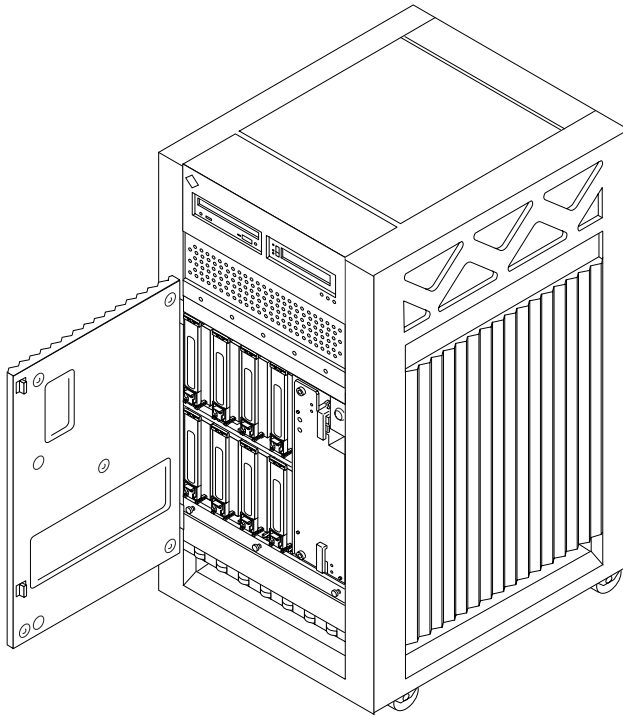

FIGURE 1-1 Enterprise 3500 System

1.1 Unpacking and Preparing the System

Note – Inspect all shipping cartons for evidence of physical damage. If a shipping carton is damaged, request that the carrier’s agent be present when the carton is opened. Keep all contents and packing material for the agent’s inspection.

If the system is already unpacked, go to Section 1.2 “Preparing the Electrical Circuits.”



Caution – The system can weigh up to 185 lbs (84 kg). To prevent personal injury, two people are needed to lift the system safely. The rear support bracket is designed to support the system weight only when the system is stationary, on a flat surface. Do not attempt to lift the system by grasping the support bracket.

Tools

- No. 2 Phillips screwdriver
- System key for front door and key switch (packed in a bag in the accessory box)

Follow the graphical instructions on the shipping container to remove the system from the container. Remove the system key (for front door and key switch), and power cord from the shipping container. These are needed to power on the system.

Note – Any unpacking instructions printed on the outside of the shipping carton take precedence over information in this section.

1.1.1 Shipping and Storing the System

Save the original shipping containers and packing materials in case you need to store or ship your system.

If you cannot store the shipping materials, recycle or dispose of these materials properly. Consult your local recycling authority for information.

1.2 Preparing the Electrical Circuits

In planning where to place your equipment, remember that each of the following items requires access (by way of a separate power cord) to a power outlet:

- Enterprise 3500 system
- External peripherals
- Monitor used for diagnostics

The Enterprise 3500 system uses nominal input voltages of 100-120 VAC or 200-220 VAC. Sun products are designed to work with single-phase power systems that have a grounded neutral conductor.

To reduce the risk of electrical shock, do not connect Sun products into another type of power source. Contact your facilities manager or a qualified electrician if you are unsure what type of power is supplied to your building.

1.3 Preparing the Air Conditioning

For the most reliable system operation:

- The room should have sufficient air conditioning capacity to support the cooling needs of the entire system.
- The air conditioning system should have controls that prevent excessive temperature changes.

Refer to Appendix A “Specifications,” in the *Sun Enterprise 3500 System Reference Manual* for environmental information.

1.4 Preparing the Ethernet Network

The Enterprise 3500 system follows the IEEE standard for 10/100BASE-T Ethernet (twisted-pair) or MII (Media Independent Interface).

Twisted-pair cables used with Sun Microsystems™ products have RJ-45 connectors that resemble the smaller RJ-11 connectors used for modular telephone cables. For twisted-pair cable length, see Chapter 2, TABLE 2-1 on page 2-7.

A MII to AUI converter cable, available from Sun, enables the 10/100 Mbps Ethernet interface to run over 10 Mbps coaxial Ethernet networks. Other MII Ethernet connectivity products are available from third parties.

FIGURE 1-2 and FIGURE 1-3 illustrate types of network cables and possible implementations of 10/100BASE-T Ethernet.

Set up the network using Sun or third-party components. To obtain the best results, read any applicable manufacturer instructions. Be aware that Sun Microsystems cannot guarantee the performance of any components that are not purchased from Sun.

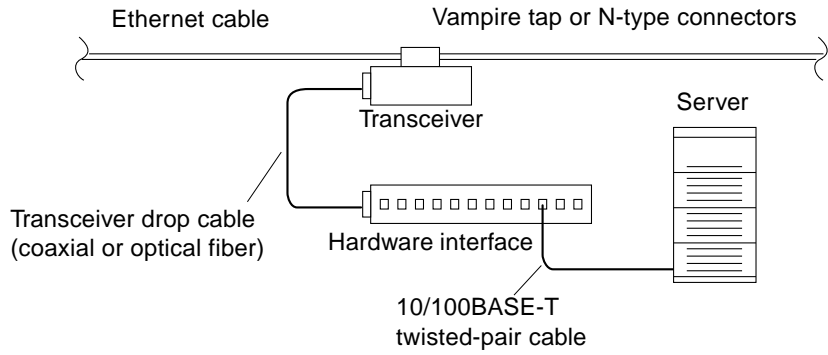

FIGURE 1-2 Types of Network Cables Used

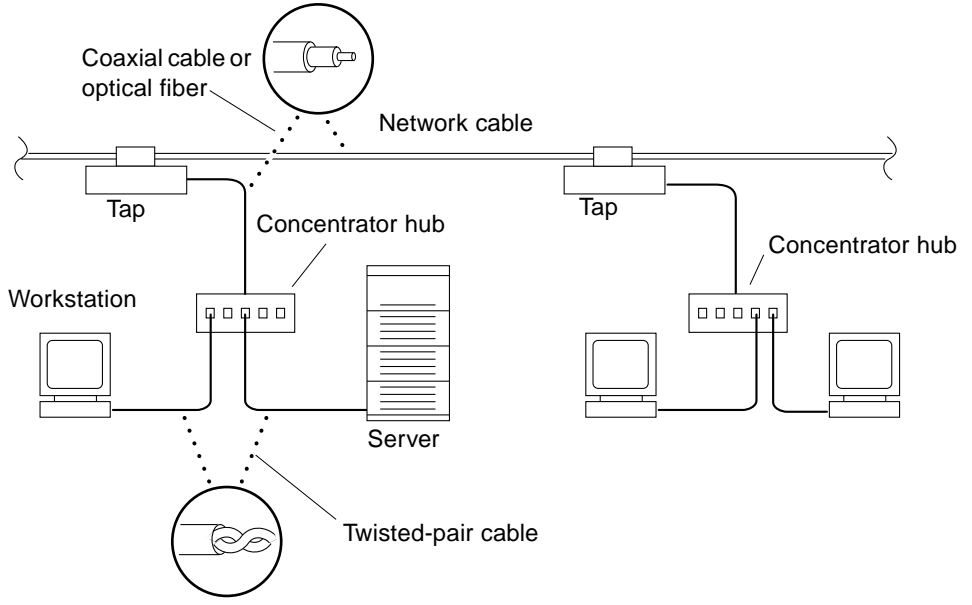

FIGURE 1-3 Example of 10/100BASE-T (Twisted-Pair) Ethernet

Note – Multiplexer boxes require a transceiver when used with the Ethernet applications described in this manual. Although these transceivers are compatible with Sun equipment, Sun Microsystems does not guarantee the performance of any component that was not purchased from Sun.

Many transceivers are compatible with both level-1 and level-2 Ethernet. To operate these transceivers with Sun equipment, set the device for level-2 operation following the manufacturer's instructions.

Sun equipment conforms to the Ethernet 10/100BASE-T standard, which states that the 10/100BASE-T Link Integrity Test function should always be enabled on both the host and the hub. If you have problems verifying connection between Sun equipment and your hub, verify that your hub also has the link test function enabled. Refer to Section 9.6.1, "Failure of Network Communications," in the *Sun Enterprise 3500 System Reference Manual* (part number 805-2630), and refer to the manual provided with your hub.

Refer to the *Sun Microsystems Data Center Site Planning Guide, Data Centers' Best Practices* (805-5863) or the *Thermal Guidelines for Mounting Sun Products in a Non-Sun Cabinet* (805-1454) for more information on the recommended optimal operating environment.

1.5 Preparing the Area

Use the following guidelines to prepare a location for your server.

- The server unit requires approximately 1.5 feet (47 cm) of space in the front and rear for access by service personnel (FIGURE 1-4).
- A minimum space of 6 inches (16 cm) is required on both sides of the server to afford adequate air flow.



Caution – To avoid exhaust air recirculation, do not place the systems or peripherals next to each other, side by side.

- Keep power and interface cables clear of foot traffic. Route cables inside walls, under the floor, through the ceiling, or in protective channels. Route interface cables away from motors and other sources of magnetic or radio frequency interference.

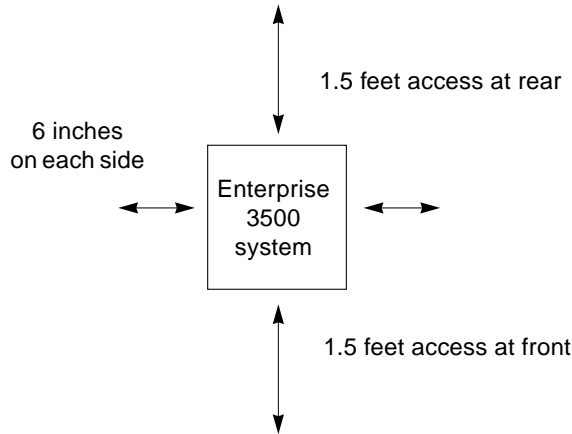

FIGURE 1-4 Enterprise 3500 Server Access Areas — Top View

1.6 Using the User Naming Area

To display the name of the server, IP address, owner, or other important information on the front of the machine:

1. Remove the front bezel.

Refer to Chapter 12 “Preparing for Service,” in the *Sun Enterprise 3500 System Reference Manual* (Section 12.3.1 “Front Bezel”).

2. Snap out the narrow transparent window.

From the rear side of the bezel, gently squeeze the top and bottom edges together as you simultaneously push the transparent window out through the front of the bezel.

3. Choose the information that will appear on the label.

Common items include the name of the server, IP address, name and contact information for the system administrator, and the group of users that the machine services.

4. Use the colored paper provided with the system to make a label.

The available area for the paper label is 0.5 in x 5.9 in (12 mm x 150 mm). Print or write the desired information in an area this size and cut the label to fit the transparent window.

5. Place the paper label inside the window, and snap the window back in place from the front side of the bezel.

Cabling the System

This chapter contains instructions for installing the fiber cable organizer, cabling the system, and connecting the power cord to the AC power supply.

2.1 Preparing the System for Cabling

Make sure the server is in an area that allows access to the front and rear of the chassis. This site should conform to site preparation guidelines and specifications covered in Chapter 1.

2.2 Installing the Fiber Cable Organizer

Use the fiber cable organizer to route the fiber optic cable to connect the interface board and the I/O+ board. A 2-meter cable is required when utilizing the internal FC-AL disk drives. The cable organizer can help prevent damage to the fiber optic cable by helping ensure the 1.0 inch minimum bend radius rule is observed.

The fiber cable organizer kit includes two organizer sections and one screw. To install the cable organizer:

- 1. Remove the screw securing the power cord retainer clip to the support bracket at the rear of the system.**
- 2. Orient one of the fiber cable organizer sections with the spool facing toward you. Set the hooks on the back of the organizer into the corresponding cutouts on the right side of the support bracket.**

The top of the brace should be flush with the top of the support bracket. The organizer will extend below the bracket.

3. **Secure the organizer by pushing it outward along the support bracket until the snap at the rear of the organizer clicks audibly into place.**
4. **Install the left spool brace by repeating Step 2 and Step 3.**
5. **Using the screw included in the kit, fasten the spool braces to the support bracket through the center front cut out formed when both braces are in place.**
6. **Remount the retainer clip through the hex nut at the notch on the side of the organizer.**
Set the retainer clip screw into the hex nut.
7. **To wrap the 2-meter fiber cable around the organizer spools to interconnect the interface board and the I/O+ board for FC-AL disks, see Section 2.8.1 “Wrapping the Fiber Cable on the Organizer” on page 2-13.**

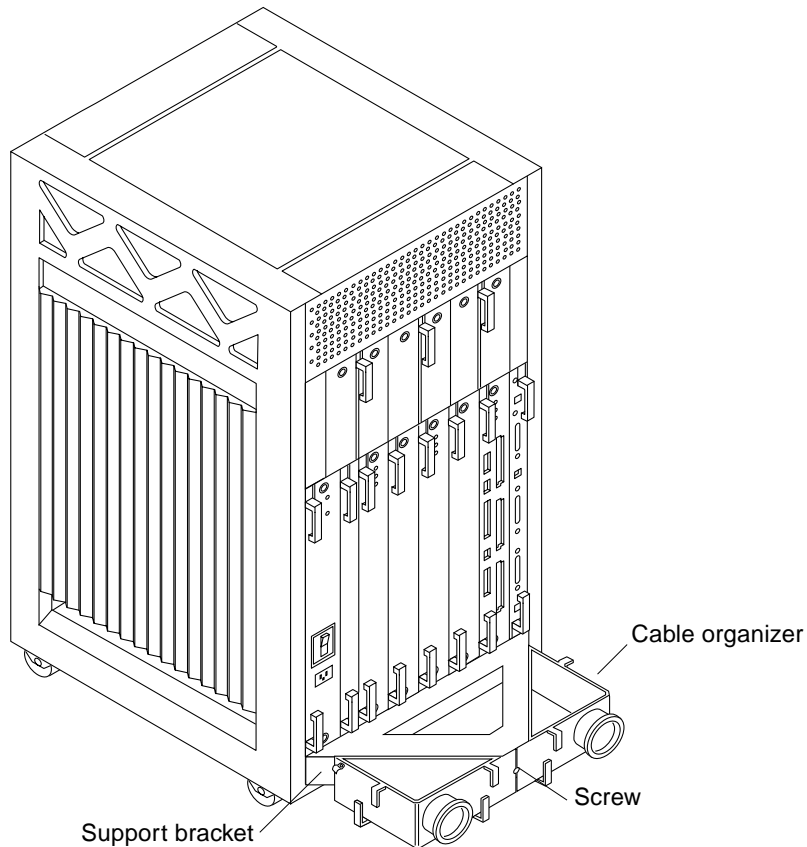



FIGURE 2-1 Fiber Cable Organizer Mounted on Support Bracket

2.3 Connecting the Power Cord

1. Use the key provided with your system to unlock and open the Enterprise 3500 system front door.
2. Locate the system key switch in the upper right corner, insert the key provided, and turn the key switch to  (the Standby position) (FIGURE 2-2).

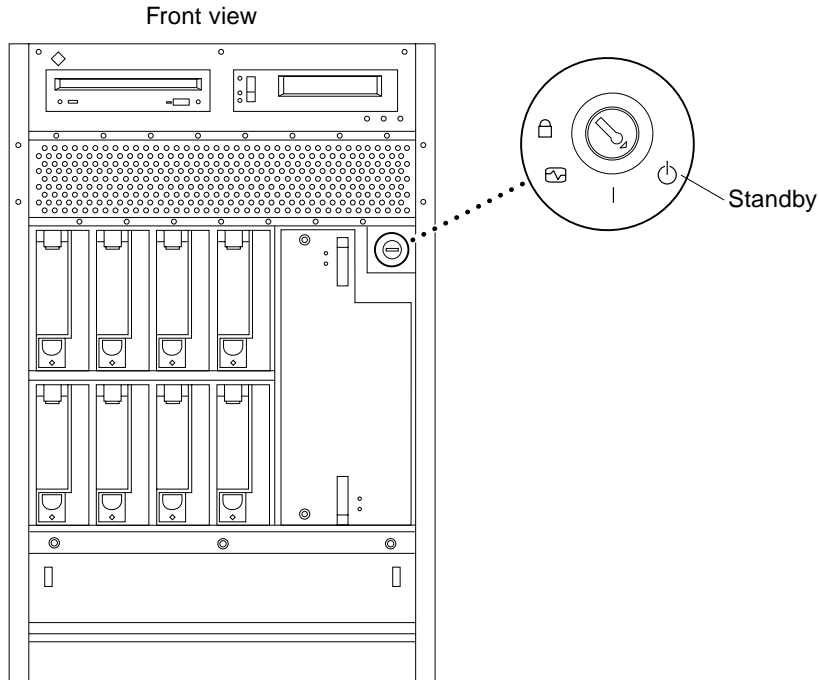

FIGURE 2-2 Key Switch Standby Position

3. Turn the AC power switch to Off.
This switch is at the rear of the system, on the peripheral power supply/AC (PPS/AC) that is installed in the far left corner (FIGURE 2-3).
4. Connect the female end of the power cord into the AC connector.
This connector is at the rear of the system, on the PPS/AC, just below the AC power switch (FIGURE 2-3).

5. Route the power cord through the power cord retainer clip.

In Step 6 of “Installing the Fiber Cable Organizer,” you reattached the plastic clip to the cable organizer that you mounted on the rear support bracket (FIGURE 2-3).

a. Use a Phillips screwdriver to open the plastic retainer clip and remove the screw.

b. Place the power cord inside the open retainer clip and replace the screw to close the clip.

6. Connect the male end of the power cord into a grounded outlet.

The outlet must be a 100-120 or 220-240 VAC 15A circuit.

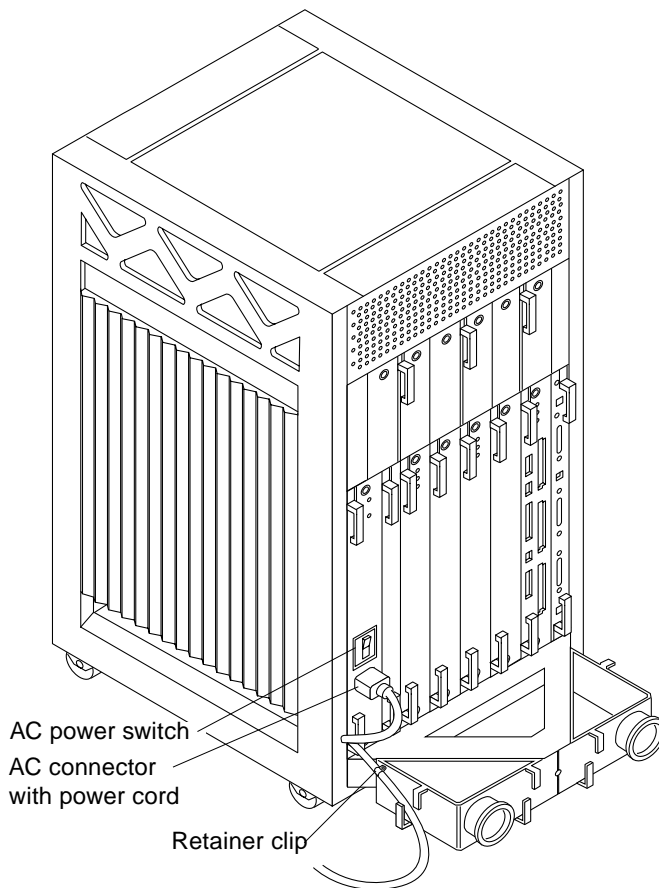

FIGURE 2-3 AC Power Switch, AC Connector, and Retainer Clip



Caution – Do NOT turn on power to the unit yet. Doing so can cause system damage to occur.

7. Continue with Section 2.3 and Section 2.4 to connect the system to the network. See Sections 2.5 through 2.7 for further cabling instructions.

2.4 Connecting the Network Cable to the System

The locations specified in the following instructions assume the use of twisted-pair.

1. Locate the network cable.

FIGURE 2-4 shows the twisted-pair Ethernet network cable.

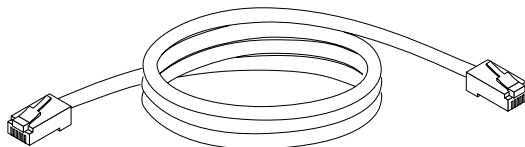

FIGURE 2-4 Network Cable

2. Connect one end of the network cable into the RJ-45 twisted-pair network port. For 10/100BASE-T Ethernet, the default interface port is the onboard connector on the I/O+ board in slot 1 (FIGURE 2-5).

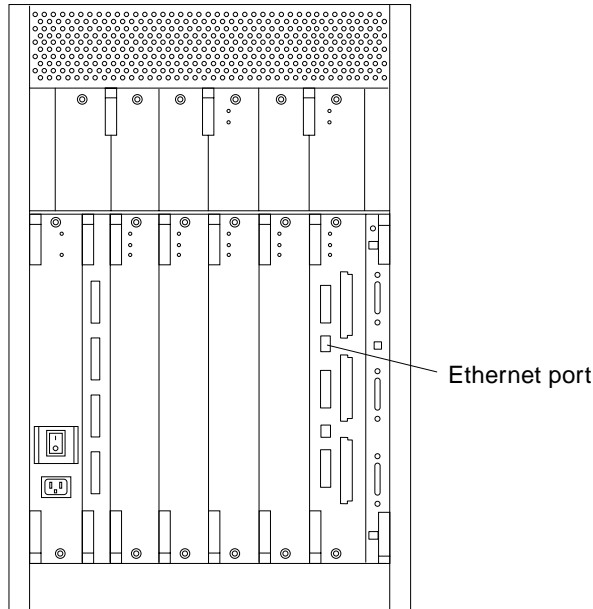

FIGURE 2-5 10/100BASE-T Ethernet Connection

2.5 Connecting the System to the Network

1. **Connect the network cable to a twisted-pair-to-transceiver interface box.**
2. **Connect the interface box with an appropriate cable to a network transceiver.**
 FIGURE 2-6 shows a typical arrangement for connecting the system to an Ethernet network.
3. **For Ethernet cables, determine if the cable has N-type screw-on connectors at the ends.**
 - If the Ethernet cable lacks N-type connectors at the ends, use a “vampire” tap to connect the cable to the transceiver (FIGURE 2-6). To connect the cable to the transceiver, use instructions provided with the “vampire” tap.
 - If the Ethernet cable has N-type connectors, connect the Ethernet cable to the transceiver:
 - a. **Screw the Ethernet coaxial cable into one of the round screw-on type connectors on the transceiver.**
 Use either one of the transceiver connectors.

b. Screw the other Ethernet coaxial cable into the other round screw-on type connector on the transceiver.

4. Determine if a terminator should be installed.

TABLE 2-1 lists the cabling limitations for Ethernet.

5. If termination is required, install a 50-ohm terminator in the unused transceiver N connector or at the end of the coaxial cable.

Use a female double N-type connector.

FIGURE 2-6 shows the elements used in the installation process.

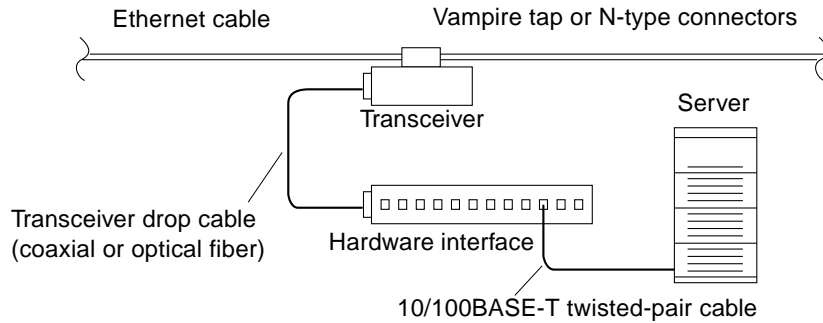

FIGURE 2-6 Connecting Twisted Pair Ethernet to N-type Coaxial Cable

TABLE 2-1 lists the cabling limitations for Ethernet.

TABLE 2-1 Ethernet Cabling Limitations for N-type Coaxial Cable

Cable Segment	Length in Meters
Allowed contiguous length of cable segments	23.4
	70.2
	117.0
	500.0 ¹
Distance between transceivers (multiples-of)	2.5 ²
Minimum length of Ethernet coaxial cable segments	23.4
Maximum length of transceiver “drop” cable	50.0
Minimum length of twisted pair cable	no minimum
Maximum length of twisted pair cable	110

1. Finite lengths (as constrained by transmission line phenomena). Minimum length = 23.4M; maximum = 500M. If cable falls shorter than one of these values, add cable to achieve next-highest value.

2. Transceivers are placed at intervals of 2.5 meters, or multiples of 2.5 meters along the Ethernet cable.
 Example: transceivers are connected 2.5 meters apart, not 2.0 meters.
 Example: transceivers are connected 15 meters apart (6 multiples of 2.5 meters), not 14.0 meters.

FIGURE 2-7 shows an example of a typical network setup. The Enterprise 3500 system can be any server shown in this figure.

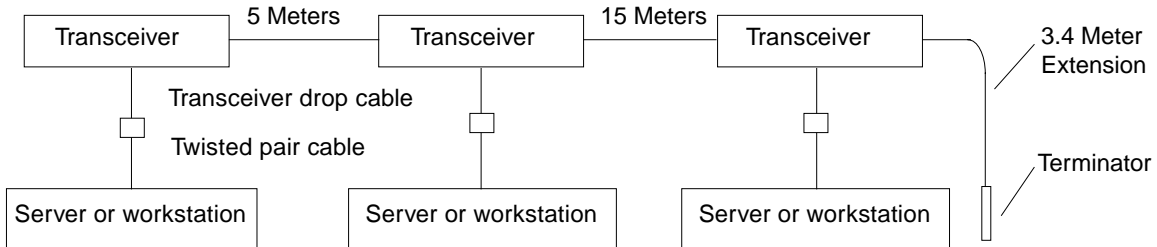

Note: 5 Meters + 15 Meters + 3.4 Meter Extension = 23.4 Meters minimum length allowed.

FIGURE 2-7 Ethernet Cabling Length — Example Using N-type Cable

Note – Sun equipment conforms to the Ethernet 10/100BASE-T standard, which states that the 10/100BASE-T Link Integrity Test function should always be enabled on both the host and the hub. If you have problems verifying connection between Sun equipment and your hub, verify that your hub also has the link test function enabled. Refer to Section 8.6.1, “Failure of Network Communications,” in the *Sun Enterprise 3500 System Reference Manual* (part number 805-2630), and refer to the manual provided with your hub for more information about the Link Integrity Test function.

6. If all cables are connected, power on the system.

2.6 Connecting an ASCII Terminal

An ASCII terminal (or workstation) can be attached to the server to display diagnostic messages produced by the firmware (power-on self-test/POST or OpenBoot™ PROM/OBP) program. A terminal is not required for normal server operations, so it may be necessary to locate a terminal to connect to the server.

1. Connect the terminal cable into serial port A on the clock+ board (FIGURE 2-8).

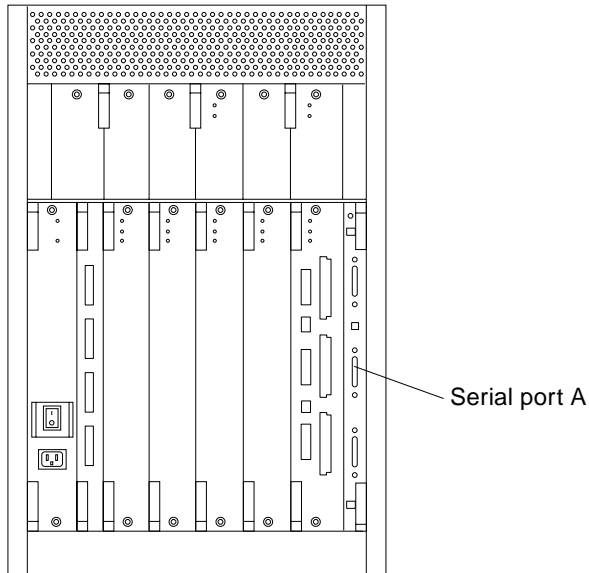

FIGURE 2-8 Clock+ Board

2. Connect the terminal power cord into an AC wall outlet.
3. Configure the ASCII terminal as follows:
 - 9600 bps
 - 1 stop bit
 - 8 data bits
 - Parity off
 - Full duplex

Refer to the instruction manual shipped with the terminal for specific configuration instructions.

Note – The setup parameters listed in Step 3 may differ from the setup at the customer site. These parameters can be changed in the nonvolatile random access memory (NVRAM). Refer to the `set-defaults` and `printenv` commands in the *OpenBoot Command Reference* manual, part number 802-3242.

2.7 Connecting the Fiber Cable to the I/O+ Board

1. **Remove the two plastic caps that cover the cable connector on the GBIC module.**
2. **Remove the plastic cap covering the ends of the fiber cable.**
3. **Connect one end of the fiber cable into the GBIC module installed on the I/O+ board.**

Align the notch in the cable connector with the key notch in the module connector (FIGURE 2-9).

4. **Connect the other end of the fiber cable into the GBIC connector on the SPARCstorage™ Array (or other storage device with fiber optic interface) rear panel.**

Align the notch in the cable connector with the notch in the connector on the storage device rear panel.

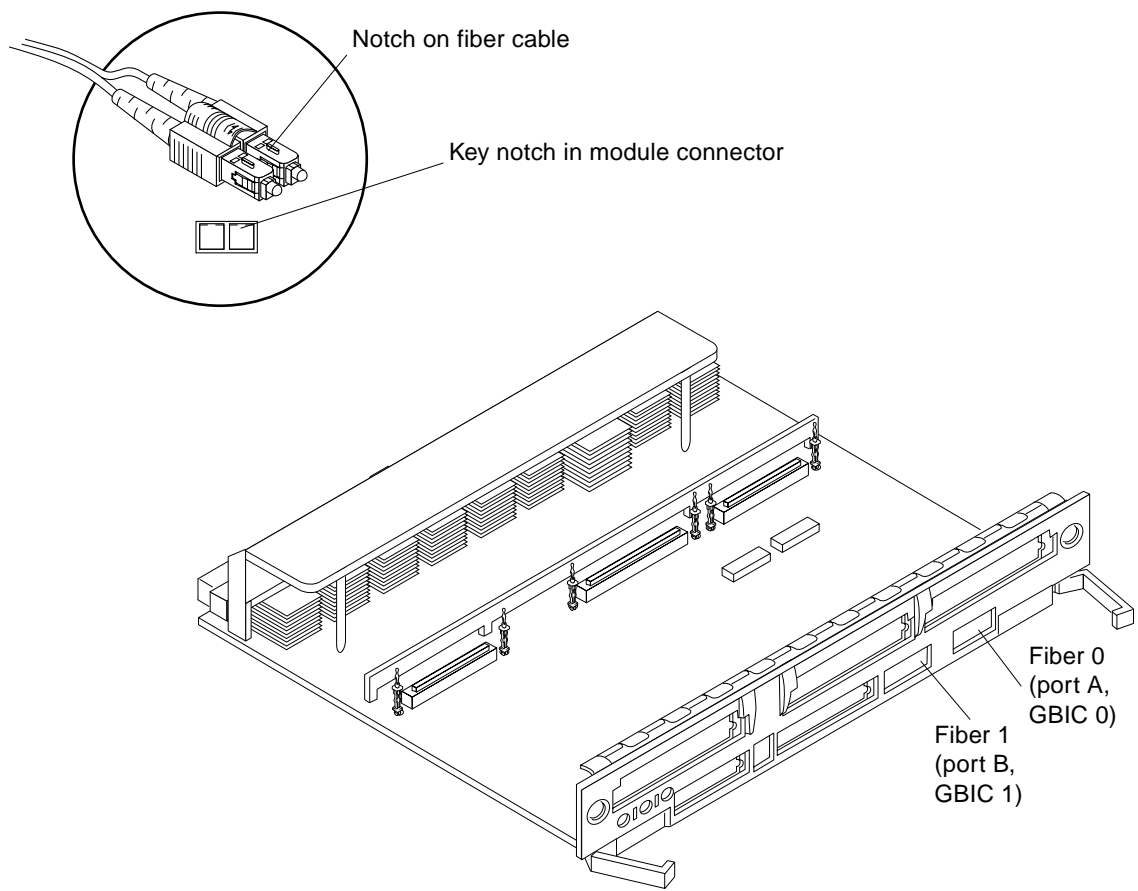

FIGURE 2-9 Fiber Cable and Fiber Card Connectors and Ports on the I/O+ Board

2.8 Connecting the Fiber Cable to the Interface Board and the I/O+ Board

Internal FC-AL disk drives require an interface board (IB) to communicate via the I/O+ board. FIGURE 2-10 identifies the GBIC ports on the interface board, and TABLE 2-2 identifies the GBIC associated with each disk drive.

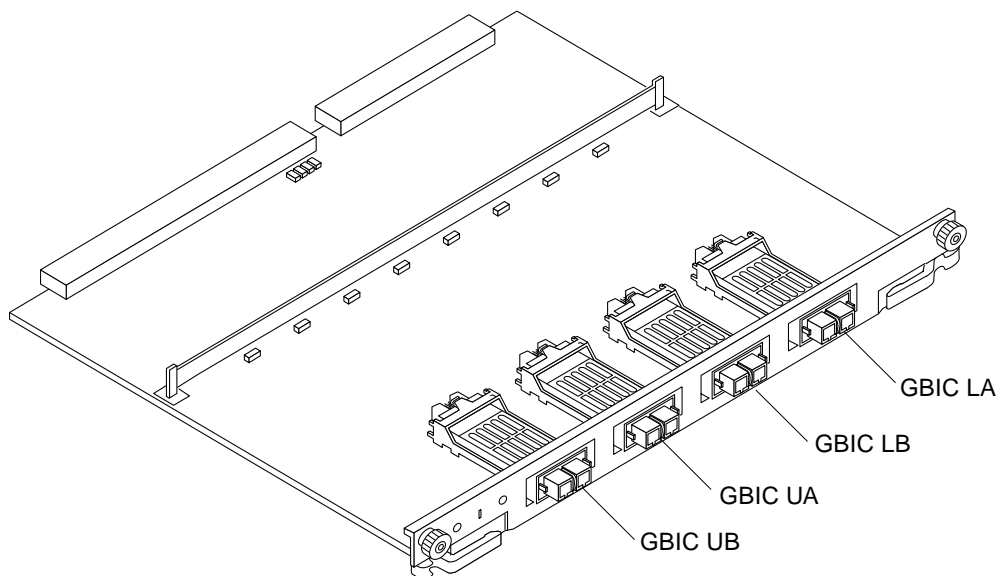

FIGURE 2-10 Interface Board

TABLE 2-2 GBIC Controllers for Disk Drive Ports

Disk Drives	Drive Port	GBIC Name and Location
0, 1, 2, 3	A	GBIC LA (Lower bank)
0, 1, 2, 3	B	GBIC LB (Lower bank)
4, 5, 6, 7	A	GBIC UA (Upper bank)
4, 5, 6, 7	B	GBIC UB (Upper bank)

Note – Reserve disk bay 0 for the boot disk.

2.8.1 Wrapping the Fiber Cable on the Organizer

To ensure that the fiber optic cable minimum bend radius rule (1.0 inch) is observed, use this procedure to wrap the cable around the spool organizer:

1. Remove the two plastic caps that cover the cable connector on the GBIC module.
2. Remove the plastic cap covering the ends of the fiber cable.
3. Connect one end of the fiber cable into the GBIC module installed on the interface board rear panel.

Use the IB diagram and GBIC controllers table on page 2-12 to identify the GBIC for the disk drive.

Align the notch in the cable connector with the key notch in the GBIC module connector (FIGURE 2-11).

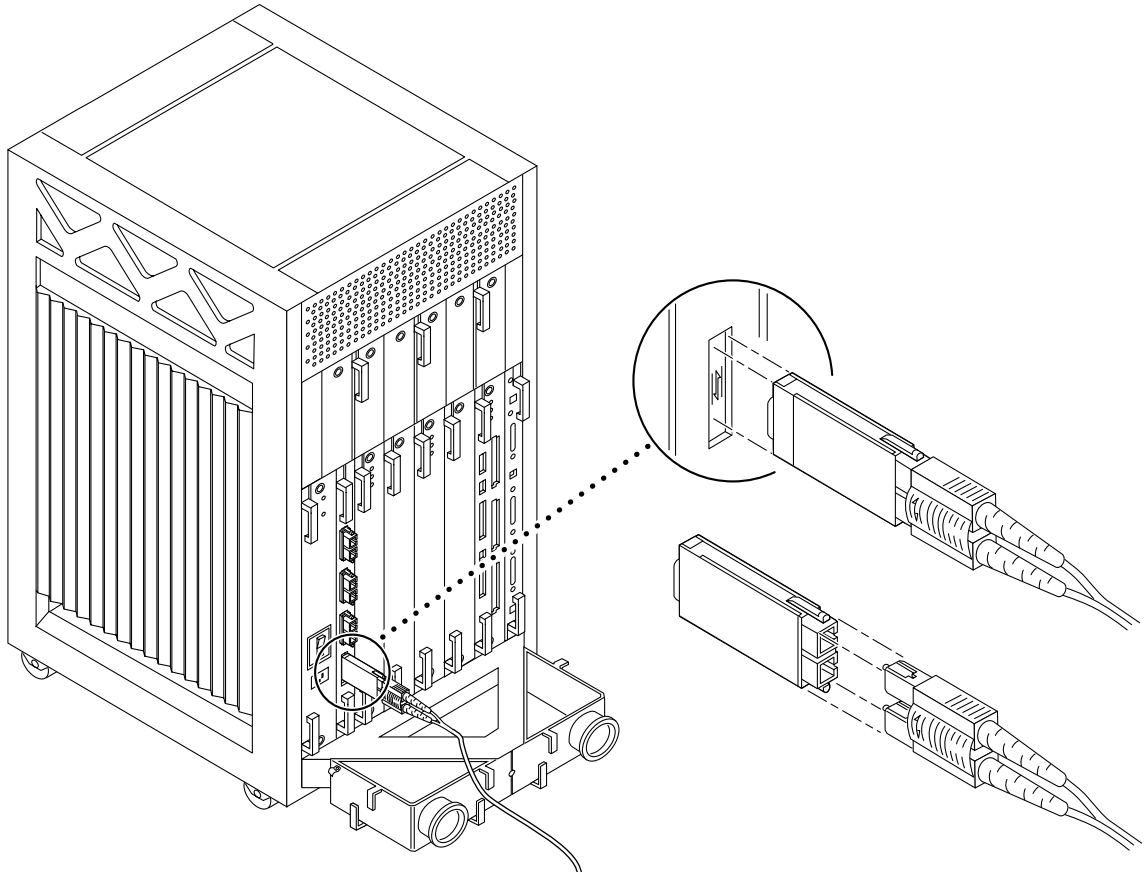

FIGURE 2-11 Fiber Cable Ports on the Interface Board

4. Route the fiber cable toward the bottom of the system, placing it through the left side restraints on the organizer.
5. Wrap the cable around the fiber cable organizer spools (mounted on the system rear support bracket) in a “figure 8” pattern (FIGURE 2-12)
 - a. Wrap the cable around the bottom of the left spool and then up and around the right spool, threading the cable through the center restraints on the organizer.
 - b. Thread the cable back through the center restraints, then down and around the left spool.

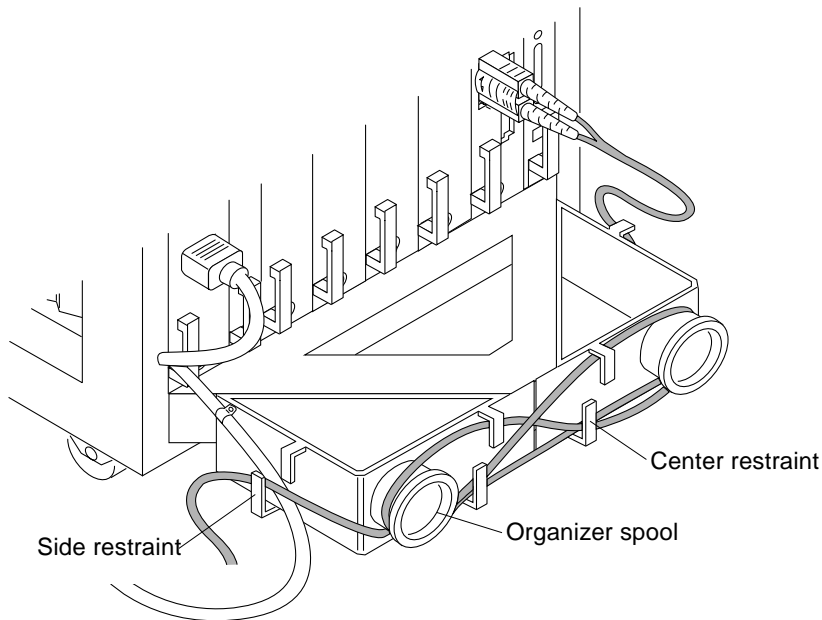

FIGURE 2-12 Fiber Cable in “Figure 8” Pattern

6. Repeat Step 5 until the cable is the desired length, finishing on the right side.
7. Thread the cable through the right side restraints and connect it to the I/O+ board.

2.9 Connecting External SCSI Devices

External SCSI-2 devices connect to your system through the built-in single-ended Fast/Wide SCSI-2 port on I/O+ boards (except for the board in slot 1), or through FSBE/S, DSBE/S, SWIS/S, or DWIS/S SBus cards installed on I/O+ boards.

Note – The onboard SCSI-2 bus on the I/O+ board in slot 1 controls internal media tray devices. Therefore, the external SCSI connector on the I/O+ board in slot 1 must always have a terminator installed.

Note – The maximum combined length for a string of SCSI cables is 6 meters for non-differential cables. For differential SCSI cables, the maximum is 25 meters. When calculating the total length of a SCSI string, include external cables, internal cables, and printed traces. TABLE 2-3 lists internal measurements for the Enterprise servers.

TABLE 2-3 Internal SCSI Lengths (Approximate)

Location	Internal Length
SBus+ I/O board	0.43 meter
Graphics+ I/O board	0.43 meter

For information on device addressing, priorities, and slot assignments, refer to Appendix D, “Rules for System Configuration” in the *Sun Enterprise 3500 System Reference Manual*, part number 805-2630.



Caution – Do not assign the same SCSI address to two devices sharing the same SCSI bus or SBus card. This step can result in equipment damage.

To connect an external SCSI device to your system:

1. Connect a SCSI cable to the appropriate SCSI-2 host on the I/O+ board.

- For the I/O+ board in slot 1, this is an SBus card installed in an appropriate SBus slot.
- For I/O+ boards in slots 2 through 5, use the onboard SCSI-2 port or an SBus card installed in an appropriate SBus slot.

FIGURE 2-13 shows the location of the onboard single-ended SCSI connector on the I/O+ board.

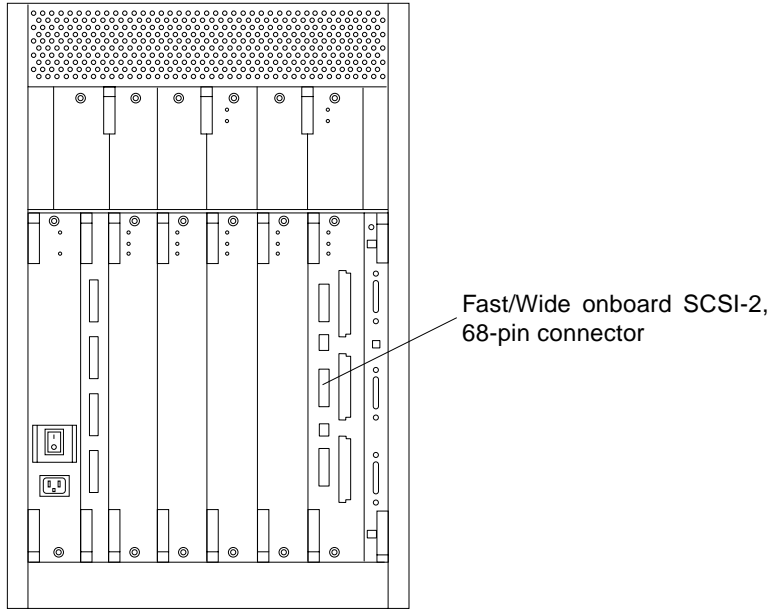

FIGURE 2-13 Onboard Single-ended SCSI Connector on the I/O+ Board

- 2. Connect the other end of the SCSI cable to the external SCSI-2 device.**
- 3. Power on the system and test the server.**

Powering the System On and Off

This chapter contains information about powering the system on and off, reading boot messages, and interpreting system status by viewing the LEDs.

3.1 Using JumpStart Automatic Installation

The Enterprise 3500 system can use the JumpStart™ automatic installation feature that is described in installation documents for Solaris software. The software that enables this feature is present on a hard disk in your system if the system was built at the factory with internal disk boards or disk trays.

JumpStart will run only when the system is powered on for the first time.



Caution – JumpStart may incorrectly install the system as a standalone workstation. You should prevent JumpStart automatic installation from proceeding if the appropriate server-specific configuration information is not in place. Information about the JumpStart feature is on a card titled “JumpStart Installation Instructions” that is provided with the system documentation.

To prevent JumpStart installation from occurring unintentionally:

- Do not connect the system to a network when you power it on initially.
- Do not place a Solaris software release DVD-ROM in a drive when you first power on the machine.

Note – If JumpStart automatic installation begins unintentionally, interrupt it by pressing L1-A (Stop-A) or Break (on TTYa). Perform a manual installation when you are ready.

If JumpStart completes the installation incorrectly, you may need to reinstall the Solaris Operating Environment manually.

3.2 Powering On the System

Note – It is advisable to connect an ASCII terminal to the system during installation. See Section 2.6 “Connecting an ASCII Terminal,” for terminal settings and connections.

Observe the yellow (middle) LED on the front panel. It should go off when the boot process completes. If it remains lit, observe the terminal screen for boot messages produced by the firmware diagnostic program during power on.

To power on the Enterprise 3500 system:

1. **Begin with a safety inspection of the system.**
 - a. **Use the key provided to unlock and open the system front door.**
 - b. **Turn the system key switch to ϕ (the Standby position).**
 - c. **Turn the AC power sequencer power switch to Off.**

The AC power sequencer is at the rear of the enclosure (FIGURE 3-2).
 - d. **Verify that the AC power cord is connected to a power outlet.**



Caution – Do not disconnect the power cord from the wall socket when working on the server. This connection provides a ground path that prevents damage from uncontrolled electrostatic discharge.

2. **Turn on power to any expansion cabinets.**

Read the documentation supplied with each type of expansion cabinet for specific instructions.
3. **Turn on the terminal (if applicable).**
4. **Turn the AC power sequencer power switch to On (FIGURE 3-2).**
5. **Turn the key switch to the On position (FIGURE 3-1).**

You should see and hear several things happen:

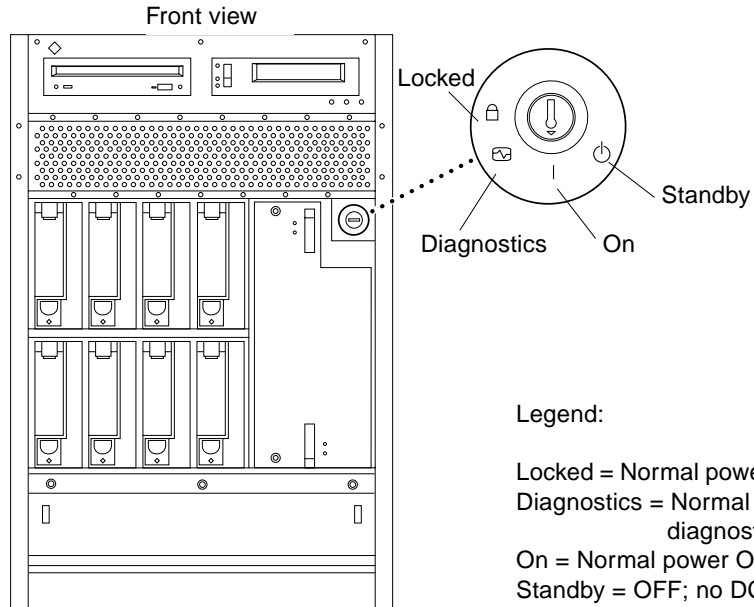

FIGURE 3-1 Key Switch Positions

- The fans in the power supplies begin turning.
- The left front panel LED (green) turns on immediately denoting that the power supply is delivering DC power.
- The middle front panel LED (yellow) flashes while POST runs for approximately 60 seconds. After 60 seconds, this LED turns off if the tests pass. If the LED remains lit after 60 seconds, a test has failed.
- The right front panel LED (green) flashes to show that boot is successful and the operating system is running. If this LED fails to turn on and the middle LED is on, a severe hardware fault exists.



Caution – Never move the system when the power is on. Doing so may result in catastrophic disk drive failure. Always power the system off before moving it.

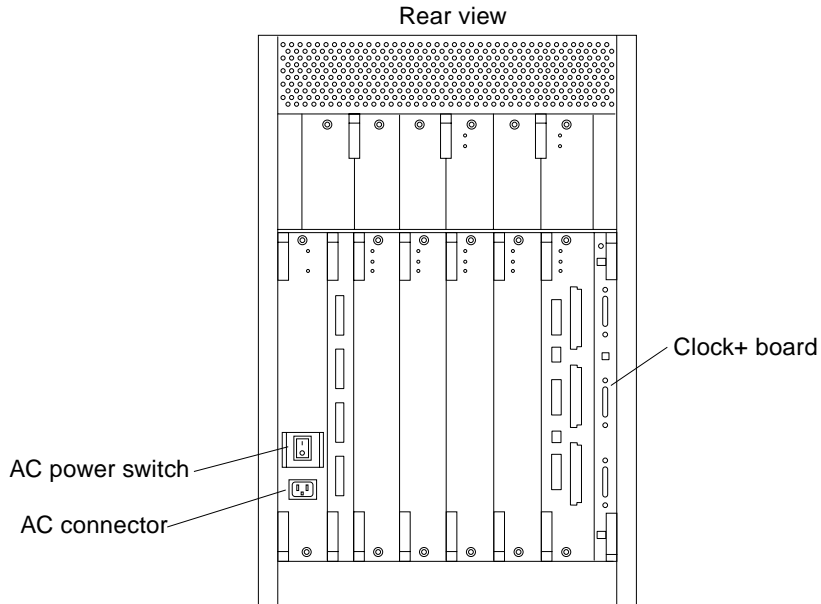

FIGURE 3-2 AC Power and Clock+ Board

6. Watch the terminal screen for error messages from the firmware diagnostic program.

POST (power-on-self-test) tests subassemblies and some interface paths between subassemblies.

At the conclusion of testing, firmware automatically attempts to reconfigure the system, omitting any parts of the system that have failed diagnostics.

If there are no faults, or if firmware completes a successful reconfiguration in response to detected faults, the system boots.

Note – If faulty parts are detected and configured out of the working system, you and the system manager must decide whether to operate the system until replacement parts arrive or to halt operation. Also, if a faulty component cannot be replaced in the field, the entire subassembly (like the system board) must be replaced.

7. To restart firmware, or if the system hangs, press the CPU reset switch on the clock+ board (FIGURE 3-3).

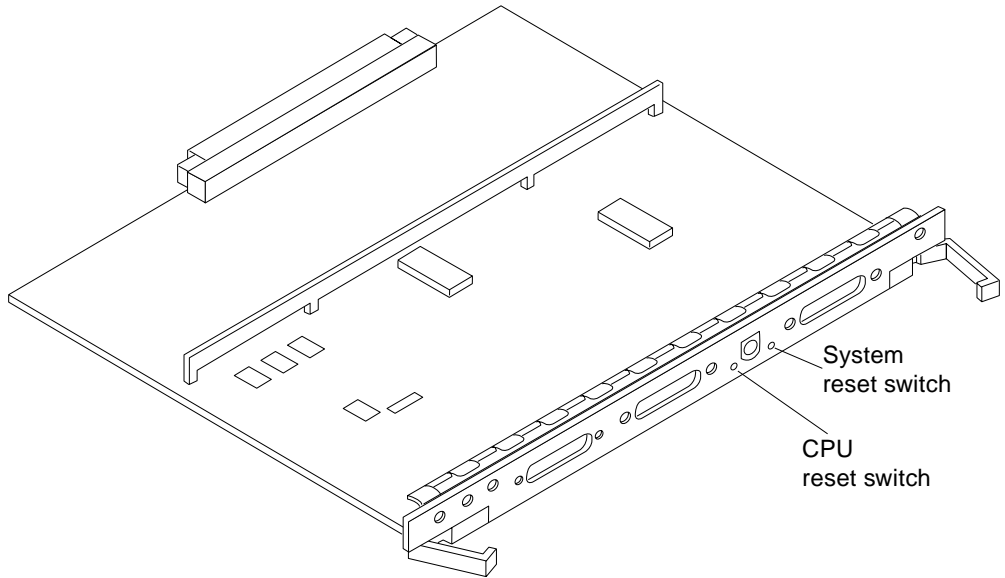

FIGURE 3-3 CPU Reset Switch on Clock+ Board

3.2.1 Reading Boot Messages

Use the boot software messages to verify that all options are installed and recognized by the system. After firmware completes the system self-test, a message similar to the following will appear on your screen. The message lists hardware detected in the system.

Note – This screen display is an example only. The actual message displayed on the screen will depend on the software running on your system.

```
5-slot Sun Enterprise 3500, Keyboard Present
OpenBoot -.- FCS, --- MB memory installed, Serial #---.
Ethernet address -:-:--:--:--:--:--:--:--, Host ID: -----.
```

If firmware indicates a hardware problem at this time, refer to the *Sun Enterprise 3500 System Reference Manual*, Part 3, “Troubleshooting,” for further instructions.

Boot the system using the procedure that is appropriate for your operating system. See the Preface “UNIX Commands,” for a reference to documentation that describes this procedure.

3.2.2 Interpreting Status LED Patterns

If there is no terminal on the system, basic system status information is available on the front panel LEDs (FIGURE 3-4).

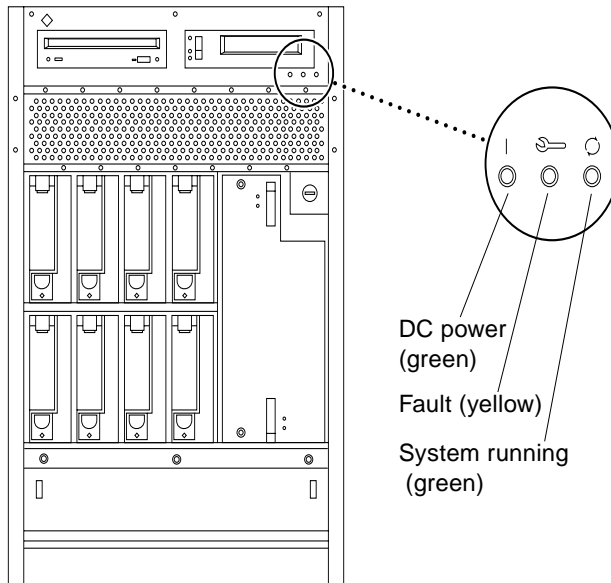

FIGURE 3-4 System Status LED

Note – The system is in OBP if the left LED is on (green), the middle LED is flashing (yellow), and the right LED is off.

After the boot process completes, check the status of the system by inspecting system status LEDs on the front panel. See FIGURE 3-4 and TABLE 3-1, which summarize LED status indications.

TABLE 3-1 Front Panel LED System Status

LED Position	Condition
Left LED (green)	On — the power supply is delivering DC power
Middle LED (yellow)	On flashing — (first 60 seconds of AC power) self tests are running Off — (after self tests end) no hardware failures detected On — (after self tests end) hardware failure was detected
Right LED (green)	Off — (first 60 seconds of AC power) self tests are running On flashing — (after self tests end) system is running Off — (after self tests end) system cannot run; repair is needed

If the left LED is on (green), the middle LED is flashing (yellow), and the right LED is off, the system is in OBP.

Ideally, when the self-test completes, both left and right LEDs are on. Less ideal is if all LEDs are on (system needs service, but is able to run). The worst condition is if the left and middle LEDs are on (system cannot boot), or if no LED is on.

3.3 Powering Off the System

Before turning off the system power, you must halt the operating system. See the Preface, “UNIX Commands,” to find references if you need help with the commands for this task or other system administration procedures.

Note – Failure to halt the operating system properly can cause the loss of disk drive data.

Note – Do not disconnect the terminal while the system is running.



Caution – To avoid damaging internal circuits, do not disconnect or connect any cable while power is applied to the system.

To shut down the system:

- 1. Notify users that the system is going down.**
- 2. Back up the system files and data to tape, if necessary.**
- 3. Halt the system using the appropriate commands.**
Refer to the *Solaris Handbook for SMCC Peripherals* that corresponds to your operating system.
- 4. Wait for the system-halted message and the boot monitor prompt.**
- 5. Use the key to unlock the system front door and pull on the handle to open the door.**
- 6. Locate the system key switch in the upper right corner, and turn the key switch to the Standby position (fully counterclockwise) (FIGURE 3-1).**
- 7. Turn off the system power in this order:**
 1. External drives and expansion cabinets (if any)
 2. System AC power switch (FIGURE 3-2)
 3. Terminal

For more system administration information on methods for shut-down and backup, see the Preface, "UNIX Commands," for references to documentation that describes these procedures.

Software

4.1 Operating System Software and Patches

Refer to the operating environment documentation that came with your system for more information on operating system software.

4.1.1 Software Patches for Solaris Operating Environment and Sun StorEdge™ Products

The following patches provide support for the Fibre Channel internal drives:

TABLE 4-1 Enterprise 3500 Patch Support for Fibre Channel Internal Drives

Operating Environment	Patches Basic Function(s)	Sun Enterprise 3500
Solaris 2.5.1 (b)	OBP and SOC+ Fcode	103346
	SSD	104708
	IB, Socal,luxadm and sf	105310
	SES	105324
Solaris 2.6	OBP and SOC+ Fcode	103346
	SSD	105356
	SES	105357
	IB, Socal,luxadm and sf	105375
	Luxadm man page	106219
Solaris 7	OBP and SOC+ Fcode	103346
	SSD	107458
	Socal and sf	107469
	SES	107472
	IB, and luxadm	107473
Solaris 8	OBP and SOC + Fcode	103346
	FC100/s Fcode (Sbus)	109400
	Socal and sf	109460
	SSD	109524

Contact your authorized Sun support provider for more patch information.

4.2 Sun™ Management Center Software

Sun™ Management Center features a graphical user interface (GUI) that shows various graphs reflecting system status.

Sun Management Center, which complement network-wide and enterprise-wide system management tools, is accessible through an SNMP interface from network tools such as Solstice SunNet Manager™.

Refer to the online *Sun Management Center User's Guide* for start up and operating instructions.

4.3 Dynamic Reconfiguration for Hot-Pluggable System Boards

If the dynamic reconfiguration feature is enabled in the operating environment, service providers can install, remove, or replace a hot-pluggable system board without powering down the system. For the Solaris 2.6, Solaris 7, and Solaris 8 Operating Environments, dynamic reconfiguration applies to specific types of boards in the Sun Enterprise 3x00. For instructions, refer to the *Sun Enterprise 6x00, 5x00, 4x00, and 3x00 Systems Dynamic Reconfiguration User's Guide* included in the online AnswerBook2 for your Solaris Operating Environment or refer to the docs.sun.com web site for more information on dynamic reconfiguration.

4.4 CPU Over-Temperature Safeguard (COS)

The CPU over-temperature safeguard (COS) software feature is automatically available on the Sun Enterprise 3500 system. COS ensures that the temperature on any CPU/Memory+ board does not go above the safe operating range.

Refer to the online *Platform Notes* for information about COS requirements and operation.

Regulatory Agency Compliance Statements

Your Sun product is marked to indicate its compliance class:

- Federal Communications Commission (FCC)—U.S.A.
- Department of Communications (DOC)—Canada
- Voluntary Control Council for Interference (VCCI)—Japan
- European Union (CE mark)—Europe
- Bureau of Standards Metrology and Inspection (BSMI) — Taiwan

Please read the appropriate section that corresponds to the marking on your Sun product before attempting to install the product.

A.1 FCC Class A Notice

This device complies with Part 15 of the FCC Rules. Operation is subject to the following two conditions:

1. This device may not cause harmful interference.
2. This device must accept any interference received, including interference that may cause undesired operation.

Note – This equipment has been tested and found to comply with the limits for a Class A digital device, pursuant to Part 15 of the FCC Rules. These limits are designed to provide reasonable protection against harmful interference when the equipment is operated in a commercial environment. This equipment generates, uses and can radiate radio frequency energy and, if not installed and used in accordance with the instruction manual, may cause harmful interference to radio communications. Operation of this equipment in a residential area is likely to cause harmful interference in which case the user will be required to correct the interference at his own expense.

Shielded Cables: Connections between the workstation and peripherals must be made using shielded cables in order to maintain compliance with FCC radio frequency emission limits. Networking connections can be made using unshielded twisted-pair (UTP) cables.

Modifications: Any modifications made to this device that are not approved by Sun Microsystems, Inc. may void the authority granted to the user by the FCC to operate this equipment.

A.2 DOC Class A Notice – Avis DOC, Classe A

This Class A digital apparatus meets all requirements of the Canadian Interference-Causing Equipment Regulations.

Cet appareil numérique de la classe A respecte toutes les exigences du Règlement sur le matériel brouilleur du Canada.

VCCI 基準について

第一種 VCCI 基準について

第一種 VCCI の表示があるワークステーションおよびオプション製品は、第一種情報装置です。これらの製品には、下記の項目が該当します。

この装置は、第一種情報装置(商工業地域において使用されるべき情報装置)で商工業地域での電波障害防止を目的とした情報処理装置等電波障害自主規制協議会(VCCI)基準に適合しております。したがって、本製品を、住宅地域または住宅地域に隣接した地域でご使用になりますと、ラジオ、テレビジョン受信機等に受信障害を与えることがあります。

取り扱い説明書に従って正しくお取り扱いください。

第二種 VCCI 基準について

第二種 VCCI の表示  があるワークステーションおよびオプション製品は、第二種情報装置です。これらの製品には、下記の項目が該当します。

この装置は、第二種情報装置(住宅地域または住宅地域に隣接した地域において使用されるべき情報装置)で住宅地域での電波障害防止を目的とした情報処理装置等電波障害自主規制協議会(VCCI)基準に適合しております。しかし、本製品を、ラジオ、テレビジョン受信機に近接してご使用になりますと、受信障害の原因となることがあります。

取り扱い説明書に従って正しくお取り扱いください。

A.3 BSMI Class A Notice

The following statement is applicable to products shipped to Taiwan and marked as Class A on the product compliance label

警告使用者：
這是甲類的資訊產品，在居住的環境中使用時，可能會造成射頻干擾，在這種情況下，使用者會被要求採取某些適當的對策。

Declaration of Conformity

Compliance ID: 401
Product Name: Sun Enterprise 3500 Family

EMC

European Union

This equipment complies with the following requirements of the EMC Directive 89/336/EEC:

EN55022:1998/CISPR22:1997		Class A
EN55024:1998	EN61000-4-2	4 kV (Direct), 8 kV (Air)
	EN61000-4-3	3 V/m
	EN61000-4-4	1.0 kV AC Power Lines, 0.5 kV Signal and DC Power Lines
	EN61000-4-5	1 kV AC Line-Line and Outdoor Signal Lines
		2 kV AC Line-Gnd, 0.5 kV DC Power Lines
	EN61000-4-6	3 V
	EN61000-4-8	1 A/m
	EN61000-4-11	Pass
EN61000-3-2:1995 w/Amendments 1, 2		Pass
EN61000-3-3:1995		Pass

Safety

This equipment complies with the following requirements of the Low Voltage Directive 73/23/EEC:

EC Type Examination Certificates:

EN60950:1992, 2nd Edition, Amendments 1, 2, 3, 4, 11	TUV Rheinland Certificate No. S 9872020
IEC 950:1991, 2nd Edition, Amendments 1, 2, 3, 4	
Evaluated to all CB Countries	CB Scheme Certificate No.UL2205-138989/USA
FDA DHHS Accession Number (Monitors Only)	

Supplementary Information

This product was tested and complies with all the requirements for the CE Mark.

/S/

Dennis P. Symanski
Manager, Compliance Engineering
Sun Microsystems, Inc.
901 San Antonio Road, MPK15-102
Palo Alto, CA 94303-4900 U.S.A
Tel: 650-786-3255
Fax: 650-786-3723

DATE

/S/

Peter Arkless
Quality Manager
Sun Microsystems Scotland, Limited
Springfield, Linlithgow
West Lothian, EH49 7LR
Scotland, United Kingdom
Tel: 0506-670000
Fax: 0506-760011

DATE

Index

A

- AC power
 - cord, connecting, 2-3
 - switch, 2-4, 3-2
- air conditioning needs, 1-4
- ASCII terminal
 - cabling and setup, 2-8
 - removal, 3-7
- automatic installation, JumpStart, 3-1

B

- bend radius, fiber optic cable, 2-1
- boot messages, 3-5

C

- cable organizer
 - wrapping, 2-13
- cabling
 - ASCII terminal, 2-8
 - Ethernet, length, 2-8
 - fiber, 2-10
 - fiber optic, installing organizer, 2-1
 - interface board, 2-12
 - network, 2-5
 - power, 2-3
 - preparing for, 2-1
 - SCSI, 2-15
 - twisted-pair, 1-4
- cautions
 - SCSI bus, SBus, 2-15

- clearance, system, 1-6
- compliance
 - regulatory agency, A-1
- conformity declaration, A-5
- connecting
 - power cord, 2-3
- cord, power, 1-3

D

- disk drives
 - FC-AL, 2-12
 - ports, 2-12
- duplicate addresses, caution, 2-15

E

- error messages
 - POST, 3-2
 - terminal, 3-2
- Ethernet
 - cable
 - length, 2-8
 - limitations, 2-7
 - preparing for, 1-4

F

- FC-AL disk drives, 2-12
- fiber cable, 2-10
 - installing organizer, 2-1

- interface board, 2-12
- routing, 2-14
- wrapping, 2-13

G

- GBICs
 - I/O+ board, 2-10
 - interface board, 2-12

H

- halting the system, 3-7

I

- installation, preparing for, 1-1
- interface board, 2-12
 - cabling, 2-12
 - ports, 2-12

J

- JumpStart installation program, 3-1

K

- keys, location, 1-3

L

- LEDs
 - status, 3-7
- lifting the server, 1-2
- limitations, cable, Ethernet, 2-7
- link test function, 1-6, 2-8

M

- messages
 - boot, 3-5
 - error, 3-2
- MII connector, 1-4

N

- naming, server, IP address, etc., 1-7
- network
 - cabling, 2-5 to 2-6
 - site preparation, 1-4
 - transceiver, 1-6

P

- ports, 2-13
- POST
 - error messages, 3-2
 - program, 2-8
 - reconfiguration of system, 3-4
- power
 - cabling, 2-3
 - cord, location, 1-3
 - off the system, 3-7
 - on the system, 3-2
- power-on self-test *See* POST
- precaution, automatic installation JumpStart, 3-1
- preparing
 - electrical circuits, 1-3
 - for cabling, 2-1
 - for installation, 1-1

R

- reconfiguration, system, POST, 3-4
- remove
 - ASCII terminal, 3-7
- reset switch
 - usage of, 3-4

S

- SBus
 - caution, 2-15
- SCSI
 - bus, caution, 2-15
 - cabling, 2-15
- shipping and storing, 1-3
- site preparation
 - air conditioning, 1-4
 - area, 1-6
 - network, 1-4

Solstice SyMON, 4-2
status LEDs, 3-7
switch
 AC, 2-4, 3-2
 reset, 3-4
system clearance, 1-6

T

test, link test, 2-8
transceiver, network, 1-6
TTY terminal, *See* ASCII terminal
twisted-pair cable, 1-4

U

unpacking, 1-2

