

For mounting locations in a system or expansion cabinet, refer to the *Rackmount Placement Matrix* (part number 802-6945-11, or later).

If there are three Ultra™ Enterprise™ 4000 chassis in a rack, you must also install the Ultra Enterprise Cabinet Air Baffle (part number X9601A).

Note – The chassis is heavy. In the following procedures, two people are required to move the chassis.

Inventory

The rack-mounting kit contains:

- Left rail
- Right rail
- Base plate
- 4 Screws, M6 x 10 mm
- 16 Screws, 10-32 x 1/2 inch

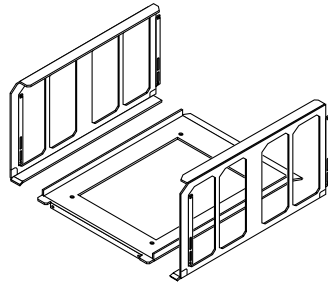

Removing the Outer Panels

1. Disconnect all cables from the Enterprise 4000 chassis.
2. Remove the upper bezel:
 - a. Press the lower left and right sides of the upper bezel to release the locking tabs.
 - b. Swing the bottom edge of the bezel toward you to release the tabs in the top of the bezel, then lift the bezel off.
3. Remove the right and left side panels:
 - a. Push the side panel back approximately 3/4 of an inch (2 cm).
 - b. Pull the bottom of the panel away from the side, then lift the panel off.
Mounting tabs are located at top of the panel.

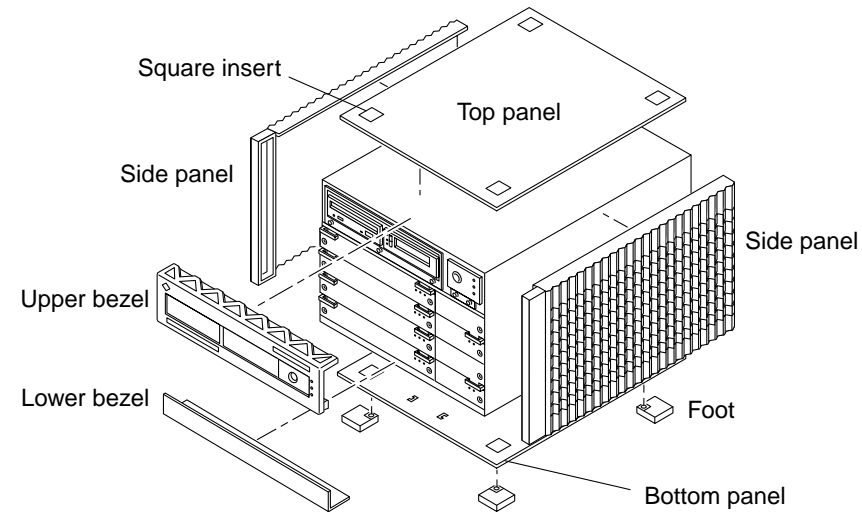

4. Remove the top panel:
 - a. Remove the square inserts from the corners of the top panel.
Press the small dot to tilt an insert up, then lift it off.
 - b. Lift the front corners of the top panel 1/8 inch (3 mm).
There are two locking tabs at the front corners of the panel.
 - c. Push the panel back 1 inch (2.5 cm), then lift it off.
5. Remove the bottom panel:
 - a. Turn the chassis upside down.
 - b. Remove the four feet by removing the screw that holds each foot.
 - c. Lift the front corners of the bottom panel, push the panel toward the back of the chassis, and lift the panel off.
6. Remove the lower bezel:
 - a. With the chassis still upside down, use a flat-bladed screwdriver to lift the left side of the lower bezel approximately 1/8 of an inch (3 mm).
 - b. Slide the bezel 1/4 of an inch (6 mm) to the left and lift it off.

Installing the Rackmount Kit

1. Place the base plate on the bottom of the chassis.
The front of the base is angled away from the chassis.
2. Use four M6x10 screws to attach the base plate to the bottom of the Ultra Enterprise 4000 chassis.

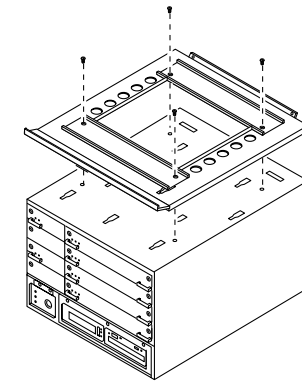

3. Attach the left rail to the rack:
 - a. Refer to the *Rackmount Placement Matrix* to determine which mounting holes you will use. The screw holes on the rack are numbered for easy identification.
 - b. Loosely fit the two top screws in the sides of the rack.
 - c. Slide the rail onto the screws.

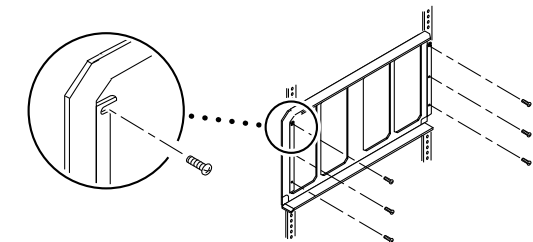

- d. Install the four remaining screws, then tighten all six screws.
4. Install the right side rail in the same manner.

Installing the Server Chassis

1. Remove the front door of the cabinet.
 - For an expansion cabinet, lift the door off the hinge pins.
 - For a server cabinet, pull off the front panel, then lift the door.
2. Lower the leveling pads to ensure that the cabinet cannot move.



Caution – The next two steps require two people.

3. Turn the Ultra Enterprise 4000 chassis right side up.
4. Slide the chassis and base plate onto the rails.

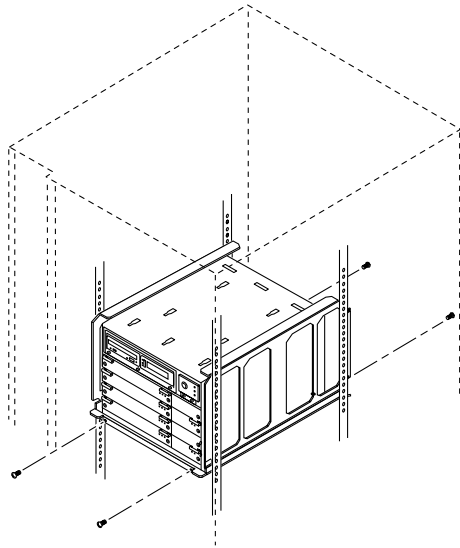

5. Secure the base plate to the side rails with four 10-32 x 1/2 inch screws, two screws at the front and two screws at the rear.
6. Connect the chassis to the power sequencer:
 - For chassis 1, disconnect the AC cable of the rack fan tray from socket J2 and connect the AC cable to J6, then connect the Enterprise 4000 chassis to socket J2.
 - For chassis 2, use socket J7.
 - For chassis 3, use socket J11.

7. Route the interface cables as appropriate and connect them to the Enterprise 4000 chassis.
8. Reattach the upper bezel (which shows the keyswitch positions). Start at the back edge, then swing the front down until the locking tabs click into place.

Note – If it is necessary to remove the bezel, the locking tabs will be easier to reach if you remove the four screws that secure the base plate to the side rails (shown in the previous drawing) and pull the chassis out approximately 1 inch (2.5 cm). Secure the base plate again afterward.

9. Replace the front door.

Ordering Sun Documents

SunDocsSM is a distribution program for technical documentation and is available from SunExpress. You can find a full listing of available documentation on the World Wide Web:

<http://www.sun.com/sunexpress/>

To order or for more information:

Telephone: 1-800-873-7869 (United States and Canada only)

Fax: 1-800-944-0661 (United States and Canada only)

Reader Comments

Your comments and suggestions are important to us. Please let us know what you think about the *Sun Enterprise 4000 Rack-Mounting Instructions*, part number 802-7249-11.

You can send detailed comments via email to smcc-docs@sun.com, or send a fax to *SMCC Doc Feedback* at (650) 786-6443.

Copyright 1997 Sun Microsystems, Inc. All rights reserved. Use is subject to license terms. Third-party software, including font technology, is copyrighted and licensed from Sun suppliers. Sun, Sun Microsystems, the Sun Logo, SunDocs, and Solaris are trademarks or registered trademarks of Sun Microsystems, Inc. in the U.S. and other countries. **RESTRICTED RIGHTS:** Use, duplication, or disclosure by the U.S. Government is subject to restrictions of FAR 52.227-14(g)(2)(6/87) and FAR 52.227-19(6/87), or DFAR 252.227-7015(b)(6/95) and DFAR 227.7202-3(a).

Copyright 1997 Sun Microsystems, Inc. Tous droits réservés. Distribué par des licences qui en restreignent l'utilisation. Le logiciel détenu par des tiers, et qui comprend la technologie relative aux polices de caractères, est protégé par un copyright et licencié par des fournisseurs de Sun. Sun, Sun Microsystems, le logo Sun, SunDocs, et Solaris sont des marques de fabrique ou des marques déposées de Sun Microsystems, Inc. aux Etats-Unit et dans d'autres pays.

 Sun Microsystems Computer Company • 901 San Antonio Road • Palo Alto, CA 94303-4900
USA • 650-960-1300 • Fax 650 969-9131



Part Number: 802-7249-11
Revision A of December 1997



Sun™ Enterprise™ 4000 Rackmounting Guide

