

To install the CPU module you need:

- #1 Phillips screwdriver
- Padded ESD mat
- Grounding wrist strap
- Torque screwdriver, set to 6 inch-pounds

Hot-Plug Feature



Caution – If the message: NOTICE: Hot Plug not supported in this system is displayed during boot, do NOT attempt to remove or install a board while the system is powered on.

If you install a hot-pluggable board in a running system, you must reboot to add the board to the system configuration.



Caution – Do not hot-plug an Enterprise system component if the peripheral power supply (PPS), in the 6x00/5x00/4x00 system, or the peripheral power supply/AC input (PPS/AC), in the 3x00 system, is inoperative. These power supplies provide the precharge voltage required for hot-plug. Use `prtdiag(1M)` to determine the peripheral power supply status.

Precautions

- Use a grounding wrist strap for these procedures.
- Hold the CPU module only by the edges to prevent heatsink breakage.
- Do not touch the connector pins, to prevent corrosion.
- Use a padded ESD mat for the CPU/Memory board. The padding prevents breakage of parts on the bottom of the board.

Removing the CPU/Memory Board

1. **Ensure that the board is in low-power mode and ready for removal.**
If the board is not in low-power mode, halt the system and turn off the power before proceeding. The board is in low-power mode if one of the following is true:
 - The three LEDs on the board are not lit (board has no power).
 - The outer two green LEDs are not lit and the middle yellow LED is lit.



Caution – Use a grounding wrist strap to prevent static damage.

2. **With a #1 Phillips screwdriver, turn the two quarter-turn access slots to the unlocked position (■).**

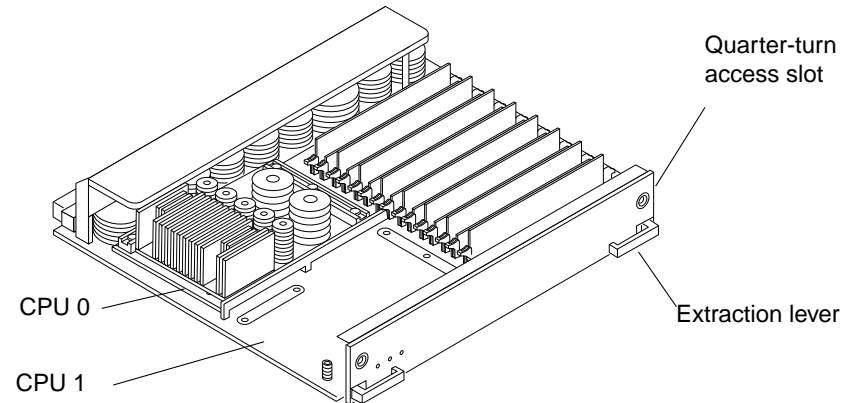

3. **Simultaneously pull the ends of both extraction levers toward you to disconnect the board from the centerplane.**
Pull both levers simultaneously to avoid twisting the board and bending the connector pins.
4. **Pull the board out of the card cage.**
Do not let the components on the board catch on any surrounding surfaces as you pull the board.



Caution – The heatsinks on the board may be hot. Handle with care.

5. **Place the board on a padded ESD mat.**
The padding protects components on the bottom of the board.

Suggestions for Maximum Performance

1. Fill all the CPU 0 slots before using any CPU 1 slots.
2. Start with the CPU/Memory board in the lowest numbered slot.
3. After all CPU 0 slots are filled, use CPU 1 slots, again starting with the CPU/Memory board in the lowest numbered slot.

CPU Module Installation Procedure



Caution – Use a grounding wrist strap to prevent static damage.

1. **On the board and the module, inspect the connectors for dust.**
If necessary, clean the connectors with a dry, stiff toothbrush.
2. **Holding the module by the edges, align it over the board connectors.**
3. **Firmly but gently press the module straight down until the standoff post snaps into place and the connectors are fully seated.**
4. **Tighten the hex screws of the module as follows:**
 - a. **Use the torque screwdriver to *partially tighten* the five 3/32 hex screws in the tightening sequence shown.**
IMPORTANT: *Partially tighten* the screws in order until they just touch the compression connectors, beginning with screw 1.

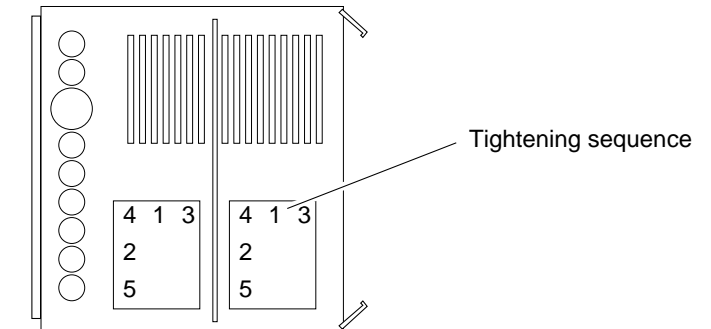

- b. **Use the torque screwdriver to tighten the five screws an additional half-turn in the tightening sequence shown.**
- c. **Finish the module installation by tightening all the screws to 6 inch-pounds in the same tightening sequence.**



Caution – Do not over-torque or under-torque the screws. Excessive force can warp the connector. Insufficient force can cause an incomplete electrical connection.

Installing the CPU/Memory Board

1. If you are installing a new board, refer to the Enterprise server system manual for rules for selecting a board slot.



Caution – Use a grounding wrist strap to prevent static damage.

2. Open the extraction levers by pulling the ends of both levers toward you.
 - For a front slot in a 16-slot or 8-slot card cage, orient the board with the component-side down.
 - For a rear slot in a 16-slot or 8-slot card cage, orient the board component-side up.

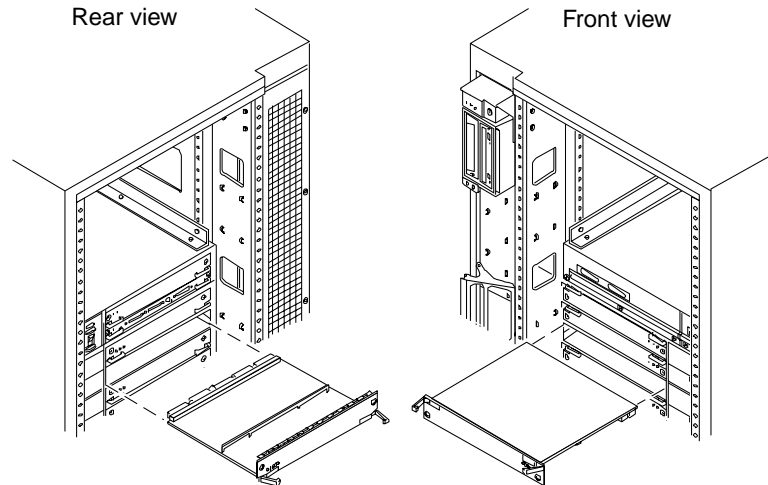

- For a 4- or 5-slot card cage with vertical slots, orient the board with the component side to the right.
3. Insert the board into the card cage, then simultaneously press both extraction levers to seat the board on the centerplane.



Caution – When inserting a board into slot 4 or slot 10 of a 16-slot card cage, lift the board slightly to avoid damage to the centerplane connectors.

4. With a #1 Phillips screwdriver, turn the two quarter-turn access slots to the locked position (🔒).
5. If the system is running, look for a system message similar to the following example for a CPU/Memory board in slot 5:

```
NOTICE: CPU Board Hotplugged into Slot 5
NOTICE: Board 5 is ready to remove
```

6. Reboot the system or schedule a later time to reboot when system disruption will be minimized.
The system does not recognize the new board until the system is rebooted.

Sun Documentation on the Web

The docs.sun.com web site enables you to access Sun technical documentation on the Web. You can browse the docs.sun.com archive or search for a specific book title or subject at:

<http://docs.sun.com>

Sun Welcomes Your Comments

We are interested in improving our documentation and welcome your comments and suggestions. You can email your comments to us at:

smcc-docs@sun.com

Please include the part number of your document in the subject line of your email.

Copyright 1998 Sun Microsystems, Inc. All rights reserved. Use is subject to license terms. Third-party software, including font technology, is copyrighted and licensed from Sun suppliers. Sun, Sun Microsystems, the Sun Logo, SunDocs, and Solaris are trademarks or registered trademarks of Sun Microsystems, Inc. in the U.S. and other countries. **RESTRICTED RIGHTS:** Use, duplication, or disclosure by the U.S. Government is subject to restrictions of FAR 52.227-14(g)(2)(6/87) and FAR 52.227-19(6/87), or DFAR 252.227-7015(b)(6/95) and DFAR 227.7202-3(a).

Copyright 1998 Sun Microsystems, Inc. Tous droits réservés. Distribué par des licences qui en restreignent l'utilisation. Le logiciel détenu par des tiers, et qui comprend la technologie relative aux polices de caractères, est protégé par un copyright et licencié par des fournisseurs de Sun. Sun, Sun Microsystems, le logo Sun, SunDocs, et Solaris sont des marques de fabrique ou des marques déposées de Sun Microsystems, Inc. aux Etats-Unit et dans d'autres pay.

Sun Microsystems Computer Company • 901 San Antonio Road • Palo Alto, CA 94303-4900
USA • 650 960-1300 • Fax 650 969-9131 

Part Number: 802-5031-13
Revision A of April 1998



Sun™ Enterprise™ 6x00/5x00/4x00/3x00 Systems CPU Module Installation Guide



Caution – The heatsinks on the board can be damaged by incorrect handling. Do not touch the heatsinks while installing or moving the board. Hold the board only by the edges. If a heatsink is loose or broken, obtain a replacement board.



Caution – The heatsinks on the board can be damaged by improper packaging. When storing or shipping the board, ensure that the heatsinks have sufficient protection.

Requirements

- 250 MHz UltraSPARC™ modules must not be mixed with different speed UltraSPARC modules.
- If this is the first 250 MHz UltraSPARC module in your xx00 system, you require the clock board upgrade package (part number: UG-ENT-CLOCKBD). This upgrade package includes a clock board (501-4286), the CD, Flash PROM Update 1.4, and instructions.
- When a 250 MHz UltraSPARC module is installed in a system running the Solaris™ 2.5.1 operating environment, you must install the software patch #103640 (version -06 or higher).



To install the CPU module you need:

- #1 Phillips screwdriver
- Padded ESD mat
- Grounding wrist strap
- Torque screwdriver, set to 6 inch-pounds

Hot-Plug Feature



Caution – If the message: NOTICE: Hot Plug not supported in this system is displayed during boot, do NOT attempt to remove or install a board while the system is powered on.

If you install a hot-pluggable board in a running system, you must reboot to add the board to the system configuration.



Caution – Do not hot-plug an Enterprise system component if the peripheral power supply (PPS), in the 6x00/5x00/4x00 system, or the peripheral power supply/AC input (PPS/AC), in the 3x00 system, is inoperative. These power supplies provide the precharge voltage required for hot-plug. Use `prtdiag(1M)` to determine the peripheral power supply status.

Precautions

- Use a grounding wrist strap for these procedures.
- Hold the CPU module only by the edges to prevent heatsink breakage.
- Do not touch the connector pins, to prevent corrosion.
- Use a padded ESD mat for the CPU/Memory board. The padding prevents breakage of parts on the bottom of the board.

Removing the CPU/Memory Board

1. **Ensure that the board is in low-power mode and ready for removal.**
If the board is not in low-power mode, halt the system and turn off the power before proceeding. The board is in low-power mode if one of the following is true:
 - The three LEDs on the board are not lit (board has no power).
 - The outer two green LEDs are not lit and the middle yellow LED is lit.



Caution – Use a grounding wrist strap to prevent static damage.

2. **With a #1 Phillips screwdriver, turn the two quarter-turn access slots to the unlocked position (■).**

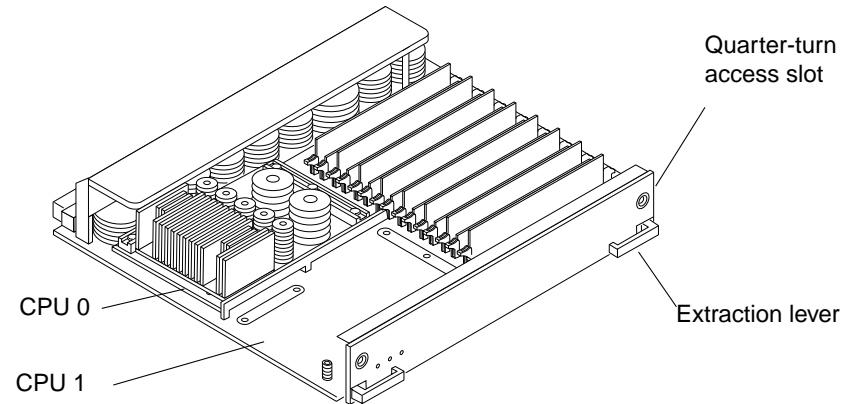

3. **Simultaneously pull the ends of both extraction levers toward you to disconnect the board from the centerplane.**
Pull both levers simultaneously to avoid twisting the board and bending the connector pins.
4. **Pull the board out of the card cage.**
Do not let the components on the board catch on any surrounding surfaces as you pull the board.



Caution – The heatsinks on the board may be hot. Handle with care.

5. **Place the board on a padded ESD mat.**
The padding protects components on the bottom of the board.

Suggestions for Maximum Performance

1. Fill all the CPU 0 slots before using any CPU 1 slots.
2. Start with the CPU/Memory board in the lowest numbered slot.
3. After all CPU 0 slots are filled, use CPU 1 slots, again starting with the CPU/Memory board in the lowest numbered slot.

CPU Module Installation Procedure



Caution – Use a grounding wrist strap to prevent static damage.

1. **On the board and the module, inspect the connectors for dust.**
If necessary, clean the connectors with a dry, stiff toothbrush.
2. **Holding the module by the edges, align it over the board connectors.**
3. **Firmly but gently press the module straight down until the standoff post snaps into place and the connectors are fully seated.**
4. **Tighten the hex screws of the module as follows:**
 - a. **Use the torque screwdriver to *partially tighten* the five 3/32 hex screws in the tightening sequence shown.**
IMPORTANT: *Partially tighten* the screws in order until they just touch the compression connectors, beginning with screw 1.

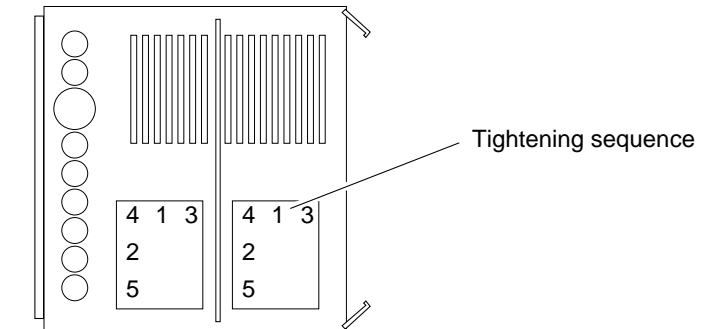

- b. **Use the torque screwdriver to tighten the five screws an additional half-turn in the tightening sequence shown.**
- c. **Finish the module installation by tightening all the screws to 6 inch-pounds in the same tightening sequence.**



Caution – Do not over-torque or under-torque the screws. Excessive force can warp the connector. Insufficient force can cause an incomplete electrical connection.

Installing the CPU/Memory Board

1. If you are installing a new board, refer to the Enterprise server system manual for rules for selecting a board slot.



Caution – Use a grounding wrist strap to prevent static damage.

2. Open the extraction levers by pulling the ends of both levers toward you.
 - For a front slot in a 16-slot or 8-slot card cage, orient the board with the component-side down.
 - For a rear slot in a 16-slot or 8-slot card cage, orient the board component-side up.

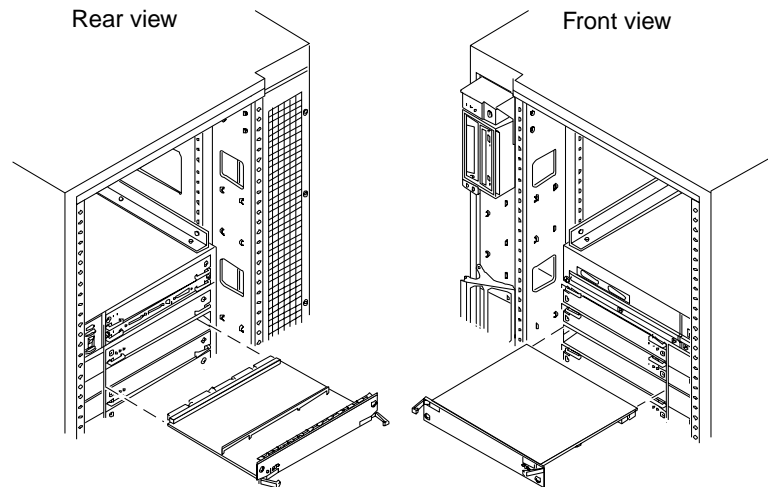

- For a 4- or 5-slot card cage with vertical slots, orient the board with the component side to the right.
3. Insert the board into the card cage, then simultaneously press both extraction levers to seat the board on the centerplane.



Caution – When inserting a board into slot 4 or slot 10 of a 16-slot card cage, lift the board slightly to avoid damage to the centerplane connectors.

4. With a #1 Phillips screwdriver, turn the two quarter-turn access slots to the locked position (🔒).
5. If the system is running, look for a system message similar to the following example for a CPU/Memory board in slot 5:

```
NOTICE: CPU Board Hotplugged into Slot 5
NOTICE: Board 5 is ready to remove
```

6. Reboot the system or schedule a later time to reboot when system disruption will be minimized.
The system does not recognize the new board until the system is rebooted.

Sun Documentation on the Web

The docs.sun.com web site enables you to access Sun technical documentation on the Web. You can browse the docs.sun.com archive or search for a specific book title or subject at:

<http://docs.sun.com>

Sun Welcomes Your Comments

We are interested in improving our documentation and welcome your comments and suggestions. You can email your comments to us at:

smcc-docs@sun.com

Please include the part number of your document in the subject line of your email.

Copyright 1998 Sun Microsystems, Inc. All rights reserved. Use is subject to license terms. Third-party software, including font technology, is copyrighted and licensed from Sun suppliers. Sun, Sun Microsystems, the Sun Logo, SunDocs, and Solaris are trademarks or registered trademarks of Sun Microsystems, Inc. in the U.S. and other countries. **RESTRICTED RIGHTS:** Use, duplication, or disclosure by the U.S. Government is subject to restrictions of FAR 52.227-14(g)(2)(6/87) and FAR 52.227-19(6/87), or DFAR 252.227-7015(b)(6/95) and DFAR 227.7202-3(a).

Copyright 1998 Sun Microsystems, Inc. Tous droits réservés. Distribué par des licences qui en restreignent l'utilisation. Le logiciel détenu par des tiers, et qui comprend la technologie relative aux polices de caractères, est protégé par un copyright et licencié par des fournisseurs de Sun. Sun, Sun Microsystems, le logo Sun, SunDocs, et Solaris sont des marques de fabrique ou des marques déposées de Sun Microsystems, Inc. aux Etats-Unit et dans d'autres pay.

Sun Microsystems Computer Company • 901 San Antonio Road • Palo Alto, CA 94303-4900
USA • 650 960-1300 • Fax 650 969-9131



Part Number: 802-5031-13
Revision A of April 1998



Sun™ Enterprise™ 6x00/5x00/4x00/3x00 Systems CPU Module Installation Guide



Caution – The heatsinks on the board can be damaged by incorrect handling. Do not touch the heatsinks while installing or moving the board. Hold the board only by the edges. If a heatsink is loose or broken, obtain a replacement board.



Caution – The heatsinks on the board can be damaged by improper packaging. When storing or shipping the board, ensure that the heatsinks have sufficient protection.

Requirements

- 250 MHz UltraSPARC™ modules must not be mixed with different speed UltraSPARC modules.
- If this is the first 250 MHz UltraSPARC module in your xx00 system, you require the clock board upgrade package (part number: UG-ENT-CLOCKBD). This upgrade package includes a clock board (501-4286), the CD, Flash PROM Update 1.4, and instructions.
- When a 250 MHz UltraSPARC module is installed in a system running the Solaris™ 2.5.1 operating environment, you must install the software patch #103640 (version -06 or higher).

