Preparation

To install a board you will need:

- Phillips #1 screwdriver
- Grounding wrist strap

A padded ESD mat is also required if you perform any work on the board. The padding prevents breakage of parts on the bottom of the board.

Hot-Plug Feature

The hot-plug feature enables you to insert a new board into a powered-up system.



Caution – If the message: NOTICE: Hot Plug not supported in this system is displayed during boot, do NOT attempt to remove or install a board while the system is powered up.



Caution – Do not hot-plug a system component if the peripheral power supply (PPS) is inoperative. The PPS provides the precharge voltages required for hot-plug. Use `prtdiag(1M)` to determine the status of the peripheral power supply.

Ultra™ Enterprise™ servers have an Automatic System Reconfiguration (ASR) feature that reboots the system in a configuration that omits failed components (such as CPUs, memory, or I/O bus). When the system reboots, the board containing the failed components is placed in low power mode and is no longer accessible.

If a working board is added to a powered-up system with the hot-plug feature, the system will not use the new board until the system is rebooted.

Removing a Board

Start here if you are replacing a board that is already in the system.

If your system supports the hot-plug feature, a board is in low power mode and ready for removal if one of the following is true for the board status LEDs:

- All three status LEDs are off.
- The Service (🔧) LED is lit, and the Power (⊙) LED and the Running (⦿) LED are off.

1. **If the board is in low power mode, skip this step and go to Step 2.** If the board is not in low power mode, halt the system and turn off power before proceeding.

2. **With a Phillips #1 screwdriver, turn the two quarter-turn access slots to the unlocked position (🔓).**

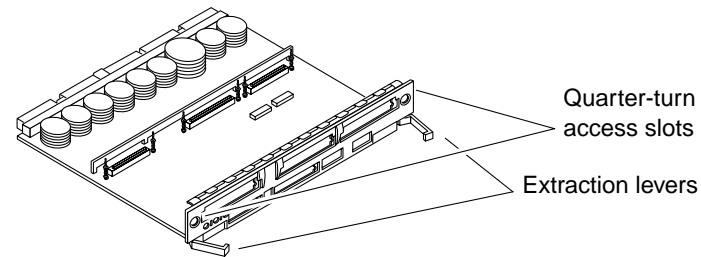

3. **Pull the ends of both extraction levers toward you, then pull the board out of the card cage.**

Do not let the components on the board catch on any surrounding surfaces as you pull the board.



Warning – The heatsinks on the board may be hot. Handle with care.

4. **Place the board on a padded ESD mat for service, or store the board in an antistatic bag.**

Installing a Board

1. **If you are installing a new board, refer to the Enterprise server system manual for rules for selecting a board slot.**

2. **Open the extraction levers by pulling the ends of both levers toward you.**

3. **Insert the board partway into the card cage slot.**

- For a front slot in a 16-slot or 8-slot card cage, orient the board with the component side down. (See below.)

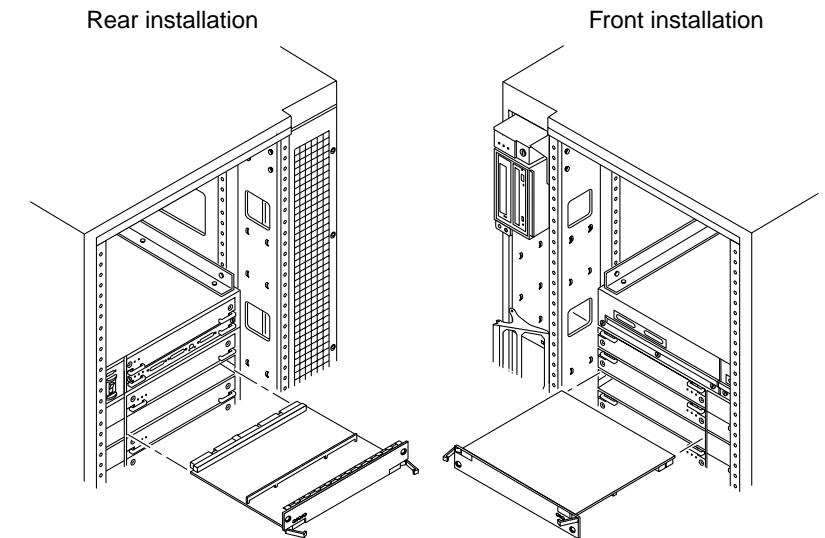

- For a rear slot in a 16-slot or 8-slot card cage, orient the board component side up. (See above.)
- For a 4-slot card cage with vertical slots, orient the board with the component side to the right.

-
4. Push the board into the card cage, then simultaneously press both extraction levers to seat the board on the centerplane.



Caution – When inserting a board into slot 4 or slot 10 of a 16-slot card cage, lift the board slightly to avoid damage to the centerplane connectors.



Caution – Do not press on the board front panel to seat it—doing so will damage the connector pins.

Pushing both levers simultaneously avoids twisting the board and bending the connector pins.

5. With a Phillips #1 screwdriver, turn the two quarter-turn access slots to the locked position (🔒).
6. If the system is running, look for a system message similar to the following example.
This example is for a CPU/Memory board in slot 5:

NOTICE: CPU Board Hotplugged into Slot 5
NOTICE: Board 5 is ready to remove

7. Reboot the system now or schedule a later time to reboot when system disruption will be minimized.
The system does not use the new board until the system is rebooted.

Ordering Sun Documents

SunDocsSM is a distribution program for technical documentation and is available from SunExpressTM. You can find a full listing of available documentation on the World Wide Web:

<http://www.sun.com/sunexpress/>

To order or for more information:

Telephone: 1-800-873-7869 (North America only)

Fax: 1-800-944-0661 (North America only)

Reader Comments

Your comments and suggestions are important to us. Please let us know what you think about the *Ultra Enterprise Board Installation Guide*, part number 802-5030-11.

You can send detailed comments via email to smcc-docs@sun.com, or send a fax to *SMCC Doc Feedback* at (415) 786-6443.

© 1996 Sun Microsystems, Inc., 2550 Garcia Avenue, Mountain View, California 94043-1100 U.S.A. All rights reserved. Sun, the Sun logo, Sun Microsystems, and Solaris are trademarks or registered trademarks of Sun Microsystems, Inc. in the United States and other countries. All SPARC trademarks, including the SCD Compliant logo, are trademarks or registered trademarks of SPARC International, Inc. in the United States and other countries. SPARCstation is licensed exclusively to Sun Microsystems, Inc. Products bearing SPARC trademark are based upon an architecture developed by Sun Microsystems, Inc.

© 1996 Sun Microsystems, Inc., 2550 Garcia Avenue, Mountain View, Californie 94043-1100 U.S.A. Tous droits réservés. Sun, le logo Sun, Sun Microsystems, et Solaris sont des marques déposées ou enregistrées par Sun Microsystems, Inc. aux Etats-Unis et dans certains d'autres pays. Toutes les marques SPARC, y compris le logo SCD Compliant, sont des marques déposées ou enregistrées de SPARC International, Inc. aux Etats-Unis et dans d'autres pays. SPARCstation est exclusivement licenciée à Sun Microsystems, Inc. Les produits portant la marque SPARC sont basés sur une architecture développée par Sun Microsystems, Inc.



Recycled Paper



Part Number: 802-5030-11
Revision A of October 1996



UltraTM EnterpriseTM X000 Systems Board Installation Guide

*CPU/Memory Board
SBUS I/O Board
Graphics I/O Board*



Caution – The heatsinks on the board can be damaged by incorrect handling. Do not touch the heatsinks while installing or moving the board. Hold the board only by the edges. If a heatsink is loose or broken, obtain a replacement board.



Caution – The heatsinks on the board can be damaged by improper packaging. When storing or shipping the board, ensure that the heatsinks have sufficient protection.

